



CX35-P800 Transmission with Optional Integral Pump Drives

Petroleum

SPECIFICATIONS

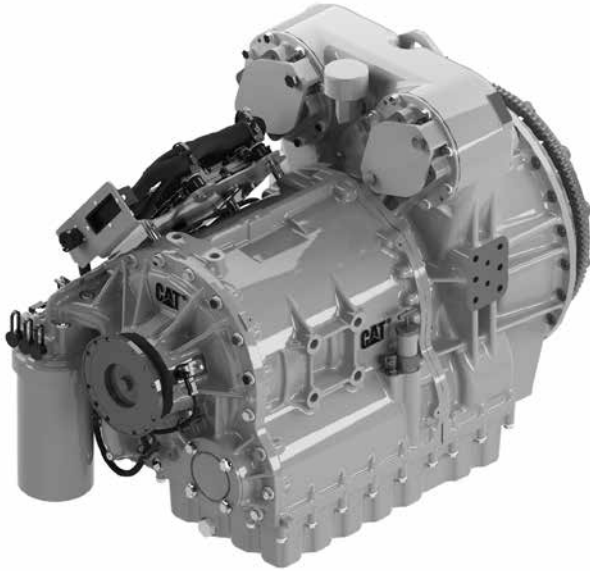

Image shown may not reflect actual transmission

Gross Input Power	800 bhp (597 bkW)
Gross Peak Input Torque	
Gears 1F-3F	2400 lb-ft (3254 N•m)
Gears 4F-8F	2700 lb-ft (3661 N•m)
Maximum Turbine Torque	
Gears 1F-3F	2400 lb-ft (3254 N•m)
Gears 4F-8F	2700 lb-ft (3661 N•m)
Rated Input Speed	2100 rpm
Maximum Input Speed	2500 rpm
Minimum Input Speed	600 rpm
Electrical System	12V or 24V
Gears	
Type	Planetary Spur
Forward/Reverse	8F/1R
Transmission Speed Ratios	
Gear	Ratio
1st	5.73
2nd	3.57
3rd	2.72
4th	1.95
5th	1.43
6th	1.00
7th	0.74
8th	0.63
1R	-4.46
Overall	9.10

FEATURES

- CX35-P800 is the most advanced Cat® well service transmission and is designed specifically to meet the demands of this market.
- Lightweight with superior power-to-weight ratio
- Diagnostics via Cat Electronic Technician
- Integral pump drives available
 - Allows for two SAE B pads and two SAE C pads to direct mount on transmission
 - Additional option for rear PTO
- Advanced software specifically designed for the well service market

BENEFITS

- Integral options streamline service:
 - Same warranty for integral pump drives and rear PTO
 - One source supplier — one source service
- Rear PTO option increases application flexibility
- With more than 40 new well service software features, CX35-P800 is the most advanced transmission available. Features include multiple modes of operation:
 - Auto pumper
 - Manual pumper
 - Workover/drawworks
- Unmatched product support offered through worldwide Cat dealer network
 - More than 2,200 dealer outlets
 - Caterpillar factory-trained dealer technicians service every aspect of your petroleum engine-transmission package
 - Caterpillar parts and labor warranty
 - Preventive maintenance agreements available for repair-before-failure options
- Web site — for all your petroleum power requirements, visit www.catoilandgasinfo.com.



CAT® ENGINE FOR OPTIMIZED POWERTRAIN

C15 ACERT™, C18 ACERT, C27 ACERT
(A ratings)

Note: See Petroleum Transmissions Approved Applications Guide REHS4553 for more information.

TRANSMISSION ROTATION

Input rotation — counterclockwise
Output rotation — counterclockwise
(as viewed from rear)

TORQUE CONVERTER

Lock-up clutch, torque converter drive and direct drive in all gears
Integral to transmission
Stall torque ratio — 1.962

CLUTCHES

Clutches — electro-hydraulic fully modulated, oil cooled, multidisc
Clutch modulation control — Cat Electronic Clutch Pressure Control (ECPC)

INSTALLATION CONNECTIONS

2 oil cooler lines
1 electrical connector

OIL SYSTEM

Cat Transmission/Drive Train Oil-4 (TDTO)
Sump oil temperatures
Continuous — 194°F (90°C)
Maximum Intermittent — 210°F (99°C)
Maximum converter outlet oil temperature — 250°F (121°C)
Hydraulic fill capacity — 9 gal (34 L), 16 gal (61L) initial fill
Filter type
Direct mount — standard
Remote mount — optional

MOUNTINGS

Input connection (flywheel) — direct SAE #1 dry flywheel housing
Side supports — two SAE #2 pads
Output connection — 1810 yoke, 1810 companion flange, SPL 250 yoke, ISO8667-T180 flange
Remote-mount ECU option
Remote-mount filter option

POWER TAKE-OFF (Pump Auxiliary Drive)

	PTO Drives (Basic)	Integral PTOs (Optional)	Rear PTO (Optional)
Location	1 o'clock and 8 o'clock; as viewed from rear	1 o'clock and 11 o'clock; as viewed from rear	5 o'clock as viewed from rear
Mounting Type	10 bolt	Front: 2 SAE B Rear: 2 SAE C	8 bolt*
Rated Torque	Single: 700 lb-ft (950 N•m) Total: 1200 lb-ft (1630 N•m)	Single: 500 lb-ft (678 N•m) Total: 688 lb-ft (933 N•m)	1000 lb-ft (1360 N•m)
Rotation	Same as engine	Same as engine as viewed from rear	Opposite of engine
Ratio	1:1	1:1	1.25:1

*SAE pump adapters and drive flanges available from third party suppliers.

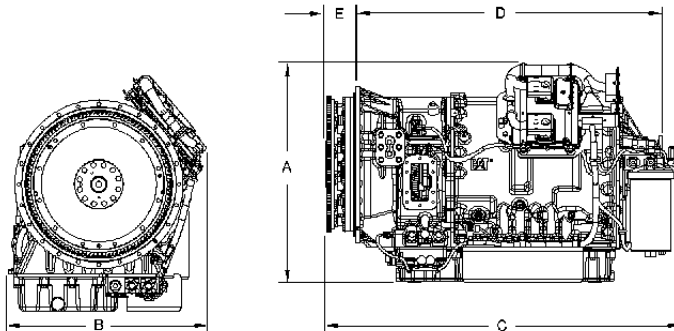
DIMENSIONS
Basic Configuration

Weight (approx.)	1435 lbs (650 kg)
Overall Height (A)	30.7 in (780 mm)
Overall Width (B)	25.8 in (654 mm)
Overall Length (C)	49.8 in (1265 mm)
Length of Drive Train (D)*	43 in (1092 mm)

*The length that is shown is with a standard 1810 companion flange.

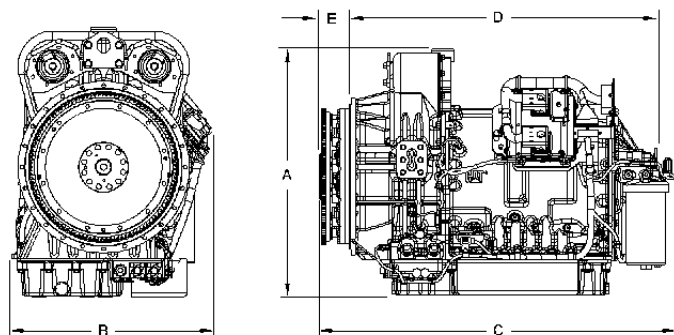
Transmission with Integral Pump Drives

Weight (approx.)	1612 lbs (731 kg)
Overall Height (A)	34.4 in (872 mm)
Overall Width (B)	25.8 in (654 mm)
Overall Length (C)	49.8 in (1265 mm)
Length of Drive Train (D)*	43 in (1092 mm)

*The length that is shown is with a standard 1810 companion flange.

**CX35-P800
Standard Configuration**

**CX35-P800
with Integral Pump Drives**

Information contained in this publication may be considered confidential. Discretion is recommended when distributing. Materials and specifications are subject to change without notice. The International System of Units (SI) is used in this publication. CAT, CATERPILLAR, their respective logos, ACERT, "Caterpillar Yellow" and the "Power Edge" trade dress, as well as corporate and product identity used herein, are trademarks of Caterpillar and may not be used without permission.