

R1700 XE

BATTERY ELECTRIC
UNDERGROUND LOADER



Rated Payload:	15 000 kg / 33,069 lb
Rated Power – peak:	250 kW / 335 hp
Rated Power – nominal:	220 kW / 295 hp
Operating Weight:	48 743 kg / 107,460 lb

CAT[®]

**UNDERGROUND
CHALLENGES.**

**INNOVATIVE
SOLUTIONS.**

Underground hard rock mining presents special challenges when it comes to safe, efficient, productive operation — from environmental concerns and rising costs to communications and connectivity challenges. Even simple logistical issues become harder to manage as you dig deeper underground in search of new reserves.

But you want to do more than address these challenges. You want to work harder and turn those challenges into opportunities to improve.



At Caterpillar, we feel the same way. We're committed to listening to your challenges and collaborating with you to find new ways to improve the way you mine. From increasing productivity and reducing emissions to lowering operating costs and reducing maintenance and more, Cat hard rock underground trucks and loaders are designed to help you meet your challenges head-on.

But we never stop looking for new ways to innovate and optimize. We continually improve our products and seek out new ways of mining, new ways to reduce impact, and new ways to get more out of game-changers like technology and automation.

No matter what you mine—or how far underground you mine it—you need an equipment provider that understands the unique problems you face, and that has years of experience in solving them. You need a partner like Caterpillar.



THE NEW CAT[®] R1700 XE

BATTERY ELECTRIC
UNDERGROUND LOADER



SUPERIOR PRODUCTIVITY. ZERO EMISSIONS.

What if you could have the class-leading payload and superior productivity of the proven Cat[®] R1700 underground loader without the engine heat or exhaust emissions? You can.

Introducing the R1700 XE battery electric LHD — a high-productivity, zero-emission loader with the industry's only onboard battery. It charges quickly — in less than 20 minutes when paired with two of the durable and mobile Cat MEC500 chargers. This provides an alternative to expensive static charging station infrastructure, as well as the need for additional batteries, battery handling and battery swapping. The machine also features Auto Dig for optimized loading and is factory-ready for autonomous operation. And it delivers the powerful performance, maximum uptime and low operating costs you demand.

ZERO EMISSIONS

- » 100% battery electric propulsion
- » Less heat generation
- » Leverages over 400 Caterpillar electrification patents

DELIVERS FULL CHARGE IN LESS THAN 20 MINUTES

- » Using dual MEC500 Mobile Equipment Chargers

ON-BOARD FAST CHARGING

- » Batteries stay on the machine maximizing available run time
- » Electrical safety built into every level of the battery system with redundant safety features

PRODUCTION PRIORITY

- » 15-tonne payload
- » Performance matching R1700
- » Auto Dig Function optimizes loading
- » Traction control maximizes tire life
- » Liquid cooling enables batteries to be cooled while the machine goes back to operation, increasing machine availability and uptime

FACTORY-READY FOR CAT® MINESTAR™ SOLUTIONS

- » Multiple levels of autonomy
- » Up to 40% increase in machine utilization with Command for underground





LOAD MORE EVERY CYCLE

THE R1700 XE ELECTRIC LOADER MATCHES THE PERFORMANCE OF THE R1700

The R1700 XE LHD delivers superior productivity in underground applications with the benefits of no engine heat or exhaust emissions. With each cycle, the R1700 XE hauls more payload while it loads, climbs, hauls and dumps faster.

65%
— MORE —
LIFT FORCE

BETTER DIGGING

The R1700 XE delivers noticeable power and performance inside the pile. The state-of-the-art hydraulic system delivers 65% more lift force than previous versions and 24,190-kg lift and tilt breakout. The front linkage cylinders have been repositioned for better mechanical lift. Autodig helps new operators be productive faster and reduces fatigue for all operators.

FAST, POWERFUL LOADING

Fast dumping times — 13.2 seconds to raise, dump and lower — combined with an 18-kph (11 mph) top speed and new traction control system result in reduced cycle times, more material moved and lower cost per tonne. Excellent machine balance and a new electrohydraulic braking system aid load-and-carry cycles.

BIGGER PAYLOAD

Thanks to a 20% capacity increase from previous models, the R1700 XE is a true 15-tonne (16.5-ton) loader for both load and haul and truck loading applications.

20%
CAPACITY
INCREASE

Improvements shown are compared to the R1700G.

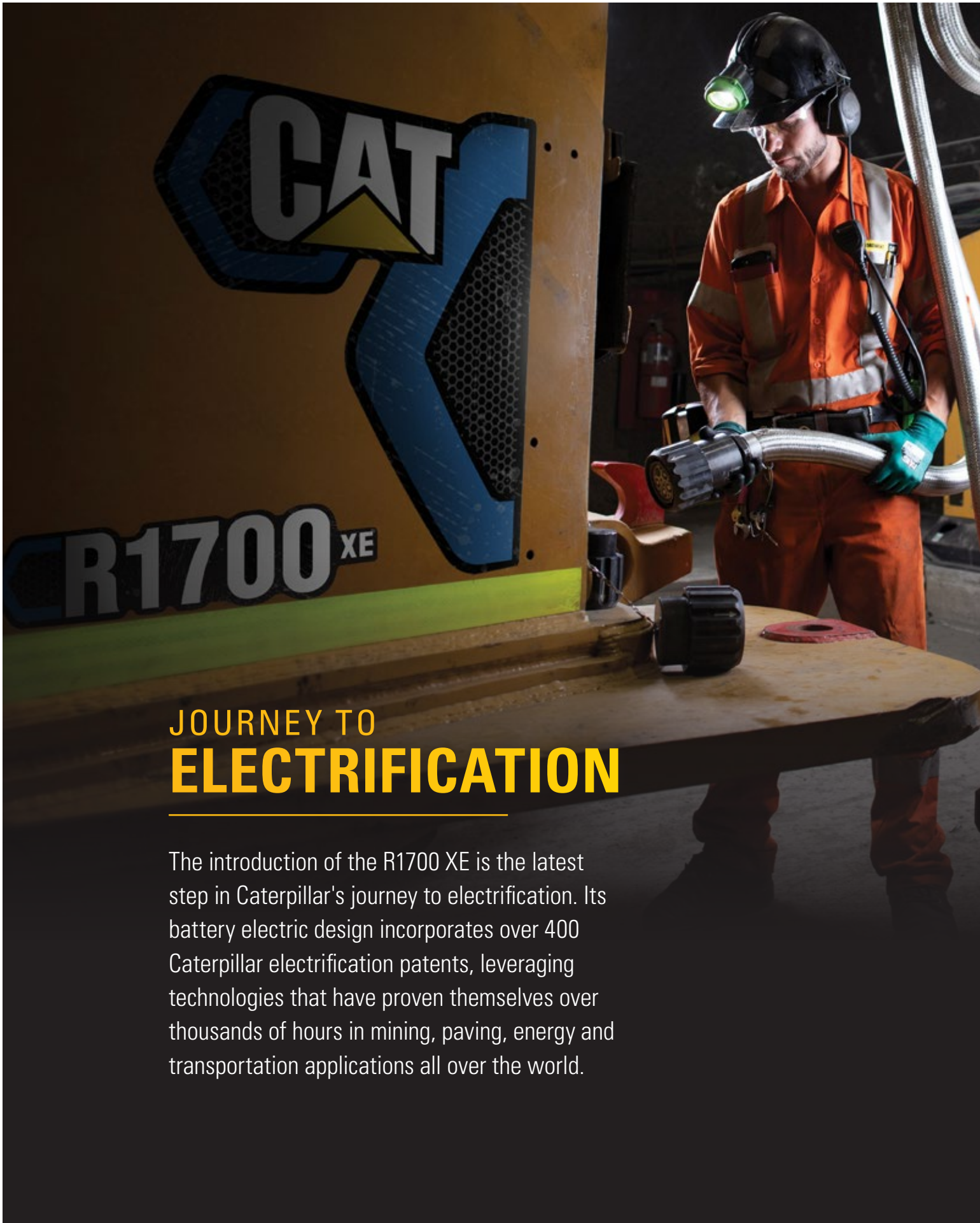

JOURNEY TO ELECTRIFICATION

The introduction of the R1700 XE is the latest step in Caterpillar's journey to electrification. Its battery electric design incorporates over 400 Caterpillar electrification patents, leveraging technologies that have proven themselves over thousands of hours in mining, paving, energy and transportation applications all over the world.

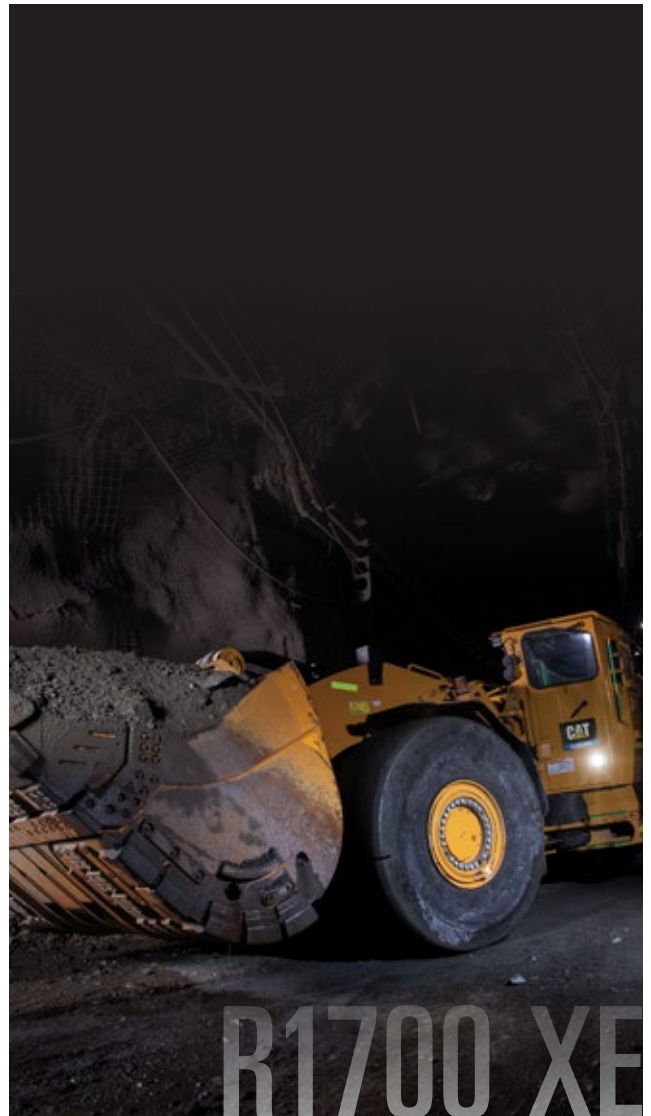

As mines dig deeper, development costs grow higher. It becomes increasingly difficult and costly to get clean and cool air. Recognizing the demand for a battery electric vehicle in deep, difficult-to-ventilate underground mines, we started with a proof-of-concept system on an R1300G in our proving ground facility. That machine was validated for more than 800 hours on a real mine site, and it demonstrated the potential of our onboard battery charging system.

The result of that project is the R1700 XE — a zero-emission battery electric loader that delivers the performance you expect from an industry-leading Cat machine. The R1700 XE generates significantly less heat and vibration as well as quieter performance.

ZERO-EMISSIONS BATTERY ELECTRIC POWER

The R1700 XE is designed to deliver safer, more productive and more efficient underground mining while helping miners meet sustainability goals and create a better working environment that improves employee health and safety.



ZERO DIESEL EMISSIONS

The R1700 XE is 100% powered by battery electric propulsion for zero diesel emissions and significantly less heat generation.

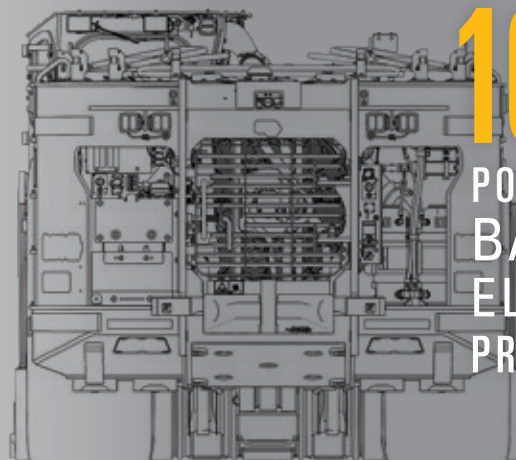

100%
POWERED BY
BATTERY
ELECTRIC
PROPULSION

SAFE, POWERFUL BATTERY

The R1700 XE battery is a proven and durable system for fast charging and high output. A Caterpillar engineered cooling system maximizes performance and battery life. Electrical safety is built into every level of the battery system. The battery is designed with multiple layers of redundancy and tested to global standards.

HIGH-EFFICIENCY ELECTRIC DRIVE SYSTEM

The R1700 XE features a proven switched reluctance (SR) electric drive system that is Caterpillar designed, integrated, validated and supported. The system offers reliability, ease of cooling and high performance. The benefits include:

- + Powerful pump drive SR motor for superior hydraulic performance, improved power and fast cycle times
- + Continuously variable speed control
- + Implemented virtual gears for machine controllability
- + Automatic retarding controls for maintaining speed on grade
- + Anti-rollback feature
- + Smoother directional changing, with no driveline or powertrain shock loads
- + Programmable speed management, which improves operator efficiency and reduces fatigue
- + Neutral creep and coasting inhibitor
- + Torque control, which reduces brake applications

ONBOARD FAST CHARGING

An industry first, the R1700 XE is powered by onboard batteries, which maximizes available run time. Charged by the Cat MEC500 Mobile Equipment Charger, the R1700 XE can be fully charged in 30 minutes—or in 20 minutes when two chargers are used in parallel. Onboard charging also improves safety by eliminating the need to handle batteries during charging.



—FULLY—
CHARGED IN
20
MINUTES

WHEN TWO CHARGERS
ARE USED IN PARALLEL

CHARGE
FAST.
CHARGE
SAFELY.
CHARGE
WHERE THE
WORK IS.

A first of its kind for the mining industry, the Cat MEC500 Mobile Equipment Charger is a standalone fast charging system designed to charge quickly and safely wherever it's needed. It can be towed, dragged or fork-lifted — eliminating the need for expensive static charging infrastructure. And it can fully charge the Cat® R1700 XE LHD in less than 30 minutes, or in 20 minutes when used in tandem. And it can fully charge the Cat® R1700 XE LHD in less than 30 minutes, or in 20 minutes when used in tandem.





OPTIMIZED CHARGING

The MEC500 is designed to charge quickly, with high power output (300-1,000 volts) and the ability to be used alone or in tandem for optimized charging. The charger boosts voltage to accommodate variable input voltages and offers an adjustable output current that can be used to trickle the charge. The MEC500 is capable of charging 500 kW (670 HP).

PORTABLE AND EASY TO USE

The MEC500 can be towed or forklifted and is available with an optional skid mount and lift eyes. It connects wherever there is mine power, and two units can charge in parallel with a single transformer. The charger features an easy, one-button start, and charging can be done by a single worker.

SAFETY-FOCUSED

The portable MEC500 quickly and easily charges batteries onboard the machine, so there is no need to handle or exchange them. The charger is equipped with multiple safety protocols with ground fault monitoring, continually regulating and protecting during the charging process.

RUGGED AND MINE-READY

The MEC500 charger is designed for challenging conditions like those found in underground mines.

- + Sealed against humidity with enclosed air conditioning
- + ISO2867 rock fall protected
- + IP66 rated for water and dust
- + Key components iso-mounted against vibration and seismic activity
- + Stainless steel flexible conduit protects against access to conductors
- + Ground fault monitoring on input from transformer and output to connector
- + Inverter features reliable Cat Microgrid power control



KEEP OPERATORS SAFE, COMFORTABLE & PRODUCTIVE

The R1700 XE underground loader has a lot of features operators appreciate — like its responsiveness, maneuverability, ergonomic joystick controls, and large, comfortable, climate-controlled cab. But what operators appreciate the most may be what it doesn't have: Zero diesel emissions. No engine heat. Less noise and vibration. Plus onboard batteries that can be safely charged without handling or exchanging them.

DESIGNED FOR COMFORT

The cab on the R1700 XE maintains the same footprint as previous generations; however, the interior has been completely redesigned with new space allotment for the operator and all new electronic components. The operator sits slightly lower inside the cab for improved ride quality and head room.

Ride control is now fully integrated into the hydraulic system and engages automatically as the machine goes above 5 kph (3 mph). Cylinders are electronically snubbed for protection and operator comfort.

Additional enhancements include:

- + New, adjustable padding for the operator's knees
- + Climate control standard with enclosed cab option
- + All new HVAC coverage with improved airflow, greater defrosting coverage and reduced noise levels
- + Isolation-mounted cab to reduce vibration transfer to the operator
- + Optional dual pane windows for reduced noise and improved temperature control in extreme ambient conditions
- + Cab pressurization to keep dust out

DESIGNED FOR SAFETY

With two emergency exits, improved camera options, in-cab fire suppression activation and more, the R1700 XE cab is built with the safety of your people in mind. The operator present system door sensor and latch sensor help ensure the safety of anyone working in, on or around the machine by preventing startup with no operator in the cab.

Operator present system with hydraulic system neutralization and door sensor
Improvements in visibility, lighting coverage and camera coverage
Integrated lock out/tag out points
In cab warnings – both visual and audible
Reverse alarm

Newly redesigned handrail system with full coverage for people on the work platform
Anti-slip tread on all walking surfaces

Front linkage pins for locking the lift arms in place

Tire pressure monitoring system

Ground-level access to most daily service checks

Dedicated fire suppression canister real estate and factory available
Multiple fire suppression activation points
Bolt-on tow hook

DESIGNED FOR CONTROL

The R1700 XE features auto retarding that is hydraulically actuated. As the name implies, the system comes on automatically when the operator's foot is lifted from the throttle. This feature improves cycle times as operators gain confidence and become more comfortable on downhill grades at faster speeds.

DESIGNED FOR RESPONSIVENESS

During the load or dump cycle, the harder the operator pushes the controls, the faster the machine responds. Performance is also enhanced by automated loading of the bucket with the Auto Dig feature. In addition, the steering system is pilot controlled to provide more acute feel for the operator as they maneuver in tight places.

INFORMATION DISPLAYS

A high-resolution display gives operators real-time system information in 11 different languages, keeping them up to date on performance and machine status even before the motor starts. The display can be integrated into your mine's communications network and comes ready for Product Link™ Elite data analysis and Cat® MineStar™ connectivity.

—THE—
RIGHT
TOOLS
FOR THE
JOB

OPTIMIZED BUCKET

Five bucket sizes are available for the R1700 XE, and all have been designed and manufactured to match its performance capabilities. Performance has never been better. We added strength to match improved breakout force and stiffness to the inside torque tube for torsional rigidity.

The result is a patented bucket design that offers load path management for long wear life, increased throat angle for easier loading in rock, and improved tire coverage for cleanup and tire protection.

Bolt-Together Convenience

Changing or equipping a new bucket is a complicated process. Just getting a complete bucket into the mine can be difficult. Transporting it from the entrance to the face involves carriers or forklifts that are needed for other tasks, and welding together the pieces requires hours of highly skilled labor.

One of the R1700 XE's five bucket sizes — the 6.8 m³ (8.9 yd³) option — is available in a bolt-together option created to solve these problems. It cuts replacement times by up to 75%.



FLEXIBLE AND RELIABLE GROUND ENGAGING TOOLS

Caterpillar offers a number of Ground Engaging Tool (GET) options for the R1700 XE, so you can customize your machine to meet your site-specific needs and fit with your overall maintenance strategy. Whether you choose welded, bolted or hammerless, Cat GET helps you achieve the productivity and the bucket life you desire. In addition, Cat Bucket Pro can help you manage GET performance and optimize bucket lifecycle costs. All Cat GET are built for strength and long life, so you spend less time replacing shrouds.

BOLT-ON HALF ARROW GROUND ENGAGING TOOLS

For the entire underground loader line, Caterpillar now offers Bolt On Half Arrow ground engaging tools (GET) for bucket edges. The system is designed for high abrasion applications where weld-on GET experience high wear rates. With a proven and reliable retention system, the bolt-on GET offer more wear material than standard weld-on GET, and the bolt-on design enables fast and easy removal and replacement. Despite additional wear material, the low-profile front edge eases pile penetration and promotes fast bucket loading.

BOHA GET can reduce changeout times while extending the life of traditional weld-on GET option — allowing the R1700's new bucket design to perform even better in heavy, hard-digging rock conditions. BOHA GET are bolted onto the bucket instead of welded — shortening replacement time from as much as 40 hours to as little as one or two. And with no need for welding, they are easier to replace.

DURILOCK™ LIP SHROUD SYSTEM

The new Durilock Lip Shroud system for underground loader buckets is a flexible, productive option for all Cat underground LHDs. This new system features hammerless installation and maintenance-free retention of GET. Three interchangeable shroud styles allow you to configure your loader to its current application needs — without stopping to change the base edge or retention system.

- + Standard — Wedge shape for general production and development
- + Abrasion — Contoured to put more material on the shroud base
- + Penetration — Less leading-edge material to easily penetrate dense material



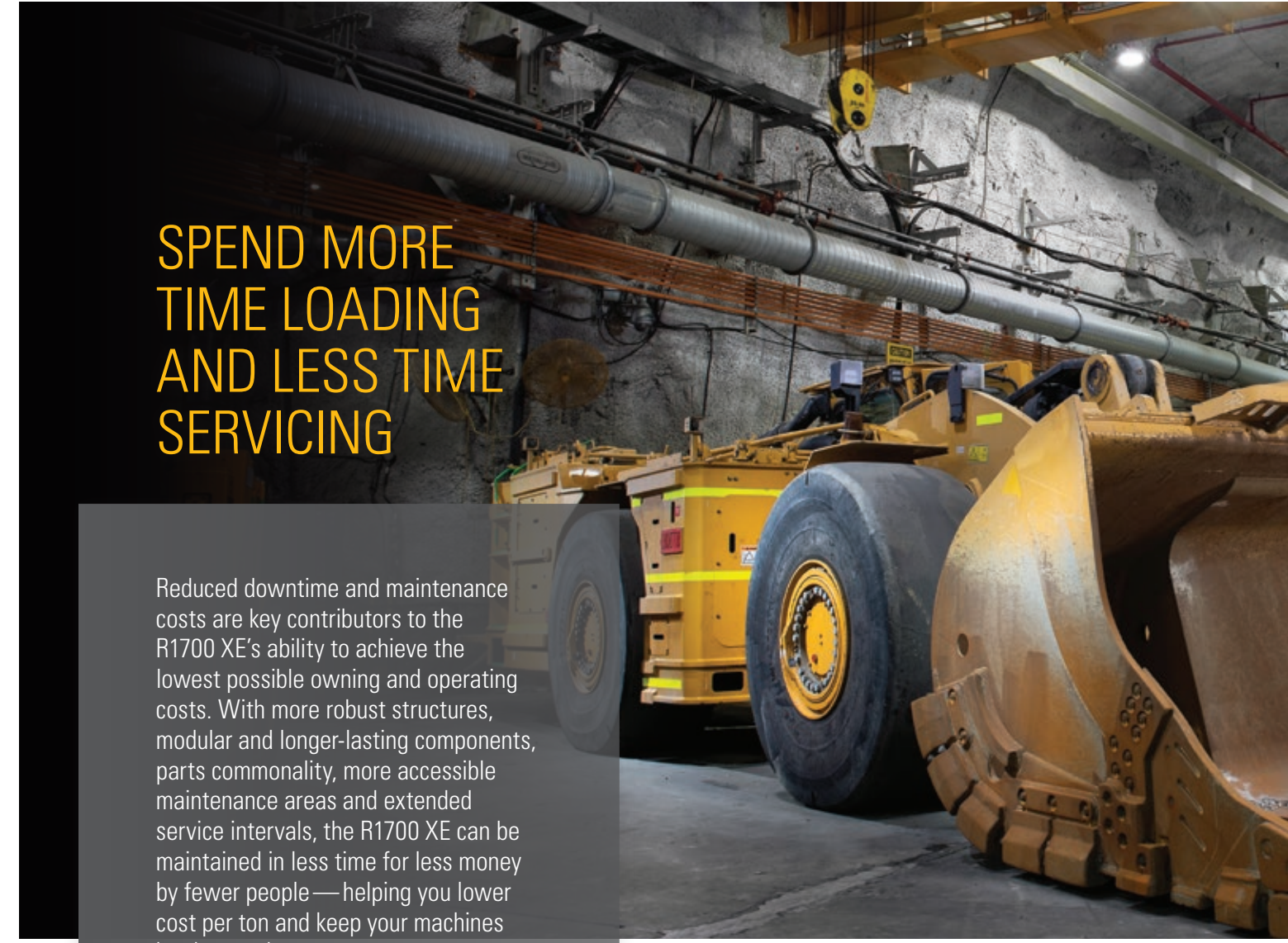

SPEND MORE TIME LOADING AND LESS TIME SERVICING

Reduced downtime and maintenance costs are key contributors to the R1700 XE's ability to achieve the lowest possible owning and operating costs. With more robust structures, modular and longer-lasting components, parts commonality, more accessible maintenance areas and extended service intervals, the R1700 XE can be maintained in less time for less money by fewer people — helping you lower cost per ton and keep your machines hard at work.

MODULAR AND LONGER LIFE COMPONENTS

The R1700 XE features several components — like the HVAC system and the cooling system — as modular designs that can be removed from the machine as a single unit and slotted back into place as a single unit, allowing the machine to get back into service much more quickly. Similarly, all machine ECMs are in a single, well protected and sealed box accessible from the work platform.

In addition, the R1700 XE Electric shares strong parts commonality with the R1700, making it possible for mines that currently have R1700s to reduce their parts inventory by using those parts on the R1700 XE.

IMPROVED SERVICE ACCESS

All filter and key service tasks have been grouped into a centralized service section. The radiator guard swings open for ground-level access to the radiator, and oil coolers and the batteries are easily accessed just under the centralized service location.

BUILT TO BE REBUILT

The R1700 XE's frame, powertrain and components are all built to be rebuilt — using new, remanufactured or rebuilt parts and components — so you can take advantage of multiple lives of like-new performance at a fraction-of-new price. Reused or remanufactured components can deliver additional cost savings.



STRONG AND ROBUST

The R1700 XE is a strong, robust machine — which is clearly reflected in the design of its structures. Using the latest engineering design and validation tools, we've given this frame strength where it needs it most, and saved weight in other locations.

The front frame section has a new four plate design with a new, fully integrated front axle support casting at its base. This new casting absorbs greater impact, vibration and tram loads that come with the growth of the machine capacity and weight.

The lift arms on the R1700 XE are visibly stronger with additional steel thicknesses in key areas. This new design allowed us to widen access to service points to the front frame and hydraulic components. Bucket linkage, cylinder attachment points and cylinder sizes have been updated to greatly improve the mechanics of loading.

DOWNTIME-REDUCING FEATURES

- + Lubrication options fitted from the factory
- + Brake release and tow hook option that allows you to remove the machine and disengage the park brake.
- + Redesigned hitch with more space for technicians and clean & simplified hydraulic routings
- + Electric drive system with fewer moving parts and extended maintenance intervals
- + Sealed electrical connectors, which lock out dust and moisture
- + Hardened and sealed electronics and ECMs
- + Scheduled Oil Sampling, which helps keep minor repairs from becoming major ones
- + Added remote mounted test ports for testing and troubleshooting



ENHANCED BY TECHNOLOGY

Cat® MineStar™ Solutions for underground

The R1700 XE leaves the factory ready for MineStar, the mining industry's most comprehensive suite of technology offerings.

BOOST SAFETY, PRODUCTIVITY & UTILIZATION THROUGH AUTONOMOUS OPERATION

Integrating the industry-proven Cat® MineStar™ Command for underground, the R1700 XE offers multiple levels of autonomy through Caterpillar's scalable autonomous solution, including line-of-sight remote, teleremote operation, and co-pilot, which requires only directional input from the operator. This building block approach allows you to capture value at your most economic entry point while allowing scalability as technology maturity grows.

Command for underground enables remote operation of load-haul-dump machines—from simple line-of-sight to full autonomy—providing immediate productivity and efficiency gains and improving safety. Command allows you to relocate operators to a safe, comfortable location underground or

on the surface. Automation improves accuracy of tunnel navigation, boosting productivity and reducing machine damage caused by contact with drive walls.

FULLY AUTONOMOUS OPERATION

The addition of three new controls enable fully autonomous operation of the R1700 XE.

- + Auto Pilot, which oversees tramming of the machine without input between the load and dump points.
- + Auto Dump, which allows the machine to dump into a fixed infrastructure without operator input.
- + Auto Dig, which enables autonomous digging and bucket loading.

GET ESSENTIAL OPERATIONAL INFORMATION

with MineStar Fleet for underground

Timely access to accurate information is key to running a productive mine. Fleet for underground provides real-time visibility to cycle time, payload, machine position and other key operational parameters and automatically records and tracks data up and down the value chain. Fleet can help you better understand machine usage, improve shift changes, manage tasks, maximize operational efficiency and more.

MAKE INFORMED DECISIONS AND OPTIMIZE YOUR MAINTENANCE STRATEGY

with MineStar Health

Machine health data is critical to helping you improve the reliability of your mining equipment, reduce unplanned downtime and prevent costly failures. MineStar Health products and services enable you to collect and transmit equipment data that enables proactive maintenance services and predictive equipment analysis. By staying connected with your machines, you can head off small problems while they're still small and keep your machines running as efficiently as possible as long as possible.

ADDRESS RISKS TO PEOPLE AND ASSETS

with MineStar Detect for underground

Detect prevents unintended interactions between people and assets by letting you “see” in the dark. Using a high-precision peer-to-peer proximity detection system coupled with a revolutionary communications and tracking network, Detect can prevent incidents and track people and machines—wherever they are underground—in real time and with no reliance on mine infrastructure. It provides operators continuous awareness of their surroundings to sub-meter accuracy, along with the location and status of all personnel and assets.



CAT PRODUCT LINK™ ELITE

Product Link™ Elite system boosts connectivity and increases the availability of data provided by the R1700 XE. The on-board hardware enables the loader to collect and transmit information into locally hosted or cloud-hosted applications such as MineStar Health Office, Health Equipment Insights, Equipment Care Advisor or Vision Link. The system opens the door for industry-leading equipment health and condition monitoring services from Caterpillar and your local Cat dealer.



MINING — FOR A — **BETTER WORLD**

Governments and regulatory agencies mandate that you establish and follow environmentally sound policies and practices as you meet the demand for mined materials. We're focused on doing our part to make sure our machines help you meet those regulations. Every piece of Cat equipment is designed to be better and do better. Because the better we mine, the better the world can be.

At Caterpillar, we continue to research alternative energy sources such as biofuels and liquefied natural gas and power options like electrification to find new ways to reduce emissions. Underground mining continues to be an early adopter of sustainable mobile equipment solutions, based on the need for a clean and safe working environment. The battery electric R1700 XE is a key part of the vision to an all-electric mine.

In addition, we rebuild and remanufacture parts, components and complete machines to increase the lifespan of equipment—reusing instead of discarding, conserving energy, reducing waste, keeping nonrenewable resources in circulation for multiple lifetimes and minimizing the need for new raw materials. We're also listening to our customers and investigating ways we can help them in their efforts to recycle end-of-life machines and components.

Retrofits and upgrades enhance and improve older machines to incorporate efficiency improvements and emission reductions, and to keep them in production longer to conserve energy, lower emissions and minimize the need for raw materials.





SUPPORTING YOU UNDERGROUND: A TEAM THAT LISTENS, CUSTOMIZES & COLLABORATES

YOUR PARTNER FOR THE COMPLETE EQUIPMENT LIFECYCLE

No one knows more about how to get the most from a piece of Cat equipment than Caterpillar and your local Cat dealer. Our partnership starts with validation and testing of the machine and continues through the complete lifecycle of the loader.

The one-of-a-kind Cat dealer support network delivers expert service, integrated solutions, after-sales support, fast and efficient parts fulfillment, world-class rebuild and remanufacturing capabilities and more.

Cat dealers operate as nearly 200 local businesses—each one fully embedded in and committed to the geographic area it serves. That means you work with people you know, who know your business, and who respond on your timeframe.

Caterpillar and Cat dealer personnel will partner with you on site to improve the performance not only of your LHD but of your overall loading and hauling operation.

You'll have access to parts and service, as well as technicians who are focused on helping you optimize repairs to keep machines productive. And we help with training to ensure your operators have the skills and knowledge they need to work as efficiently and productively as possible.

We also work alongside you to ensure you achieve maximum value throughout the life of your equipment. Together with our Cat dealer network, we customize service offerings to provide a maintenance solution that fits your operation—whether you want to perform the majority of service yourself, or you're looking for an onsite partner to manage your maintenance organization. We're also consultants who can help you make smart decisions about buying, operating, maintaining, repairing, rebuilding and replacing equipment.

TECHNICAL SPECIFICATIONS: R1700 XE

See cat.com for complete specifications.



OPERATING SPECIFICATIONS		
Rated Payload	15,000 kg	33,069 lb
Operating Mass	48,743 kg	107,460 lb
Shipping weight	51,918 kg	114,460 lb
Static Tipping Load Straight Ahead, Lift Arms Horizontal (calculated)	49,203 kg	108,500 lb
Static Tipping Load Full Turn, Lift Arms Horizontal (calculated)	40,649 kg	89,600 lb
Break Out Force (Lift and Tilt)	24,190 kg	53,300 lb
Ride Control	Yes	
Bucket Capacity Range	5.7 - 7.5 m ³	7.5 - 9.8 yd ³

HYDRAULIC SYSTEM LIFT/TILT		
Lift/Tilt System – Circuit	Electro-Hydraulic, Postive Flow Control, Flow Sharing	
Lift/Tilt System – Pump	Variable Flow Piston / Hydraulic Load Sense	
Maximum Flow	297 L/min	78.5 gal/min
Relief Valve Setting – Main	34000 kPa	4932 psi
Lift Cylinder – Bore	170 mm	7 in
Lift Cylinder – Stroke	830 mm	33 in
Tilt Cylinder – Bore	210 mm	8 in
Tilt Cylinder – Stroke	564 mm	22 in

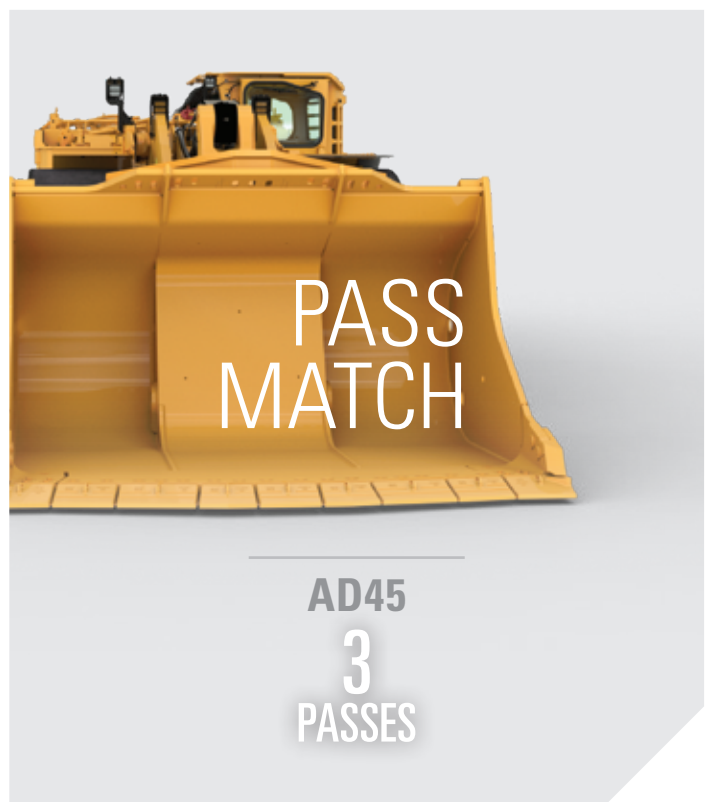

TECHNICAL SPECIFICATIONS: R1700 XE

See cat.com for complete specifications.

HYDRAULIC CYCLE TIMES	
Raise	6.8 seconds
Dump	3.3 seconds
Lower, Empty, Float Down	2.9 seconds
Total Cycle Time	13.2 seconds

TRACTION MOTOR			
Motor Type	Switched Reluctance		
Rated Power – peak	250kW	335 hp	
Rated Power – nominal	220kW	295 hp	
Rated Torque (peak, nominal=@12kph [7.5mph] and nominal power)	3200Nm / 660Nm	2360 lbf-ft / 443 lbf-ft	
Efficiency	95%		
Cooling method	Liquid		
Ability of regenerative braking	Yes		
Service Interval	12,000 – 13,000		

AUXILIARY MOTOR			
Motor Type	Switched Reluctance		
Rated Power (peak, nominal)	226kW	303 hp	
Rated Torque (peak, nominal=1600 equiv. rpm)	600Nm / 531Nm	443 lbf-ft / 392 lbf-ft	
Efficiency	96%		
Cooling method	Liquid		
Service Interval	12,000 – 13,000		

POWER ELECTRONICS	
Inverter rating	350A(nominal DC), 715VDC
Cooling method	Liquid (Coolant)
Component ratings	IP67, IP69K
Service Interval	12,000 – 13,000

GRADE PERFORMANCE					
25 degree Ambient, 2% Rolling Resistance					
Grade (%)	0	5	10	15	20
Loaded – km/h (mph)	18 (11.2)	14.8 (9.2)	8.6 (5.3)	6.1 (3.8)	4.8 (3)
Unloaded – km/h (mph)	18 (11.2)	18 (11.2)	11.1 (6.9)	7.9 (4.9)	6.2 (3.9)

BATTERY PACK	
Battery Chemistry	Li-Ion
Battery monitoring	with integrated Caterpillar controls systems
Pack voltage – nominal	715 V
Pack energy capacity – total	213 kWh
Charging method	Ultra Fast Charge Onboard
Onboard Fast Charging Charge time (0-100%)	less than 20 min (two MEC500 in parallel) less than 30 min (one MEC500)
Battery cooling method	Chilled Liquid (Extended Life Coolant)
Operating temperature limits (ambient)	50°C / -20°C 122 ° F / 68° F
Charging Current, Voltage	1160A (output), 820VDC
Maximum Charging Rate	840kW (two MEC500 chargers)
Minimum Charging Rate	500kW
Charging rate	Up to 4C (matched with MEC500 chargers)

TECHNICAL SPECIFICATIONS: MEC500 CHARGER

See cat.com for complete specifications.



WEIGHTS

MEC500	1,656 kg	3,650 lb
MEC500 with Optional Skid	2,037 kg	4,490 lb

ELECTRICAL SPECIFICATIONS

Rated Power (AC Input)	500 kW
Rated Current (DC Output)	700 Amps
Input Voltage Range	400-660 VAC
Voltage Output	300-1,000 VAC
Frequency Range	45-65 Hz
Input Supply (AC Input)	3-Phase Insulated Terra (IT)
Cable Output	
Cat Proprietary Connector	700 Amp

THERMAL SPECIFICATIONS

Ambient Operating Temperature Range	-25° to +50° C	13° to 122° F
Storage	-40° to +80° C	-40° to +176° F

CHARGING STANDARDS

Control Interface	CAN
Control Type	IEC 61851-23/24 (with CAN)
Compliance and Safety	CSA M421; UL2202 (under development)

STANDARD AND OPTIONAL EQUIPMENT

Standard and optional equipment may vary. Consult your Cat dealer for details.

POWER TRAIN		
	Standard	Optional
Brake axle cooling	x	
Brakes, full hydraulic enclosed wet multiple-disc (SAFR)	x	
Machine Power Source:		
Battery	x	
2 independently controlled motors for propulsion and hydraulics	x	
Reversible hydraulic steering		x
Fast fill and evacuation of fluids (Powertrain and Hydraulic)		x

ELECTRICAL		
	Standard	Optional
Alarm, reversing	x	
Alternate implement control functions		x
DC-DC convertor, 8 Amp	x	
24V Battery disconnect switch, ground level		x
24 V Battery isolation switch in the cab		x
24V Batteries, low maintenance	x	
HV indication lamp	x	
HV battery disconnect switch	x	
Diagnostic connector	x	
Lighting, external, front, rear (LED)	x	
Lighting, stop, dual (LED)	x	

TIRES, RIMS AND WHEELS		
	Standard	Optional
Tires	x	
Rims (set of four):		
Five piece	x	
Spare rim		x

TECHNOLOGY		
	Standard	Optional
Traction control	x	
Cat Auto Dig		x
Ride control		x
Tire pressure monitoring		x
Cat payload monitoring		x
Product Link Elite System	x	
Product Link Elite with WiFi**		x
Cat line of sight remote receiver for the machine		x
Cat line of sight remote console (over the shoulder design)		x
Wireless communications control group		x

** Confirm regional availability with your Cat dealer.

OPERATOR ENVIRONMENT		
	Standard	Optional
Enclosed Cab, ROPS/FOPS certified.	x	
Color Multi Purpose Display (CMPD):		
Front and rear brake gauges	x	
System diagnostics	x	
Residual brake warning	x	
Horns, electric	x	
Instrumentation/gauges:		
Speedometer/tachometer	x	
Battery SOC (State of Charge) level	x	
Hydraulic oil temperature	x	
Battery & PTO coolant temperature	x	
Operator presence system	x	
Automatic Brake Application (ABA)	x	
Light, warning, residual brake	x	
Monitor, door latch	x	
Electrohydraulic implement controls (single joystick)	x	
Seat belt, retractable	x	
Mounts, radio and speaker (x2)	x	
Storage box, enclosed, 5 L (3 gal)	x	
Armrests and kneepads, independently adjustable	x	
Color rear view camera		x

OTHER EQUIPMENT		
	Standard	Optional
Autolube		x
Ansul fire suppression – wet 37 L (9.8 gal)		x
Bolt-on, brake release recovery bar or hook		x
Dump bucket	x	
Bolt-together bucket		x
Bolt-on bucket lips		x
Lift arm positioner for return to dig	x	
Service bay light		x
Truck loading light		x

CAB		
Choose between:		
1. Standard height		
2. Raised height		



R1700 XE LOADER

For more complete information on Cat products, dealer services and industry solutions, visit us at www.cat.com

PEDJ0856-01

Materials and specifications are subject to change without notice. Featured machines in photos may include additional equipment. See your Cat dealer for available options.

© 2024 Caterpillar. All Rights Reserved. CAT, CATERPILLAR, LET'S DO THE WORK, their respective logos, "Caterpillar Corporate Yellow", the "Power Edge" and Cat "Modern Hex" trade dress as well as corporate and product identity used herein, are trademarks of Caterpillar and may not be used without permission.

