

Operation and Maintenance Manual

**904J-E36TA, 904J-E28T, and 904J-
E28TA Industrial Engines**

Important Safety Information

Most accidents that involve product operation, maintenance and repair are caused by failure to observe basic safety rules or precautions. An accident can often be avoided by recognizing potentially hazardous situations before an accident occurs. A person must be alert to potential hazards. This person should also have the necessary training, skills and tools to perform these functions correctly.

Incorrect operation, lubrication, maintenance or repair of this product can be dangerous and could result in injury or death.

Do not operate or perform any lubrication, maintenance or repair on this product, until you have read and understood the operation, lubrication, maintenance and repair information.

Safety precautions and warnings are provided in this manual and on the product. If these hazard warnings are not heeded, bodily injury or death could occur to you or to other persons.

The hazards are identified by the "Safety Alert Symbol" and followed by a "Signal Word" such as "DANGER", "WARNING" or "CAUTION". The Safety Alert "WARNING" label is shown below.



The meaning of this safety alert symbol is as follows:

Attention! Become Alert! Your Safety is Involved.

The message that appears under the warning explains the hazard and can be either written or pictorially presented.

Operations that may cause product damage are identified by "NOTICE" labels on the product and in this publication.

Perkins cannot anticipate every possible circumstance that might involve a potential hazard. The warnings in this publication and on the product are, therefore, not all inclusive. You must not use this product in any manner different from that considered by this manual without first satisfying yourself that you have considered all safety rules and precautions applicable to the operation of the product in the location of use, including site-specific rules and precautions applicable to the worksite. If a tool, procedure, work method or operating technique that is not specifically recommended by Perkins is used, you must satisfy yourself that it is safe for you and for others. You should also ensure that you are authorized to perform this work, and that the product will not be damaged or become unsafe by the operation, lubrication, maintenance or repair procedures that you intend to use.

The information, specifications, and illustrations in this publication are on the basis of information that was available at the time that the publication was written. The specifications, torques, pressures, measurements, adjustments, illustrations, and other items can change at any time. These changes can affect the service that is given to the product. Obtain the complete and most current information before you start any job. Perkins dealers or Perkins distributors have the most current information available.



When replacement parts are required for this product Perkins recommends using Perkins replacement parts.

Failure to heed this warning can lead to premature failures, product damage, personal injury or death.

In the United States, the maintenance, replacement, or repair of the emission control devices and systems may be performed by any repair establishment or individual of the owner's choosing.

Table of Contents

Foreword	4	Engine Operation	76
Safety Section		Aftertreatment Operation.....	79
Safety Messages.....	6	Cold Weather Operation	86
Safety Messages.....	9	Engine Stopping	90
Safety Messages.....	12	Maintenance Section	
Additional Messages	16	Refill Capacities.....	92
General Hazard Information.....	17	Maintenance Recommendations	111
Burn Prevention.....	21	Maintenance Interval Schedule.....	114
Fire Prevention and Explosion Prevention.....	23	Warranty Section	
Crushing Prevention and Cutting Prevention..	25	Warranty Information.....	164
Mounting and Dismounting	25	Reference Information Section	
High Pressure Fuel Lines	25	Reference Materials	165
Before Starting Engine	27	Index Section	
Engine Starting	27	Index.....	167
Engine Stopping	28		
Electrical System.....	28		
Engine Electronics.....	29		
Product Information Section			
General Information	31		
Product Identification Information	49		
Operation Section			
Lifting and Storage	51		
Features and Controls.....	56		
Engine Diagnostics	70		
Engine Starting.....	72		

Foreword

California Proposition 65 Warning

Diesel engine exhaust and some of its constituents are known to the State of California to cause cancer, birth defects, and other reproductive harm.



WARNING – This product can expose you to chemicals including ethylene glycol, which is known to the State of California to cause birth defects or other reproductive harm. For more information go to:

www.P65Warnings.ca.gov

Do not ingest this chemical. Wash hands after handling to avoid incidental ingestion.



WARNING – This product can expose you to chemicals including lead and lead compounds, which are known to the State of California to cause cancer, birth defects, or other reproductive harm. For more information go to:

www.P65Warnings.ca.gov

Wash hands after handling components that may contain lead.

Literature Information

This manual contains safety, operation instructions, lubrication, and maintenance information. This manual should be stored in or near the engine area in a literature holder or literature storage area. Read, study, and keep the manual with the literature and engine information.

English is the primary language for all Perkins publications. The English used facilitates translation and consistency.

Some photographs or illustrations in this manual show details or attachments that may be different from your engine. Guards and covers may have been removed for illustrative purposes. Continuing improvement and advancement of product design may have caused changes to your engine which are not included in this manual. Whenever a question arises regarding your engine, or this manual, please consult with your Perkins dealer or your Perkins distributor for the latest available information.

Safety

This safety section lists basic safety precautions. In addition, this section identifies hazardous, warning situations. Read and understand the basic precautions listed in the safety section before operating or performing lubrication, maintenance, and repair on this product.

Operation

Operating techniques outlined in this manual are basic. The operating techniques assist with developing the skills and techniques required to operate the engine more efficiently and economically. Skill and techniques develop as the operator gains knowledge of the engine and the capabilities of the engine.

The operation section is a reference for operators. Photographs and illustrations guide the operator through procedures of inspecting, starting, operating, and stopping the engine. This section also includes a discussion of electronic diagnostic information.

Maintenance

The maintenance section is a guide to engine care. The illustrated, step-by-step instructions are grouped by service hours and/or calendar time maintenance intervals. Items in the maintenance schedule are referenced to detailed instructions that follow.

Recommended service should be performed at the appropriate intervals as indicated in the Maintenance Interval Schedule. The actual operating environment of the engine also governs the Maintenance Interval Schedule. Therefore, under severe, dusty, wet, or freezing cold operating conditions, more frequent lubrication, and maintenance than is specified in the Maintenance Interval Schedule may be necessary.

The maintenance schedule items are organized for a preventive maintenance management program. If the preventive maintenance program is followed, a periodic tune-up is not required. The implementation of a preventive maintenance management program should minimize operating costs through cost avoidances resulting from reductions in unscheduled downtime and failures.

Maintenance Intervals

Perform maintenance on items at multiples of the original requirement. Each level and/or individual items in each level should be shifted ahead or back depending upon your specific maintenance practices, operation, and application. Perkins recommends that the maintenance schedules be reproduced and displayed near the engine as a convenient reminder. Perkins also recommends that a maintenance record be maintained as part of the permanent record of the engine.

Your authorized Perkins dealer or your Perkins distributor can assist you in adjusting your maintenance schedule to meet the needs of your operating environment.

Overhaul

Major engine overhaul details are not covered in the Operation and Maintenance Manual except for the interval and the maintenance items in that interval. Major repairs are best left to trained personnel or an authorized Perkins distributor or dealer. Your Perkins dealer or your Perkins distributor offers various options regarding overhaul programs. If you experience a major engine failure, there are also numerous after failure overhaul options available. Consult with your Perkins dealer or your Perkins distributor for information regarding these options.

Safety Section

i07943830

Safety Messages

There may be several specific warning signs on your engine. The exact location and a description of the warning signs are reviewed in this section. Ensure that you are familiar with all warning signs.

Ensure that all the warning signs are legible. Clean the warning signs or replace the warning signs if the words cannot be read or if the illustrations are not visible. Use a cloth, water, and soap to clean the warning signs. Do not use solvents, gasoline, or other harsh chemicals. Solvents, gasoline, or harsh chemicals could loosen the adhesive that secures the warning signs. The warning signs that are loosened could drop off the engine.

Replace any warning sign that is damaged or missing. If a warning sign is attached to a part of the engine that is replaced, install a new warning sign on the replacement part. Your Perkins dealer or your Perkins distributor can provide new warning signs.

904J-E36TA Industrial Engine

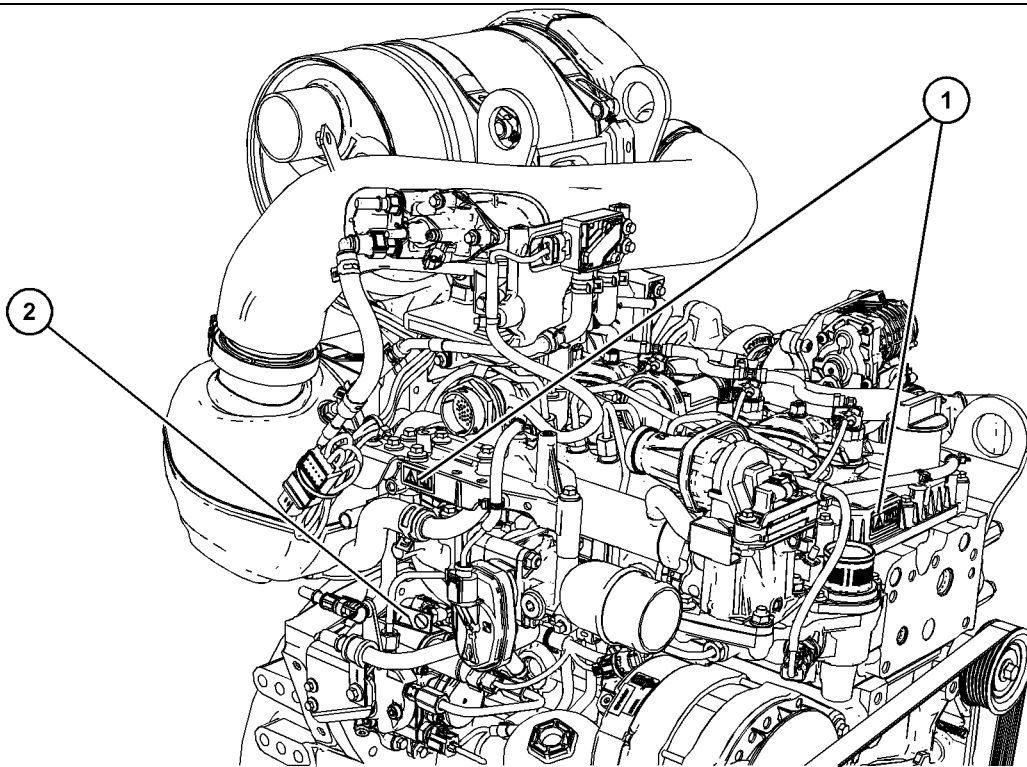

Illustration 1
Typical example

g06296038

904J-E28T and 904J-E28TA Industrial Engines

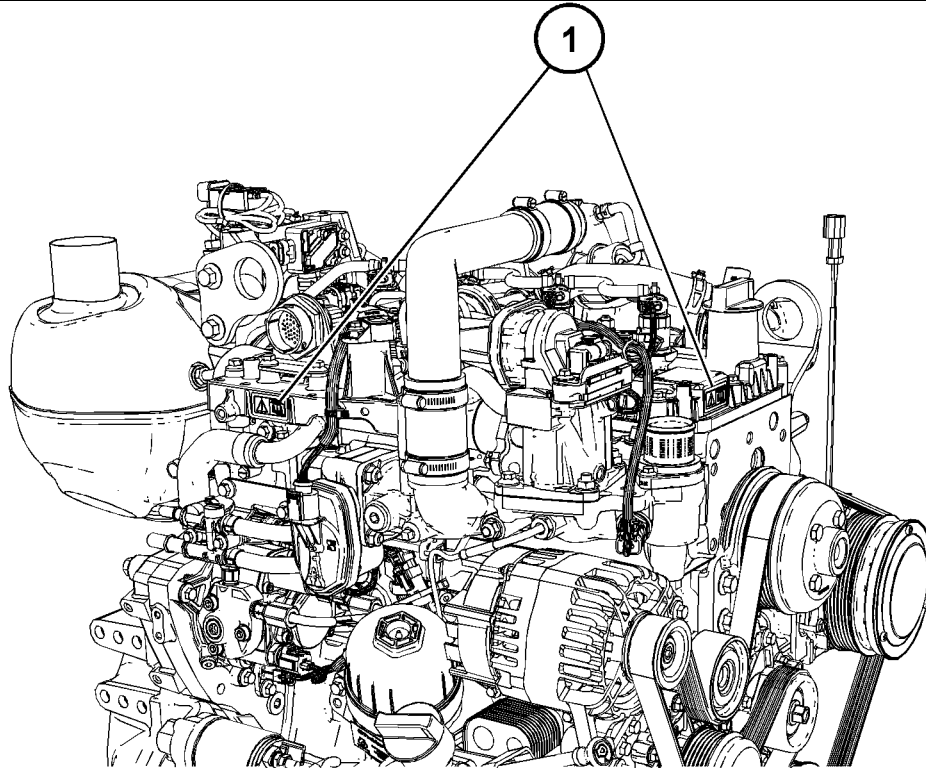

Illustration 2

Typical example

g06458556

Universal Warning 1

 **WARNING**

Do not operate or work on this equipment unless you have read and understand the instructions and warnings in the Operation and Maintenance Manuals. Failure to follow the instructions or heed the warnings could result in serious injury or death.

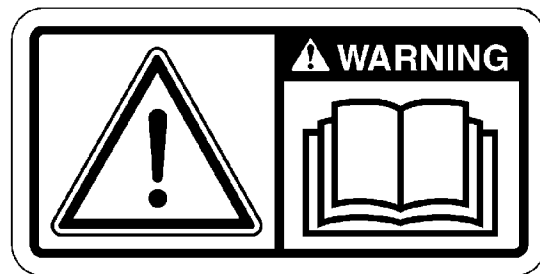

Illustration 3

Typical example

g01154807

The universal warning labels are located in two positions. One label is on the front over the engine, the other label is on the right side of the engine.

Hand (High Pressure) 2

WARNING

Contact with high pressure fuel may cause fluid penetration and burn hazards. High pressure fuel spray may cause a fire hazard. Failure to follow these inspection, maintenance and service instructions may cause personal injury or death.



Illustration 4

g02382677

Typical example

The hand high-pressure label is on the high-pressure fuel line between pump and manifold, on the right side of the engine.

Ether Warning

WARNING

Do not use aerosol types of starting aids such as ether. Such use could result in an explosion and personal injury.



Illustration 5

g01154809

Typical example

The ether warning label is installed on the air cleaner close to the intake. The location will depend on the application. In some applications, the ether label will be supplied loose for fitting by the engine installer.

i08022376

Safety Messages

There may be several specific warning signs on your engine. The exact location and a description of the warning signs are reviewed in this section. Ensure that you are familiar with all warning signs.

Ensure that all the warning signs are legible. Clean the warning signs or replace the warning signs if the words cannot be read or if the illustrations are not visible. Use a cloth, water, and soap to clean the warning signs. Do not use solvents, gasoline, or other harsh chemicals. Solvents, gasoline, or harsh chemicals could loosen the adhesive that secures the warning signs. The warning signs that are loosened could drop off the engine.

Replace any warning sign that is damaged or missing. If a warning sign is attached to a part of the engine that is replaced, install a new warning sign on the replacement part. Your Perkins dealer or your Perkins distributor can provide new warning signs.

904J-E36TA Industrial Engines With A Balancer

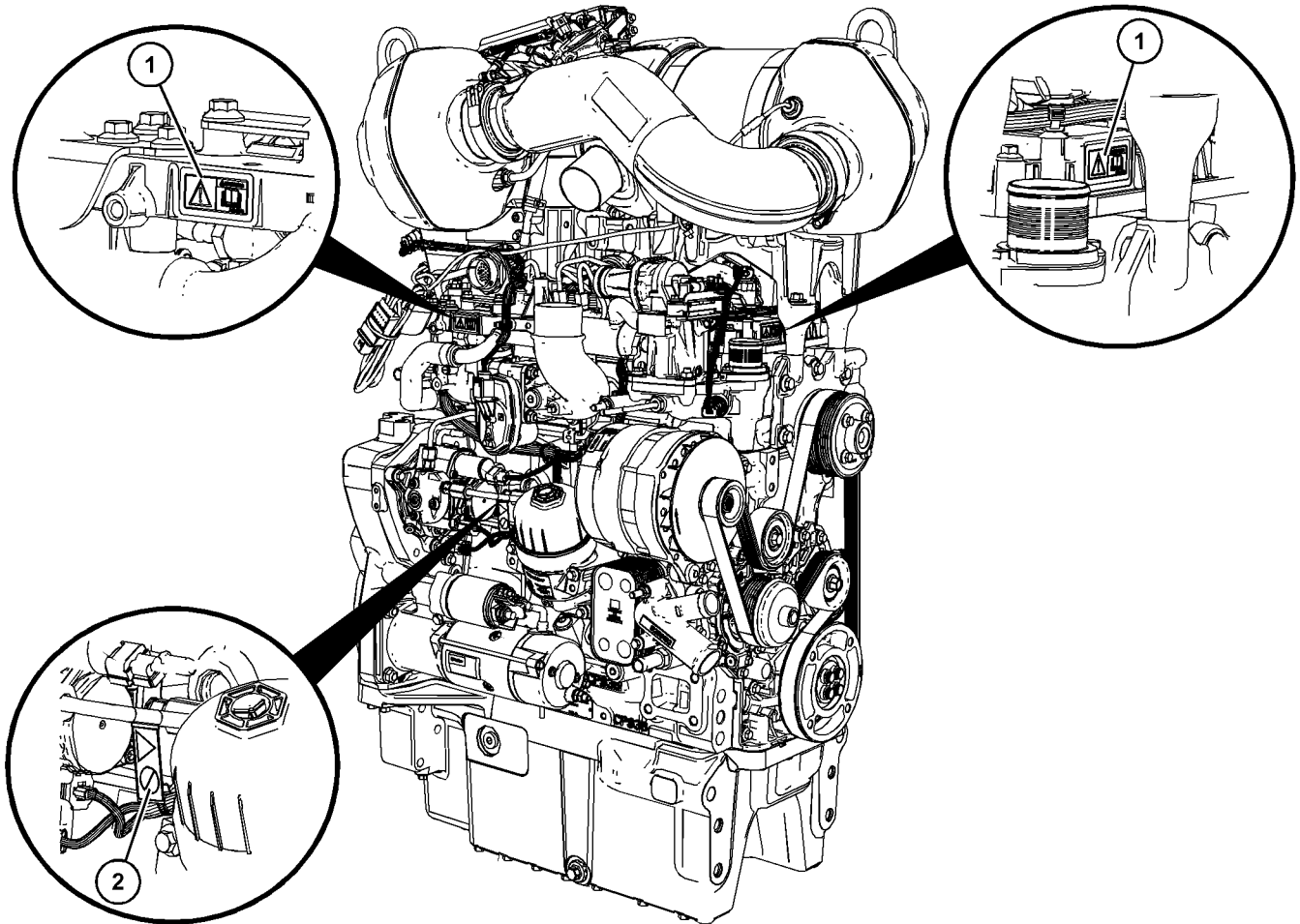

Illustration 6
Typical example

g06510918

Universal Warning 1

⚠ WARNING

Do not operate or work on this equipment unless you have read and understand the instructions and warnings in the Operation and Maintenance Manuals. Failure to follow the instructions or heed the warnings could result in serious injury or death.

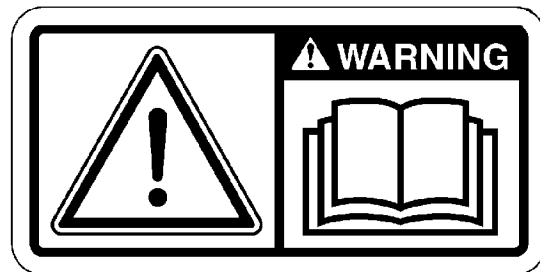

Illustration 7
Typical example

g01154807

The universal warning labels are located in two positions. One label is on the front over the engine, the other label is on the right side of the engine.

Hand (High Pressure) 2



Contact with high pressure fuel may cause fluid penetration and burn hazards. High pressure fuel spray may cause a fire hazard. Failure to follow these inspection, maintenance and service instructions may cause personal injury or death.



Illustration 8

g02382677

Typical example

The hand high-pressure label is on the high-pressure fuel line between pump and manifold, on the right side of the engine.

Ether Warning



Do not use aerosol types of starting aids such as ether. Such use could result in an explosion and personal injury.



Illustration 9

g01154809

Typical example

The ether warning label is installed on the air cleaner close to the intake. The location will depend on the application. In some applications, the ether label will be supplied loose for fitting by the engine installer.

i09951633

Safety Messages

There may be several specific warning signs on your engine. The exact location and a description of the warning signs are reviewed in this section. Ensure that you are familiar with all warning signs.

Ensure that all the warning signs are legible. Clean the warning signs or replace the warning signs if the words cannot be read or if the illustrations are not visible. Use a cloth, water, and soap to clean the warning signs. Do not use solvents, gasoline, or other harsh chemicals. Solvents, gasoline, or harsh chemicals could loosen the adhesive that secures the warning signs. The warning signs that are loosened could drop off the engine.

Replace any warning sign that is damaged or missing. If a warning sign is attached to a part of the engine that is replaced, install a new warning sign on the replacement part. Your Perkins dealer or your Perkins distributor can provide new warning signs.

904J-E36TA Industrial Open Power Unit (IOPU)

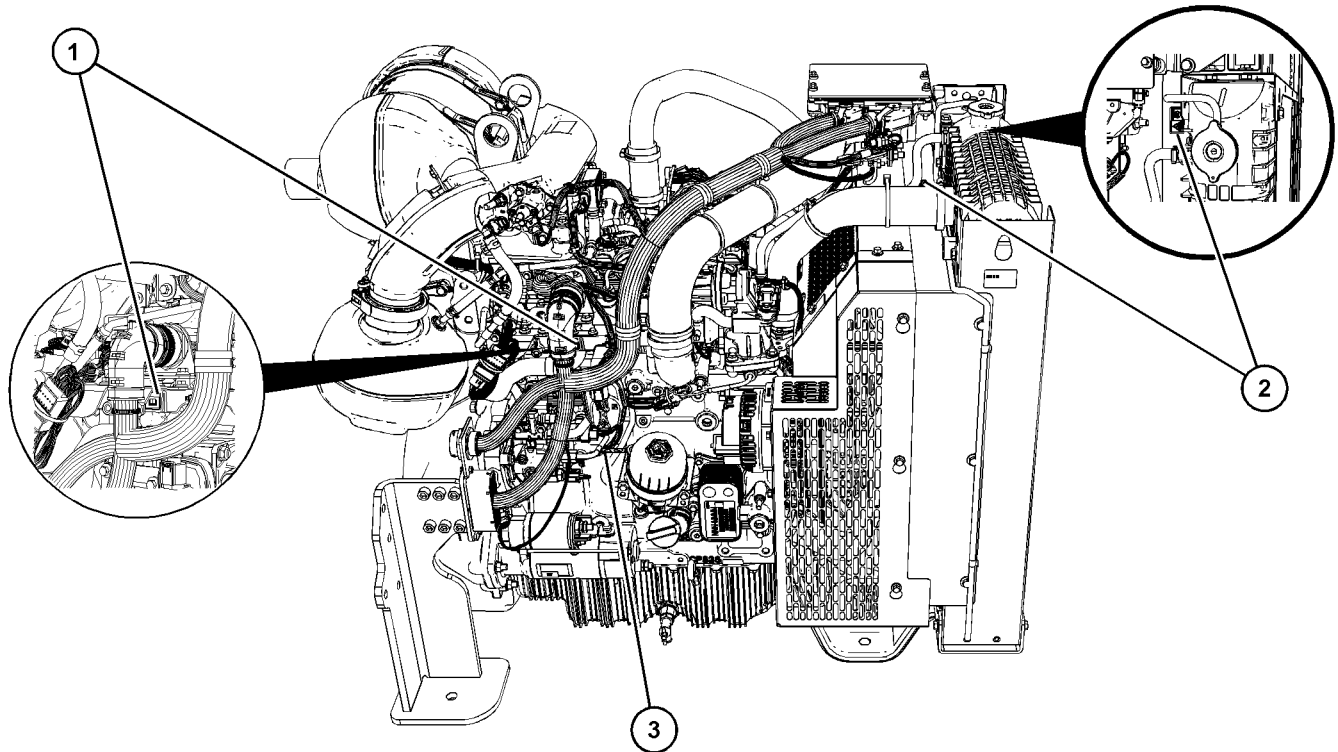

Illustration 10
Typical example of an IOPU

g06737415

904J-E36TA Electropak

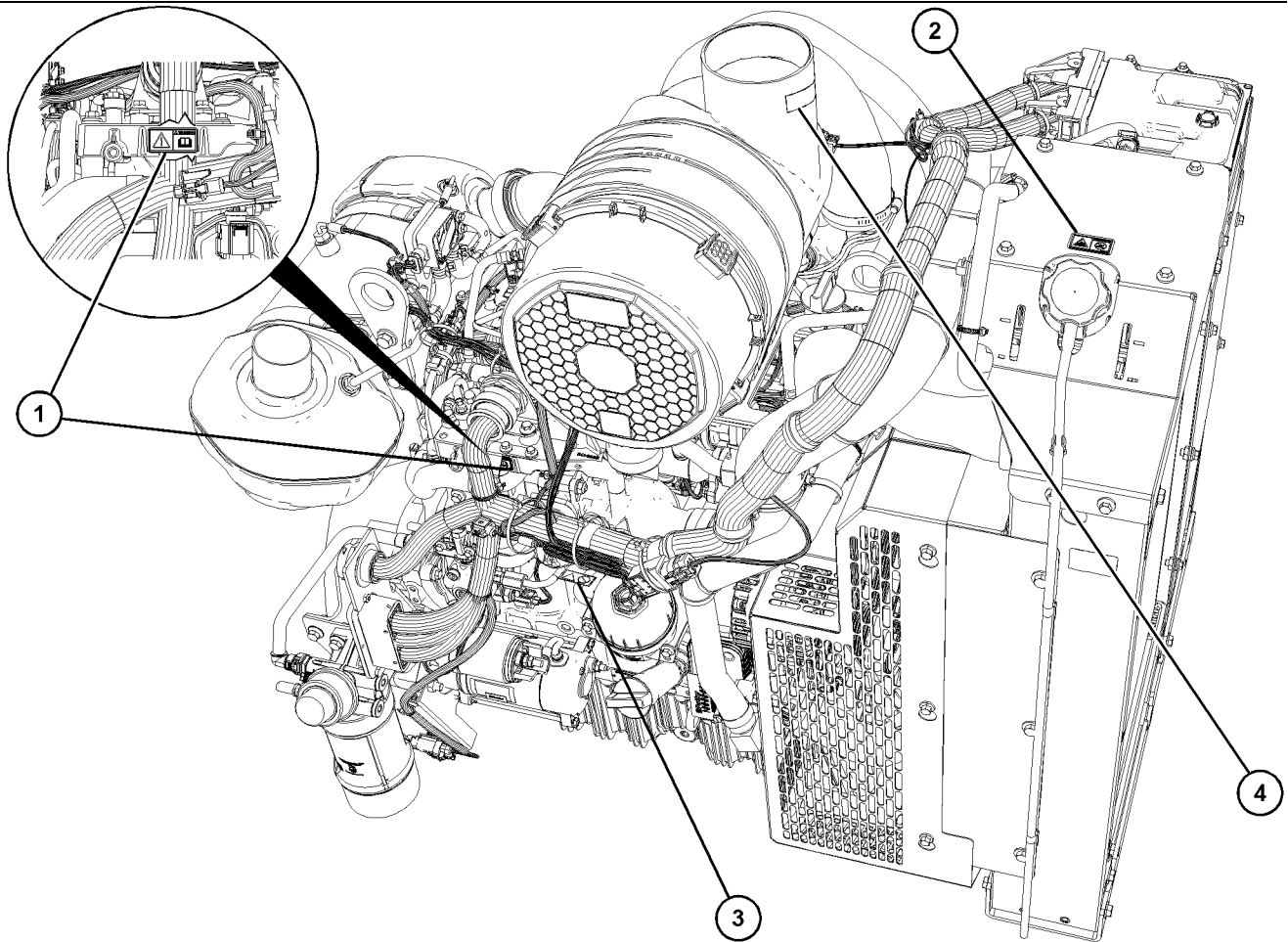

Illustration 11

Typical example of an Electropak

g07667807

Universal Warning 1

⚠ WARNING

Do not operate or work on this equipment unless you have read and understand the instructions and warnings in the Operation and Maintenance Manuals. Failure to follow the instructions or heed the warnings could result in serious injury or death.

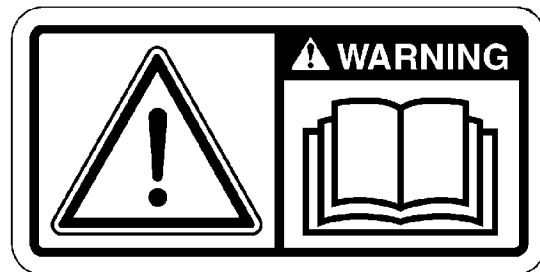

Illustration 12

Typical example

g01154807

The universal warning labels are installed in two positions. The labels are on each side of the engine.

Hot Fluid Under Pressure 2



Illustration 13

g01371640

WARNING

Pressurized system! Hot coolant can cause serious burns, injury or death. To open the cooling system filler cap, stop the engine and wait until the cooling system components are cool. Loosen the cooling system pressure cap slowly in order to relieve the pressure. Read and understand the Operation and Maintenance Manual before performing any cooling system maintenance.

The hot fluids under pressure label is installed on the radiator cover next to the coolant filler cap.

Hand (High Pressure) 3

WARNING

Contact with high pressure fuel may cause fluid penetration and burn hazards. High pressure fuel spray may cause a fire hazard. Failure to follow these inspection, maintenance and service instructions may cause personal injury or death.



Illustration 14

g02382677

Typical example

The hand high-pressure label is on the high-pressure fuel line between pump and manifold, on the right side of the engine.

Ether Warning 4



Illustration 15

g01154809

Typical example

The ether warning label is installed on the air cleaner close to the intake. The location will depend on the application. In some applications, the ether label will be supplied loose for fitting by the engine installer.

i07676530

Additional Messages

There are several specific messages on this engine. The exact location of the messages and the description of the information are reviewed in this section. Become familiar with all messages.

Make sure that all the messages are legible. Clean the messages or replace the messages if the messages are not legible. Replace the illustrations if the illustrations are not legible. When cleaning the messages, use a cloth, water, and soap. Do not use solvent, gasoline, or other harsh chemicals to clean the messages. Solvents, gasoline, or harsh chemicals could loosen the adhesive that secures the messages. Loose adhesive will allow the messages to fall.

Replace any message that is damaged, or missing. If a message is attached to a part that is replaced, install a message on the replacement part. Replacement labels may be obtained from Perkins distributors.

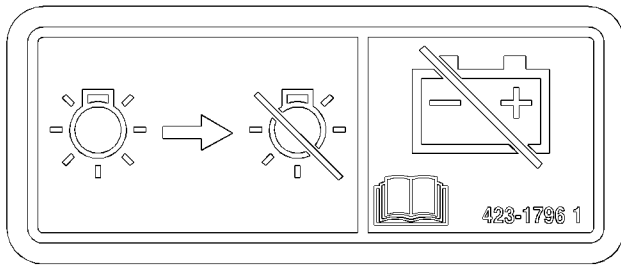

Illustration 16

g03422039

Purge notice message

This notice should be located next to the battery disconnect switch.

NOTICE

Do not turn the battery power disconnect switch off until indicator lamp has turned off. If the switch is turned off when the light is illuminated then the DEF system will not purge and DEF could freeze and cause damage to the pump and lines.

i08459738

General Hazard Information

Illustration 17

g00104545

Attach a “Do Not Operate” warning tag or a similar warning tag to the start switch or to the controls before the engine is serviced or before the engine is repaired. Attach the warning tags to the engine and to each operator control station. When appropriate, disconnect the starting controls.

Excessive idling of the engine in cold ambient temperatures could result in the breather freezing. The breather freezing can cause leaks & component failure, which can be harmful to the engine.

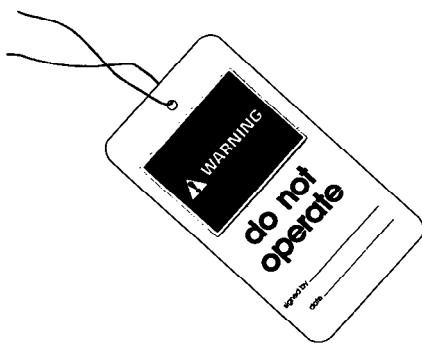
Do not allow unauthorized personnel on the engine, or around the engine when the engine is being serviced.

- Tampering with the engine installation or tampering with the OEM supplied wiring can be dangerous. Personal injury, death and/or engine damage could result.
- Vent the engine exhaust to the outside when the engine is operated in an enclosed area.
- If the engine is not running, do not release the secondary brake or the parking brake systems unless the vehicle is blocked or unless the vehicle is restrained.
- Wear a hard hat, protective glasses, and other protective equipment, as required.
- When working around an engine, the engine must not be in operation. You may only be near a running engine to carry out maintenance procedures that require the engine to be in operation.
- Do not wear loose clothing or jewelry that can snag on controls or on other parts of the engine.
- Ensure that all protective guards and all covers are secured in place on the engine.
- Never put maintenance fluids into glass containers. Glass containers can break.
- Use all cleaning solutions with care.
- Report all necessary repairs.

Unless other instructions are provided, perform the maintenance under the following conditions:

- The engine is stopped. Ensure that the engine cannot be started.
- The protective locks or the controls are in the applied position.
- Engage the secondary brakes or parking brakes.
- Block the vehicle or restrain the vehicle before maintenance or repairs are performed.
- Disconnect the batteries when maintenance is performed or when the electrical system is serviced. Disconnect the battery ground leads. Tape the leads to help prevent sparks. If equipped, allow the diesel exhaust fluid to be purged before disconnecting the battery.

Safety Section
General Hazard Information

- If equipped, disconnect the connectors for the unit injectors that are on the valve cover base. This action will help prevent personal injury from the high voltage to the unit injectors. Do not come in contact with the unit injector terminals while the engine is operating.
- Do not attempt any repairs or any adjustments to the engine while the engine is operating.
- Do not attempt any repairs that are not understood. Use the proper tools. Replace any equipment that is damaged or repair the equipment.
- For initial start-up of a new engine or for starting an engine that has been serviced, make provisions to stop the engine if an overspeed occurs. The stopping of the engine may be accomplished by shutting off the fuel supply and/or the air supply to the engine. Ensure that only the fuel supply line is shut off. Ensure that the fuel return line is open.
- Start the engine from the operators station (cab). Never short across the starting motor terminals or the batteries. This action could bypass the engine neutral start system and/or the electrical system could be damaged.

Engine exhaust contains products of combustion which may be harmful to your health. Always start the engine and operate the engine in a well-ventilated area. If the engine is in an enclosed area, vent the engine exhaust to the outside.

Cautiously remove the following parts. To help prevent spraying or splashing of pressurized fluids, hold a rag over the part that is being removed.

- Filler caps
- Grease fittings
- Pressure taps
- Breathers
- Drain plugs

Use caution when cover plates are removed. Gradually loosen, but do not remove the last two bolts or nuts that are at opposite ends of the cover plate or the device. Before removing the last two bolts or nuts, pry the cover loose to relieve any spring pressure or other pressure.

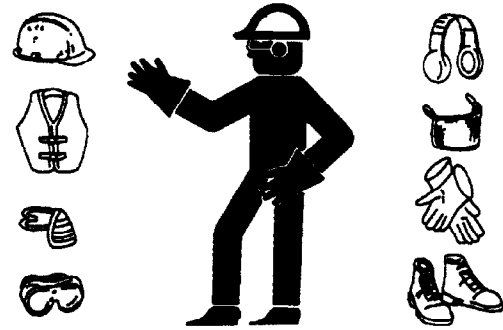

Illustration 18

g00702020

- Wear a hard hat, protective glasses, and other protective equipment, as required.
- Perkins recommend that you do not stand next to an exposed running engine unless it is necessary when carrying out daily checks or maintenance procedures. The appropriate Personal Protective Equipment (PPE) must be worn when standing next to an exposed running engine.
- Do not wear loose clothing or jewelry that can snag on controls or on other parts of the engine.
- Ensure that all protective guards and all covers are secured in place on the engine.
- Never put maintenance fluids into glass containers. Glass containers can break.
- Use all cleaning solutions with care.
- Report all necessary repairs.

Unless other instructions are provided, perform the maintenance under the following conditions:

- The engine is stopped. Ensure that the engine cannot be started.
- Disconnect the batteries when maintenance is performed or when the electrical system is serviced. Disconnect the battery ground leads. Tape the leads to help prevent sparks.
- Do not attempt any repairs that are not understood. Use the proper tools. Replace any equipment that is damaged or repair the equipment.

Pressurized Air and Water

Pressurized air and/or water can cause debris and/or hot water to be blown out. This action could result in personal injury.

When pressurized air and/or pressurized water is used for cleaning, wear protective clothing, protective shoes, and eye protection. Eye protection includes goggles or a protective face shield.

The maximum air pressure for cleaning purposes must be below 205 kPa (30 psi). The maximum water pressure for cleaning purposes must be below 275 kPa (40 psi).

Fluid Penetration

Pressure can be trapped in the hydraulic circuit long after the engine has been stopped. The pressure can cause hydraulic fluid or items such as pipe plugs to escape rapidly if the pressure is not relieved correctly.

Do not remove any hydraulic components or parts until pressure has been relieved or personal injury may occur. Do not disassemble any hydraulic components or parts until pressure has been relieved or personal injury may occur. Refer to the OEM information for any procedures that are required to relieve the hydraulic pressure.

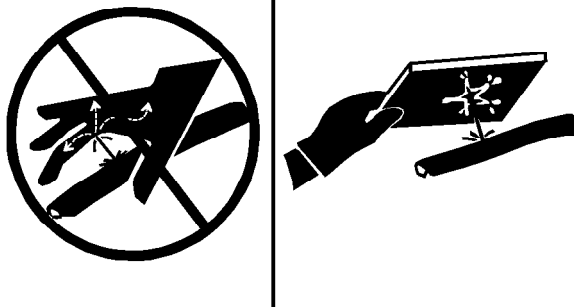

Illustration 19

g00687600

Always use a board or cardboard when you check for a leak. Leaking fluid that is under pressure can penetrate body tissue. Fluid penetration can cause serious injury and possible death. A pin hole leak can cause severe injury. If fluid is injected into your skin, you must get treatment immediately. Seek treatment from a doctor that is familiar with this type of injury.

Containing Fluid Spillage

Care must be taken to ensure that fluids are contained during performance of inspection, maintenance, testing, adjusting, and repair of the product. Be prepared to collect the fluid with suitable containers before opening any compartment or disassembling any component containing fluids.

Dispose of all fluids according to local regulations and mandates.

Static Electricity Hazard when Fueling with Ultra-low Sulfur Diesel Fuel

The removal of sulfur and other compounds in ultra-low sulfur diesel fuel (ULSD fuel) decreases the conductivity of ULSD and increases the ability of ULSD to store static charge. Refineries may have treated the fuel with a static dissipating additive. Many factors can reduce the effectiveness of the additive over time. Static charges can build up in ULSD fuel while the fuel is flowing through fuel delivery systems. Static electricity discharge when combustible vapors are present could result in a fire or explosion. Ensure that the entire system used to refuel your machine (fuel supply tank, transfer pump, transfer hose, nozzle, and others) is properly grounded and bonded. Consult with your fuel or fuel system supplier to ensure that the delivery system complies with fueling standards for proper grounding and bonding.

⚠ WARNING

Avoid static electricity risk when fueling. Ultra-low sulfur diesel fuel (ULSD fuel) poses a greater static ignition hazard than earlier diesel formulations with a higher sulfur contents. Avoid death or serious injury from fire or explosion. Consult with your fuel or fuel system supplier to ensure the delivery system is in compliance with fueling standards for proper grounding and bonding practices.

Inhalation

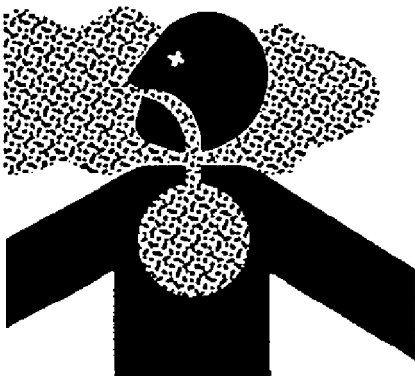

Illustration 20

g00702022

Exhaust

Use caution. Exhaust fumes can be hazardous to health. If you operate the equipment in an enclosed area, adequate ventilation is necessary.

Hexavalent Chromium

Perkins equipment and replacement parts comply with applicable regulations and requirements where originally sold. Perkins recommends the use of only genuine Perkins replacement parts.

Hexavalent chromium has occasionally been detected on exhaust and heat shield systems on Perkins engines. Although laboratory testing is the only accurate way to know if hexavalent chromium is, in fact, present, the presence of a yellow deposit in areas of high heat (for example, exhaust system components or exhaust insulation) may be an indication of the presence of hexavalent chromium.

Use caution if you suspect the presence of hexavalent chromium. Avoid skin contact when handling items that you suspect may contain hexavalent chromium, and avoid inhalation of any dust in the suspect area. Inhalation of, or skin contact with, hexavalent chromium dust may be hazardous to your health.

If such yellow deposits are found on the engine, engine component parts, or associated equipment or packages, Perkins recommends following local health and safety regulations and guidelines, utilizing good hygiene, and adhering to safe work practices when handling the equipment or parts. Perkins also recommends the following:

- Wear appropriate Personal Protective Equipment (PPE)
- Wash your hands and face with soap and water prior to eating, drinking, or smoking, and also during rest room breaks, to prevent ingestion of any yellow powder
- Never use compressed air for cleaning areas suspected of containing hexavalent chromium
- Avoid brushing, grinding, or cutting materials suspected of containing hexavalent chromium
- Obey environmental regulations for the disposal of all materials that may contain or have come into contact with hexavalent chromium
- Stay away from areas that might have hexavalent chromium particles in the air.

Asbestos Information

Perkins equipment and replacement parts that are shipped from Perkins engine company limited are asbestos free. Perkins recommends the use of only genuine Perkins replacement parts. Use the following guidelines when you handle any replacement parts that contain asbestos or when you handle asbestos debris.

Use caution. Avoid inhaling dust that might be generated when you handle components that contain asbestos fibers. Inhaling this dust can be hazardous to your health. The components that may contain asbestos fibers are brake pads, brake bands, lining material, clutch plates, and some gaskets. The asbestos that is used in these components is usually bound in a resin or sealed in some way. Normal handling is not hazardous unless airborne dust that contains asbestos is generated.

If dust that may contain asbestos is present, there are several guidelines that should be followed:

- Never use compressed air for cleaning.
- Avoid brushing materials that contain asbestos.
- Avoid grinding materials that contain asbestos.
- Use a wet method to clean up asbestos materials.
- A vacuum cleaner that is equipped with a high efficiency particulate air filter (HEPA) can also be used.

- Use exhaust ventilation on permanent machining jobs.
- Wear an approved respirator if there is no other way to control the dust.
- Comply with applicable rules and regulations for the work place. In the United States, use Occupational Safety and Health Administration (OSHA) requirements. These OSHA requirements can be found in "29 CFR 1910.1001".
- Obey environmental regulations for the disposal of asbestos.
- Stay away from areas that might have asbestos particles in the air.

Dispose of Waste Properly

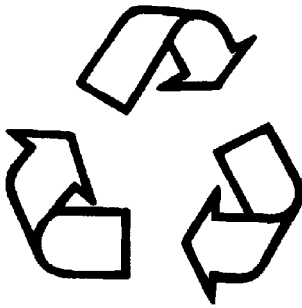

Illustration 21

g00706404

Improperly disposing of waste can threaten the environment. Potentially harmful fluids should be disposed of in accordance with local regulations.

Always use leakproof containers when you drain fluids. Do not pour waste onto the ground, down a drain, or into any source of water.

Diesel Exhaust Fluid

WARNING

DEF is an aqueous solution of urea which can re-lease ammonia vapors. Always wear the appropriate Personal Protective Equipment (PPE) that is noted on a material safety data sheet (MSDS) for Diesel Exhaust Fluid (DEF).

- Do not inhale ammonia vapor or mist
- Do not eat, drink, or smoke in presence of DEF
- Avoid DEF contact with eyes, skin, and clothing
- Wash thoroughly after handling DEF

Always follow the directions for first aid that are noted on a material safety data sheet (MSDS) for Diesel Exhaust Fluid (DEF).

DEF is not expected to produce significant adverse health effects when the recommended instructions for use are followed.

- Draining DEF must be carried out in a well-ventilated area.
- Do not allow the DEF to be spilled onto hot surfaces.

i07277507

Burn Prevention

Do not touch any part of an operating engine system. The engine, the exhaust, and the engine aftertreatment system can exceed 650° C (1202° F) under normal operating conditions.

Allow the engine system to cool before any maintenance is performed. Relieve all pressure in the air system, hydraulic system, lubrication system, fuel system, and the cooling system before the related items are disconnected.

WARNING

Contact with high pressure fuel may cause fluid penetration and burn hazards. High pressure fuel spray may cause a fire hazard. Failure to follow these inspection, maintenance and service instructions may cause personal injury or death.

After the engine has stopped, wait for 10 minutes to allow the fuel pressure to be purged from the high-pressure fuel lines before any service or repair is performed on the engine fuel lines. The 10 minute wait will also allow static charge to dissipate from the low-pressure fuel system.

Allow the pressure to be purged in the air system, in the hydraulic system, in the lubrication system, or in the cooling system before any lines, fittings, or related items are disconnected.

Induction System

WARNING

Sulfuric Acid Burn Hazard may cause serious personal injury or death.

The exhaust gas cooler may contain a small amount of sulfuric acid. The use of fuel with sulfur levels greater than 15 ppm may increase the amount of sulfuric acid formed. The sulfuric acid may spill from the cooler during service of the engine. The sulfuric acid will burn the eyes, skin and clothing on contact. Always wear the appropriate personal protective equipment (PPE) that is noted on a material safety data sheet (MSDS) for sulfuric acid. Always follow the directions for first aid that are noted on a material safety data sheet (MSDS) for sulfuric acid.

Coolant

When the engine is at operating temperature, the engine coolant is hot. The coolant is also under pressure. The radiator and all lines to the heaters, aftertreatment system or to the engine contain hot coolant.

Any contact with hot coolant or with steam can cause severe burns. Allow cooling system components to cool before the cooling system is drained.

Check the coolant level after the engine has stopped and the engine has been allowed to cool.

Ensure that the filler cap is cool before removing the filler cap. The filler cap must be cool enough to touch with a bare hand. Remove the filler cap slowly to relieve pressure.

Cooling system conditioner contains alkali. Alkali can cause personal injury. Do not allow alkali to contact the skin, the eyes, or the mouth.

Oils

Skin may be irritated following repeated or prolonged exposure to mineral and synthetic base oils. Refer to your suppliers Material Safety Data Sheets for detailed information. Hot oil and lubricating components can cause personal injury. Do not allow hot oil to contact the skin. Appropriate personal protective equipment should be used.

Diesel Fuel

Diesel engines have high-pressure fuel systems and the fuel can reach temperatures of over 100° C (212° F). Ensure that the fuel has cooled before any service or repairs are performed.

Diesel may be irritating to the eyes, respiratory system, and skin. Prolonged exposure to diesel may cause various skin conditions. Appropriate personal protective equipment should be used. Refer to supplier Material safety Data sheets for detailed information.

Batteries

Electrolyte is an acid. Electrolyte can cause personal injury. Do not allow electrolyte to contact the skin or the eyes. Always wear protective glasses for servicing batteries. Wash hands after touching the batteries and connectors. Use of gloves is recommended.

Engine and Aftertreatment System

Do not touch any part of an operating engine or engine aftertreatment system. Allow the engine or the engine aftertreatment system to cool before any maintenance is performed on the engine or the engine aftertreatment system. Relieve all pressure in the appropriate system before any lines, fittings, or related items are disconnected.

Aftertreatment System and Diesel Exhaust Fluid

Diesel Exhaust Fluid (DEF) temperatures can reach 65° to 70°C (149.° to 126°F) during normal engine operation. Stop the engine. Wait for 15 minutes to allow the DEF system to be purged and the DEF to cool before service or repair is performed.

i07817010

Fire Prevention and Explosion Prevention



Illustration 22

g00704000

All fuels, most lubricants, and some coolant mixtures are flammable.

Flammable fluids that are leaking or spilled onto hot surfaces or onto electrical components can cause a fire. Fire may cause personal injury and property damage.

After the emergency stop button is operated, ensure that you allow 15 minutes, before the engine covers are removed.

Determine whether the engine will be operated in an environment that allows combustible gases to be drawn into the air inlet system. These gases could cause the engine to overspeed. Personal injury, property damage, or engine damage could result.

If the application involves the presence of combustible gases, consult your Perkins dealer and/or your Perkins distributor for additional information about suitable protection devices.

Remove all flammable combustible materials or conductive materials such as fuel, oil, and debris from the engine. Do not allow any flammable combustible materials or conductive materials to accumulate on the engine.

Store fuels and lubricants in correctly marked containers away from unauthorized persons. Store oily rags and any flammable materials in protective containers. Do not smoke in areas that are used for storing flammable materials.

Do not expose the engine to any flame.

Exhaust shields (if equipped) protect hot exhaust components from oil or fuel spray if there was a line, a tube, or a seal failure. Exhaust shields must be installed correctly.

Do not weld on lines or tanks that contain flammable fluids. Do not flame cut lines or tanks that contain flammable fluid. Clean any such lines or tanks thoroughly with a nonflammable solvent prior to welding or flame cutting.

Wiring must be kept in good condition. Ensure that all electrical wires are correctly installed and securely attached. Check all electrical wires daily. Repair any wires that are loose or frayed before you operate the engine. Clean all electrical connections and tighten all electrical connections.

Eliminate all wiring that is unattached or unnecessary. Do not use any wires or cables that are smaller than the recommended gauge. Do not bypass any fuses and/or circuit breakers.

Arcing or sparking could cause a fire. Secure connections, recommended wiring, and correctly maintained battery cables will help to prevent arcing or sparking.

WARNING

Contact with high pressure fuel may cause fluid penetration and burn hazards. High pressure fuel spray may cause a fire hazard. Failure to follow these inspection, maintenance and service instructions may cause personal injury or death.

After the engine has stopped, you must wait for 10 minutes to allow the fuel pressure to be purged from the high-pressure fuel lines before any service or repair is performed on the engine fuel lines. The 10 minute wait will also allow static charge to dissipate from the low-pressure fuel system.

Ensure that the engine is stopped. Inspect all lines and hoses for wear or for deterioration. Ensure that the hoses are correctly routed. The lines and hoses must have adequate support and secure clamps. If any fuel lines or fuel hoses become kinked, the fuel line or fuel hose must be replaced. Refer to the Disassembly and Assembly manual for more information.

Oil filters and fuel filters must be correctly installed. The filter housings must be tightened to the correct torque. Refer to the Disassembly and Assembly manual for more information.



Illustration 23

g00704059

Use caution when you are refueling an engine. Do not smoke while you are refueling an engine. Do not refuel an engine near open flames or sparks. Always stop the engine before refueling.

Avoid static electricity risk when fueling. Ultra-low Sulfur Diesel fuel (ULSD fuel) poses a greater static ignition hazard than earlier diesel formulations with a higher sulfur content. Avoid death or serious injury from fire or explosion. Consult your fuel or fuel system supplier to ensure that the delivery system is in compliance with fueling standards for proper grounding and bonding practices.



Illustration 24

g00704135

Gases from a battery can explode. Keep any open flames or sparks away from the top of a battery. Do not smoke in battery charging areas.

Never check the battery charge by placing a metal object across the terminal posts. Use a voltmeter or a hydrometer.

Incorrect jumper cable connections can cause an explosion that can result in injury. Refer to the Operation Section of this manual for specific instructions.

Do not charge a frozen battery. A frozen battery may cause an explosion.

The batteries must be kept clean. The covers (if equipped) must be kept on the cells. Use the recommended cables, connections, and battery box covers when the engine is operated.

Fire Extinguisher

Make sure that a fire extinguisher is available. Be familiar with the operation of the fire extinguisher. Inspect the fire extinguisher and service the fire extinguisher regularly. Obey the recommendations on the instruction plate.

Ether

WARNING

Do not use aerosol types of starting aids such as ether. Such use could result in an explosion and personal injury.

Ether is flammable and poisonous.

Do not smoke while you are replacing an ether cylinder.

Do not store ether cylinders in living areas or in the engine compartment. Do not store ether cylinders in direct sunlight or in temperatures above 49° C (120° F). Keep ether cylinders away from open flames or sparks.

Lines, Tubes, and Hoses

Do not bend high-pressure lines. Do not strike high-pressure lines. Do not install any lines that are damaged.

Leaks can cause fires. Consult your Perkins dealer or your Perkins distributor for replacement parts.

Replace the parts if any of the following conditions are present:

- High-pressure fuel line or lines are removed.
- End fittings are damaged or leaking.
- Outer coverings are chafed or cut.
- Wires are exposed.
- Outer coverings are ballooning.
- Flexible parts of the hoses are kinked.
- Outer covers have embedded armoring.
- End fittings are displaced.

Make sure that all clamps, guards, and heat shields are installed correctly. During engine operation, correct installation will help to prevent vibration, rubbing against other parts, and excessive heat.

i02143194

Crushing Prevention and Cutting Prevention

Support the component correctly when work beneath the component is performed.

Unless other maintenance instructions are provided, never attempt adjustments while the engine is running.

Stay clear of all rotating parts and of all moving parts. Leave the guards in place until maintenance is performed. After the maintenance is performed, reinstall the guards.

Keep objects away from moving fan blades. The fan blades will throw objects or cut objects.

When objects are struck, wear protective glasses in order to avoid injury to the eyes.

Chips or other debris may fly off objects when objects are struck. Before objects are struck, ensure that no one will be injured by flying debris.

i05768982

Mounting and Dismounting

Do not climb on the engine or the engine aftertreatment system. The engine and aftertreatment system have not been designed with mounting or dismounting locations.

Refer to the OEM for the location of foot and hand holds for your specific application.

i07366423

High Pressure Fuel Lines

WARNING

Contact with high pressure fuel may cause fluid penetration and burn hazards. High pressure fuel spray may cause a fire hazard. Failure to follow these inspection, maintenance and service instructions may cause personal injury or death.

Safety Section
High Pressure Fuel Lines

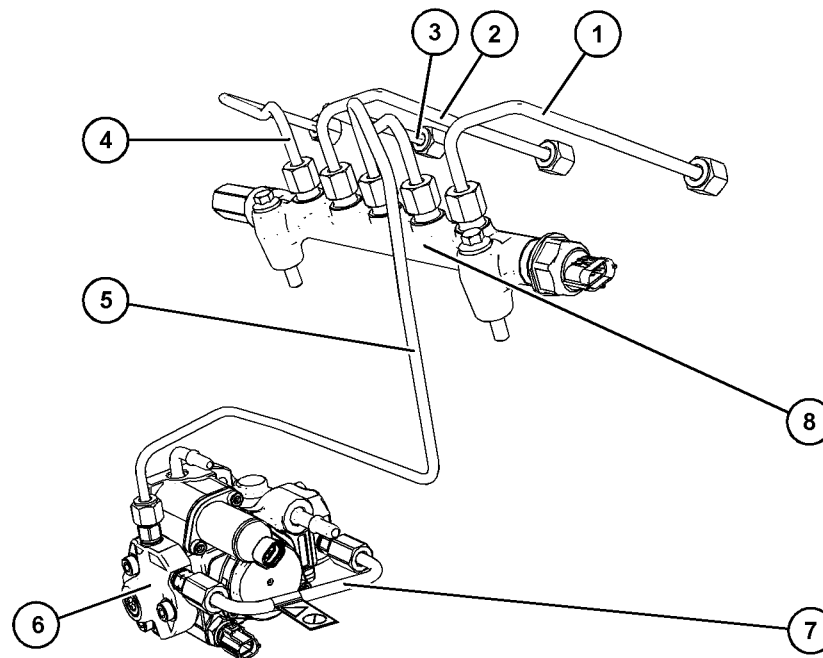

Illustration 25

g06334696

(1) High-pressure line
(2) High-pressure line
(3) High-pressure line

(4) High-pressure line
(5) Fuel transfer line that is high pressure
(6) High-pressure pump

(7) High-pressure line
(8) High-pressure fuel manifold (rail)

The high-pressure fuel lines are the fuel lines that are between the high-pressure fuel pump and the high-pressure fuel manifold and the fuel lines that are between the fuel manifold and electronic unit injectors. These fuel lines are different from fuel lines on other fuel systems.

The fuel lines are different because of the following items:

- The high-pressure fuel lines are constantly charged with high pressure.
- The internal pressures of the high-pressure fuel lines are higher than other types of fuel system.
- The high-pressure fuel lines are formed to shape and then strengthened by a special process.

Do not step on the high-pressure fuel lines. Do not deflect the high-pressure fuel lines. Do not bend or strike the high-pressure fuel lines. Deformation or damage of the high-pressure fuel lines may cause a point of weakness and potential failure.

Do not check the high-pressure fuel lines with the engine or the starting motor in operation. After the engine has stopped, you must wait for 10 minutes to allow the fuel pressure to be purged from the high-pressure fuel lines before any service or repair is performed on the engine fuel lines. The 10 minute wait will also allow static charge to dissipate from the low-pressure fuel system.

Do not loosen the high-pressure fuel lines to remove air from the fuel system. This procedure is not required.

Visually inspect the high-pressure fuel lines before the engine is started. This inspection should be each day.

If you inspect the engine in operation, always use the proper inspection procedure to avoid a fluid penetration hazard. Refer to Operation and Maintenance Manual, "General hazard Information".

- Inspect the high-pressure fuel lines for damage, deformation, a nick, a cut, a crease, or a dent.

- Do not operate the engine with a fuel leak. If there is a leak, do not tighten the connection, to stop the leak. The connection must only be tightened to the recommended torque. Refer to Disassembly and Assembly, “Fuel injection lines - Remove and Fuel injection lines - Install”.
- If the high-pressure fuel lines are torqued correctly and the high-pressure fuel lines are leaking, the high-pressure fuel lines must be replaced.
- Ensure that all clips on the high-pressure fuel lines are in place. Do not operate the engine with clips that are damaged, missing, or loose.
- Do not attach any other item to the high-pressure fuel lines.
- Loosened high-pressure fuel lines must be replaced. Also removed high-pressure fuel lines must be replaced. Refer to Disassembly and assembly manual, “Fuel Injection Lines - Install”.

i07728672

Before Starting Engine

NOTICE

For initial start-up of a new or rebuilt engine, and for start-up of an engine that has been serviced, make provision to shut the engine off should an overspeed occur. This may be accomplished by shutting off the air and/or fuel supply to the engine.

WARNING

Engine exhaust contains products of combustion which may be harmful to your health. Always start and operate the engine in a well ventilated area and, if in an enclosed area, vent the exhaust to the outside.

Inspect the engine for potential hazards.

Do not start the engine or move any of the controls if there is a “DO NOT OPERATE” warning tag or similar warning tag attached to the start switch or to the controls.

Before starting the engine, ensure that no one is on, underneath, or close to the engine. Ensure that the area is free of personnel.

If equipped, ensure that the lighting system for the engine is suitable for the conditions. Ensure that all lights work properly, if equipped.

All protective guards and all protective covers must be installed if the engine must be started to perform service procedures. To help prevent an accident that is caused by parts in rotation, work around the parts carefully.

Do not bypass the automatic shutoff circuits. Do not disable the automatic shutoff circuits. The circuits are provided to help prevent personal injury. The circuits are also provided to help prevent engine damage.

Before starting the engine, ensure that the drive belt is securely in place. The coolant pump is operated by the drive belt.

See the Service Manual for repairs and for adjustments.

i09664847

Engine Starting

WARNING

Do not use aerosol types of starting aids such as ether. Such use could result in an explosion and personal injury.

If a warning tag is attached to the engine start switch, or to the controls DO NOT start the engine or move the controls. Consult with the person that attached the warning tag before the engine is started.

All protective guards and all protective covers must be installed if the engine must be started to perform service procedures. To help prevent an accident that is caused by parts in rotation, work around the parts carefully.

Start the engine from the operator's compartment or from the engine start switch.

Always start the engine according to the procedure described in the Operation and Maintenance Manual, “Engine Starting” topic in the Operation Section. Knowing the correct procedure will help to prevent major damage to the engine components. Knowing the procedure will also help to prevent personal injury.

To ensure that the jacket water heater (if equipped) and/or the lube oil heater (if equipped) is working correctly, check the water temperature gauge. Also, check the oil temperature gauge during the heater operation.

WARNING

Engine exhaust contains products of combustion which may be harmful to your health. Always start and operate the engine in a well ventilated area and, if in an enclosed area, vent the exhaust to the outside.

Note: The engine is equipped with a device for cold starting. If the engine will be operated in very cold conditions, an extra cold starting aid may be required. Normally, the engine will be equipped with the correct type of starting aid for the region of operation.

These engines are equipped with a glow plug starting aid in each cylinder which heats the intake air to improve starting. Some Perkins engines may have a cold starting system that is controlled by the ECM which allows a controlled flow of ether into the engine. The ECM will disconnect the glow plugs before the ether is introduced. This system would be installed at the factory.

i02234873

Engine Stopping

Stop the engine according to the procedure in the Operation and Maintenance Manual, "Engine Stopping (Operation Section)" in order to avoid overheating of the engine and accelerated wear of the engine components.

Use the Emergency Stop Button (if equipped) ONLY in an emergency situation. Do not use the Emergency Stop Button for normal engine stopping. After an emergency stop, DO NOT start the engine until the problem that caused the emergency stop has been corrected.

Stop the engine if an overspeed condition occurs during the initial start-up of a new engine or an engine that has been overhauled.

To stop an electronically controlled engine, cut the power to the engine and/or shutting off the air supply to the engine.

i08185951

Electrical System

Never disconnect any charging unit circuit or battery circuit cable from the battery when the charging unit is operating. A spark can cause the combustible gases that are produced by some batteries to ignite.

To help prevent sparks from igniting combustible gases that are produced by some batteries, the negative "-" cable should be connected last from the external power source to the primary position for grounding.

Check the electrical wires daily for wires that are loose or frayed. Tighten all loose electrical connections before the engine is started. Repair all frayed electrical wires before the engine is started. See the Operation and Maintenance Manual for specific starting instructions.

Grounding Practices

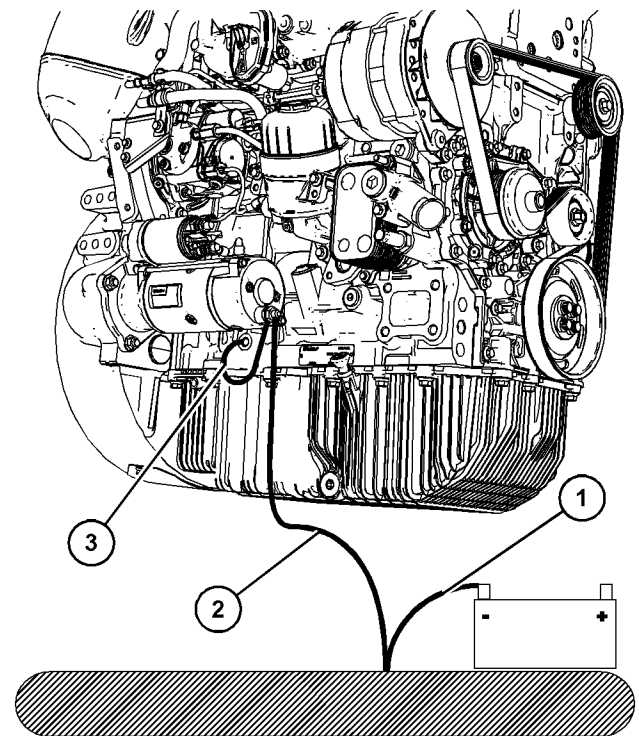

Illustration 26

g06296580

Typical example

- (1) Ground to battery
- (2) Ground to starting motor
- (3) Starting motor to engine block

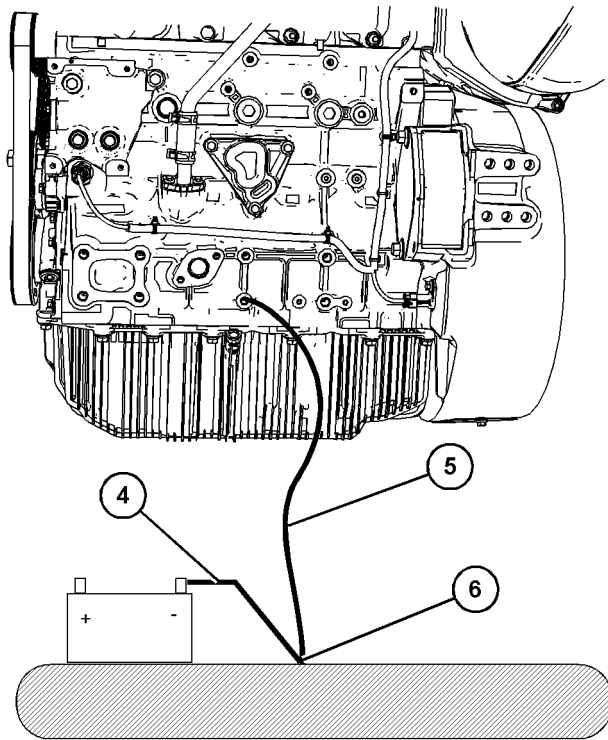

Illustration 27

g06296637

Typical example

- (4) Ground to the battery
- (5) Ground to the engine block
- (6) Primary position for grounding

NOTICE

For 904J-E36TA industrial engines, ensure that a 12 VDC or 24 VDC battery source is used to start the engine. For 904J-E28T and 904J-E28TA industrial engines, use a 12 VDC battery source to start the engine. Never attempt to start an engine from an external power source such as electric welding equipment, which has a voltage that is unsuitable for engine starting and will damage the electrical system.

Correct grounding for the engine electrical system is necessary for optimum engine performance and reliability. Incorrect grounding will result in uncontrolled electrical circuit paths and in unreliable electrical circuit paths.

Uncontrolled electrical circuit paths can result in damage to the crankshaft bearing journal surfaces and to aluminum components.

Engines that are installed without engine-to-frame ground straps can be damaged by electrical discharge.

To ensure that the engine and the engine electrical systems function correctly, an engine-to-frame ground strap with a direct path to the battery must be used. This path may be provided by way of a direct engine ground to the frame.

The connections for the grounds should be tight and free of corrosion. The engine alternator must be grounded to the negative “-” battery terminal. The wire used must be adequate to handle the full charging current of the alternator.

The power supply connection for the engine electronics should always be from the isolator to the battery. It is the decision of the OEM which polarity the isolator is connected to.

i07943840

Engine Electronics**⚠ WARNING**

Tampering with the electronic system installation or the OEM wiring installation can be dangerous and could result in personal injury or death and/or engine damage.

⚠ WARNING

Electrical Shock Hazard. The electronic unit injectors use DC voltage. The ECM sends this voltage to the electronic unit injectors. Do not come in contact with the harness connector for the electronic unit injectors while the engine is operating. Failure to follow this instruction could result in personal injury or death.

This engine has a comprehensive, programmable Engine Monitoring System. The Electronic Control Module (ECM) monitors the engine operating conditions. If any of the engine parameters extend outside an allowable range, the ECM will initiate an immediate action.

The following actions are available for engine monitoring control:

- Warning: A warning light could be illuminated or a sound warning could be activated (horn)
- Derate: The engine power could be reduced by 50 percent
- Shutdown: The engine could be shut down or only operate at low idle

The following monitored engine operating conditions and components can limit engine speed and/or the engine power:

- Engine Coolant Temperature

- Engine Oil Pressure
- Engine Speed
- Intake Manifold Air Temperature
- Intake Manifold Air Pressure
- Wastegate Actuator
- Supply Voltage to Sensors
- Fuel Temperature
- Fuel Pressure in Manifold (Rail)
- NOx Reduction System Temperature
- Engine Aftertreatment System

The Engine Monitoring package can vary for different engine models and different engine applications. However, the monitoring system and the engine monitoring control will be similar for all engines.

Note: Many of the engine control systems and display modules that are available for Perkins engines will work in unison with the Engine Monitoring System. Together, the two controls will provide the engine monitoring function for the specific engine application. Refer to the Troubleshooting for more information on the Engine Monitoring System.

Product Information Section

General Information

i07943842

Model View Illustrations

The following model views show typical features of the engine. Due to individual applications, your engine may appear different from the illustrations.

904J-E36TA Industrial Engine Views

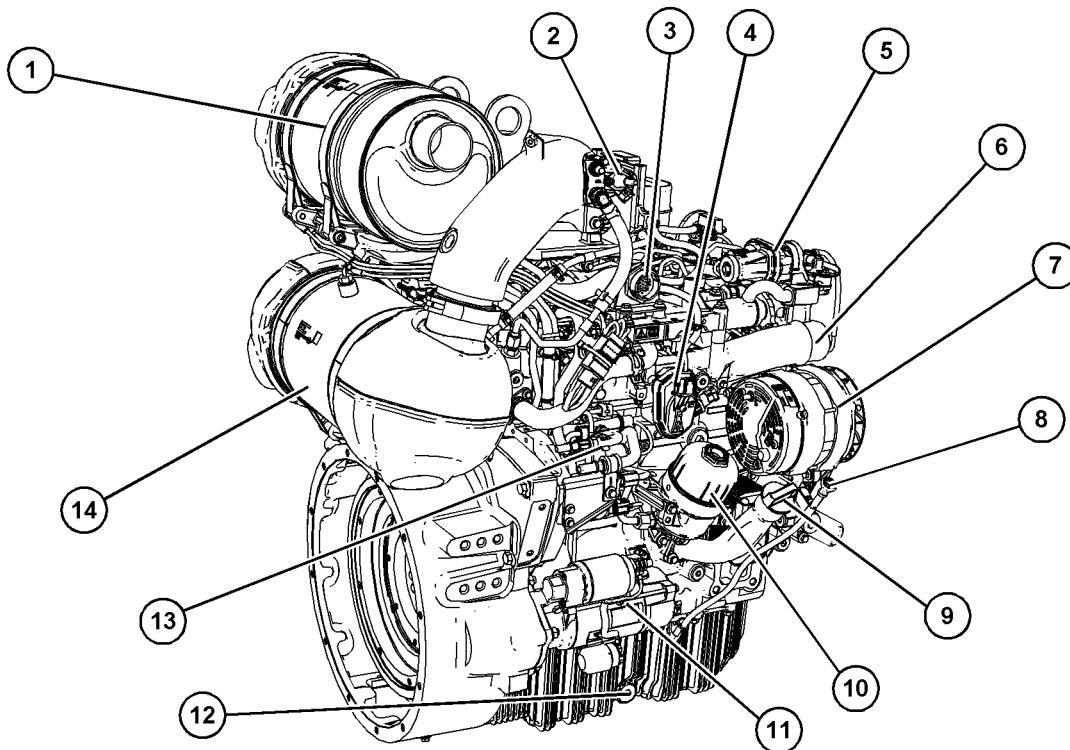

Illustration 28

g06297496

Typical example

- | | | |
|---|---------------------------------------|--------------------------------------|
| (1) Selective Catalytic Reduction (SCR) | (6) Air intake from air charge cooler | (11) Starting motor |
| (2) Diesel Exhaust Fluid (DEF) injector | (7) Alternator | (12) Oil drain plug |
| (3) Engine harness interface | (8) Oil gauge (Dipstick) | (13) High-pressure fuel pump |
| (4) Throttle control valve | (9) Oil filler (lower) | (14) Diesel Particulate Filter (DPF) |
| (5) NOx Reduction System (NRS) valve | (10) Oil filter assembly | |

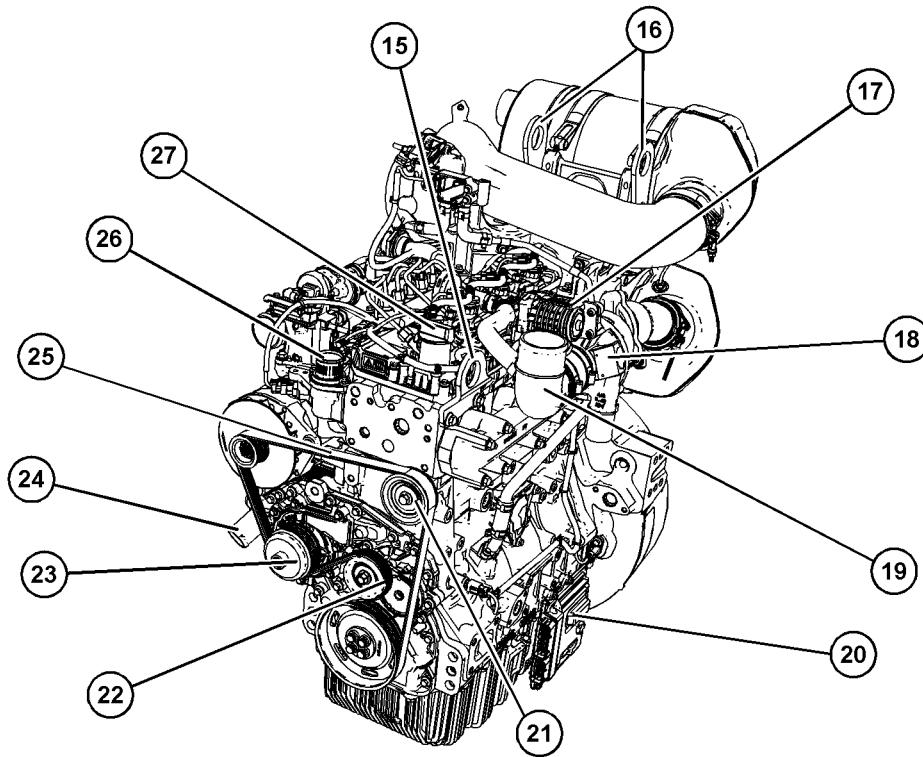

Illustration 29

g06297569

Typical example

- | | | |
|----------------------------------|---|---------------------|
| (15) Front lifting eye | (20) Electronic Control Module (ECM),
location for transportation only | (24) Coolant intake |
| (16) Rear lifting eyes | (21) Idler for drive belt | (25) Drive belt |
| (17) Actuator for turbocharger | (22) Adjuster for drive belt | (26) Coolant outlet |
| (18) Turbocharger | (23) Coolant pump pulley | (27) Top oil filler |
| (19) Air intake from air cleaner | | |

904J-E28T and 904J-E28TA Industrial Engine Views

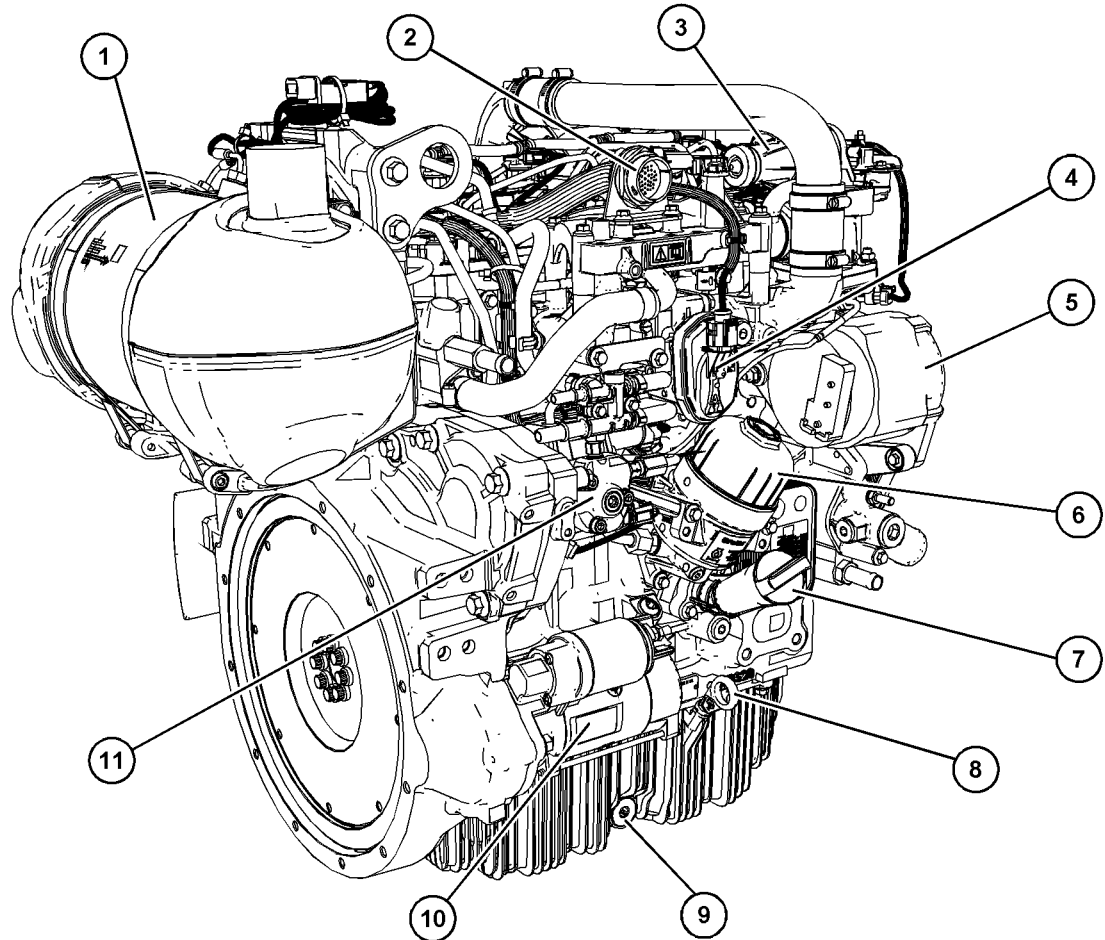

Illustration 30

g06481332

Typical example

- | | | |
|--|----------------------------|------------------------------|
| (1) Diesel Particulate Filter (DPF) and Diesel Oxidation Catalyst (DOC) combined | (4) Throttle control valve | (8) Oil gauge (Dipstick) |
| (2) Engine harness interface | (5) Alternator | (9) Oil drain plug |
| (3) NOx Reduction System (NRS) valve | (6) Oil filter assembly | (10) Starting motor |
| | (7) Oil filler (lower) | (11) High-pressure fuel pump |

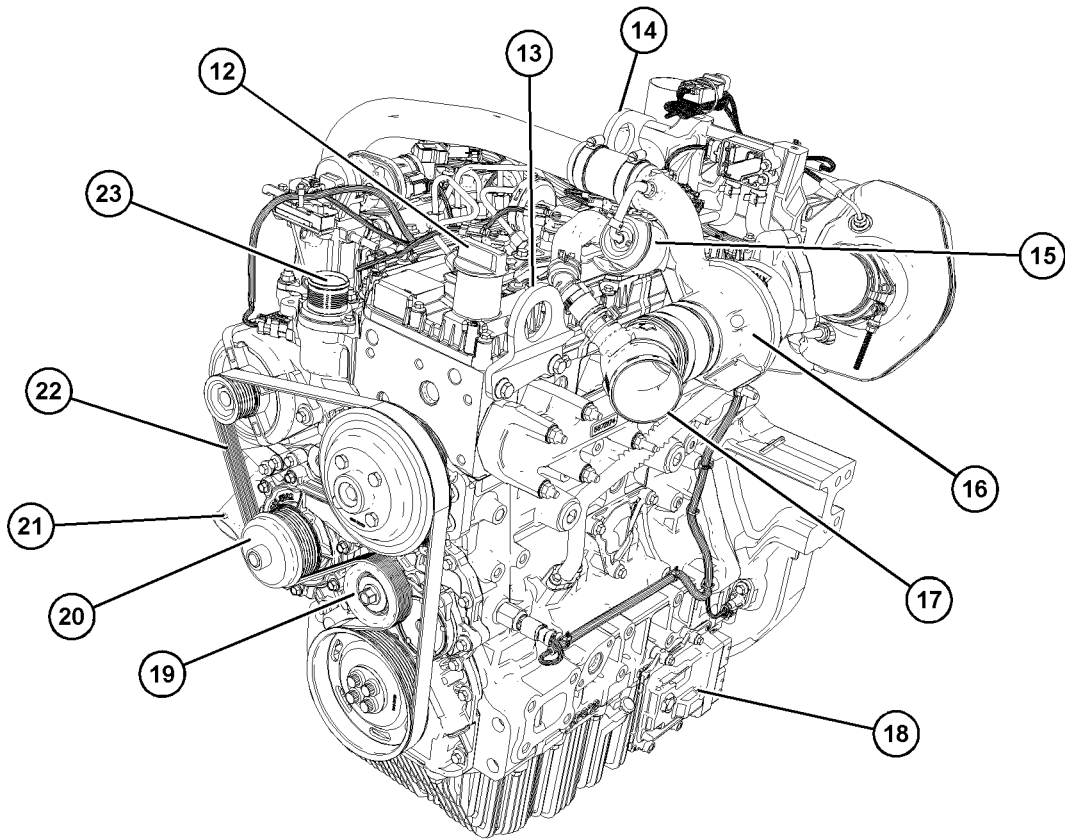

Illustration 31

g06481335

Typical example

(12) Oil filler (upper)
 (13) Front lifting eye
 (14) Rear lifting eyes
 (15) Actuator for turbocharger
 (16) Turbocharger

(17) Air intake from air cleaner
 (18) Electronic Control Module (ECM),
 location for transportation only
 (19) Adjuster for drive belt
 (20) Coolant pump pulley

(21) Coolant intake
 (22) Drive belt
 (23) Coolant outlet

Loose or Off Engine Components

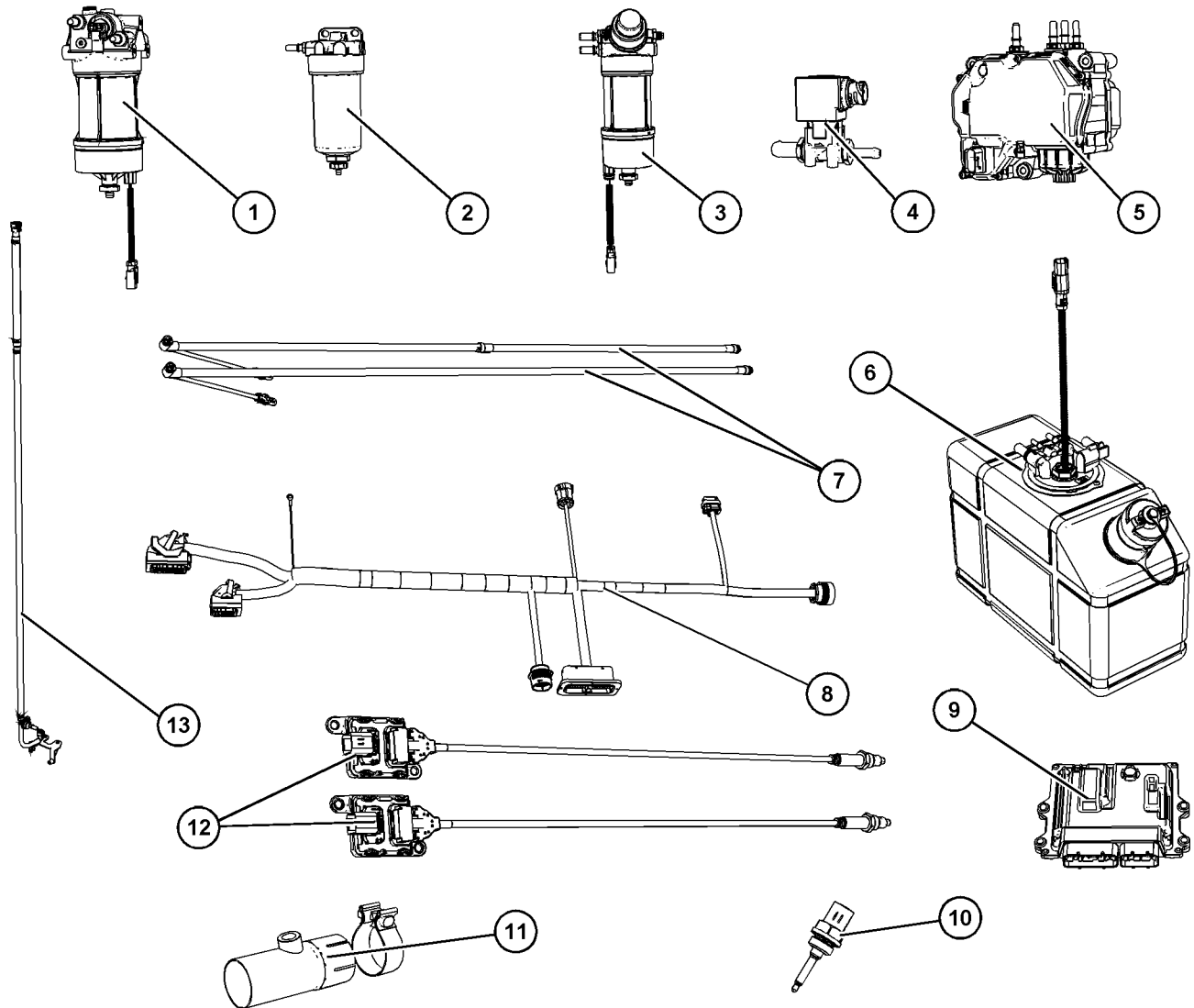

Illustration 32

g06297651

Typical example

- | | | |
|--|---|---|
| <ul style="list-style-type: none"> (1) Primary fuel filter, combined with electric fuel priming pump and Water-In-Fuel (WIF) sensor (2) If equipped, secondary fuel filter (3) Primary fuel filter, combined with manual fuel priming pump and Water-In-Fuel (WIF) sensor | <ul style="list-style-type: none"> (4) Coolant diverter valve (5) Diesel Exhaust Fluid (DEF) pump with DEF pump filter (6) DEF tank with DEF header installed (7) DEF heated lines (8) Link harness (9) Electric control module | <ul style="list-style-type: none"> (10) Inlet temperature sensor (11) Exhaust assembly (12) NOx sensors (13) Low-pressure fuel line |
|--|---|---|

i08023077

Model View Illustrations

The following model views show typical features of the engine. Due to individual applications, your engine may appear different from the illustrations.

904J-E36TA Industrial Engine Views

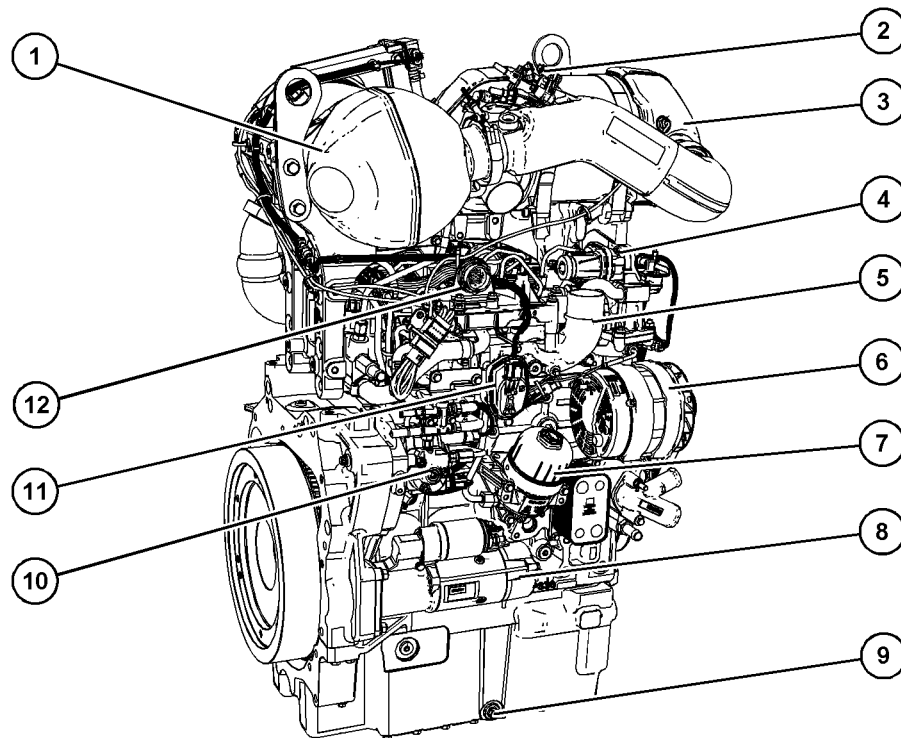

Illustration 33

g06511376

Typical example

- | | | |
|---|---------------------------------------|-------------------------------|
| (1) Selective Catalytic Reduction (SCR) | (5) Air intake from air charge cooler | (9) Oil drain plug (1 of 2) |
| (2) Diesel Exhaust Fluid (DEF) injector | (6) Alternator | (10) High-pressure fuel pump |
| (3) Diesel Particulate Filter (DPF) | (7) Oil filter assembly | (11) Throttle control valve |
| (4) NOx Reduction System (NRS) valve | (8) Starting motor | (12) Engine harness interface |

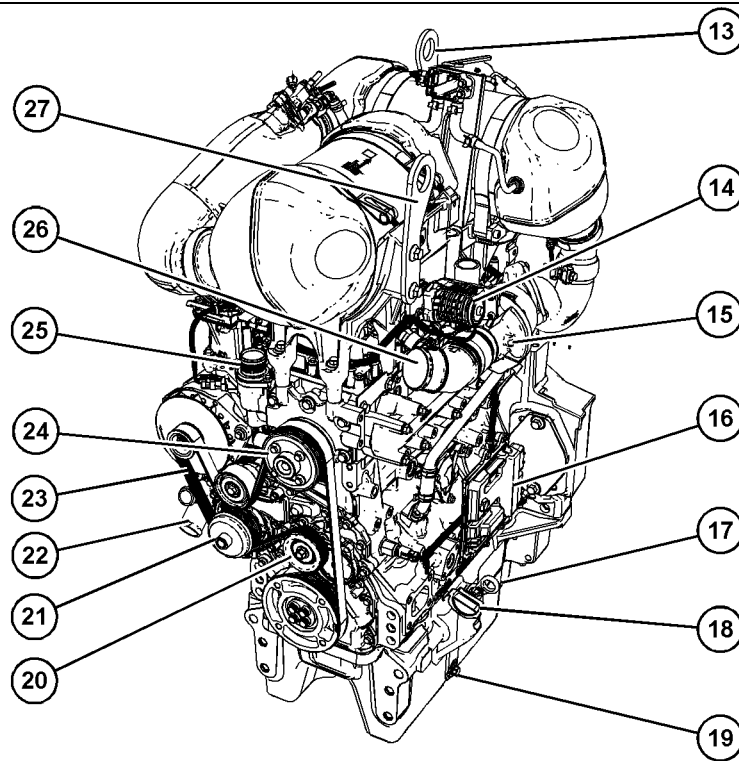

Illustration 34

g06511390

Typical example

- | | | |
|---|--|----------------------------------|
| (13) Rear lifting eyes | (18) Oil filler | (24) Fan pulley |
| (14) Actuator for turbocharger | (19) Oil drain plug (2 of 2) | (25) Coolant outlet |
| (15) Turbocharger | (20) Automatic adjuster for drive belt | (26) Air intake from air cleaner |
| (16) Electronic Control Module (ECM),
location for transportation only | (21) Coolant pump pulley | (27) Front lifting eye |
| (17) Oil gauge (Dipstick) | (22) Coolant intake | |
| | (23) Drive belt | |

Loose or Off Engine Components

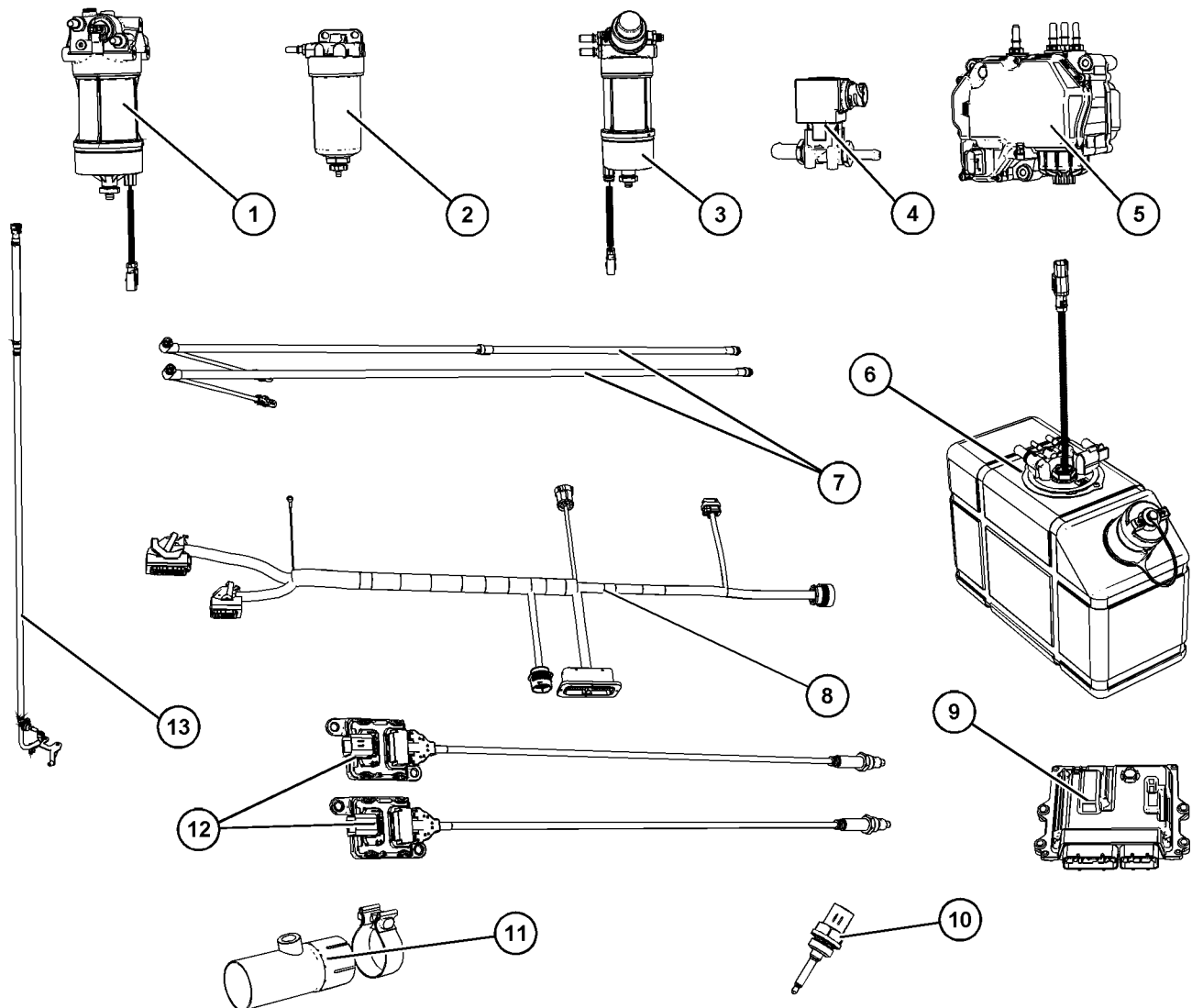

Illustration 35

g06297651

Typical example

- | | | |
|--|--|-------------------------------|
| (1) Primary fuel filter, combined with electric fuel priming pump and Water-In-Fuel (WIF) sensor | (4) Coolant diverter valve | (10) Inlet temperature sensor |
| (2) If equipped, secondary fuel filter | (5) Diesel Exhaust Fluid (DEF) pump with DEF pump filter | (11) Exhaust assembly |
| (3) Primary fuel filter, combined with manual fuel priming pump and Water-In-Fuel (WIF) sensor | (6) DEF tank with DEF header installed | (12) NOx sensors |
| | (7) DEF heated lines | (13) Low-pressure fuel line |
| | (8) Link harness | |
| | (9) Electric control module | |

i09674823

Model View Illustrations

The following model views show typical features of the engine. Due to individual applications, your engine may appear different from the illustrations.

904J-E36TA Industrial Open Power Unit (IOPU)

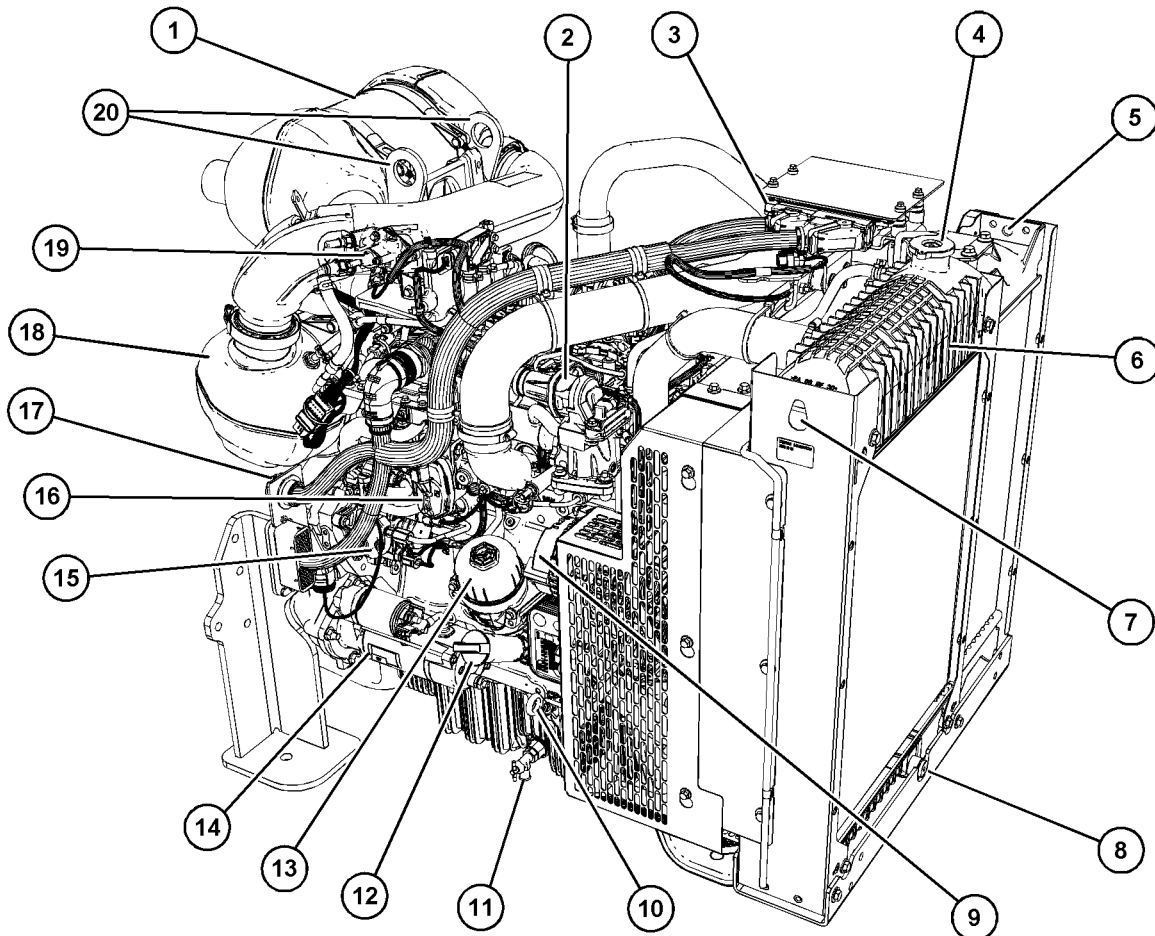

Illustration 36

g06737708

Typical example

- | | | |
|---|---------------------------|--|
| (1) Selective Catalytic Reduction (SCR) | (8) Radiator drain plug | (15) High-pressure fuel pump |
| (2) NOx Reduction System (NRS) valve | (9) Alternator | (16) Throttle control valve |
| (3) Electronic Control Module (ECM) | (10) Oil gauge (Dipstick) | (17) Engine harness interface |
| (4) Radiator filler cap | (11) Oil drain tap | (18) Diesel Particulate Filter (DPF) |
| (5) Radiator lifting point (1 of 2) | (12) Lower Oil filler | (19) Diesel Exhaust Fluid (DEF) injector |
| (6) Radiator | (13) Oil filter assembly | (20) Engine Rear lifting eyes |
| (7) Radiator lifting point (2 of 2) | (14) Starting motor | |

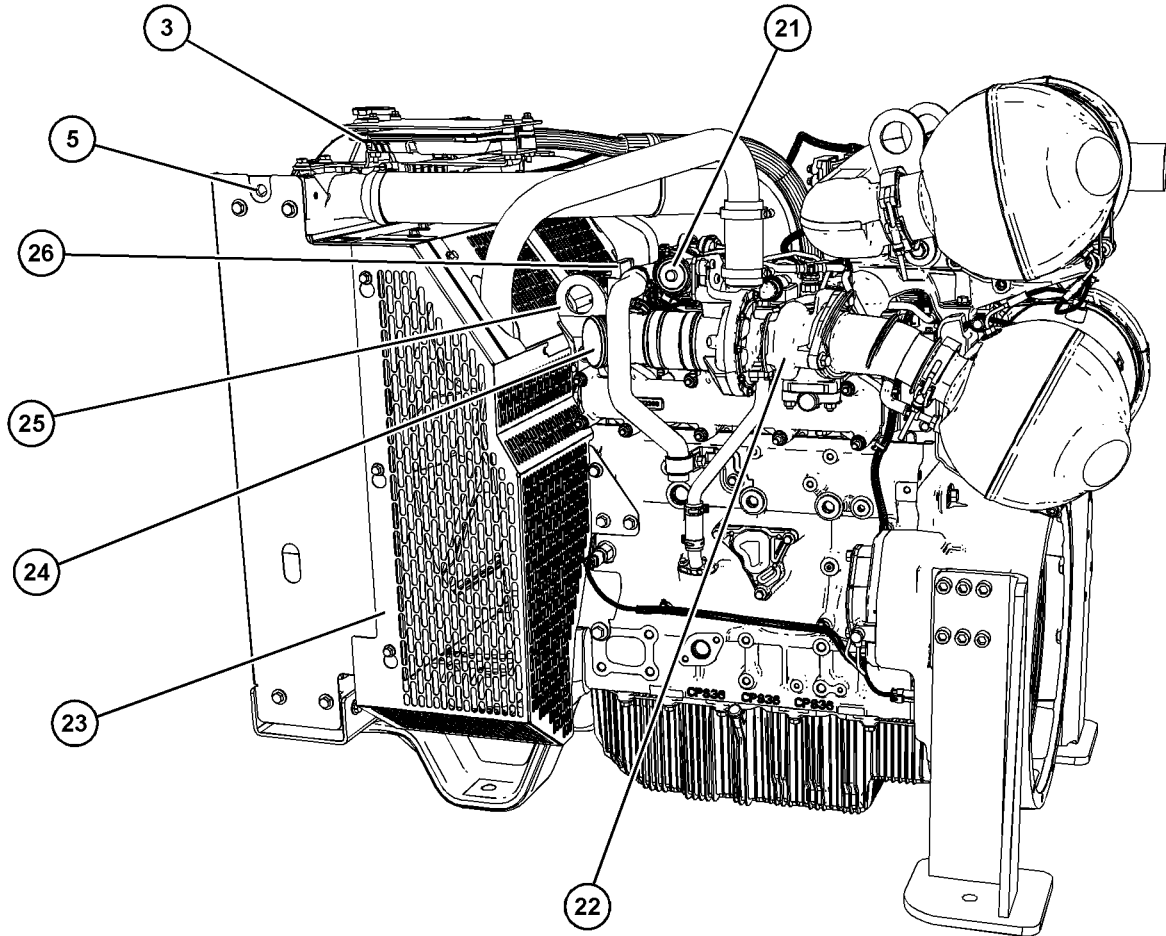

Illustration 37

g06737717

Typical example

(3) Electronic Control Module (ECM)
 (5) Radiator lifting point (1 of 2)
 (21) Actuator for turbocharger

(22) Turbocharger
 (23) Fan guard
 (24) Air intake from air cleaner

(25) Engine Front lifting eye
 (26) Upper Oil filler

Loose or Off Engine Components for 904J-E36TA IOPU

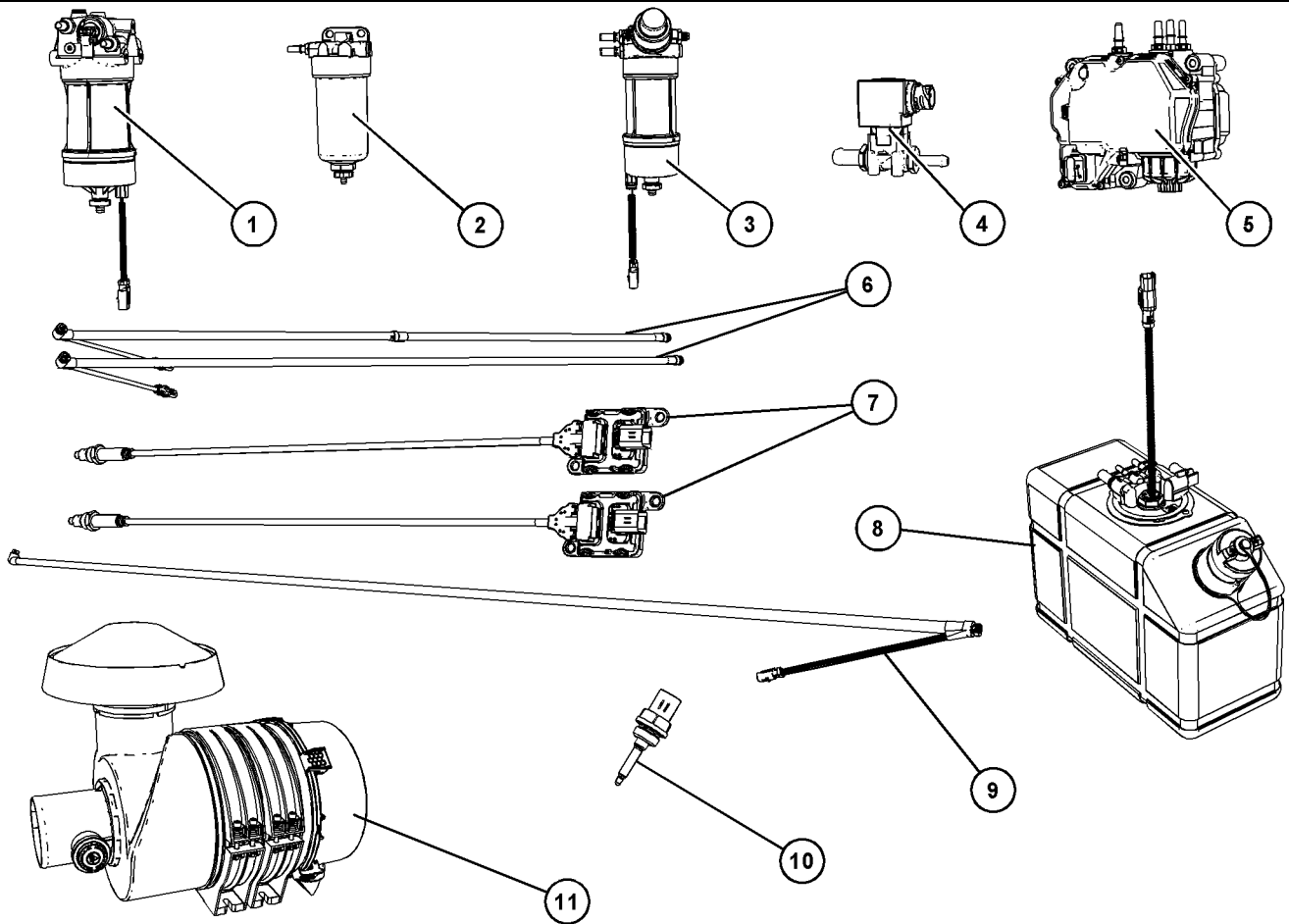

Illustration 38

g06737944

Typical example

- | | | |
|---|---|--|
| <p>(1) Primary fuel filter, combined with electric fuel priming pump and Water-In-Fuel (WIF) sensor</p> <p>(2) If equipped, secondary fuel filter</p> | <p>(3) Primary fuel filter, combined with manual fuel priming pump and Water-In-Fuel (WIF) sensor</p> <p>(4) Coolant diverter valve</p> <p>(5) Diesel Exhaust Fluid (DEF) pump with DEF pump filter</p> | <p>(6) DEF heated lines</p> <p>(7) NOx sensors</p> <p>(8) DEF tank with DEF header installed</p> <p>(9) line</p> <p>(10) Inlet temperature sensor</p> <p>(11) Engine air cleaner</p> |
|---|---|--|

904J-E28T Industrial Open Power Unit (IOPU)

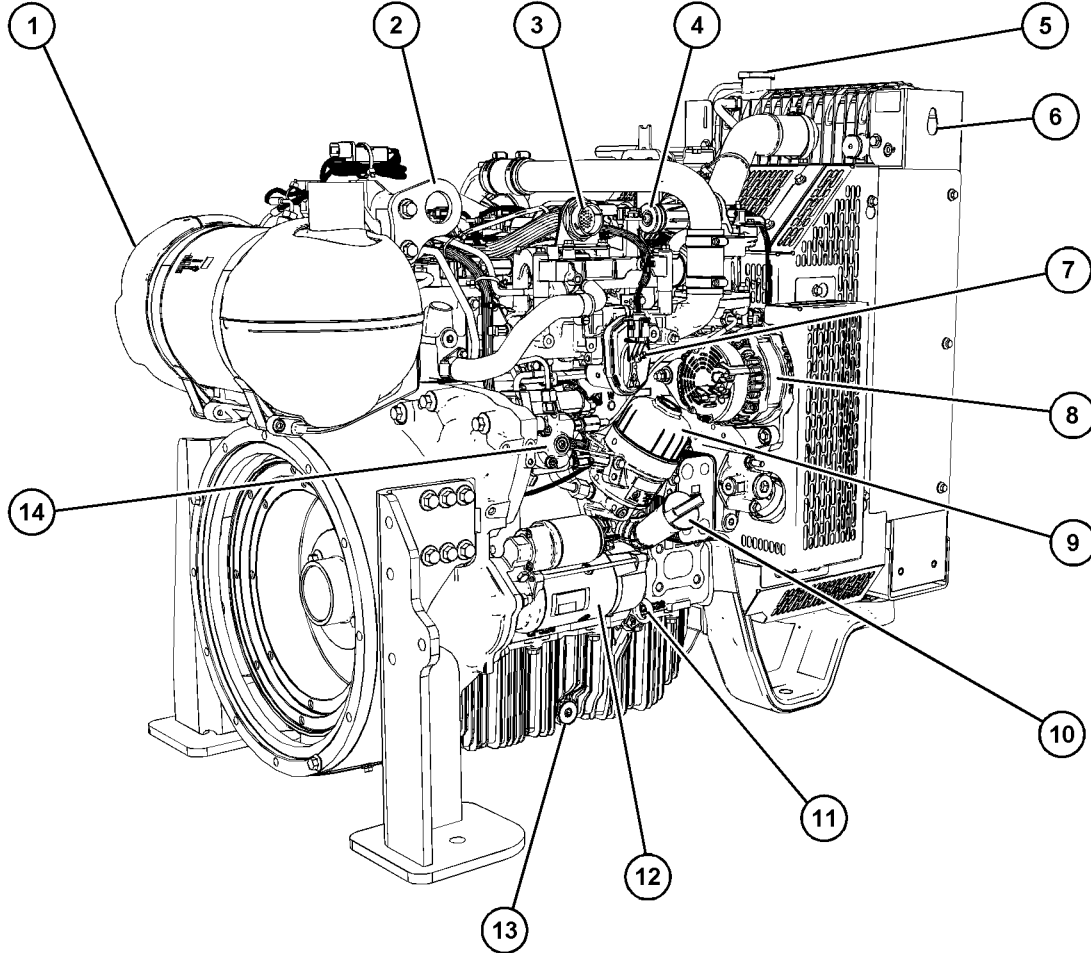

Illustration 39

g07534814

Typical example

- | | | |
|--|-------------------------------------|------------------------------|
| (1) Diesel Particulate Filter (DPF) and Diesel Oxidation Catalyst (DOC) combined | (5) Radiator filler cap | (10) Lower Oil filler |
| (2) Engine Rear lifting eye | (6) Radiator lifting point (1 of 2) | (11) Oil gauge (Dipstick) |
| (3) Engine harness interface | (7) Throttle control valve | (12) Starting motor |
| (4) NOx Reduction System (NRS) valve | (8) Alternator | (13) Oil drain plug |
| | (9) Oil filter assembly | (14) High-pressure fuel pump |

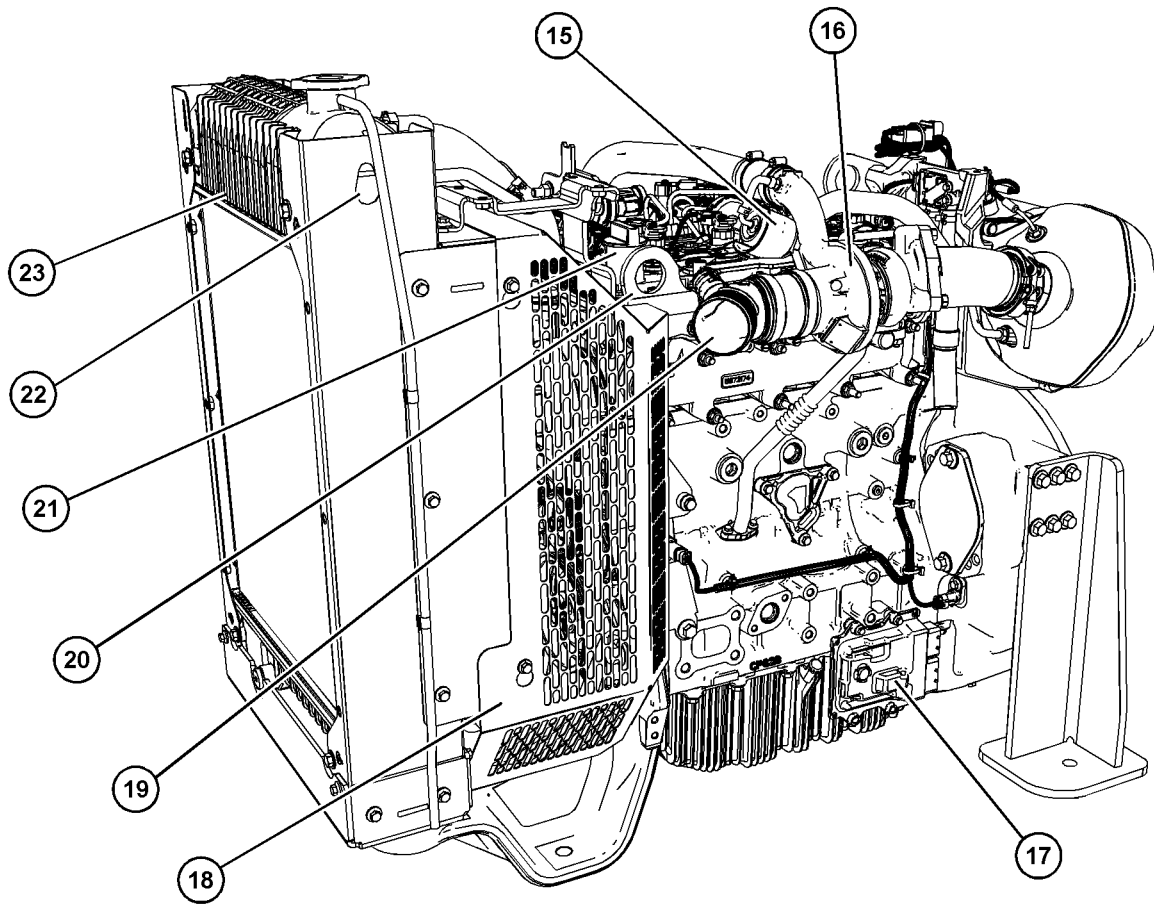

Illustration 40

g07534884

Typical example

(15) Actuator for turbocharger
 (16) Turbocharger
 (17) Electronic Control Module (ECM)
 (transport location)

(18) Fan guard
 (19) Air intake from air cleaner
 (20) Engine front lifting eye
 (21) Upper oil filler

(22) Radiator lifting point (2 of 2)
 (23) Radiator

Loose or Off Engine Components for 904J-E28T IOPU

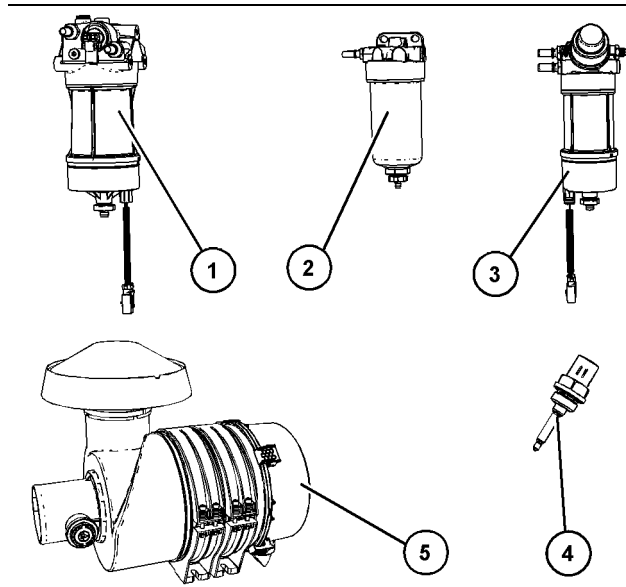

Illustration 41

g06740514

Typical example

- (1) Primary fuel filter, combined with electric fuel priming pump and Water-In-Fuel (WIF) sensor
- (2) If equipped, secondary fuel filter
- (3) Primary fuel filter, combined with manual fuel priming pump and Water-In-Fuel (WIF) sensor
- (4) Inlet temperature sensor
- (5) Engine air cleaner

i09951751

Model View Illustrations

The following model views show typical features of the engine. Due to individual applications, your engine may appear different from the illustrations.

904J-E36TA Electropak

Illustration 42

g07668328

Typical example

- | | | |
|--|--------------------------------------|---------------------------------------|
| (1) Diesel Particulate Filter (DPF) and Diesel Oxidation Catalyst (DOC) combined | (8) Engine coolant filler cap | (16) Lower Oil filler |
| (2) Engine Rear lifting eye | (9) Radiator | (17) Starting motor |
| (3) Engine air cleaner | (10) Radiator lifting point (1 of 2) | (18) Primary fuel filter |
| (4) Upper Oil filler Radiator filler cap | (11) Radiator drain plug | (19) High-pressure fuel pump |
| (5) Engine Front lifting eye | (12) Alternator | (20) Throttle control valve |
| (6) Electronic Control Module (ECM) | (13) Oil filter assembly | (21) Engine harness interface |
| (7) Charge Air cooler | (14) Oil gauge (Dipstick) | (22) NOx Reduction System (NRS) valve |
| | (15) Oil drain plug | |

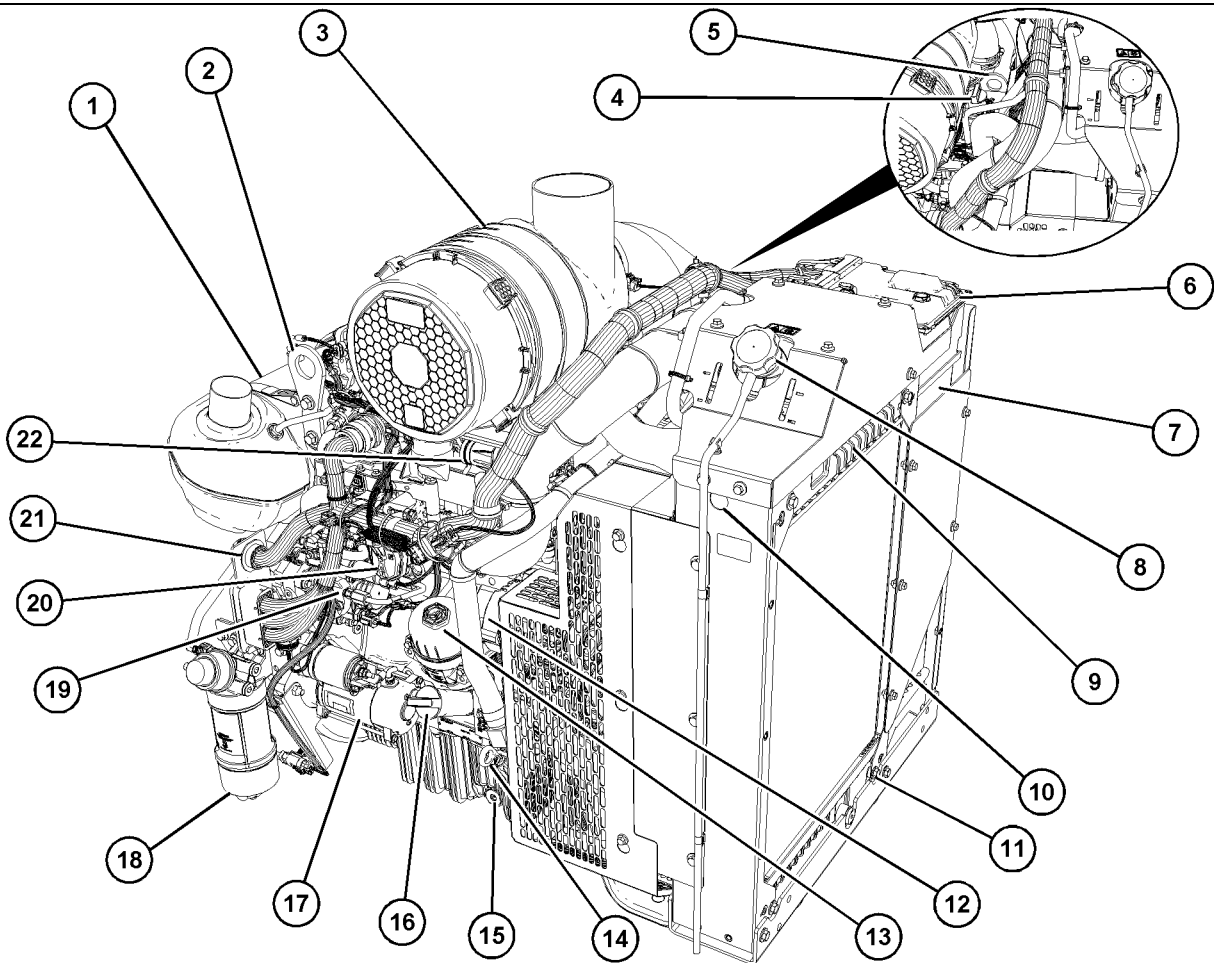
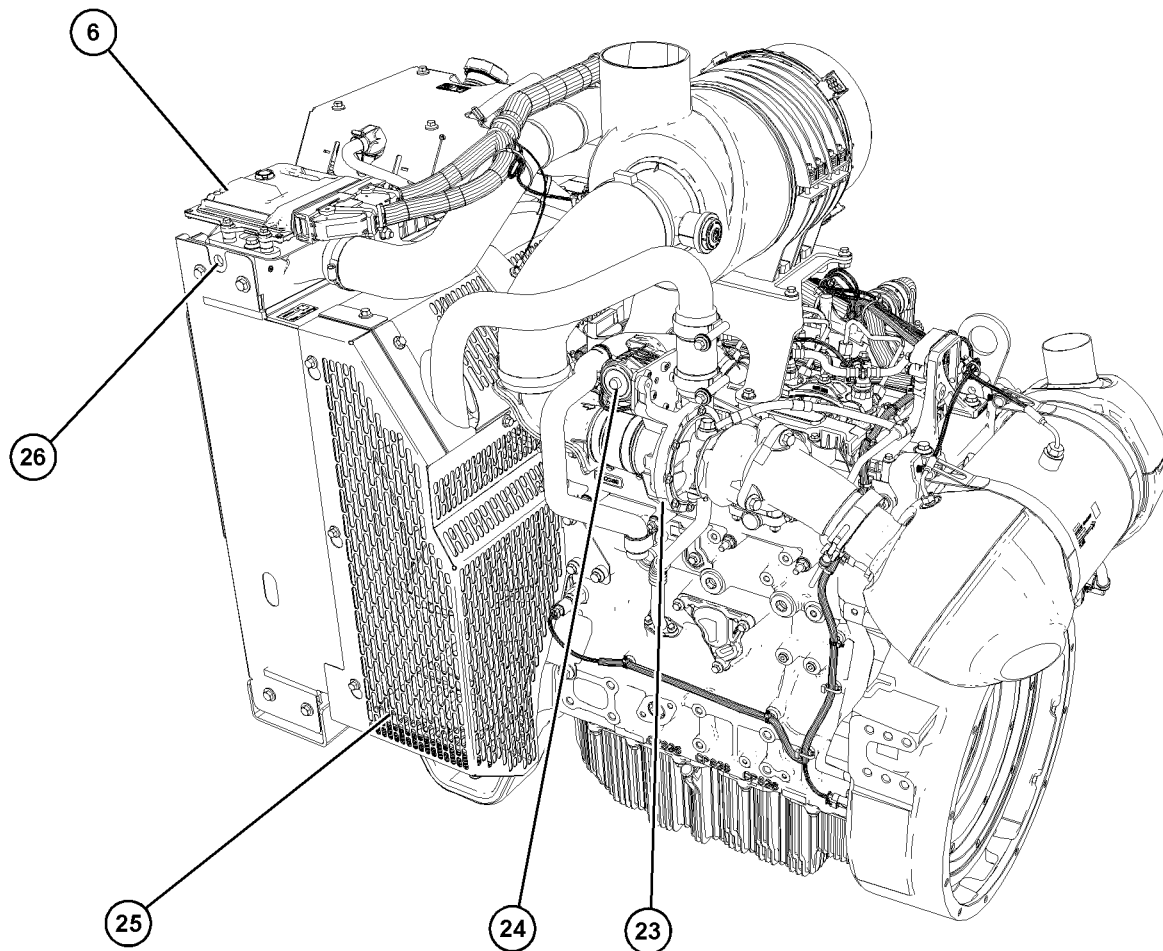

Illustration 43

g07668332

Typical example

(6) Electronic Control Module (ECM)
(23) Turbocharger

(24) Actuator for turbocharger
(25) Fan guard

(26) Radiator lifting point (2 of 2)

i07943897

Product Description**904J-E36TA Industrial Engine**

The Perkins 904J-E36TA industrial engine is a single turbocharged, air to air charge cooled engine with an engine prefix of FW.

The engine aftertreatment system is configured:

- Diesel Oxidation Catalyst (DOC)
- Diesel Particulate Filter (DPF)

The Perkins 904J-E36TA industrial engine is a single turbocharged, air to air charge cooled engine with an engine prefix of FX.

The engine aftertreatment system is configured:

- Diesel Oxidation Catalyst (DOC)
- Diesel Particulate Filter (DPF)
- Selective Catalytic Reduction (SCR)

904J-E28T and 904J-E28TA Industrial Engines

The Perkins 904J-E28T and 904J-E28TA industrial engines are single turbocharged engine. The engine may be turbocharged or turbocharged with an air charge cooler.

The engine aftertreatment system is configured as follows:

- Diesel Oxidation Catalyst (DOC)

- Diesel Particulate Filter (DPF)

Engine Specifications

The configuration will depend on the power output of the engine.

Note: The front end of the engine is opposite the flywheel end of the engine. The left and the right sides of the engine are determined from the flywheel end. The number 1 cylinder is the front cylinder.

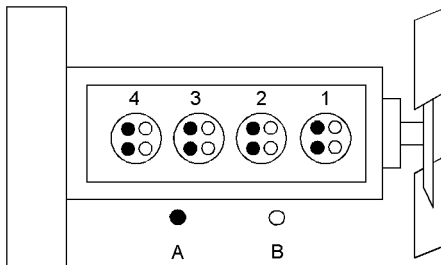

Illustration 44

g06297997

Typical example

- (A) Inlet valves
(B) Exhaust valves

Table 1

904J-E36TA and Engine Specifications	
Operating Range (rpm)	800 to 2400 ⁽¹⁾
Number of Cylinders	4 In-Line
Bore	98 mm (3.86 inch)
Stroke	120 mm (4.72 inch)
Power (Model FW)	55.4 kW (74.29 hp)
Power (Model FX)	70 to 100 kW (93.87 to 134.1 hp)
Aspiration	Turbocharged charge cooled
Compression Ratio	17:1
Displacement	3.62 L (220.97 cubic inch)
Firing Order	1-3 -4-2
Valves per cylinder	4
Rotation (flywheel end)	Counterclockwise

⁽¹⁾ The operating rpm depends on the engine rating, the application, and the configuration of the throttle.

Table 2

904J-E28T and 904J-E28TA Engine Specifications	
Operating Range (rpm)	800 to 2400 ⁽¹⁾
Number of Cylinders	4 In-Line
Bore	90 mm (3.54 inch)
Stroke	110 mm (4.33 inch)
Power rating	50 kW to 55.4 kW (67.05 hp to 74.29 hp)
Aspiration	Turbocharged and Turbocharged charge cooled
Compression Ratio	17:1
Displacement	2.8 L (170.87 cubic inch)
Firing Order	1-3 -4-2
Valves per cylinder	4
Rotation (flywheel end)	Counterclockwise

⁽¹⁾ The operating rpm depends on the engine rating, the application, and the configuration of the throttle.

Electronic Engine Features

The engine and aftertreatment operating conditions are monitored. The Electronic Control Module (ECM) controls the response of the engine to these conditions and to the demands of the operator. These conditions and operator demands determine the precise control of fuel injection by the ECM. The electronic engine control system provides the following features:

- Engine monitoring
- Engine speed governing
- Control of the injection pressure
- Cold start strategy
- Automatic air/fuel ratio control
- Torque rise shaping
- Injection timing control
- System diagnostics
- NOx reduction system control
- Aftertreatment system control

The ECM provides an electronic governor that controls the injector output to maintain the desired engine speed.

For more information on electronic engine features, refer to the Operation and Maintenance Manual, “Features and Controls” topic (Operation Section).

Engine Diagnostics

The engine has built-in diagnostics to ensure that the engine systems are functioning correctly. The operator will be alerted to the condition by a “Stop or Warning” lamp. Under certain conditions, the engine horsepower and the vehicle speed may be limited. The electronic service tool may be used to display the diagnostic codes.

There are three types of diagnostic codes: active, logged, and event.

Most of the diagnostic codes are logged and stored in the ECM. For additional information, refer to the Operation and Maintenance Manual, “Engine Diagnostics” topic (Operation Section).

Engine Cooling and Lubrication

The cooling system and lubrication system consists of the following components:

- Belt driven water pump
- Water temperature regulator which regulates the engine coolant temperature
- Gear-driven gerotor type oil pump
- Oil cooler

The engine lubricating oil is supplied by a gerotor type oil pump. The engine lubricating oil is cooled and the engine lubricating oil is filtered. The bypass valve can provide unrestricted flow of lubrication oil to the engine if the oil filter element should become plugged.

Engine efficiency, efficiency of emission controls, and engine performance depend on adherence to proper operation and maintenance recommendations. Engine performance and efficiency also depend on the use of recommended fuels, lubrication oils, and coolants. Refer to this Operation and Maintenance Manual, “Maintenance Interval Schedule” for more information on maintenance items.

Engine Service Life

Engine efficiency and maximum utilization of engine performance depend on the adherence to proper operation and maintenance recommendations. In addition, use recommended fuels, coolants, and lubricants. Use the Operation and Maintenance Manual as a guide for required engine maintenance.

Expected engine life is generally predicted by the average power that is demanded. The average power that is demanded is based on fuel consumption of the engine over time. Reduced hours of operation at full throttle and/or operating at reduced throttle settings result in a lower average power demand. Reduced hours of operation will increase the length of operating time before an engine overhaul is required. For more information, refer to the Operation and Maintenance Manual, “Overhaul Considerations” topic (Maintenance Section).

Aftermarket Products and Perkins Engines

Perkins does not warrant the quality or performance of non-Perkins fluids and filters.

When auxiliary devices, accessories, or consumables (filters, additives, catalysts) which are made by other manufacturers are used on Perkins products, the Perkins warranty is not affected simply because of such use.

However, failures that result from the installation or use of other manufacturers devices, accessories, or consumables are NOT Perkins defects. Therefore, the defects are NOT covered under the Perkins warranty.

Aftertreatment System

The aftertreatment system is approved for use by Perkins. To be emission-compliant, only the approved Perkins aftertreatment system must be used on a Perkins engine.

Product Identification Information

i07373047

Plate Locations and Film Locations

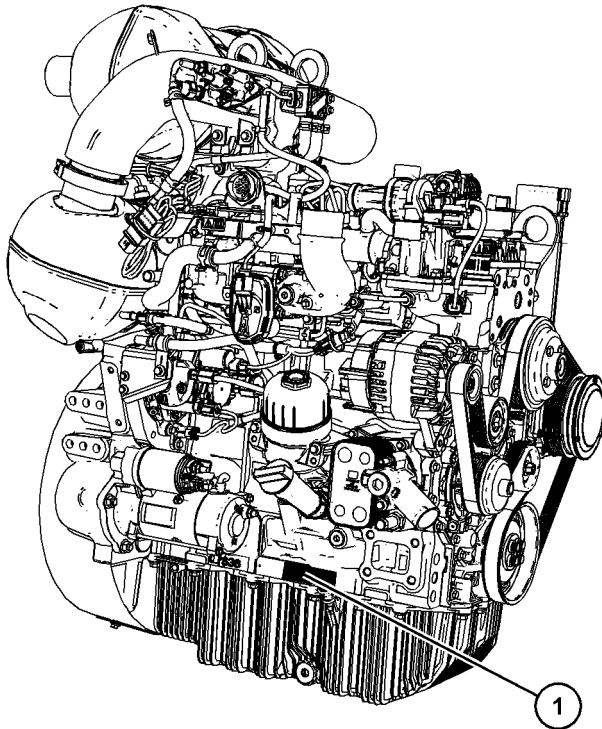

Perkins dealers or Perkins distributors need all these numbers to determine the components that were included with the engine. This information permits accurate identification of replacement part numbers.

The numbers for fuel setting information for electronic engines are stored within the flash file. These numbers can be read by using the electronic service tool.

Serial Number Plate (1)

The engine serial number plate is on the right side of the cylinder block to the rear of the front engine mounting.

Illustration 45

g06298126

Typical example

(1) Engine serial number plate location

Perkins engines are identified by an engine serial number.

An example of an engine number is
FW****U000001D.

**** _____ The list number for the engine
FW _____ Type of engine
U _____ Built in the United Kingdom
000001 _____ Engine Serial Number
D _____ Year of Manufacture

i07944182

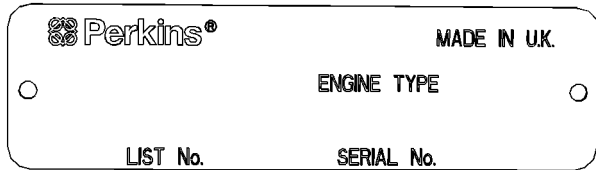

Illustration 46

g06298094

Serial number plate

i08043623

Emissions Certification Film

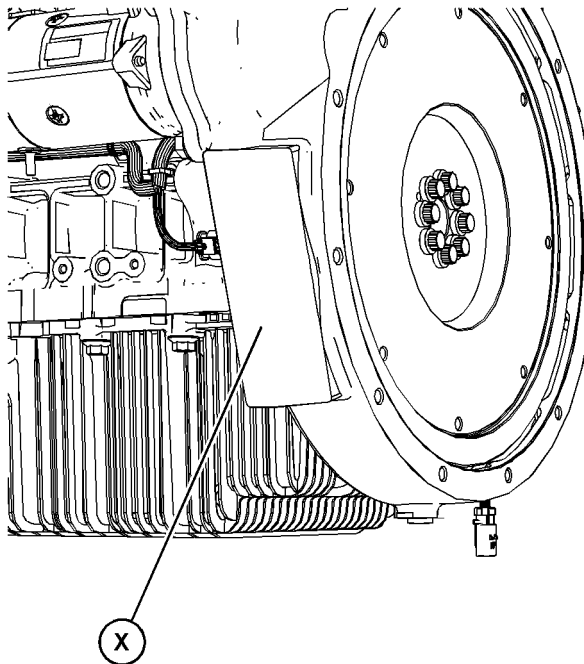

Illustration 47

g06522161

Typical location of the engine emission label

The engine emission label is typically installed on the flywheel housing at Position (X). An extra engine emission label may be supplied loose.

Reference Information

Information for the following items may be needed to order parts. Locate the information for your engine. Record the information in the appropriate space. Make a copy of this list for a record. Keep the information for future reference.

Record for Reference

Engine Model _____

Engine Serial number _____

Engine Low Idle rpm _____

Engine Full Load rpm _____

Primary Fuel Filter Element _____

Secondary Fuel Filter Element _____

Lubrication Oil Filter Element _____

Auxiliary Oil Filter Element _____

Total Lubrication System Capacity _____

Total Cooling System Capacity _____

Air Cleaner Element _____

Drive Belt _____

Clean Emissions Module

Part Number _____

Serial Number _____

Diesel Exhaust Fluid (DEF) Pump

Part Number _____

Serial Number _____

Operation Section

Lifting and Storage

i09953834

Product Lifting

NOTICE

Always inspect lifting eyebolts and all other lifting equipment for damage before performing any lifting. Never bend the eyebolts and the brackets. Never perform product lifting if components are damaged. Only load the eyebolts and the brackets under tension. Remember that the capacity of an eyebolt is less as the angle between the supporting members and the object becomes less than 90 degrees.

When it is necessary to remove a component at an angle, only use a link bracket that is properly rated for the weight.

Use a hoist to remove heavy components. Use an adjustable lifting beam to lift the engine. All supporting members (chains and cables) should be parallel to each other. The chains and cables should be perpendicular to the top of the object that is being lifted.

To obtain the correct balance for lifting an application, adjust the chain lengths

Lifting eyes are designed and installed for the specific engine arrangement. Alterations to the lifting eyes and/or the engine make the lifting eyes and the lifting fixtures obsolete. If alterations are made, ensure that proper lifting devices are provided.

There are several different designs of lifting eyes. The following sections give examples of lifting eyes on the engine, engine, and aftertreatment and Industrial Open Power Unit (IOPU).

Consult your Perkins distributor for information regarding fixtures for proper engine lifting.

904J-E36TA Industrial Engine

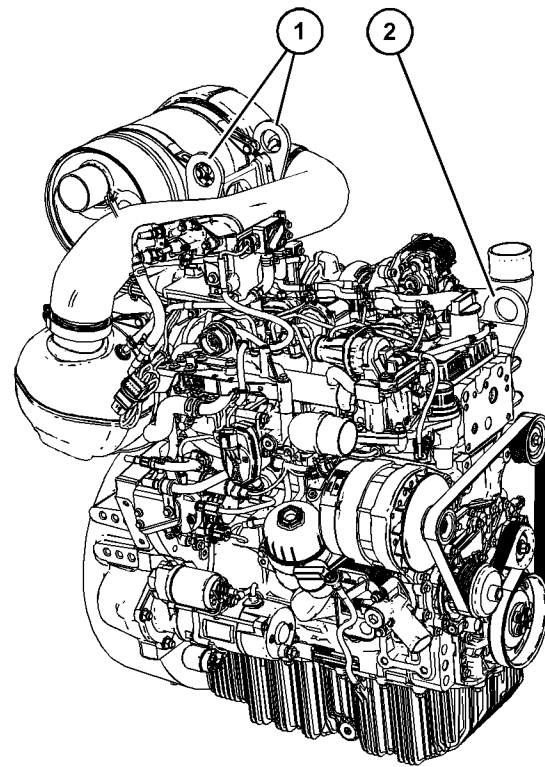

Illustration 48

g06298473

Typical example

- (1) Rear lifting eyes
- (2) Front lifting eye

Use all 3 lifting eyes when lifting engine assembly.

Perkins recommends that model-specific cradles are used to store and transport engines. Supporting engines on the sump/oil pan is not recommended under any circumstances. This action is for both safety and quality reasons.

904J-E36TA Industrial Engine Equipped With a Balancer

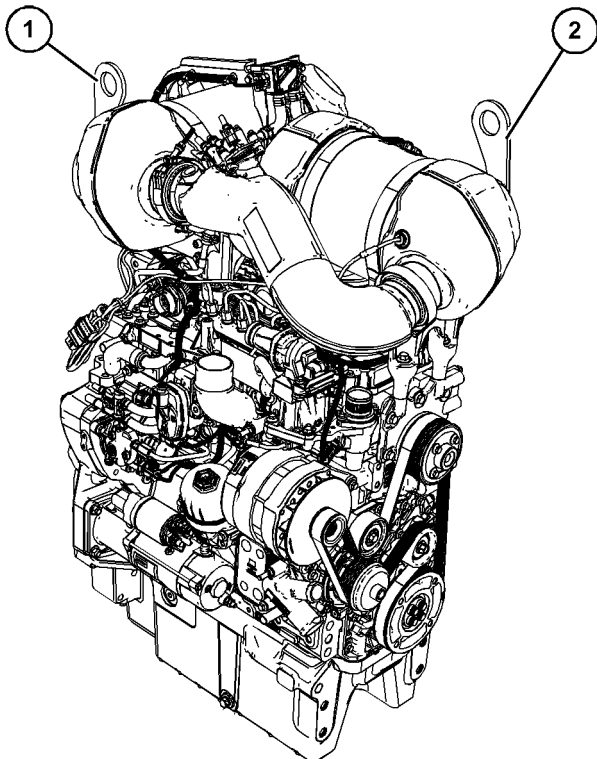

Illustration 49

g06511783

Typical example

- (1) Rear lifting eye
- (2) Front lifting eye

Use both lifting eyes when lifting engine assembly.

Perkins recommends that model-specific cradles are used to store and transport engines. Supporting engines on the sump/oil pan is not recommended under any circumstances. This action is for both safety and quality reasons.

904J-E36TA IOPU

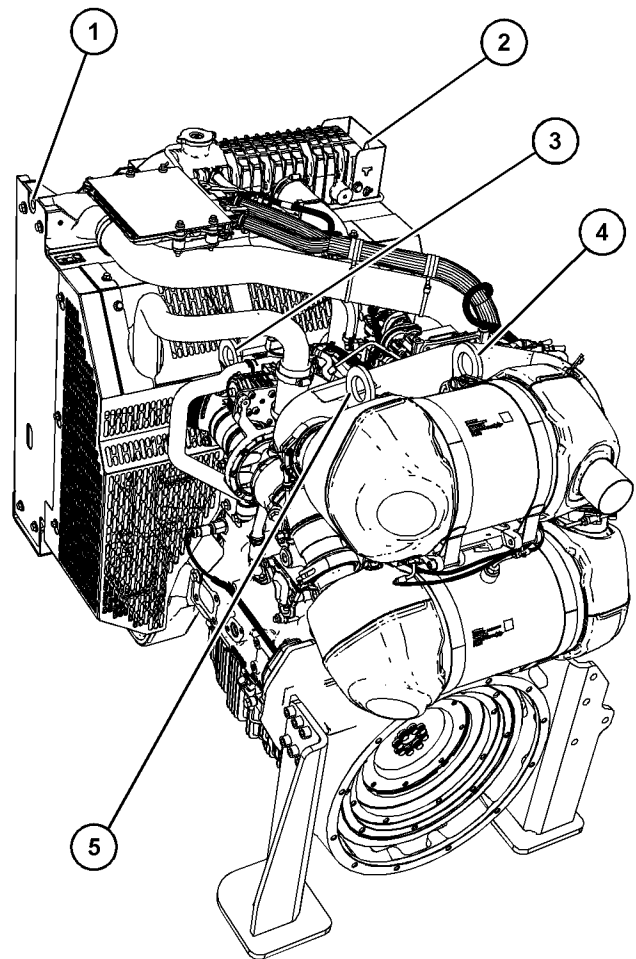

Illustration 50

g06742363

Typical example

- (1) Radiator lifting eye (1 of 2)
- (2) Radiator lifting eye (2 of 2)
- (3) Front lifting eye
- (4) Rear lifting eye
- (5) Rear lifting eye

Use all 3 lifting eyes when lifting engine assembly.

Use both lifting eyes when lifting radiator assembly.

Use all the lifting eyes when lifting IOPU.

904J-E28T and 904J-E28TA Industrial Engines

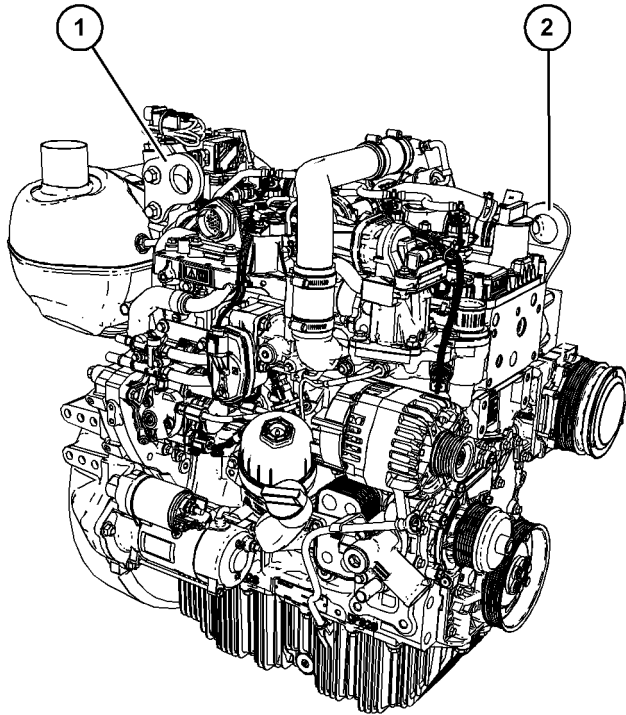

Illustration 51

g06458398

Typical example

- (1) Rear lifting eye
- (2) Front lifting eye

Use both lifting eyes when lifting engine assembly.

Perkins recommends that model-specific cradles are used to store and transport engines. Supporting engines on the sump/oil pan is not recommended under any circumstances. This action is for both safety and quality reasons.

904J-E28T Industrial Open Power Unit (IOPU)

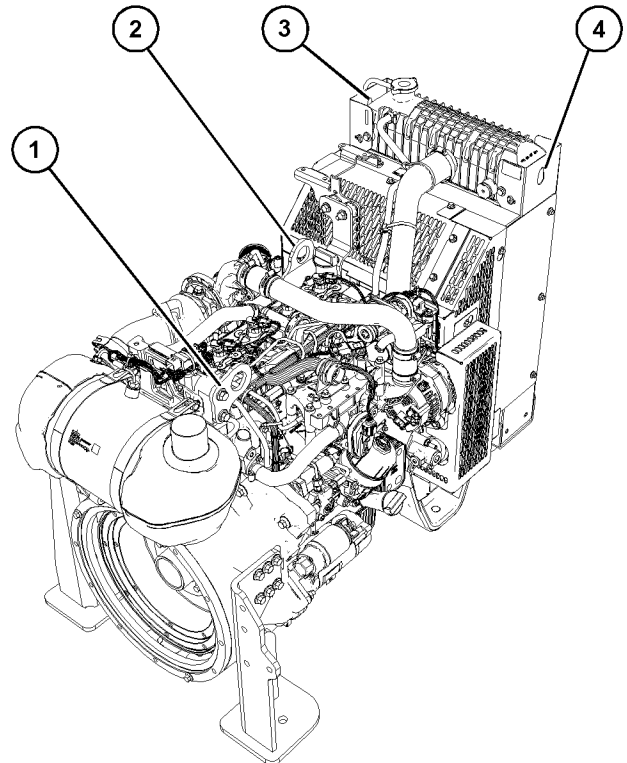

Illustration 52

g07535104

Typical example

- (1) Rear lifting eye
- (2) Front lifting eye
- (3) Radiator lifting eye (1 of 2)
- (4) Radiator lifting eye (2 of 2)

Use both lifting eyes when lifting engine assembly.

Use both lifting eyes when lifting radiator assembly.

Use all the lifting eyes when lifting the IOPU.

904J-E36TA ElectropaK

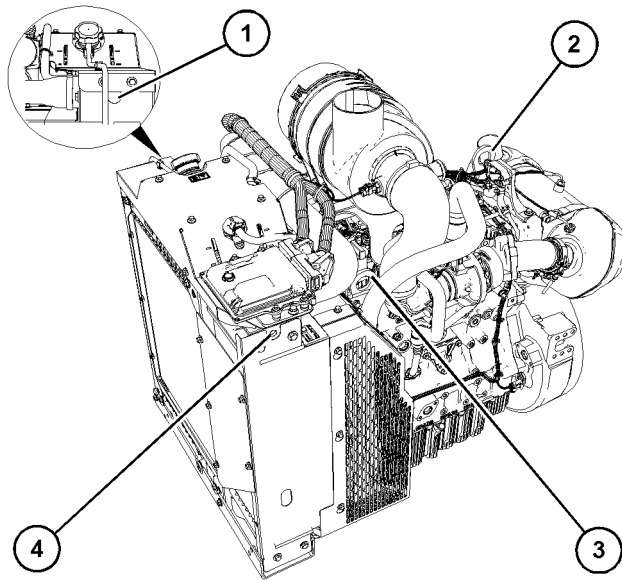

Illustration 53

g07669901

Typical example

- (1) Radiator lifting eye (1 of 2)
- (2) Rear lifting eye
- (3) Front lifting eye
- (4) Radiator lifting eye (2 of 2)

Use both lifting eyes when lifting engine assembly.

Use both lifting eyes when lifting radiator assembly.

Use all the lifting eyes when lifting ElectropaK.

i07621581

Product Storage (Engine and Aftertreatment)

Perkins are not responsible for damage which may occur when an engine is in storage after a period in service.

Your Perkins dealer or your Perkins distributor can help with preparing the engine for extended storage periods.

In some applications, the engine can be equipped with delayed engine shutdown. Allow at least 2 minutes after the engine has stopped before you turn the battery disconnect switch to OFF. Disconnecting the battery power too soon will prevent purging of the DEF fluid lines after the engine is shut down. Also, during the 2 minutes the engine electronic control module is active storing information from the engine and aftertreatment sensors.

Condition for Storage

The engine must be stored in a water proof building. The building must be kept at a constant temperature. Engines that are filled with Perkins ELC will have coolant protection to an ambient temperature of -36°C (-32.8°F). The engine must not be subjected to extreme variations in temperature or humidity.

Storage Period

An engine can be stored for up to 6 months provided all the recommendations are adhered to.

Storage Procedure

Keep a record of the procedure that has been completed on the engine.

Note: Do not store an engine that has biodiesel in the fuel system.

1. Ensure that the engine is clean and dry.
 - a. If the engine has been operated using biodiesel, the system must be drained and new filters installed. The fuel tank will require flushing.
 - b. Fill the fuel system with an ultra low sulfur fuel. For more information on acceptable fuels refer to this Operation and Maintenance Manual, "Fluid Recommendations". Operate the engine for 15 minutes to remove all biodiesel from the system.
2. Drain any water from the primary filter water separator. Ensure that the fuel tank is full.
3. The engine oil will not need to be drained to store the engine. Provided the correct specification of engine oil is used the engine can be stored for up to 6 months. For the correct specification of engine oil refer to this Operation and Maintenance Manual, "Fluid Recommendations".
4. Remove the drive belt from the engine.

Sealed Coolant System

Ensure that the cooling system is filled with the correct specification of coolant. Refer to this Operation and Maintenance Manual, "Fluid Recommendations".

Open Cooling System

Ensure that all coolant drain plugs have been opened. Allow the coolant to drain. Install the drain plugs. Place a vapor phase inhibitor into the system. The coolant system must be sealed once the vapor phase inhibitor has been introduced. The effect of the vapor phase inhibitor will be lost if the cooling system is open to the atmosphere.

For maintenance procedures refer to this Operation and Maintenance Manual.

Monthly Checks

The crankshaft must be rotated to change the spring loading on the valve train. Rotate the crankshaft more than 180 degrees. Visibly check for damage or corrosion to the engine and aftertreatment.

Ensure that the engine and aftertreatment are covered completely before storage. Log the procedure in the record for the engine.

Aftertreatment

The engine must be allowed to perform a Diesel Exhaust Fluid (DEF) purge before the battery disconnect switch is turned off. In some applications, the engine can be equipped with delayed engine shutdown. Allow 2 minutes after the engine has stopped before using the battery disconnect switch.

The exhaust outlet of the aftertreatment must be capped. To prevent damage to the exhaust outlet connection during storage, the weight of the CEM must not act on the exhaust outlet.

DEF Tank Storage

1. Ensure normal engine shutdown, allow the DEF to be purged. Do not disconnect the battery disconnect switch, allow 2 minutes after key off before disconnection.
2. Fill the tank with DEF that meets all the requirement defined in ISO 22241-1.
3. Ensure that all DEF lines and electrical connections are reconnected prior to storage, to prevent DEF crystals from forming.
4. Ensure that the DEF filler cap is correctly installed.

Removal from Storage

DEF has a limited life, refer to table 3 for the time and temperature range. DEF that is outside this range MUST be replaced.

On removal from storage the DEF quality in the tank must be tested with a refractometer. The DEF in the tank must meet the requirements defined in ISO 22241-1 and comply with table 3 .

1. If necessary, drain the tank and fill with DEF that meets ISO 22241-1.
2. Replace the DEF filter, refer to this Operation and Maintenance Manual, "Diesel Exhaust Fluid Filter-Clean/Replace".
3. Ensure that the drive belt is correctly installed. Ensure that all engine coolant and engine oil has the correct specification and grade. Ensure that the coolant and the engine oil are at the correct level. Start the engine. If a fault becomes active turn off the engine, allow 2 minutes for the DEF system to purge, then restart the engine.
4. If the fault remains active, refer to Troubleshooting for more information.

Table 3

Temperature	Duration
10° C (50° F)	36 months
25° C (77° F)	18 months
30° C (86° F)	12 months
35° C (95° F) ⁽¹⁾	6 months

⁽¹⁾ At 35° C, significant degradation can occur. Check every batch before use.

Features and Controls

i07925952

Alarms and Shutoffs

Shutoffs

The shutoffs are electrically operated or mechanically operated. The electrically operated shutoffs are controlled by the ECM.

Shutoffs are set at critical levels for the following items:

- Operating temperature
- Operating pressure
- Operating level
- Operating rpm

The particular shutoff may need to be reset before the engine will start.

NOTICE

Always determine the cause of the engine shutdown. Make necessary repairs before attempting to restart the engine.

Be familiar with the following items:

- Types and locations of shutoff
- Conditions which cause each shutoff to function
- The resetting procedure that is required to restart the engine

Alarms

The alarms are electrically operated. The operations of the alarms are controlled by the ECM.

The alarm is operated by a sensor or by a switch. When the sensor or the switch is activated, a signal is sent to the ECM. An event code is created by the ECM. The ECM will send a signal to illuminate the lamp.

Your engine may be equipped with the following sensors or switches:

Coolant temperature – The coolant temperature sensor indicates high jacket water coolant temperature.

Intake manifold air temperature – The intake manifold air temperature sensor indicates high intake air temperature.

Intake manifold pressure – The intake manifold pressure sensor checks the rated pressure in the engine manifold.

Fuel rail pressure – The fuel rail pressure sensor measures the high pressure or low pressure in the fuel rail. The ECM will Check the pressure.

Engine oil pressure – The engine oil pressure switch indicates when oil pressure drops below rated system pressure, at a set engine speed.

Engine overspeed – If the engine rpm exceeds the overspeed setting, the alarm will be activated.

Air filter restriction – The switch checks the air filter when the engine is operating.

User-defined switch – This switch can shut down the engine remotely.

Water in fuel switch – This switch checks for water in the primary fuel filter when the engine is operating.

Fuel temperature – The fuel temperature sensor monitors the pressurized fuel in the high-pressure fuel pump.

NRS absolute pressure and NRS delta pressure – A combined pressure sensor across the NRS valve.

Note: The sensing element of the coolant temperature sensor must be submerged in coolant to operate.

Engines may be equipped with alarms to alert the operator when undesirable operating conditions occur.

NOTICE

When an alarm is activated, corrective measures must be taken before the situation becomes an emergency in order to avoid possible engine damage.

If corrective measures are not taken within a reasonable time, engine damage could result. The alarm will continue until the condition is corrected. The alarm may need to be reset.

Note: If installed, the coolant level switch and the oil level switch are indicators. Both switches operate when the application is on level ground and the engine RPM at zero.

Aftertreatment System

- Diesel Oxidation Catalyst _____(DOC)
- Selective Catalyst Reduction _____(SCR)
- Diesel Particulate Filter _____(DPF)

Soot Sensors – The soot sensor monitor the soot level within the DPF.

NOx Sensors – Two NOx sensors monitor the NOx concentration within the exhaust gas before and after the selective catalyt reduction module.

Temperature Sensor – A temperature sensor after the engine exhaust gas exit, after the DOC and before the SCR module monitor the temperatures within the system.

DEF Tank Header Unit – The DEF level sensor monitors the volume of fluid in the tank and signals the ECM if the level drops below a given point.

Testing

Turning the keyswitch to the ON position will check the indicator lights on the control panel. All the indicator lights will be illuminated for 2 seconds after the keyswitch is operated. Replace suspect bulbs immediately.

Refer to Troubleshooting for more information.

i05408886

Battery Disconnect Switch (If Equipped)

Allow at least 2 minutes after the engine has stopped before you turn the battery disconnect switch to OFF. Disconnecting the battery power too soon will prevent purging of the Diesel Exhaust Fluid (DEF) lines after the engine is shut down. Also, during the 2 minutes the engine Electronic Control Module (ECM) is active storing information from the engine and aftertreatment sensors.

Not allowing the DEF purge to be performed can damage the DEF system. Not allowing the engine ECM time to store the information from the sensors can damage to emission control system.

Some applications, the engine can be equipped with a wait to disconnect lamp. The wait to disconnect lamp will be illuminated during engine operation and will be extinguished approximately 2 minutes after the engine has stopped.

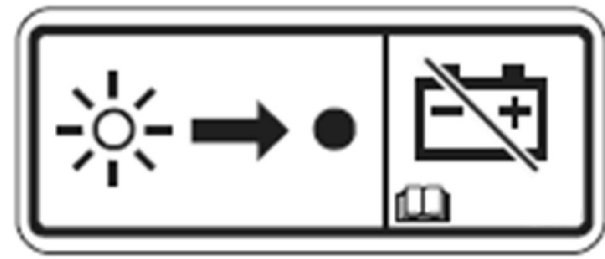

Illustration 54

g03265058

Battery disconnect switch label

NOTICE

Do not turn off the battery disconnect switch until the indicator lamp has turned off. If the switch is turned off when the indicator lamp is illuminated the Diesel Exhaust Fluid (DEF) system will not purge the DEF. If the DEF does not purge, DEF could freeze and damage the pump and lines.

NOTICE

Never move the battery disconnect switch to the OFF position while the engine is operating. Serious damage to the electrical system could result.

i09675948

Gauges and Indicators

Your engine may not have the same gauges or all of the gauges that are described. For more information about the gauge package, see the OEM information.

Gauges provide indications of engine performance. Ensure that the gauges are in good working order. Determine the normal operating range by observing the gauges over a period.

Noticeable changes in gauge readings indicate potential gauge or engine problems. Problems may also be indicated by gauge readings that change even if the readings are within specifications. Determine and correct the cause of any significant change in the readings. Consult your Perkins dealer or your Perkins distributor for assistance.

Some engine applications are equipped with Indicator Lamps. Indicator lamps can be used as a diagnostic aid. There are two lamps. One lamp has an orange lens and the other lamp has a red lens.

These indicator lamps can be used in two ways:

Operation Section
Gauges and Indicators

- The indicator lamps can be used to identify the current operational status of the engine. The indicator lamps can also indicate that the engine has a fault. This system is automatically operated via the ignition switch.
- The indicator lamps can be used to identify active diagnostic codes. This system is activated by pressing the Flash Code button.

Refer to the Troubleshooting Guide, "Indicator Lamps" for further information.

NOTICE

If no oil pressure is indicated, STOP the engine. If maximum coolant temperature is exceeded, STOP the engine. Engine damage can result.



Engine Oil Pressure – The oil pressure should be greatest after a cold engine is started. The typical engine oil pressure with SAE10W40 is 350 to 450 kPa (50 to 65 psi) at rated rpm.

A lower oil pressure is normal at low idle. If the engine speed and load are stable and the gauge reading changes, perform the following procedure:

1. Remove the load.
2. Stop the engine.
3. Check and maintain the oil level.



Jacket Water Coolant Temperature – Typical temperature range is 82° to 94°C (179.6° to 169.2°F). This temperature range will vary according to engine load and the ambient temperature.

A 100 kPa (14.5 psi) radiator cap must be installed on the cooling system. The maximum temperature for the cooling system is 108° C (226.4° F). This temperature is measured at the outlet for the water temperature regulator. The engine coolant temperature is monitored by the engine sensors and the engine ECM. This programming cannot be altered. Derates can occur if the maximum engine coolant temperature is exceeded.

If the engine is operating above the normal range, reduce the engine load. If high coolant temperatures are a frequent event, perform the following procedures:

1. Reduce the load on the engine.
2. Determine if the engine must be shut down immediately or if the engine can be cooled by reducing the load.
3. Inspect the cooling system for leaks. If necessary, consult your Perkins dealer or your Perkins distributor for assistance.



Tachometer – This gauge indicates engine speed (rpm). When the throttle control lever is moved to the full throttle position without load, the engine is running at high idle. The engine is running at the full load rpm when the throttle control lever is at the full throttle position with maximum rated load.

NOTICE

To help prevent engine damage, never exceed the high idle rpm. Overspeeding can result in serious damage to the engine. Operation at speeds exceeding high idle rpm should be kept to a minimum.



Ammeter – This gauge indicates the amount of charge or discharge in the battery charging circuit. Operation of the indicator should be to the "+" side of "0" (zero).



Engine - Electrical Preheat – This indicator comes "ON" to show that the glow plug preheat is active. The engine should only be set to "RUN" after indicator lamp on the display turns "OFF" .



Fuel Level – This gauge indicates the fuel level in the fuel tank. The fuel level gauge operates when the "START/STOP" switch is in the "on" position.



Service Hour Meter – The gauge indicates total operating hours of the engine.

Indicator Lamps

- Shutdown lamp
- Warning lamp
- Low oil pressure lamp
- Wait to start lamp (Glow plug warning lamp)

For information, refer to this manual, "Monitoring System (Table for the Indicator Lamps)" for the sequence of operation of the shutdown lamp and the warning lamp.

The function of the wait to start lamp is automatically controlled at engine start-up.

The function of the low oil pressure lamp is controlled by the engine ECM. If low oil pressure is detected, the lamp will be illuminated. The reason for the illumination of the low-pressure lamp should be investigated immediately.

The glow plug warning lamp will flash to show that the engine is being held at low speed. This function will be performed at engine starting and the duration will depend on ambient temperature and engine temperature.

The lamps will illuminate for 2 seconds to check that the lamps are functioning when the keyswitch is turned to the ON position. If any of the lamps stay illuminated, or a lamp fails to be illuminated the reason should be investigated immediately.

Aftertreatment Lamps and gauges

All applications will require the following lamps and gauges:

- Emission malfunction lamp
- Action indicator lamp
- Gauge for Diesel Exhaust Fluid (DEF)
- Low warning lamp for DEF
- Wait to disconnect lamp (optional)

The wait to disconnect lamp will be illuminated during engine operation and will be extinguished approximately 2 minutes after the engine has stopped. Do not disconnect the battery disconnect switch during the period the lamp is illuminated. The diesel exhaust fluid system will be purged during this time. Also, during the 2 minutes the engine electronic control module is active storing information from the engine and aftertreatment sensors.

Note: The wait to disconnect lamp will not be checked at key on.

i07622830

Monitoring System (Engine Indicators and Aftertreatment Indicators)

Engine Indicator Lamps

Note: When in operation the amber warning lamp has three states, solid, flashing, and fast flashing. The sequence is to give a visual indication of the importance of the warning. Some application can have an audible warning installed.

Ensure that the engine maintenance is carried out at the correct intervals. A lack of maintenance can result in illumination of the warning lamp. For the correct intervals of maintenance, refer to the Operation and Maintenance Manual, "Maintenance Interval Schedule".

Table 4

Indicator Lamp Table				
Warning Lamp	Shutdown Action Indicator Lamp	Lamp State	Description of the Indication	Engine Status
On	On	Lamp Check	When the keyswitch is moved to the ON position, the lamps come on for 2 seconds and the lamps will then go off.	The keyswitch is in the ON position but the engine has not yet been cranked.
If any of the indicators will not illuminate during indicator check, the fault must be investigated immediately If any Indicators stay illuminated or flash, the fault must be investigated immediately.				
Off	Off	No Faults	With the engine in operation, there are no active warnings, diagnostic codes, or event codes.	The engine is operating with no detected faults.
On Solid	Off	Warning	Level 1 warning	The engine is operating normally but there is one or more faults with the electronic management system for the engine.
As soon as possible the fault should be investigated.				
Flashing	Off	Warning	Level 2 warning	The engine continues to be operated, but the level of importance of the warning has increased. Depending on the particular fault and the severity the engine may be de-rated. The engine could be damaged if continued to be operated.
Stop the engine. Investigate the code.				
Flashing	On	Engine Shutdown	Level 3 warning If both the warning lamp and the shutdown lamp are in operation, this issue indicates one of the following conditions. 1. One or more of the shutdown values for the engine protection strategy has been exceeded. 2. A serious active diagnostic code has been detected. If installed, the audible warning will sound. After a short time period, the engine may shut down.	The engine is either shutdown or an engine shutdown is imminent. One or more monitored engine parameters have exceeded the limit for an engine shutdown. This pattern of lamps can be caused by the detection of a serious active diagnostic code. Contact your Perkins dealer or your Perkins distributor.

Flash Codes

Some applications may support flash codes. A flash code can be viewed by an indicator lamp that when asked will flash in a particular sequence. The indicator lamp used to view the codes is the warning lamp, the lamp can then be referred to as a diagnostic lamp. For more information refer to this Operation and Maintenance Manual, "Diagnostic Lamp".

Aftertreatment System

The aftertreatment indicators should illuminate at key on for 2 seconds to test the system. If any of the indicators do not illuminate, the fault must be investigated immediately.

For more information on the illumination of the aftertreatment indicators refer to this Operation and Maintenance Manual, "Selective Catalytic Reduction Warning System".

i08068120

Sensors and Electrical Components

The illustrations within the following sections are typical location of the sensors or electrical components for an industrial engine. Specific engines may appear different due to differences in applications.

NRS – NOx Reduction System

DEF – Diesel Exhaust Fluid

DOC – Diesel Oxidation Catalyst

DPF – Diesel Particulate Filter

SCR – Selective Catalytic Reduction

ECM – Electronic Control Module

NOx – Nitrogen Oxides

904J-E36TA Industrial Engine

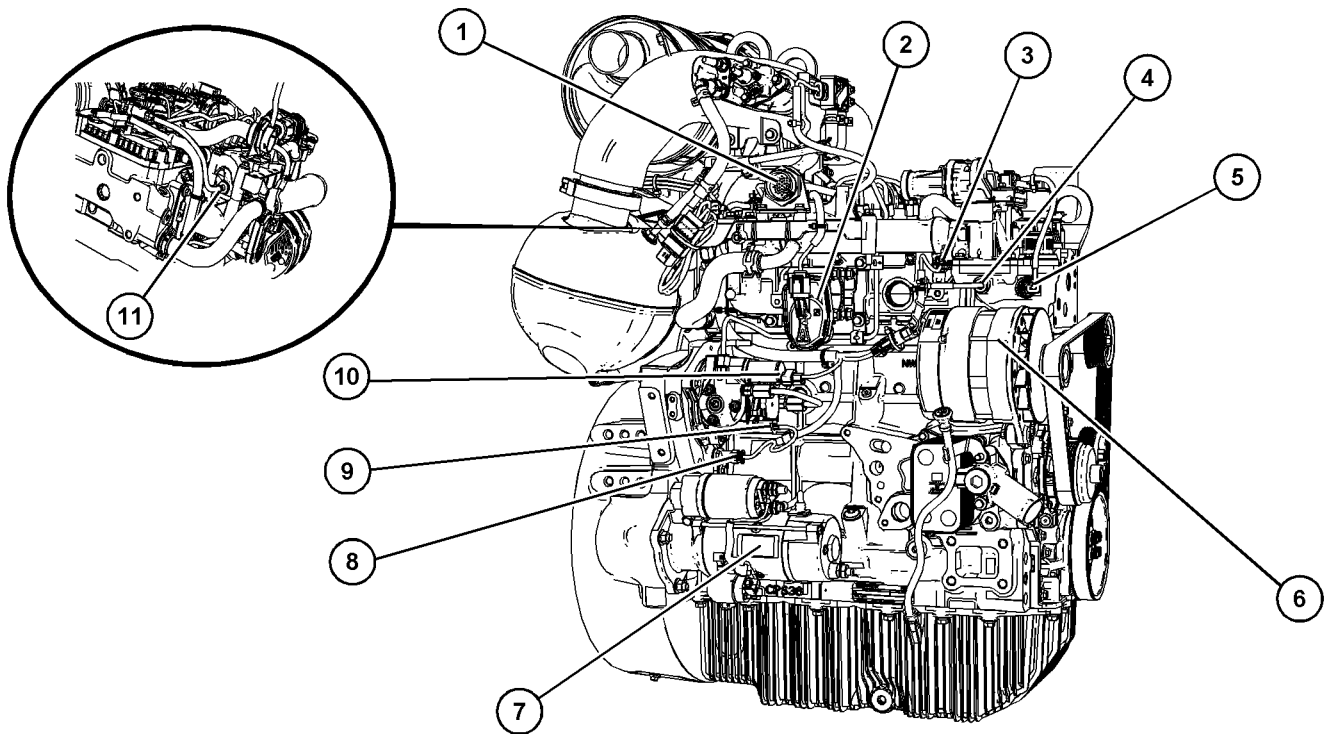

Illustration 55

g06299856

Typical example

- | | | |
|---|----------------------------------|--|
| (1) Engine 47-pin interface connector | (5) Coolant temperature sensor | (10) Control valve for high-pressure fuel pump |
| (2) Inlet throttle valve | (6) Alternator | (11) Temperature sensor post NRS valve |
| (3) Inlet manifold combined pressure and temperature sensor | (7) Starting motor | |
| (4) Temperature sensor before NRS valve | (8) Camshaft speed/timing sensor | |
| | (9) Fuel temperature sensor | |

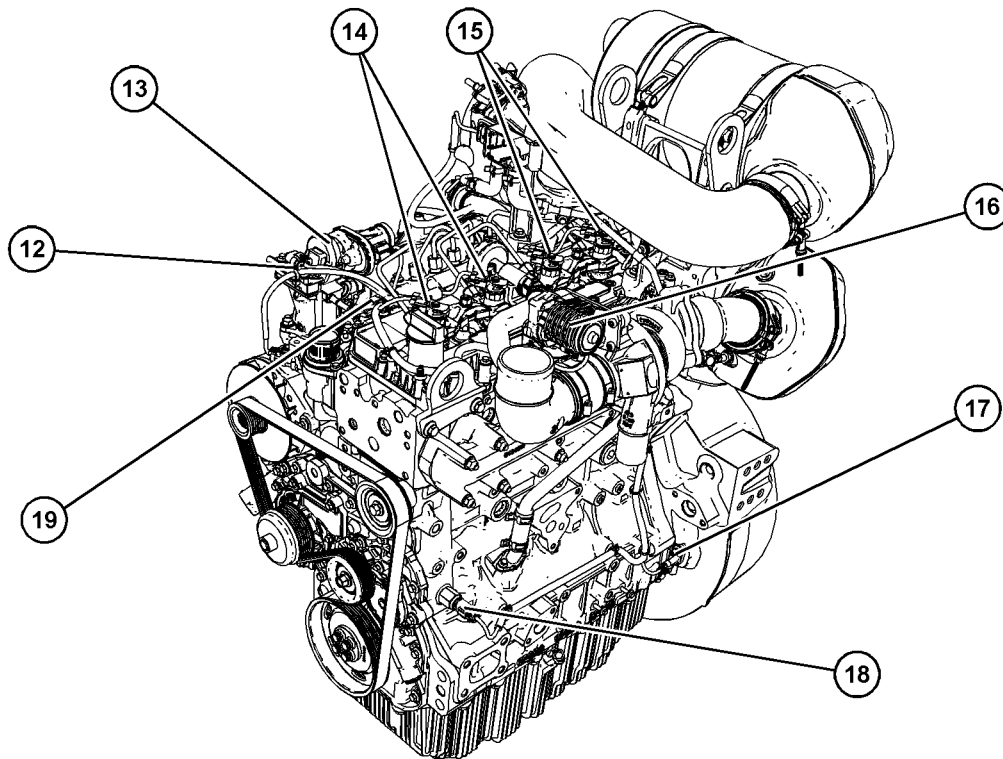

Illustration 56

g06299988

Typical example

(12) Differential pressure sensor
(13) NRS valve
(14) Injector 1 and injector 2

(15) Injector 3 and injector 4
(16) Actuator for turbocharger
(17) Crankshaft speed/timing sensor

(18) Engine oil pressure switch
(19) Fuel rail pressure sensor

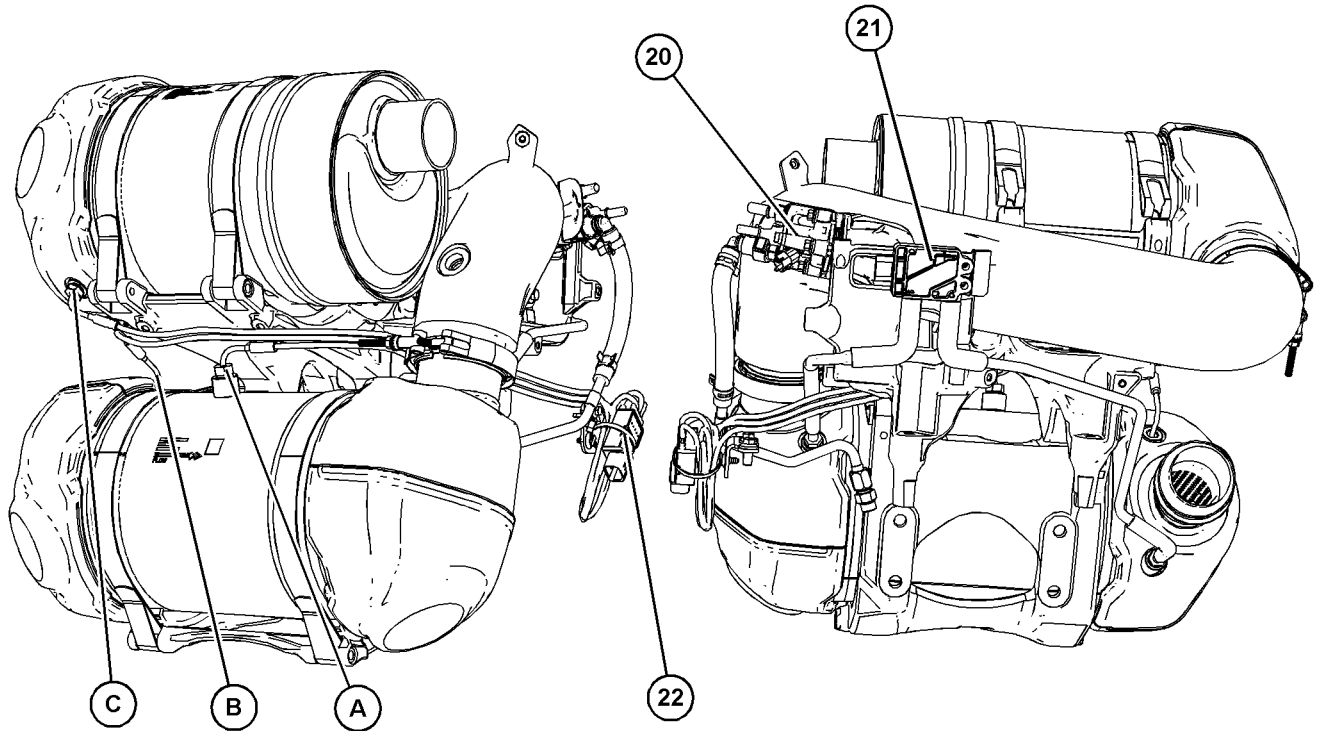

Illustration 57

g06300327

Typical example

- (20) DEF Injector
- (21) DPF Differential pressure sensor

- (22) Temperature sensor controller connection with 3 probes across aftertreatment

- (A) DPF temperature probe
- (B) DOC temperature probe
- (C) SCR temperature probe

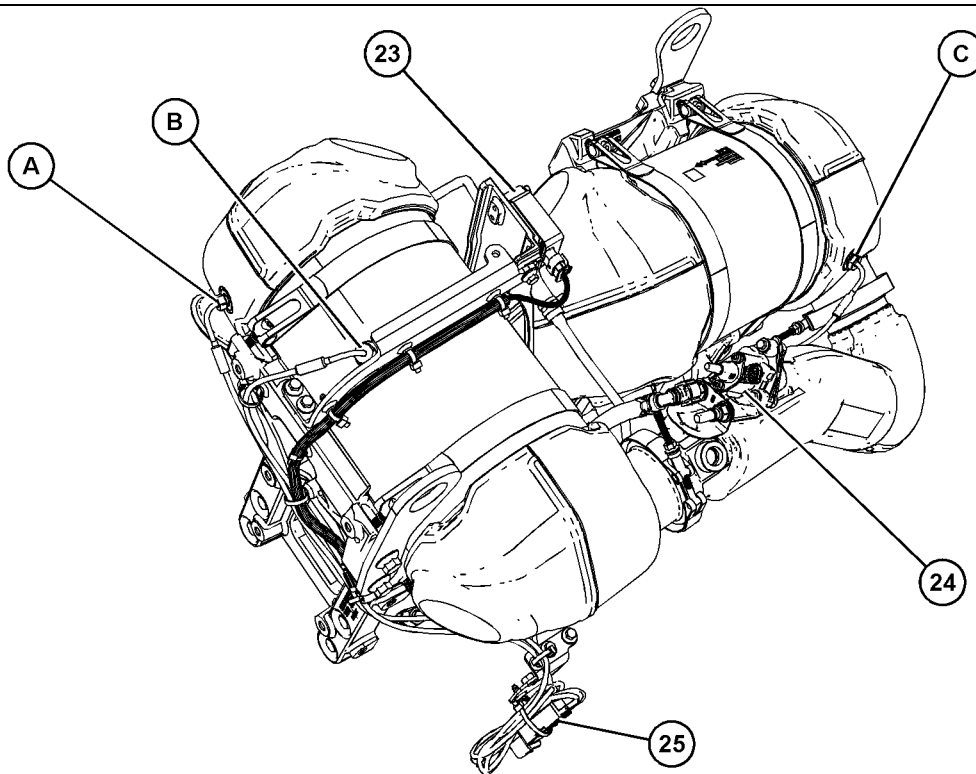

Illustration 58

g06511813

Industrial engine equipped with a balancer

(23) DPF Differential pressure sensor
(24) DEF Injector

(25) Temperature sensor controller
connection with 3 probes across
aftertreatment

(A) DOC temperature probe
(B) DPF temperature probe
(C) SCR temperature probe

904J-E36TA Off Engine Sensors and Electrical Components

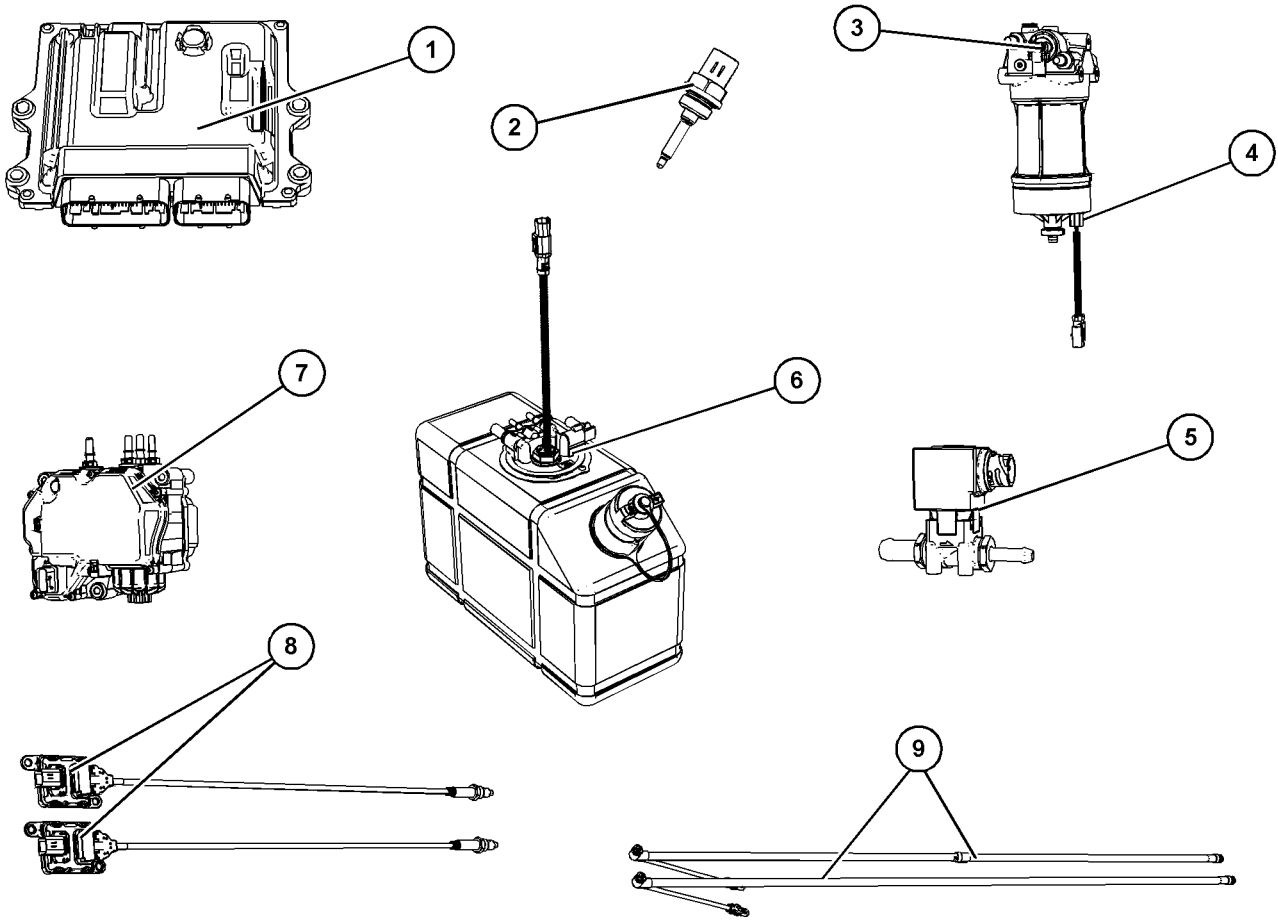

Illustration 59

g06300407

Typical example

- (1) ECM
- (2) Air intake temperature sensor (Air Cleaner), if equipped
- (3) Priming pump

- (4) water in fuel switch
- (5) Coolant diverter valve
- (6) DEF tank level, temperature sensor, and DEF quality sensor

- (7) DEF pump
- (8) NOx sensors
- (9) DEF heated lines

904J-E28T and 904J-E28TA Industrial Engines

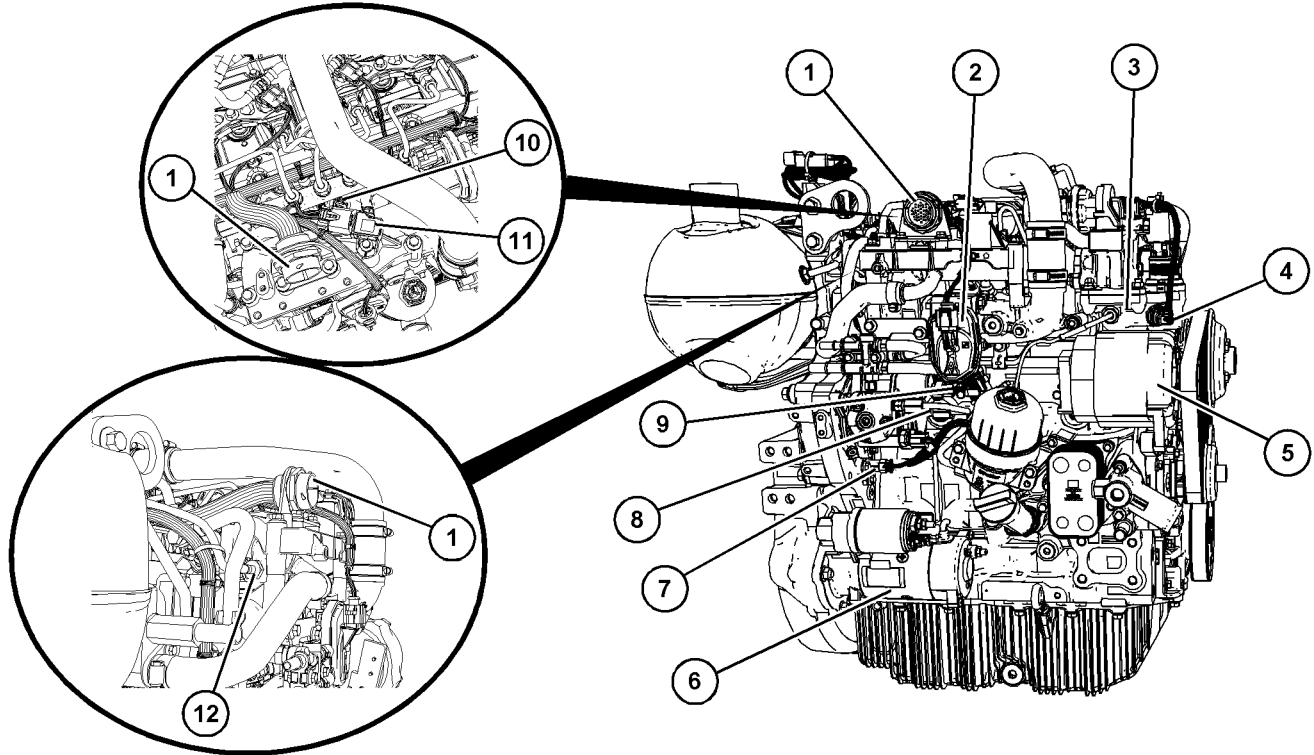

Illustration 60

g06481405

Typical example

- (1) Engine 47-pin interface connector
- (2) Inlet throttle valve
- (3) Temperature sensor pre-NRS valve
- (4) Coolant temperature sensor
- (5) Alternator

- (6) Starting motor
- (7) Camshaft speed/timing sensor
- (8) Fuel temperature sensor
- (9) Control valve for high-pressure fuel pump

- (10) Inlet Manifold Temperature Sensor
- (11) Inlet Manifold Pressure Sensor

- (12) Temperature sensor post NRS valve

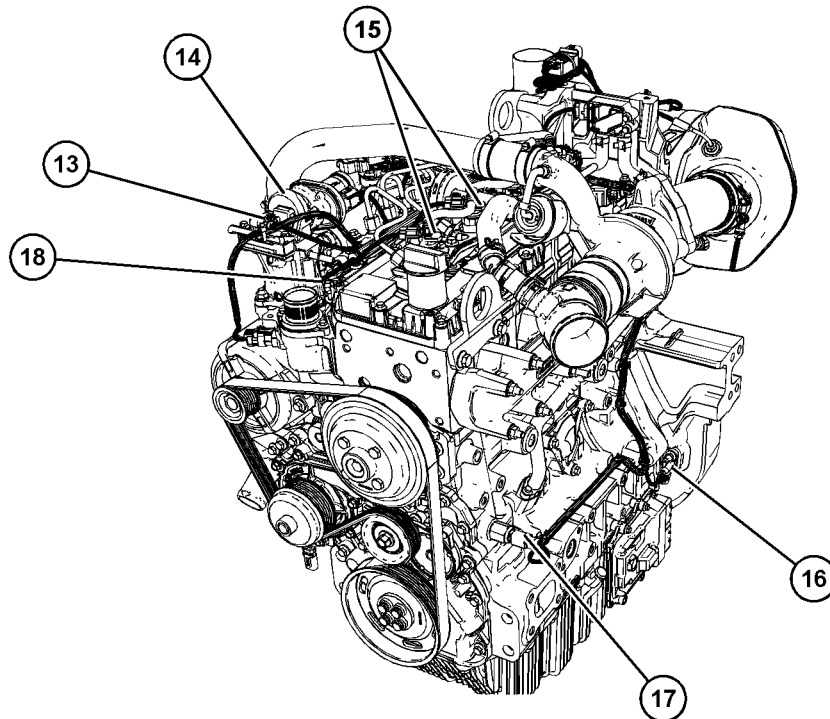

Illustration 61

g06481410

Typical example

(13) NRS Differential pressure sensor
(14) NRS valve

(15) Injector 1 and injector 2 (Injector 3 and
injector 4 not shown)
(16) Crankshaft speed/timing sensor

(17) Engine oil pressure switch
(18) Fuel rail pressure sensor

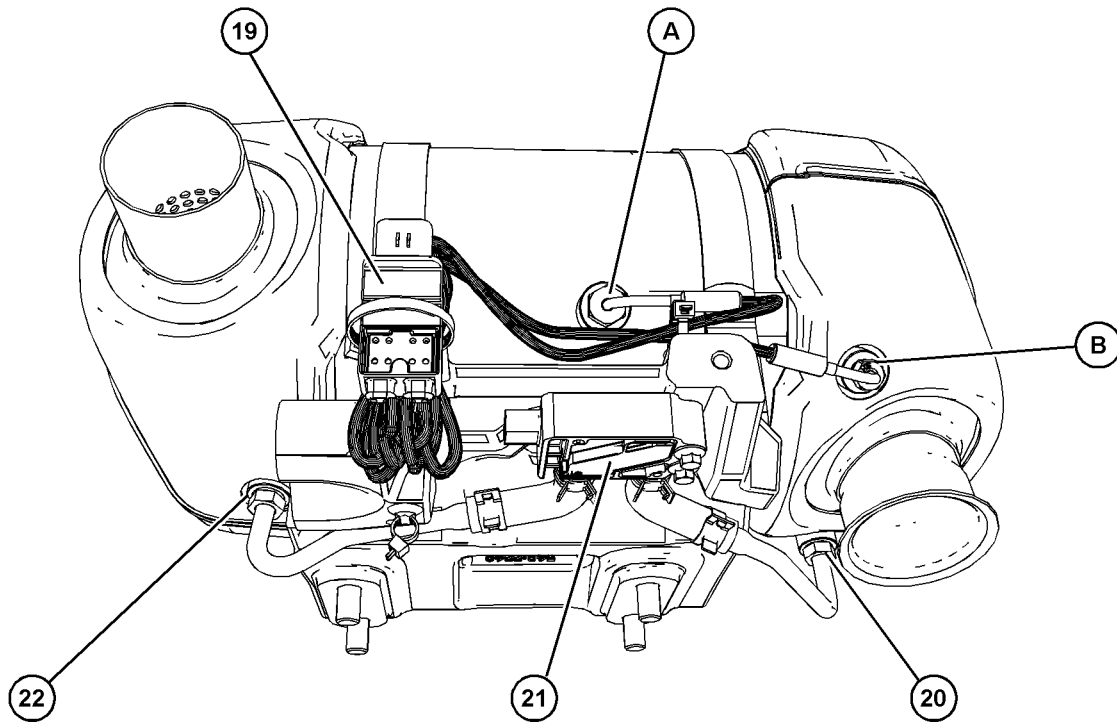

Illustration 62

g06481414

Typical example

(19) Temperature sensor controller with 2 probes across aftertreatment (in transport position)

(20) Tube assembly for Differential pressure
(21) DPF Differential pressure sensor
(22) Tube assembly for Differential pressure

(A) DPF temperature probe
(B) DOC temperature probe

904J-E28T and 904J-E28TA Off Engine Sensors and Electrical Components

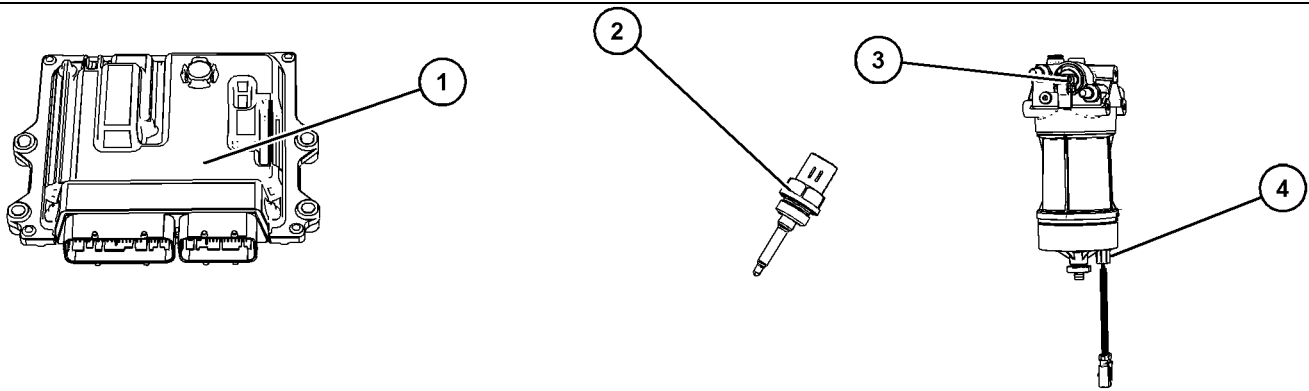

Illustration 63

g06481423

Typical example

(1) ECM

(2) Air intake temperature sensor (Air
Cleaner), If equipped

(3) Priming pump
(4) Water in fuel switch

Engine Diagnostics

i05194988

Self-Diagnostics

Perkins Electronic Engines have the capability to perform a self-diagnostics test. When the system detects an active problem, a diagnostic lamp is activated. Diagnostic codes will be stored in permanent memory in the Electronic Control Module (ECM). The diagnostic codes can be retrieved by using Perkins electronic service tools.

Some installations have electronic displays that provide direct readouts of the engine diagnostic codes. Refer to the manual that is provided by the OEM for more information on retrieving engine diagnostic codes.

Active codes represent problems that currently exist. These problems should be investigated first.

Logged codes represent the following items:

- Intermittent problems
- Recorded events
- Performance history

The problems may have been repaired since the logging of the code. These codes do not indicate that a repair is needed. The codes are guides or signals when a situation exists. Codes may be helpful to troubleshoot problems.

When the problems have been corrected, the corresponding logged fault codes should be cleared.

i03554520

Diagnostic Lamp

A diagnostic lamp is used to indicate the existence of an active fault. A fault diagnostic code will remain active until the problem is repaired. The diagnostic code may be retrieved by using the electronic service tool.

i04907245

Diagnostic Flash Code Retrieval

Use the following procedure to retrieve the flash codes if the engine is equipped with a "DIAGNOSTIC" lamp:

1. Move the keyswitch from the on/off two times within 3 seconds.
2. The shutdown warning lamp will flash once.
3. A flashing YELLOW lamp indicates a 3-digit diagnostic code for the engine. The sequence of flashes represents the system diagnostic message. Count the first sequence of flashes in order to determine the first digit of the flash code. After a two second pause, the second sequence of flashes will identify the second digit of the flash code. After the second pause, the third sequence of flashes will identify the flash code.
4. After the diagnostic codes have been displayed, the shutdown lamp will flash twice and the indicator lamp will start to flash the logged diagnostic codes.
5. After the logged diagnostic codes have been displayed, the shutdown lamp will flash three times in order to indicate that the code sequences have finished.

Note: If there are no diagnostic codes or logged diagnostic codes, the system will flash the code 551.

i05406659

Fault Logging

The system provides the capability of Fault Logging. When the Electronic Control Module (ECM) generates an active diagnostic code, the code will be logged in the memory of the ECM. The codes that have been logged by the ECM can be identified by the electronic service tool. The active codes that have been logged will be cleared when the fault has been rectified or the fault is no longer active. The following logged faults cannot be cleared from the memory of the ECM without using a factory password: Overspeed, low engine oil pressure, high engine coolant temperature, and aftertreatment codes.

i03554534

Engine Operation with Active Diagnostic Codes

If a diagnostic lamp illuminates during normal engine operation, the system has identified a situation that is not within the specification. Use electronic service tools to check the active diagnostic codes.

Note: If the customer has selected “DERATE” and if there is a low oil pressure condition, the Electronic Control Module (ECM) will limit the engine power until the problem is corrected. If the oil pressure is within the normal range, the engine may be operated at the rated speed and load. However, maintenance should be performed as soon as possible.

The active diagnostic code should be investigated. The cause of the problem should be corrected as soon as possible. If the cause of the active diagnostic code is repaired and there is only one active diagnostic code, the diagnostic lamp will turn off.

Operation of the engine and performance of the engine can be limited as a result of the active diagnostic code that is generated. Acceleration rates may be significantly slower. Refer to the Troubleshooting Guide for more information on the relationship between these active diagnostic codes and engine performance.

i01797063

Engine Operation with Intermittent Diagnostic Codes

If a diagnostic lamp illuminates during normal engine operation and the diagnostic lamp shuts off, an intermittent fault may have occurred. If a fault has occurred, the fault will be logged into the memory of the Electronic Control Module (ECM).

In most cases, it is not necessary to stop the engine because of an intermittent code. However, the operator should retrieve the logged fault codes and the operator should reference the appropriate information in order to identify the nature of the event. The operator should log any observation that could have caused the lamp to light.

- Low power
- Limits of the engine speed
- Excessive smoke, etc

This information can be useful to help troubleshoot the situation. The information can also be used for future reference. For more information on diagnostic codes, refer to the Troubleshooting Guide for this engine.

Engine Starting

i08165229

i08171598

Before Starting Engine

Perform the required daily maintenance and other periodic maintenance before the engine is started. Inspect the engine compartment. This inspection can help prevent major repairs later. Refer to the Operation and Maintenance Manual, "Maintenance Interval Schedule" for more information.

- Ensure that the engine has an adequate fuel supply.
- Ensure that the engine has an adequate diesel exhaust fluid supply
- Open the fuel supply valve (if equipped).
- Drain the water separators.

NOTICE

All valves in the fuel return line must be open and fuel supply lines must be open. Damage to the fuel system can occur if fuel lines are closed with the engine in operation.

If the engine has not been started for several weeks, fuel may have drained from the fuel system. Air may have entered the filter housing. Also, when fuel filters have been changed, some air pockets will be trapped in the engine. In these instances, prime the fuel system. Refer to the Operation and Maintenance Manual, "Fuel System - Prime" for more information on priming the fuel system. Also, check that the fuel specification is correct and that the fuel condition is correct. Refer to the Operation and Maintenance Manual, "Fuel Recommendations".

WARNING

Engine exhaust contains products of combustion which may be harmful to your health. Always start and operate the engine in a well ventilated area and, if in an enclosed area, vent the exhaust to the outside.

- Do not start the engine or move any of the controls if there is a "DO NOT OPERATE" warning tag or similar warning tag attached to the start switch or to the controls.
- Reset all the shutoffs or alarm components.
- Ensure that any driven equipment has been disengaged. Minimize electrical loads or remove any electrical loads.

Cold Weather Starting

WARNING

Do not use aerosol types of starting aids such as ether. Such use could result in an explosion and personal injury.

The ability to start the engine will be improved at temperatures below -18°C (0°F) from the use of a jacket water heater or extra battery capacity.

The following items provide a means of minimizing starting problems and fuel problems in cold weather: Engine oil pan heaters, jacket water heaters, fuel heaters, and fuel line insulation.

Use the procedure that follows for cold weather starting.

Note: Do not adjust the engine speed control during start-up. The electronic control module (ECM) will control the engine speed during start-up.

1. Disengage any driven equipment.

Note: During key ON, the indicator lamps will be illuminated for 2 seconds to check the lamp operation. If any of the indicator lamps do not illuminate check the bulb. If any indicator lamps stay illuminated or flash, refer to Troubleshooting, "Indicator Lamp Circuit - Test".

2. Turn the keyswitch to the RUN position. Leave the keyswitch in the RUN position until the warning light for the glow plugs is extinguished.
3. When the warning light for the glow plugs is extinguished, turn the keyswitch to the START position to engage the electric starting motor and crank the engine.

Note: The operating period of the warning light for the glow plugs will change due to the ambient air temperature.

NOTICE

Do not engage the starting motor when flywheel is turning. Do not start the engine under load.

If the engine fails to start within 30 seconds, release the starter switch or button and wait two minutes to allow the starting motor to cool before attempting to start the engine again.

4. Allow the keyswitch to return to the RUN position after the engine starts.

- Repeat step 2 through step 4 if the engine fails to start.

Note: After starting, the engine may be held at low speed for a duration between 1 and 60 seconds to allow engine systems to stabilize. The duration will depend on ambient temperature, time since last run and other factors. The glow plug warning lamp will flash to indicate that the engine has been held at low speed.

- The engine should not be raced to speed up the warm-up process. Allow the engine to idle for 3 to 5 minutes, or allow the engine to idle until the water temperature indicator begins to rise. When idling after the engine has started in cold weather, increase the engine rpm from low idle to 1200 rpm. This operation will warm up the engine more quickly.
- Operate the engine at low load until all systems reach operating temperature. Check the gauges during the warm-up period.

Following a cold start, white vapor can be seen from the tailpipe. This vapor is normal and caused by condensation leaving the exhaust system after warming up. The white vapor should clear following working of the engine.

i08165241

Starting the Engine

Note: Do not adjust the engine speed control during start-up. The electronic control module (ECM) will control the engine speed during start-up.

Starting the Engine

- Disengage any equipment that is driven by the engine.
- Turn the keyswitch to the RUN position. Leave the keyswitch in the RUN position until the warning light for the glow plugs is extinguished.

Note: If the keyswitch has been left in the RUN position for a long period of time without engaging the electric starting motor, turn the keyswitch from the RUN position to the OFF position and then back to the RUN position to reactivate the glow plug preheat stage.

Note: During the key on, the indicator lamps will be illuminated for 2 seconds to check lamp operation. If any of the lamps do not illuminate, check the bulb. If any indicator lamps stay illuminated or flash, refer to Troubleshooting, "Indicator Lamp Circuit - Test".

- When the warning light for the glow plugs is extinguished, turn the keyswitch to the START position to engage the electric starting motor and crank the engine.

Note: The operating period of the warning light for the glow plugs will change due to the temperature of the engine.

NOTICE

Do not engage the starting motor when flywheel is turning. Do not start the engine under load.

If the engine fails to start within 30 seconds, release the starter switch or button and wait two minutes to allow the starting motor to cool before attempting to start the engine again.

- Allow the keyswitch to return to the RUN position after the engine starts.
- Repeat step 2 through step 4 if the engine fails to start.
- After starting, the engine may be held at low speed for a duration between 1 and 60 seconds to allow engine systems to stabilize. The duration will depend on ambient temperature, time since last run and other factors. The glow plug warning light will flash to indicate that the engine is being held at low speed in some applications.

i07944837

Starting with Jump Start Cables

(Do Not Use This Procedure in Hazardous Locations that have Explosive Atmospheres)

WARNING

The connection of battery cables to a battery and the disconnection of battery cables from a battery may cause an explosion which may result in injury or death. The connection and the disconnection of other electrical equipment may also cause an explosion which may result in injury or death. The procedures for the connection and the disconnection of battery cables and other electrical equipment should only be performed in a nonexplosive atmosphere.

WARNING

Improper jump start cable connections can cause an explosion resulting in personal injury.

Prevent sparks near the batteries. Sparks could cause vapors to explode. Do not allow jump start cable ends to contact each other or the engine.

Note: If possible, first diagnose the reason for the starting failure. Refer to Troubleshooting, “Engine Will Not Crank and Engine Cranks But Will Not Start” for further information. Make any necessary repairs. If the engine will not start only due to the condition of the battery, either charge the battery, or start the engine by using another battery with jump-start cables. The condition of the battery can be rechecked after the engine has been switched OFF.

NOTICE

For 904J-E36TA industrial engine, ensure that a 12 VDC or 24 VDC battery source is used to start the engine. For 904J-E28T and 904J-E28TA industrial engines, use a 12 VDC battery source to start the engine. Never attempt to start an engine from an external power source such as electric welding equipment, which has a voltage that is unsuitable for engine starting and will damage the electrical system.

NOTICE

Using a battery source with the same voltage as the electric starting motor. Use **ONLY** equal voltage for jump starting. The use of higher voltage will damage the electrical system.

Do not reverse the battery cables. The alternator can be damaged. Attach ground cable last and remove first.

Turn all electrical accessories OFF before attaching the jump start cables.

Ensure that the main power switch is in the OFF position before attaching the jump start cables to the engine being started.

1. Turn the start switch on the stalled engine to the OFF position. Turn off all the engines accessories.
2. Connect one positive end of the jump-start cable to the positive cable terminal of the discharged battery. Connect the other positive end of the jump-start cable to the positive cable terminal of the electrical source.

3. Connect one negative end of the jump-start cable to the negative cable terminal of the electrical source. Connect the other negative end of the jump-start cable to the engine block or to the chassis ground. This procedure helps to prevent potential sparks from igniting the combustible gases that are produced by some batteries.

Note: The engine ECM must be powered before the starting motor is operated or damage can occur.

4. Start the engine in the normal operating procedure. Refer to this Operation and Maintenance Manual, “Starting the Engine”.
5. Immediately after the engine is started, disconnect the jump-start cables in reverse order.

After jump starting, the alternator may not be able to recharge fully batteries that are severely discharged. The batteries must be replaced or charged to the proper voltage with a battery charger after the engine is stopped. Many batteries which are considered unusable are still rechargeable. Refer to Operation and Maintenance Manual, “Battery - Replace” and Testing and Adjusting Manual, “Battery - Test”.

i08165244

After Starting Engine

After starting, the engine may be held at low speed for a duration between 1 and 60 seconds to allow engine systems to stabilize. Holding the engine speed low is controlled by the Electronic Control Module (ECM). The duration will depend on ambient temperature, time since last run and other factors.

Note: In ambient temperatures from 15° to 20°C (59° to 68°F), the warm-up time is approximately 20 to 30 minutes. In temperatures below 15°C (59°F), additional warm-up time may be required. In temperatures greater than 20° C (68° F), warm-up time may be less.

When the engine idles during warm-up, observe the following conditions:

Do not check the high-pressure fuel lines with the engine or the starting motor in operation. If you inspect the engine in operation, always use the correct inspection procedure to avoid a fluid penetration hazard. Refer to Operation and Maintenance Manual, “General hazard Information”.

- Check for any fluid or air leaks at idle rpm and at one-half full rpm (no load on the engine), before operating the engine under load. This check may not be possible in some applications.

- Allow the engine to idle for 3 to 5 minutes, or allow the engine to idle until the water temperature indicator begins to rise. Check all gauges during the warm-up period.

Constant speed engines should be allowed to operate at low idle for 3 minutes before used at operational speed. If the low idle option is not available, then operate the engine at operational speed with no load for 2 minutes.

Note: Gauge readings should be observed and the data should be recorded frequently while the engine is operating. Comparing the data over time will help to determine normal readings for each gauge. Comparing data over time will also help detect abnormal operating developments. Significant changes in the readings should be investigated.

Engine Operation

i10210738

Engine Operation

Proper operation and maintenance are key factors in obtaining the maximum life and economy of the engine. If the directions in the Operation and Maintenance Manual are followed, costs can be minimized and engine service life can be maximized.

The time that is needed for the engine to reach normal operating temperature can be less than the time taken for a walk-around inspection of the engine.

The engine can be operated at the rated rpm after the engine is started and after the engine reaches operating temperature. The engine will reach normal operating temperature sooner during a low engine speed (rpm) and during a low-power demand. This procedure is more effective than idling the engine at no load. The engine should reach operating temperature in a few minutes.

Avoid excess idling or excess low load operation. Excessive idling or excessive low load operation can cause:

- Carbon build-up
- Increased oil consumption - Higher than expected oil consumption
- Engine slobber ('wetstacking') - Exhaust manifold "slobber" (black oily substance found leaking from exhaust manifold joints)
- Loss of performance
- Harmful deposits in the aftertreatment system (if equipped) - Emissions Aftertreatment systems may lose efficiency or malfunction

These issues are harmful to the engine.

Perkins recommends a minimum load factor of 30% over any 8-hour period of engine operation. Within this period, load should be maintained at >30% for at least 20 continuous minutes, which may help in avoiding any engine operation issues. Perkins also recommends limiting periods of low idle running to avoid engine operation issues.

Gauge readings should be observed and the data should be recorded frequently while the engine is operating. Comparing the data over time will help to determine normal readings for each gauge. Comparing data over time will also help detect abnormal operating developments. Significant changes in the readings should be investigated.

Engine Operation and the Aftertreatment System

The exhaust gases and hydrocarbon particles from the engine first pass through Diesel Oxidation Catalyst (DOC). Some of the gasses and matter are oxidized as the gasses pass through the DOC. The gasses then pass through the Diesel Particulate Filter (DPF). The DPF collects the soot and any ash that is produced by the combustion in the engine. During regeneration, the soot is converted into a gas and the ash remains in the DPF. The gasses finally pass through the Selective Catalytic Reduction (SCR). Before the gasses pass through the SCR, Diesel Exhaust Fluid (DEF) is injected into the gas stream.

The DEF is stored in the DEF tank and is pumped to the DEF injector. The DEF injector is controlled by the ECM. The mixtures of DEF and the exhaust gas pass through the SCR reducing the NOx in the exhaust emissions.

The DPF may require the exhaust gas temperature to rise to remove the soot. If necessary, the throttle valve is operated to help in rising the exhaust temperature.

The engine software will control the amount of DEF that will be required to keep the exhaust emission compliant.

This design of DPF will not require a service maintenance interval. The DPF can be expected to function properly for the useful life of the engine (emissions durability period), as defined by regulation, subject to prescribed maintenance requirements being followed.

A fault code will be active for any DPF system-related issue. Follow the troubleshooting guide to rectify the issue.

If the DPF loses function, or is tampered with in any way, the check engine lamp, and an amber action (if equipped) will illuminate. A fault code will also announce. The lamps and fault code will remain active until the problem is rectified.

NOTICE

The engine and emissions control system shall be operated, used, and maintained in accordance with the instructions provided. Failure to follow the instructions could result in emissions performance that does not meet the requirements applicable to the category of the engine. No deliberate tampering with, or misuse of the engine emissions control system should take place. Prompt action is critical to rectify any incorrect operation, use, or maintenance of the emissions control system.

Carbon Dioxide (CO₂) Emissions Statement

European Union (EU) Stage V emissions regulations require that the value of the CO₂ emissions be reported to the end user. The CO₂ values are reported for each emissions family, this was determined during the EU type approval process for the parent engine. This CO₂ measurement results from testing over a fixed test cycle under laboratory conditions of a(n) (parent) engine representative of the engine type (engine family) and shall not imply or express any guarantee of the performance of a particular engine.

Table 5

Engine Commercial Name	EU Emissions Family	Emissions Family CO ₂ Value (g/kWh)
904J-E28T	NRE4V02.8HPB	852.91
904J-E28TA	NRE4V02.8HPA	839.56
904J-E36TA FW	NRE4V03.6HPA	900.54
904J-E36TA FX	NRE5V03.6HTA	733.12
904J-E36TA ElectropaK	NRE4C03.6HPA	721.4619

i01646335

Engaging the Driven Equipment

1. Operate the engine at one-half of the rated rpm, when possible.
2. Engage the driven equipment without a load on the equipment, when possible.

Interrupted starts put excessive stress on the drive train. Interrupted starts also waste fuel. To get the driven equipment in motion, engage the clutch smoothly with no load on the equipment. This method should produce a start that is smooth and easy. The engine rpm should not increase and the clutch should not slip.

3. Ensure that the ranges of the gauges are normal when the engine is operating at one-half of the rated rpm. Ensure that all gauges operate properly.
4. Increase the engine rpm to the rated rpm. Always increase the engine rpm to the rated rpm before the load is applied.
5. Apply the load. Begin operating the engine at low load. Check the gauges and equipment for proper operation. After normal oil pressure is reached and the temperature gauge begins to move, the engine may be operated at full load. Check the gauges and equipment frequently when the engine is operated under load.

Extended operation at low idle or at reduced load may cause increased oil consumption and carbon buildup in the cylinders. This carbon buildup results in a loss of power and/or poor performance.

i07677865

Fuel Conservation Practices

The efficiency of the engine can affect the fuel economy. Perkins design and technology in manufacturing provides maximum fuel efficiency in all applications. Follow the recommended procedures to attain optimum performance for the life of the engine.

- Avoid spilling fuel.

Fuel expands when it is warmed up. The fuel may overflow from the fuel tank. Inspect fuel lines for leaks. Repair the fuel lines, as needed.

- Be aware of the properties of different fuels. Use only the recommended fuels. Refer to the Operations and Maintenance Manual, "Fuel Recommendations" for further information.
- Avoid unnecessary idling.

Shut off the engine rather than allowing the engine to idle for long periods of time.

- Observe the service indicator frequently. Keep the air cleaner elements clean.

- Ensure that the turbocharger is operating correctly. For more information refer to this Operation and Maintenance Manual, "Turbocharger - Inspect"
- Maintain a good electrical system.

One faulty battery cell will overwork the alternator. This fault will consume excess power and excess fuel.

- The belt should be in good condition. Refer to the Systems Operation, Testing and Adjusting, "V-Belt Test" for further information.
- Ensure that all the connections of the hoses are tight. The connections should not leak.
- Ensure that the driven equipment is in good working order.
- Cold engines consume excess fuel. Utilize heat from the jacket water system and the exhaust system, when possible. Keep cooling system components clean and keep cooling system components in good repair. Never operate the engine without water temperature regulators. All these items will help maintain operating temperatures.

Aftertreatment Operation

i10185380

Selective Catalytic Reduction Warning System

The Selective Catalytic Reduction (SCR) system is a system used to reduce Nitrogen Oxide (NOx) emissions from the engine. Diesel Exhaust Fluid (DEF) is pumped from the DEF tank and is sprayed into the exhaust stream. The DEF reacts with the SCR catalyst to reduce NOx and leaves a nitrogen and water vapor.

The engine and emissions control system shall be operated, used, and maintained in accordance with the instructions provided to the end user to maintain the emissions performance of the engine within the requirements applicable to the category of the engine. No deliberate tampering with, or misuse of the engine emissions control system should take place. In particular regarding deactivating, or not maintaining the SCR system.

NOTICE

Stopping the engine immediately after the engine has been working under load can result in overheating of SCR components.

Refer to the Operation and Maintenance Manual, "Engine Stopping" procedure to allow the engine to cool and to prevent excessive temperatures in the turbocharger housing and the DEF injector.

NOTICE

Allow at least 2 minutes after shutting down the engine before you turn the battery disconnect switch to OFF. Disconnecting the battery power too soon will prevent purging of the DEF lines after the engine is shutdown.

Note: For information on DEF, refer to this Operation and Maintenance Manual, "Fluid Recommendations".

Warning Strategy

The Electronic Control Module (ECM) will be enabled with a world-wide warning strategy.

Warning Indicators

The warning indicators consist of a level gauge for the DEF, a low-level lamp for the DEF, an emission malfunction lamp, and the application stop lamp.

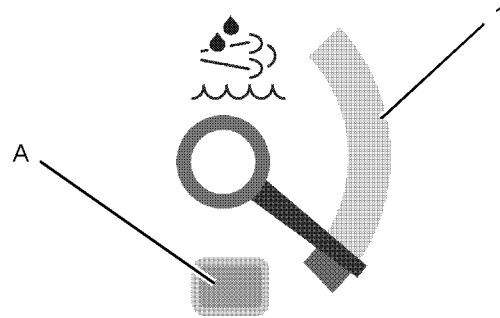

Illustration 64

g03069862

(1) DEF gauge
(A) Low-level warning lamp

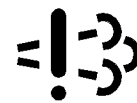

Illustration 65

g02852336

Emission malfunction lamp

Warning Levels

The SCR has three levels of warning. The time that the system will stay at each warning level depends on the fault detected and the type of software enabled.

Any warning should be investigated immediately. Contact your Perkins dealer or your Perkins Distributor if further assistance is required. The system is equipped with an override option. If the override option has been used and the fault still exists, the engine will be locked in de-rate or shutdown mode.

Definitions

- **Self-correct** Fault condition no longer exists. An active fault code will no longer be active.
- **Notification** Action taken by the system to alert the operator of pending Inducement.
- **Inducement** Engine derates, vehicle speed limits, or other actions intended to prompt the operator to repair or maintain the emission control system.

- **Inducement Categories** The Inducements are separated into categories. DEF Levels have inducement fault codes separate from the other inducement categories. DEF level inducements are based on the DEF level, the other inducement categories are based on escalating time. The escalating time inducements will always have an associated fault code along with the inducement fault code. The associated fault is the root cause. The escalating time inducement fault code is just an indicator of what level of inducement the engine is in. The escalating time inducement fault code also indicates how much time remains until the next level of inducement. There are three inducement categories that will trigger an escalating time inducement fault code.
- At Level 3 cycling the keyswitch will give 20 minutes override at full power, before the shutdown or idle is triggered. The emission malfunction lamp will continue to flash.

Note: The associated codes for each of the escalating time categories can be found in Troubleshooting, SCR Warning System Problem.

- **First Time** When an escalating time inducement fault code becomes active for the first time.
- **Repeat occurrence** When any escalating time inducement fault code becomes active again within 40 hours of the first occurrence. Engine must run for 40 hours without tripping any escalating time inducement fault before returning back to first occurrence times.
- **Safe Harbor Mode (Worldwide)** Safe Harbor Mode is a 20 minute engine run time period. Once in level 3 inducement, the operator can perform a key cycle and the engine will enter Safe Harbor Mode. Safe Harbor Mode can only be implemented once. Safe Harbor Mode is not allowed for DEF level inducements with Worldwide configuration.

NOTICE

It is essential to take prompt action to rectify any incorrect operation, use, or maintenance of the emissions SCR control system in accordance with the rectification measures indicated by the warnings listed on the following pages.

World-Wide SCR Warnings

- At Level 1 the emission malfunction lamp will be on solid.
- At Level 2 the emission malfunction lamp will flash.
- At Level 3 the emission malfunction lamp will flash and the stop lamp will activate.
- At Level 3 the engine may shut down, or operate at 1000 Revolutions Per Minute (RPM).

World-Wide Reduced Performance Setting

Table 6

World-Wide Reduced Performance Setting					
Category 1 Fault (Tampering Dosing Interruption and Quality)					
-	Normal operation	Level 1	Level 2	Level 3	Override
Inducement Time First Occurrence	None	2.5 Hours	70 minutes	50 Percent torque Shut down or idle Until fault heals	Cycling the keyswitch will give 20 minutes of full power
The system must be fault free for 40 hours before the system will reset to zero. If the fault is intermittent, and returns within the 40 hours, then the repeat occurrence inducement time will be triggered. The override can only be used once					
Inducement Time Repeat Occurrence	None	5 minutes	75 Percent torque	50 Percent torque Shut down or idle Until fault heals	Cycling the keyswitch will give 20 minutes of full power
Inducement	None	None	None		
Notification	None	Emission malfunction lamp will be on solid	Emission malfunction lamp will flash	Emission malfunction lamp will flash The stop lamp will be on solid	Emission malfunction lamp will flash
Contact your Perkins dealer or your Perkins Distributor at level 1 warning, do not let the fault develop.					

Table 7

World-Wide Reduced Performance Setting					
Category 2 Fault (Non-Tampering Dosing and Interruption)					
-	Normal operation	Level 1	Level 2	Level 3	Override
Inducement Time First Occurrence	None	10 Hours	10 Hours	50 Percent torque Shut down or idle Until fault heals	Cycling the keyswitch will give 20 minutes of full power
The system must be fault free for 40 hours before the system will reset to zero. If the fault is intermittent, and returns within the 40 hours, then the repeat occurrence inducement time will be triggered. The override can only be used once					
Inducement Time Repeat Occurrence	None	None	2 Hours	50 Percent torque Shut down or idle Until fault heals	Cycling the keyswitch will give 20 minutes of full power
Inducement	None	None	75 Percent of torque		
Notification	None	Emission malfunction lamp will be on solid	Emission malfunction lamp will flash	Emission malfunction lamp will flash The stop lamp will be on solid	Emission malfunction lamp will flash
Contact your Perkins dealer or your Perkins Distributor at level 1 warning, do not let the fault develop.					

Table 8

World-Wide Reduced Performance Setting					
Category 3 Fault (Non-Tampering NOx Control Monitoring and Impeded EGR)					
-	Normal operation	Level 1	Level 2	Level 3	Override

(continued)

Operation Section
 Selective Catalytic Reduction Warning System

(Table 8, contd)

Inducement Time First Occurrence	None	36 Hours	64 Hours	50 Percent torque Shut down or idle Until fault heals	Cycling the keyswitch will give 20 minutes of full power
The system must be fault free for 40 hours before the system will reset to zero. If the fault is intermittent, and returns within the 40 hours, then the repeat occurrence inducement time will be triggered. The override can only be used once					
Inducement Time Repeat Occurrence	None	None	5 Hours	50 Percent torque Shut down or idle Until fault heals	Cycling the keyswitch will give 20 minutes of full power
Inducement	None	None	75 Percent of torque		
Notification	None	Emission malfunction lamp will be on solid	Emission malfunction lamp will flash	Emission malfunction lamp will flash The stop lamp will be on solid	Emission malfunction lamp will flash
Contact your Perkins dealer or your Perkins Distributor at level 1 warning, do not let the fault develop.					

World-Wide Reduce Time Setting

Table 9

World-Wide Reduced Time Setting					
Category 1 Fault (Tampering Dosing Interruption and Quality)					
-	Normal operation	Level 1	Level 2	Level 3	Override
Inducement Time First Occurrence	None	2.5 Hours	70 minutes	50 Percent torque Shut down or idle Until fault heals	Cycling the keyswitch will give 20 minutes of full power
The system must be fault free for 40 hours before the system will reset to zero. If the fault is intermittent, and returns within the 40 hours, then the repeat inducement time will be triggered. The override can only be used once.					
Inducement Time Repeat Occurrence	None	5 minutes	5 minutes	50 Percent torque Shut down or idle Until fault heals	Cycling the keyswitch will give 20 minutes of full power
Inducement	None	None	None		
Notification	None	Emission malfunction lamp will be on solid	Emission malfunction lamp will flash	Emission malfunction lamp will flash The stop lamp will activate	Emission malfunction lamp will flash
Contact your Perkins dealer or your Perkins Distributor at level 1 warning, do not let the fault develop.					

Table 10

World-Wide Reduced Time Setting					
Category 2 Fault (Non-Tampering Dosing Interruption)					
-	Normal operation	Level 1	Level 2	Level 3	Override
Inducement Time First Occurrence	None	5 Hours	5 Hours	50 Percent torque Shut down or idle Until fault heals	Cycling the keyswitch will give 20 minutes of full power
The system must be fault free for 40 hours before the system will reset to zero. If the fault is intermittent, and returns within the 40 hours, then the repeat inducement time will be triggered. The override can only be used once.					
Inducement Time Repeat Occurrence	None	None	1 Hour	50 Percent torque Shut down or idle Until fault heals	Cycling the keyswitch will give 20 minutes of full power
Inducement	None	None	None		
Notification	None	Emission malfunction lamp will be on solid	Emission malfunction lamp will flash	Emission malfunction lamp will flash The stop lamp will activate	Emission malfunction lamp will flash
Contact your Perkins dealer or your Perkins Distributor at level 1 warning, do not let the fault develop.					

Table 11

World-Wide Reduced Time Setting					
Category 3 Fault (Non-Tampering NOx Control Monitoring and Impeded EGR)					
-	Normal operation	Level 1	Level 2	Level 3	Override

(continued)

Operation Section
Selective Catalytic Reduction Warning System

(Table 11, contd)

Inducement Time First Occurrence	None	18 Hours	18 Hours	50 Percent torque Shut down or idle Until fault heals	Cycling the keyswitch will give 20 minutes of full power
The system must be fault free for 40 hours before the system will reset to zero. If the fault is intermittent, and returns within the 40 hours, then the repeat inducement time will be triggered. The override can only be used once.					
Inducement Time Repeat Occurrence	None	None	108 Minutes	50 Percent torque Shut down or idle Until fault heals	Cycling the keyswitch will give 20 minutes of full power
Inducement	None	None	None		
Notification	None	Emission malfunction lamp will be on solid	Emission malfunction lamp will flash	Emission malfunction lamp will flash The stop lamp will activate	Emission malfunction lamp will flash
Contact your Perkins dealer or your Perkins Distributor at level 1 warning, do not let the fault develop.					

World-Wide DEF Level Warnings

Two options are available but only one option will be enabled.

- The low-level warning lamp will operate when DEF level reaches the trigger point of below 20 percent.
- At Level 1 the low-level warning lamp in the DEF gauge will illuminate and the emission malfunction lamp will be on solid.
- At Level 2 the low-level warning lamp for the DEF is active and the emission malfunction lamp will flash.
- At Level 3 all level 2 warning lamps are active, plus the stop lamp will become active. The engine will shut down or will only operate at 1000 RPM.

Filling the DEF tank will remove the warning from the system.

Table 12

World-Wide DEF Level Option 1					
-	Normal operation	Initial indication	Level 1	Level 2	Level 3
Inducement Trigger	Above 20 percent	Below 20 percent	Below 13.5 percent	7.5 Percent reading	Empty tank
Inducement	None	None	None	Engine may be de-rated by 25 percent torque	The engine may be de-rated by 50 percent torque. A shutdown or low idle only will be enforced after 5 minutes.
Notification	None	Low-level lamp illuminated	Low-level lamp illuminated Emission malfunction lamp on solid	Low-level lamp illuminated Emission malfunction lamp flashing	Low-level lamp illuminated Emission malfunction lamp flashing Stop lamp on solid

Table 13

World-Wide DEF Level Option 2					
-	Normal operation	Initial indication	Level 1	Level 2	Level 3
Inducement Trigger	Above 20 percent	Below 20 percent	Below 13.5 percent	7.5 Percent reading	3 Percent reading
Inducement	None	None	None	None	The engine may be derated by 50 percent torque A shutdown or low idle only will be enforced after 5 minutes.
Notification	None	Low-level lamp illuminated	Low-level lamp illuminated Emission malfunction lamp on solid	Low-level lamp illuminated Emission malfunction lamp flashing	Low-level lamp illuminated Emission malfunction lamp flashing Stop lamp on solid

Cold Weather Operation

i10073693

Cold Weather Operation

Perkins Diesel Engines can operate effectively in cold weather. During cold weather, the starting and the operation of the diesel engine depends on the following items:

- The type of fuel that is used
- The viscosity of the engine oil
- The operation of the glow plugs
- Optional Cold starting aid
- Battery condition
- Ambient air temperature and altitude
- Parasitic load of the application
- Application hydraulic and transmission oil viscosities

This section will cover the following information:

- Potential problems that are caused by cold-weather operation
- Suggest steps which can be taken to minimize starting problems and operating problems when the ambient air temperature is between 0° to -40 °C (32° to -40 °F).

The operation and maintenance of an engine in freezing temperatures is complex . This complexity is because of the following conditions:

- Weather conditions
- Engine applications

Recommendations from your Perkins dealer or your Perkins distributor are based on past proven practices. The information that is contained in this section provides guidelines for cold-weather operation.

Hints for Cold-Weather Operation

- After starting the engine, the engine speed will be governed for up to a maximum of 60 seconds. After this period, the engine should be operated at low loads until a minimum operating temperature of 80° C (176° F) is achieved.

- Achieving operating temperature will help prevent the intake valves and exhaust valves from sticking.
- The cooling system and the lubrication system for the engine do not lose heat immediately upon shutdown, this means that an engine can be shut down for a period of time and the retained heat within the engine will allow the engine to readily start.
- Install the correct specification of engine lubricant before the beginning of cold weather. Refer to this Operation and Maintenance Manual, "Fluid Recommendations" for the recommended viscosity of oil.
- Check all rubber parts (hoses, fan drive belts) weekly.
- Check all electrical wiring and connections for any fraying or damaged insulation.
- Keep all batteries fully charged and warm by ensuring that the engine is allowed to operate at normal operating temperature.
- Fill the fuel tank at the end of each shift.
- Check the air cleaners and the air intake daily. Check the air intake more often when you operate in snow.
- Ensure that the glow plugs are in working order. Refer to Troubleshooting, "Glow Plug Starting Aid-Test".

WARNING

Personal injury or property damage can result from alcohol or starting fluids.

Alcohol or starting fluids are highly flammable and toxic and if improperly stored could result in injury or property damage.

WARNING

Do not use aerosol types of starting aids such as ether. Such use could result in an explosion and personal injury.

- For jump starting with cables in cold weather, refer to the Operation and Maintenance Manual, "Starting with Jump-Start Cables." for instructions.

Viscosity of the Engine Lubrication Oil

Correct engine oil viscosity is essential. Oil viscosity affects lubrication properties and wear protection that the oil provides for the engine. Refer to this Operation and Maintenance Manual, "Fluid Recommendations" for the recommended viscosity of oil.

At temperatures below -10°C (14°F) damage to engine components can occur if the engine is allowed to operate at high load and speed immediately after starting.

Recommendations for the Coolant

Provide cooling system protection for the lowest expected outside temperature. Refer to this Operation and Maintenance Manual, "Fluid Recommendations" for the recommended coolant mixture.

In cold weather, check the coolant often for the correct glycol concentration to ensure adequate freeze protection.

Engine Block Heaters

Engine block heaters (if equipped) heat the engine jacket water that surrounds the combustion chambers. This heat provides the following functions:

- Startability is improved.
- Warm up time is reduced.

An electric block heater can be activated once the engine is stopped. A block heater can be 120 V ac 600W or 220 V ac 550W. Consult your Perkins dealer or your Perkins distributor for more information.

Idling the Engine

After starting the engine, the engine speed will be governed for a maximum period of 60 seconds. When idling after the engine is started in cold weather, increase the engine rpm from 1000 to 1200 rpm. This idling will warm up the engine more quickly. Maintaining an elevated low idle speed for extended periods will be easier with the installation of a hand throttle. The engine should not be "raced" to speed up the warm-up process.

While the engine is idling, the application of a light load (parasitic load) will help in achieving the minimum operating temperature. The minimum operating temperature is 80°C (176°F).

Recommendations for Coolant Warm Up

Warm up an engine that has cooled below normal operating temperatures due to inactivity. This warm-up should be performed before the engine is returned to full operation. During operation in very cold temperature conditions, damage to engine valve mechanisms can result from engine operation for short intervals. This damage can happen if the engine is started and the engine is stopped many times without being operated to warm up completely.

When the engine is operated below normal operating temperatures, fuel and oil are not burned completely in the combustion chamber. This fuel and oil causes soft carbon deposits to form on the valve stems. Generally, the deposits do not cause problems and the deposits are burned off during operation at normal engine operating temperatures.

When starting and stopping an engine many times without being operated to warm up completely, the carbon deposits become thicker. This starting and stopping can cause the following problems:

- Free operation of the valves is prevented.
- Valves become stuck.
- Pushrods may become bent.
- Other damage to valve train components can result.

For these reasons, when the engine is started, the engine must be operated until the coolant temperature is 80°C (176°F) minimum. Carbon deposit on the valve stems will be kept at a minimum. The free operation of the valves and the valve components will be maintained.

The engine must be warmed thoroughly to keep other engine parts in better condition. The service life of the engine will be generally extended. Lubrication will be improved. There will be less acid and less sludge in the oil. This condition will provide longer service life for the engine bearings, the piston rings, and other parts. However, limit unnecessary idle time to 10 minutes to reduce wear and unnecessary fuel consumption.

The Water Temperature Regulator and Insulated Heater Lines

The engine is equipped with a water temperature regulator. When the engine coolant is below the correct operating temperature, jacket water circulates through the engine cylinder block and into the engine cylinder head. The coolant then returns to the cylinder block via an internal passage that bypasses the valve of the coolant temperature regulator. This return ensures that coolant flows around the engine under cold operating conditions. The water temperature regulator begins to open when the engine jacket water has reached the correct minimum operating temperature. As the jacket water coolant temperature rises above the minimum operating temperature, the water temperature regulator opens further allowing more coolant through the radiator to dissipate excess heat.

The progressive opening of the water temperature regulator operates the progressive closing of the bypass passage between the cylinder block and head. This action ensures maximum coolant flow to the radiator to achieve maximum heat dissipation.

Note: Do not restrict the air flow. Restriction of the air flow can damage the fuel system. Perkins discourages the use of all air flow restriction devices such as radiator shutters. Restriction of the air flow can result in the following: high exhaust temperatures, power loss, excessive fan usage, and reduction in fuel economy.

A cab heater is beneficial in very cold weather. The feed from the engine and the return lines from the cab should be insulated to reduce heat loss to the outside air.

i07944880

Radiator Restrictions

Perkins discourages the use of airflow restriction devices that are mounted in front of radiators. Airflow restriction can cause the following conditions:

- High exhaust temperatures
- Power loss
- Excessive fan usage
- Reduction in fuel economy

Reducing air flow over components will also affect under hood temperatures. Reducing air flow can increase surface temperatures during an aftertreatment regeneration and could affect component reliability.

If an airflow restriction device must be used, the device should have a permanent opening directly in line with the fan hub. The device must have a minimum opening dimension of at least 770 cm² (120 in²).

A centered opening that is directly in line with the fan hub is specified to prevent an interrupted airflow on the fan blades. Interrupted airflow on the fan blades could cause a fan failure.

Perkins recommends a warning device for the inlet manifold temperature and/or the installation of an inlet air temperature gauge.

- For turbocharged, air to air charge cooled engines, the warning device for the inlet manifold temperature should be set at 75 °C (167 °F). The inlet manifold air temperature should not exceed 75 °C (167 °F).
- For turbocharged engines, the warning device for the inlet manifold temperature should be set at 180 °C (356 °F). The inlet manifold air temperature should not exceed 180 °C (356 °F).

Temperatures that exceed these limits can cause power loss and potential engine damage.

i07818744

Fuel and the Effect from Cold Weather

Note: Only use grades of fuel that are recommended by Perkins. Refer to this Operation and Maintenance Manual, "Fluid Recommendations".

Properties of the diesel fuel can have a significant effect on the engine cold start capability. It is critical that the low temperature properties of diesel fuel are acceptable for the minimum ambient temperature the engine is expected to see in operation.

Following properties are used to define fuels low temperature capability:

- Cloud point
- Pour point
- Cold Filter Plugging Point (CFPP)

The cloud point of the fuel is the temperature at which waxes naturally found in the diesel fuel begin to form crystals. The cloud point of the fuel must be below lowest ambient temperature to prevent filters from plugging.

Pour point is the last temperature before the fuel flow stops and waxing of the fuel will start.

Cold Filter Plugging Point (CFPP) is a temperature at which a particular fuel will pass through a standardized filtration device. This CFPP gives an estimate of the lower operability temperature of fuel

Be aware of these properties when diesel fuel is purchased. Consider the average ambient air temperature for the engines application. Engines that are fueled in one climate may not operate well if the engines are shipped to colder climate. Problems can result due to changes in temperature.

Before troubleshooting for low power or for poor performance in the winter, check the fuel for waxing

The following components can provide a means of minimizing fuel waxing problems in cold weather:

- Fuel heaters, which may be an OEM option
- Fuel line insulation, which may be an OEM option

Winter and arctic grades of diesel fuel are available in the countries and territories with severe winters. For more information refer to the Operation and Maintenance Manual, "Fuel For Cold-Weather Operation"

Another important fuel property which can affect cold start and operation of diesel engine is Cetane number. Detail and requirements of this property are given in this Operation and Maintenance Manual, "Fluid Recommendations".

i07486546

Fuel Related Components in Cold Weather

Fuel Tanks

Condensation can form in partially filled fuel tanks. Top off the fuel tanks after you operate the engine.

Fuel tanks should contain some provision for draining water and sediment from the bottom of the tanks.

Some fuel tanks use supply pipes that allow water and sediment to settle below the end of the fuel supply pipe.

Some fuel tanks use supply lines that take fuel directly from the bottom of the tank. If the engine is equipped with this system, regular maintenance of the fuel system filter is important.

Drain the water and sediment from any fuel storage tank at the following intervals: weekly, service intervals and refueling of the fuel tank. Draining will help prevent water and/or sediment from being pumped from the fuel storage tank and into the engine fuel tank.

Fuel Filters

After you change the fuel filter, always prime the fuel system to remove air bubbles from the fuel system. Refer to the Operation and Maintenance Manual in the Maintenance Section for more information on priming the fuel system.

The micron rating and the location of a primary fuel filter is important in cold-weather operation. The primary fuel filter, and the fuel supply line are the most common components that are affected by cold fuel.

Fuel Heaters

Note: The OEM may equip the application with fuel heaters. If so, the temperature of the fuel must not exceed 80° C (176° F) at the fuel transfer pump. The fuel heater should be installed before the electric lift pump.

For more information about fuel heaters (if equipped), refer to the OEM information.

i07944903

Diesel Exhaust Fluid in Cold Weather

Due to the freezing point of Diesel Exhaust Fluid (DEF) the aftertreatment system is equipped with electrically heated DEF lines. The system also has a coolant heated element in the DEF tank and DEF pump.

During periods of weather in which DEF can freeze the application should be stood on level ground when not in use. DEF can start to freeze at -11° C (12.2° F).

Note: At certain angles DEF can cover the DEF filler cap. If the DEF freezes, the DEF tank vent could block. A blocked vent in the DEF tank assembly will cause operational difficulties.

For information on DEF refer to this Operation and Maintenance Manual, "Fluid Recommendations".

Engine Stopping

i07693085

Stopping the Engine

NOTICE

Stopping the engine immediately after the engine has been working under load, can result in overheating and accelerated wear of the engine components.

Avoid accelerating the engine prior to shutting down the engine.

Avoiding hot engine shutdowns will maximize turbo-charger shaft and bearing life. Also, selective catalytic reduction component life.

Note: Individual applications will have different control systems. Ensure that the shutoff procedures are understood. Use the following general guidelines to stop the engine.

1. Remove the load from the engine. Reduce the engine speed to low idle. Allow the engine to idle for 5 minutes to cool the engine.
2. Stop the engine after the cool down period according to the shutoff system on the engine and turn the ignition keyswitch to the OFF position. If necessary, refer to the instructions that are provided by the OEM.

Note: In some applications the engine will continue to operate after the keyswitch is turned to the OFF position. The engine will operate for a short time to allow engine components to cool.

3. Allow at least 2 minutes after the engine has stopped before you turn the battery disconnect switch to OFF. Disconnecting the battery power too soon will prevent purging of the DEF fluid lines after the engine is shut down. Also, during the 2 minutes the engine electronic control module is active, storing information from the engine and aftertreatment sensors.

Delayed Engine Shutdown (if Equipped)

The delayed engine shutdown allows the engine to run for a time after the engine start switch is turned to the OFF position to cool the system components. The engine start switch key may be removed.

Note: There may be regulations that define the requirements for the operator and/or support personnel to be present when the engine is running.

WARNING

Leaving the machine unattended when the engine is running may result in personal injury or death. Before leaving the machine operator station, neutralize the travel controls, lower the work tools to the ground and deactivate all work tools, and place the lever for the hydraulic lockout control in the LOCKED position.

Leaving the engine unattended while running may result in property damage in the event of a malfunction.

Note: An authorized dealer can change the maximum run time value up to 30 minutes but the default setting is 10 minutes.

An override can be enabled so that the delayed engine shutdown will not operate. Overriding delayed engine shutdown may reduce engine and system component life. The override is operated by the keyswitch.

At any time during a delayed engine shutdown, the engine start switch may be turned to the ON position. The engine may be placed back into service.

i05195199

Emergency Stopping

NOTICE

Emergency shutoff controls are for EMERGENCY use ONLY. DO NOT use emergency shutoff devices or controls for normal stopping procedure.

The OEM may have equipped the application with an emergency stop button. For more information about the emergency stop button, refer to the OEM information.

Ensure that any components for the external system that support the engine operation are secured after the engine is stopped.

i07486528

After Stopping Engine

Note: Before you check the engine oil, do not operate the engine. Wait for at least 30 minutes after the engine has stopped to allow the engine oil to return to the oil pan.

⚠ WARNING

Contact with high pressure fuel may cause fluid penetration and burn hazards. High pressure fuel spray may cause a fire hazard. Failure to follow these inspection, maintenance and service instructions may cause personal injury or death.

- Diesel Exhaust Fluid (DEF) purge, do not disconnect the battery disconnect switch until the DEF purge has been completed. The procedure is automatically controlled and will take approximately 2 minutes.
- After the engine has stopped, you must wait for 10 minutes to allow the fuel pressure to be purged from the high-pressure fuel lines before any service or repair is performed on the engine fuel lines. If necessary, perform minor adjustments. Repair any leaks from the low-pressure fuel system and from the cooling, lubrication, or air systems. Replace any high-pressure fuel line that has leaked. Refer to Disassembly and Assembly Manual, "Fuel Injection Lines - Install".
- Check the crankcase oil level. Maintain the oil level between the "MIN" mark and the "MAX" mark on the engine oil level gauge.
- If the engine is equipped with a service hour meter, note the reading. Perform the maintenance that is in the Operation and Maintenance Manual, "Maintenance Interval Schedule".
- Fill the fuel tank, to help prevent accumulation of moisture in the fuel. Do not overfill the fuel tank.
- Fill the DEF tank, a low level of DEF in the tank can result in engine de-rate.

NOTICE

Only use antifreeze/coolant mixtures recommended in this Operation and Maintenance Manual, "Refill Capacities and Recommendations" topic or in this Operation and Maintenance Manual, "Fluid Recommendations" topic. Failure to do so can cause engine damage.

⚠ WARNING

Pressurized System: Hot coolant can cause serious burns. To open the cooling system filler cap, stop the engine and wait until the cooling system components are cool. Loosen the cooling system pressure cap slowly in order to relieve the pressure.

- Check the coolant for correct antifreeze protection and the correct corrosion protection. Add the correct coolant/water mixture, if necessary.
 - Perform all required periodic maintenance on all driven equipment. This maintenance is outlined in the instructions from the OEM.
- Allow the engine to cool. Check the coolant level.

Maintenance Section

Refill Capacities

i10204668

Refill Capacities

Lubrication System for Engines Equipped With a Standard Oil Pan

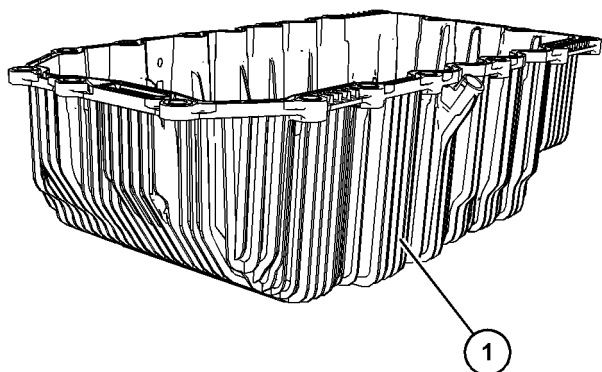

Illustration 66

g06511838

Typical example
 (1) Standard Oil Pan

OEM – Original Equipment Manufacturer

The refill capacities for the engine crankcase reflect the approximate capacity of the crankcase or sump plus standard oil filters. Auxiliary oil filter systems will require extra oil. Refer to the OEM specifications for the capacity of the auxiliary oil filter. Refer to the Operation and Maintenance Manual, “Maintenance Section” for more information on Lubricant Specifications.

Table 14

904J-E36TA Industrial Engine Refill Capacities	
Compartment or System	Capacity
Crankcase Oil Sump ⁽¹⁾	8 to 10.6 L (2.11360 to 2.80052 US gal)

⁽¹⁾ These values are the approximate capacities for the crankcase oil sump which includes the standard factory installed oil filters. Engines with auxiliary oil filters will require extra oil. Refer to the OEM specifications for the capacity of the auxiliary oil filter. The design of the oil pan can change the oil capacity of the oil pan.

Table 15

904J-E28T and 904J-E28TA Industrial Engines Refill Capacities	
Compartment or System	Capacity
Crankcase Oil Sump ⁽¹⁾	7.5 to 8.8 L (1.98150 to 2.32496 US gal)

⁽¹⁾ These values are the approximate capacities for the crankcase oil sump which includes the standard factory installed oil filters. Engines with auxiliary oil filters will require extra oil. Refer to the OEM specifications for the capacity of the auxiliary oil filter. The design of the oil pan can change the oil capacity of the oil pan.

Lubrication System for Engines Equipped With a Balancer Oil Pan

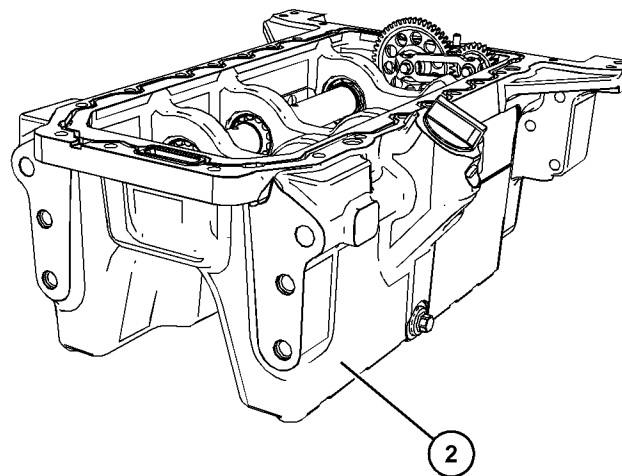

Illustration 67

g06511850

Typical example
 (2) Oil Pan with a balancer

OEM – Original Equipment Manufacturer

The refill capacities for the engine crankcase reflect the approximate capacity of the crankcase or sump plus standard oil filters. Auxiliary oil filter systems will require extra oil. Refer to the OEM specifications for the capacity of the auxiliary oil filter. Refer to the Operation and Maintenance Manual, "Maintenance Section" for more information on Lubricant Specifications.

Note: During engine oil changes both sides of the engine oil pan must be drained of lubricant.

Table 16

904J-E36TA Industrial Engine With a Balancer Oil Pan Refill Capacities	
Compartment or System	Capacity
Crankcase Oil Sump ⁽¹⁾	8.5 to 10 L (2.246 to 2.642 US gal)

⁽¹⁾ These values are the approximate capacities for the crankcase oil sump which includes the standard factory installed oil filters. Engines with auxiliary oil filters will require extra oil. Refer to the OEM specifications for the capacity of the auxiliary oil filter. The design of the oil pan can change the oil capacity of the oil pan.

Cooling System

Refer to the OEM specifications for the External System capacity. This capacity information will be needed to determine the amount of coolant/antifreeze that is required for the Total Cooling System.

Table 17

904J-E36TA Industrial Engine Refill Capacities	
Compartment or System	Capacity
Engine Only	4.3 L (1.136 US gal)
External System Per OEM ⁽¹⁾	

⁽¹⁾ The External System includes a radiator or an expansion tank with the following components: heat exchanger and piping. Refer to the OEM specifications. Enter the value for the capacity of the External System in this row.

Table 18

904J-E28T and 904J-E28TA Industrial Engines Refill Capacities	
Compartment or System	Capacity
Engine Only	3.9 L (1.03038 US gal)
External System Per OEM ⁽¹⁾	

⁽¹⁾ The External System includes a radiator or an expansion tank with the following components: heat exchanger and piping. Refer to the OEM specifications. Enter the value for the capacity of the External System in this row.

Industrial Open Power Unit (IOPU)

Table 19

904J-E36TA IOPU Refill Capacities	
Compartment or System	Capacity
Engine Only	4.3 L (1.136 US gal)
Radiator	8.7 L (2.3 US gal)
Total coolant capacity	11.5 to 13.2 L (3.04 to 3.49 US gal)

Table 20

904J-E28T IOPU Refill Capacities	
Compartment or System	Capacity
Engine Only	3.9 L (1.03 US gal)
Radiator	8.9 L (2.35 US gal)
Total coolant capacity	10.6 to 12.2 L (2.80 to 3.22 US gal)

904J-E36TA ElectropaK

Table 21

904J-E36TA ElectropaK Refill Capacities	
Compartment or System	Capacity
Engine Only	4.3 L (1.136 US gal)
Radiator	12.3 L (3.24966 US gal)
Total coolant capacity	

DEF System

DEF – Diesel Exhaust Fluid

Table 22

DEF Tank Capacity
19 L (5 US gal) ⁽¹⁾
11.5 L (3.0 US gal) ⁽²⁾

⁽¹⁾ OEM tank size shape, and capacities could be different.

(continued)

(Table 22, contd)

(2) OEM tank size shape, and capacities could be different.

i07380477

Fluid Recommendations

General Lubricant Information

Because of government regulations regarding the certification of exhaust emissions from the engine, the lubricant recommendations must be followed.

- API _____ American Petroleum Institute
- SAE _____ Society Of Automotive Engineers Inc.
- ACEA _____ Association des Constructers European Automobiles.
- ECF-3 _____ Engine Crankcase Fluid

Licensing

The Engine Oil Licensing and Certification System by the American Petroleum Institute (API) and the Association des Constructers European Automobiles (ACEA) is recognized by Perkins. For detailed information about this system, see the latest edition of the "API publication No. 1509". Engine oils that bear the API symbol are authorized by API.

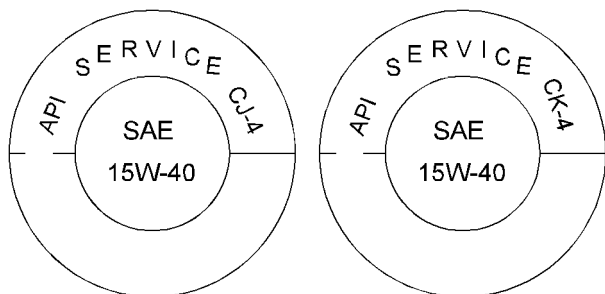

Illustration 68

g06404013

Typical API symbols

Terminology

Certain abbreviations follow the nomenclature of "SAE J754". Some classifications follow "SAE J183" abbreviations, and some classifications follow the "EMA Recommended Guideline on Diesel Engine Oil". In addition to Perkins definitions, there are other definitions that will be of assistance in purchasing lubricants. Recommended oil viscosities can be found in this publication, "Fluid Recommendations/ Engine Oil" topic (Maintenance Section).

Engine Oil

Commercial Oils

Perkins recommends use of Perkins Diesel Engine Oil for all Perkins engines. Perkins unique oil formulations have been developed to provide full performance and maximum service life of your engine, and in tests have been shown to provide superior protection. Available in suitable API classifications to meet the emissions requirements and performance of your engine, Refer to 23 for the correct oil specification for your engine. Consult your Perkins distributor for more information on these multi-grade oils.

NOTICE

Perkins require the use of the following specification of engine oil. Failure to use the appropriate specification of engine oil will reduce the life of your engine. Failure to use the appropriate specification of engine oil will also reduce the life of your aftertreatment system.

Table 23

Classifications for the 904J Industrial Engine
Oil Specification
API CJ-4 API CK-4 ACEA E9 ECF-3

API CJ-4, API CK-4, and ACEA E9 oil categories have the following chemical limits:

- 0.1 percent maximum sulfated ash
- 0.12 percent maximum phosphorous
- 0.4 percent maximum sulfur

The chemical limits were developed to maintain the expected life of the engine aftertreatment system. The performance of the engine aftertreatment system can be adversely affected if oil that is not specified in table 23 is used.

The life of your Aftertreatment system is defined by the accumulation of ash on the surface of the filter. Ash is the inert part of the particulate matter. The system is designed to collect this particulate matter. There is a very small percentage of particulate matter that is left behind as the soot is burnt. This matter will eventually block the filter, causing loss of performance and increased fuel consumption. Most of the ash comes from the engine oil which is gradually consumed during normal operation. This ash is passed through the exhaust. To meet the designed life of the product, the use of the appropriate engine oil is essential. The oil specification that is listed in table 23 has low ash content.

Maintenance intervals for engines that use biodiesel – The oil change interval can be adversely affected by the use of biodiesel. Use oil analysis to monitor the condition of the engine oil. Use oil analysis also to determine the oil change interval that is optimum.

Note: API FA-4 oil is designed for use in selected on-highway applications and is NOT designed to support off-road applications, including Perkins Engines. DO NOT use API FA-4 oil for Perkins engines. These engine oils are not approved by Perkins and these engine oils must not be used: CC, CD, CD-2, CF-4, CG-4, CH-4, and CI-4.

Lubricant Viscosity Recommendations for Direct Injection (DI) Diesel Engines

The correct SAE viscosity grade of oil is determined by the minimum ambient temperature during cold engine start-up, and the maximum ambient temperature during engine operation.

Refer to illustration 69 (minimum temperature) to determine the required oil viscosity for starting a cold engine.

Refer to illustration 69 (maximum temperature) to select the oil viscosity for engine operation at the highest ambient temperature that is anticipated.

Generally, use the highest oil viscosity that is available to meet the requirement for the temperature at start-up.

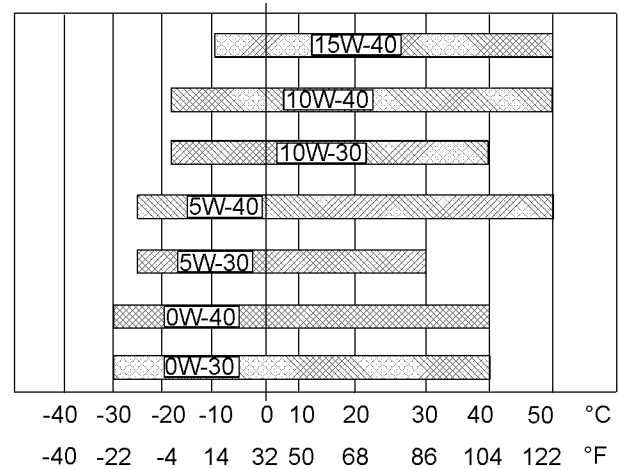

Illustration 69

g03329707

Lubricant Viscosities

Supplemental heat is recommended for cold soaked starts below the minimum ambient temperature. Supplemental heat may be required for cold soaked starts that are above the minimum temperature that is stated, depending on the parasitic load and other factors. Cold soaked starts occur when the engine has not been operated for a period of time. This interval will allow the oil to become more viscous due to cooler ambient temperatures.

Aftermarket Oil Additives

Perkins does not recommend the use of aftermarket additives in oil. The use of aftermarket additives is not necessary to achieve the engines maximum service life or rated performance. Fully formulated, finished oils consist of base oils and of commercial additive packages. These additive packages are blended into the base oils at precise percentages to help provide finished oils with performance characteristics that meet industry standards.

There are no industry standard tests that evaluate the performance or the compatibility of aftermarket additives in finished oil. Aftermarket additives may not be compatible with the finished oils additive package, which could lower the performance of the finished oil. The aftermarket additive could fail to mix with the finished oil. This failure could produce sludge in the crankcase. Perkins discourages the use of aftermarket additives in finished oils.

To achieve the best performance from a Perkins engine, conform to the following guidelines:

- See the appropriate "Lubricant Viscosities". Refer to the illustration 69 to find the correct oil viscosity grade for your engine.

- At the specified interval, service the engine. Use new oil and install a new oil filter.
- Perform maintenance at the intervals that are specified in the Operation and Maintenance Manual, "Maintenance Interval Schedule".

Oil Analysis

Some engines may be equipped with an oil sampling valve. If oil analysis is required, the oil sampling valve is used to obtain samples of the engine oil. The oil analysis will complement the preventive maintenance program.

The oil analysis is a diagnostic tool that is used to determine oil performance and component wear rates. Contamination can be identified and measured by using oil analysis. The oil analysis includes the following tests:

- The Wear Rate Analysis monitors the wear of the engines metals. The amount of wear metal and type of wear metal that is in the oil is analyzed. The increase in the rate of engine wear metal in the oil is as important as the quantity of engine wear metal in the oil.
- Tests are conducted to detect contamination of the oil by water, glycol, or fuel.
- The Oil Condition Analysis determines the loss of the oils lubricating properties. An infrared analysis is used to compare the properties of new oil to the properties of the used oil sample. This analysis allows technicians to determine the amount of deterioration of the oil during use. This analysis also allows technicians to verify the performance of the oil according to the specification during the entire oil change interval.

i07477709

Fluid Recommendations (General Fuel Information)

• Glossary

- ISO _____International Standards Organization
- ASTM _____American Society for Testing and Materials
- HFRR _____High Frequency Reciprocating Rigfor Lubricity testing of diesel fuels
- FAME _____Fatty Acid Methyl Esters
- CFR _____Co-ordinating Fuel Research
- ULSD _____Ultra Low Sulfur Diesel

- RME _____Rape Methyl Ester
- SME _____Soy Methyl Ester
- EPA _____Environmental Protection Agency of the United States
- PPM _____Parts Per Million
- DPF _____Diesel Particulate Filter
- v/v _____(volume of solute)/(volume of solution)
- CFPP _____Cold Filter Plugging Point
- BTL _____Biomass to liquid
- GTL _____Gas to liquid
- CTL _____Coal to liquid
- HVO _____Hydrotreated Vegetable Oil

General Information

NOTICE

Every attempt is made to provide accurate, up-to-date information. By use of this document you agree that Perkins Engines Company Limited is not responsible for errors or omissions.

NOTICE

These recommendations are subject to change without notice. Contact your local Perkins distributor for the most up-to-date recommendations.

Diesel Fuel Requirements

Perkins is not in a position to continuously evaluate and monitor all worldwide distillate diesel fuel specifications that are published by governments and technological societies.

The "Perkins Specification for Distillate Diesel Fuel" provides a known reliable baseline to judge the expected performance of distillate diesel fuels that are derived from conventional sources.

Satisfactory engine performance depends on the use of a good quality fuel. The use of a good quality fuel will give the following results: long engine life and acceptable exhaust emissions levels. The fuel must meet the minimum requirements that are stated in the table 24 .

NOTICE

The footnotes are key part of the Perkins "Specification for Distillate Diesel Fuel" Table. Read ALL of the footnotes.

Table 24

"Perkins Specification for Distillate Diesel Fuel"				
Property	UNITS	Requirements	"ASTM" Test	"ISO/Other" Test
Aromatics	%Volume	35% maximum	"D1319"	"ISO 3837"
Ash	%Weight	0.01% maximum	"D482"	"ISO 6245"
Carbon Residue on 10% Bottoms	%Weight	0.20% maximum	"D524"	"ISO 4262"
Cetane Number ⁽¹⁾	-	40 minimum in North America 45 minimum in European Union	"D613 or D6890"	"ISO 5165"
Cloud Point	°C	The cloud point must not exceed the lowest expected ambient temperature.	"D2500"	"ISO 3015"
Copper Strip Corrosion	-	No. 3 maximum	"D130"	"ISO 2160"
Distillation	°C	50% at 250° C (482° F) minimum 90% at 350° C (662° F) maximum	"D86"	"ISO 3405"
Density at 15 °C (59 °F) ⁽²⁾	kg/M ³	800 minimum and 860 maximum	No equivalent test	"ISO 3675""ISO 12185"
Flash Point	°C	legal limit	"D93"	"ISO 2719"
Thermal Stability	-	Minimum of 80% reflectance after aging for 180 minutes at 150 °C (302 °F)	"D6468"	No equivalent test
Pour Point	°C	6 °C (42.8 °F) minimum below ambient temperature	"D97"	"ISO 3016"
Sulfur ⁽³⁾	%mass	0.0010 % Stage V Europe and 0.0015 % Tier 4 Final North America	"D5453"	"ISO 20846"
Kinematic Viscosity ⁽⁴⁾	MM ² /S (cSt)	The viscosity of the fuel that is delivered to the fuel injection pump. 1.4 minimum and 4.5 maximum	"D445"	"ISO 3405"
Water and sediment	% weight	0.05% maximum	"D1796"	"ISO 3734"
Water	% weight	0.02% maximum	"D1744"	No equivalent test
Sediment	% weight	0.05% maximum	"D473"	"ISO 3735"
Gums and Resins ⁽⁵⁾	mg/100mL	10 mg per 100 mL maximum	"D381"	"ISO 6246"
Lubricity corrected wear scar diameter at 60 °C (140 °F). ⁽⁶⁾	mm	0.52 maximum	"D6079"	"ISO 12156-1"
Fuel Cleanliness ⁽⁷⁾	-	"ISO 18/16/13"	"D7619"	"ISO 4406"
Trace Metals ⁽⁸⁾	mg/mg	Max 1 or non-detectable	"D7111"	
Oxidation Stability	g/m ³	Max 25	"D2274"	"ISO 12205"
	Hours ⁽⁹⁾	Min 20		"EN 15751"

(continued)

Maintenance Section
General Fuel Information

(Table 24, contd)

- (1) A fuel with a higher cetane number than 45 is recommended to operate at a higher altitude in cold weather
- (2) Density range allowed includes summer and winter diesel fuel grades.
- (3) Follow the national, state, local, and other governing authorities for guidance concerning the fuel requirements in your area. In Europe for non-road Stage V emissions regulations require sulfur free diesel fuels with sulphur content less than 0.0010 percent (10 PPM) (mg/kg)). In the USA, EPA regulations require use of ULSD fuel with less than 0.0015 percent (15 PPM) (mg/kg)) sulfur content. Use of diesel fuel with higher than 15 PPM sulphur limit in these engines will harm or permanently damage emissions control systems and/or shorten their service interval.
- (4) The values of the fuel viscosity are the values as the fuel is delivered to the fuel injection pumps. Fuel should also meet the minimum viscosity requirement and the fuel should meet the maximum viscosity requirements at 40 °C (104 °F) of either the "ASTM D445" test method or the "ISO 3104" test method. If a fuel with a low viscosity is used, cooling of the fuel may be required to maintain "1.4 cSt" or greater viscosity at the fuel injection pump. Fuels with a high viscosity might require fuel heaters to lower the viscosity to "1.4 cSt" at the fuel injection pump.
- (5) Follow the test conditions and procedures for gasoline (motor).
- (6) The lubricity of a fuel is a concern with low sulfur and ultra low sulfur fuel. Fuel with higher wear scar diameter than 0.52 mm (0.0205 inch) will lead to reduced service life and premature failure of the fuel system. Refer to the lubricity section of this "Operation and Maintenance Manual" Fluid Recommendations for more information.
- (7) Recommended cleanliness level for fuel as dispensed into machine or engine fuel tank is "ISO 18/16/13" or cleaner as per "ISO 4406". Refer to the "Contamination Control Recommendations for Fuels."
- (8) Examples of trace metals include but not limited to Cu, Fe, Mn, Na, P, Pb, Si, and Zn. Use of metal-based additives is not allowed.
- (9) Additional limit for fuel containing FAME. Fuel containing more than 2% v/v FAME must meet both tests.

Note: The owner and the operator of the engine has the responsibility of using the fuel that is prescribed by the EPA and other appropriate regulatory agencies.

NOTICE

Operating with fuels that do not meet the Perkins recommendations can cause the following effects: Starting difficulty, reduced fuel filter service life, poor combustion, deposits in the fuel injectors, significantly reduce service life of the fuel system. Also, the creation of deposits in the combustion chamber and reduced service life of the engine.

NOTICE

The Perkins 904J series of diesel engine must be operated using Ultra Low Sulfur Diesel. The sulphur content of this fuel must be lower than 15 PPM. This fuel complies with the emissions regulations that are prescribed by the Environmental Protection Agency of the United States. In Europe, sulfur free diesel fuels with sulphur content less than 0.0010 percent (10 PPM) (mg/kg)) is required by regulation for use in engines certified to EU nonroad Stage V emissions.

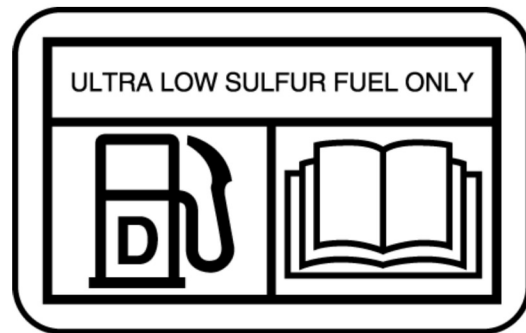

Illustration 70

g02157153

Illustration 70 is a representation of the label that will be installed next to the fuel filler cap on the fuel tank of the application.

The fuel specifications that are listed in the table 25 are released as acceptable to use on all 904J series of engine.

Table 25

Acceptable Fuel Specification for the 904J Series of Engines ⁽¹⁾	
Fuel Specification	Comments
EN590	European Automotive Diesel Fuel (DERV)
"ASTM D975 GRADE 1D S15"	"North American Light Distillate Diesel fuel with less than 15 PPM sulfur level"
"ASTM D975 GRADE 2D S15"	"North American Middle Distillate general-purpose Diesel fuel with less than 15 PPM sulfur level"
"JIS K2204"	"Japanese Diesel Fuel" Must meet the requirements that are stated in the lubricity section of this "Operation and Maintenance Manual" Fluid Recommendations.

(continued)

(Table 25, contd)

"BS 2869: 2017 CLASS A2 or EU equivalent"	UK Off-Road Diesel fuel
"CEN TS15940"	"Paraffinic diesel fuel from synthesis or hydrotreatment", "Biomass-to-liquid" (BTL), "Gas-to-liquid" (GTL), Hydrotreated Vegetable Oil (HVO). Refer to the Renewable and Alternative Fuels section of this "Operation and Maintenance Manual" Fluid Recommendations for more information.
Biodiesel blends up to B20 meeting: ASTM D7467 - North America EN16709 B20 specification - Europe	Refer to the Recommendation for Biodiesel and Using B20 section of this "Operation and Maintenance Manual" Fluid Recommendations for more information.

(1) All the fuels must comply with the specification in the table for the Perkins Specification Distillate Diesel Fuel.

Diesel Fuel Characteristics

Cetane Number

Cetane number is a measure of the ignition quality of diesel fuel. Fuel that has a higher cetane number will give a shorter ignition delay and will produce a better ignition quality. Cetane numbers are derived for fuels against proportions of cetane and heptamethylnonane in the standard CFR engine. Refer to "ISO 5165" for the test method.

In Europe for non-road Stage V emissions regulations require minimum cetane number of 45. In the North America, minimum cetane number requirement is 40.

Cetane number affect engine cold start ability, exhaust emissions, combustion noise, and altitude performance. Fuel with a higher cetane number is desirable and recommended. This is particularly important for operations in cold weather and at high altitude.

Viscosity

Viscosity is the property of a liquid of offering resistance to shear or flow. Viscosity decreases with increasing temperature. This decrease in viscosity follows a logarithmic relationship for normal fossil fuel. The common reference is to kinematic viscosity. Kinematic viscosity is the quotient of the dynamic viscosity that is divided by the density. The determination of kinematic viscosity is normally by readings from gravity flow viscometers at standard temperatures. Refer to "ISO 3104" for the test method.

The viscosity of the fuel is significant because fuel serves as a lubricant for the fuel system components. Fuel must have sufficient viscosity to lubricate the fuel system in both extremely cold temperatures and extremely hot temperatures. If the kinematic viscosity of the fuel is lower than "1.4 cSt" at the fuel injection pump, damage to the fuel injection pump can occur. This damage can be excessive scuffing and seizure. Low viscosity may lead to difficult hot restarting, stalling, and loss of performance. High viscosity may result in seizure of the pump.

Perkins recommends kinematic viscosities of 1.4 and 4.5 mm²/sec that is delivered to the fuel injection pump. If a fuel with a low viscosity is used, cooling of the fuel may be required to maintain 1.4 cSt or greater viscosity at the fuel injection pump. Fuels with a high viscosity might require fuel heaters to lower the viscosity to 4.5 cSt at the fuel injection pump.

Density

Density is the mass of the fuel per unit volume at a specific temperature. This parameter has a direct influence on engine performance and a direct influence on emissions. This influence determines from a heat output given injected volume of fuel. This parameter is quoted in the following kg/m³ at 15 °C (59 °F).

Perkins recommends a density of 841 kg/m³ to obtain the correct power output. Lighter fuels are acceptable but these fuels will not produce the rated power.

Sulfur

The level of sulfur is governed by emissions legislations. Regional regulation, national regulations, or international regulations can require a fuel with a specific sulfur limit. The sulfur content of the fuel and the fuel quality must comply with all existing local regulations for emissions.

Perkins 904J series diesel engines have been designed to operate only with Ultra Low Sulfur Diesel (ULSD) fuel. By using the test methods "ASTM D5453, or ISO 20846", the content of sulfur in ULSD fuel must be below 15 PPM (mg/kg) or 0.0015% mass.

In the USA, EPA regulations require the use of ULSD fuel with less than 0.0015 percent (15 PPM) (mg/kg)) sulfur content.

In Europe, sulfur free diesel fuels with sulphur content less than 0.0010 percent (10 PPM) (mg/kg)) is required by regulation for use in engines certified to EU nonroad Stage V emissions.

NOTICE

Use of diesel fuel with higher than 15 PPM sulphur limit in these engines will harm or permanently damage emissions control systems and/or shorten service interval.

Lubricity

Lubricity is the capability of the fuel to prevent pump wear. The fluids lubricity describes the ability of the fluid to reduce the friction between surfaces that are under load. This ability reduces the damage that is caused by friction. Fuel injection systems rely on the lubricating properties of the fuel. Until fuel sulfur limits were mandated, the fuels lubricity was generally believed to be a function of fuel viscosity.

The lubricity has particular significance to the current ultra low sulfur fuel, and low aromatic fossil fuels. These fuels are made to meet stringent exhaust emissions.

The lubricity of these fuels must not exceed wear scar diameter of 0.52 mm (0.0205 inch). The fuel lubricity test must be performed on an HFRR, operated at 60 °C (140 °F). Refer to "ISO 12156-1".

NOTICE

The fuels system has been qualified with fuel having lubricity up to 0.52 mm (0.0205 inch) wear scar diameter as tested by "ISO 12156-1". Fuel with higher wear scar diameter than 0.52 mm (0.0205 inch) will lead to reduced service life and premature failure of the fuel system.

Fuel additives can enhance the lubricity of a fuel. Contact your fuel supplier for those circumstances when fuel additives are required. Your fuel supplier can make recommendations for additives to use, and for the proper level of treatment.

Distillation

Distillation is an indication of the mixture of different hydrocarbons in the fuel. A high ratio of lightweight hydrocarbons can affect the characteristics of combustion.

Recommendation for Biodiesel and Using B20

Biodiesel is a fuel that can be defined as mono-alkyl esters of fatty acids. Biodiesel is a fuel that can be made from various feedstocks. The most commonly available biodiesel in Europe is Rape Methyl Ester (RME). This biodiesel is derived from rapeseed oil. Soy Methyl Ester (SME) is the most common biodiesel in the United States. This biodiesel is derived from soybean oil. Soybean oil or rapeseed oil are the primary feedstocks. These fuels are together known as Fatty Acid Methyl Esters (FAME).

Raw pressed vegetable oils are NOT acceptable for use as a fuel in any concentration in compression engines. Without esterification, these oils solidify in the crankcase and the fuel tank. These fuels may not be compatible with many of the elastomers that are used in engines that are manufactured today. In original forms, these oils are not suitable for use as a fuel in compression engines. Alternate base stocks for biodiesel may include animal tallow, waste cooking oils, or various other feedstocks. To use any of the products that are listed as fuel, the oil must be esterified.

Fuel made of 100 percent FAME is generally referred to as B100 biodiesel or neat biodiesel.

Biodiesel can be blended with distillate diesel fuel. The blends can be used as fuel. The most commonly available biodiesel blends are B5, which is 5 percent biodiesel and 95 percent distillate diesel fuel. B20, which is 20 percent biodiesel and 80 percent distillate diesel fuel.

Note: The percentages given are volume-based.

The U.S. distillate diesel fuel specification "ASTM D975" includes up to B5 (5 percent) biodiesel.

European distillate diesel fuel specification EN590 includes up to B7 (7 percent) biodiesel.

Note: Engines that are manufactured by Perkins are certified by use of the prescribed Environmental Protection Agency (EPA) and European Certification fuels. Perkins does not certify engines on any other fuel. The user of the engine has the responsibility of using the correct fuel that is recommended by the manufacturer and allowed by the EPA and other appropriate regulatory agencies.

Specification Requirements

The neat biodiesel must conform to the latest "EN14214 or ASTM D6751" (in the USA). The biodiesel can only be blended in mixture of up to 20% by volume in acceptable mineral diesel fuel meeting latest edition of "EN590 or ASTM D975 S15" designation.

In Europe diesel blends up to B20 must meet the requirements listed in the latest edition of "EN16709" B20 specification.

In United States Biodiesel blends of B6 to B20 must meet the requirements listed in the latest edition of "ASTM D7467" (B6 to B20) and must be of an API gravity of 30-45.

In North America biodiesel and biodiesel blends must be purchased from the BQ-9000 accredited producers and BQ-9000 certified distributors.

In other areas of the world, the use of biodiesel that is BQ-9000 accredited and certified, or that is accredited and certified by a comparable biodiesel quality body to meet similar biodiesel quality standards is required.

Engine Service Requirements

Aggressive properties of biodiesel fuel may cause debris in the fuel tank and fuel lines. The aggressive properties of biodiesel will clean the fuel tank and fuel lines. This cleaning of the fuel system can prematurely block the fuel filters. Perkins recommend that after the initial usage of B20 biodiesel blended fuel the fuel filters must be replaced at 50 hours.

Glycerides present in biodiesel fuel will also cause fuel filters to become blocked more quickly. Therefore the regular service interval should be reduced to 250 hours.

When biodiesel fuel is used, crank case oil and aftertreatment systems may be influenced. This influence is due to the chemical composition and characteristics of biodiesel fuel, such as density and volatility, and to chemical contaminants that can be present in this fuel, such as alkali and alkaline metals (sodium, potassium, calcium, and magnesium).

- Crankcase oil fuel dilution can be higher when biodiesel or biodiesel blends are used. This increased level of fuel dilution when using biodiesel or biodiesel blends is related to the typically lower volatility of biodiesel. In-cylinder emissions control strategies utilized in many of the industrial latest engine designs may lead to a higher level of biodiesel concentration in the sump. The long-term effect of biodiesel concentration in crankcase oil is unknown currently.
- Perkins recommend the use of oil analysis to check the quality of the engine oil if biodiesel fuel is used. Ensure that the level of biodiesel in the fuel is noted when the oil sample is taken.

Performance Related Issues

Due to the lower energy content than the standard distillate fuel B20 will cause a power loss in order of 2 to 4 percent. In addition, over time the power may deteriorate further due to deposits in the fuel injectors.

Biodiesel and biodiesel blends are known to cause an increase in fuel system deposits, most significant of which are deposits within the fuel injector. These deposits can cause a loss in power due to restricted or modified fuel injection or cause other functional issues associated with these deposits.

Note: Perkins Fuel Cleaner (part number T400012) is most effective in cleaning and preventing the formation of deposits. Perkins Diesel Fuel Conditioner helps to limit deposit issues by improving the stability of biodiesel and biodiesel blends. For more information refer to Perkins Diesel Fuel Cleaner.

Biodiesel fuel contains metal contaminants (sodium, potassium, calcium, and/or magnesium) that form ash products upon combustion in the diesel engine. The ash can have an impact on the life and performance of aftertreatment emissions control devices and can accumulate in DPF. The ash accumulation may cause the need for more frequent ash service intervals and cause loss of performance

General Requirements

Biodiesel has poor oxidation stability, which can result in long-term problems in the storage of biodiesel. Biodiesel fuel should be used within 6 months of manufacture. Equipment should not be stored with the B20 biodiesel blends in the fuel system for longer than 3 months.

Due to poor oxidation stability and other potential issues, it is strongly recommended that engines with limited operational time either not use B20 biodiesel blends or, whilst accepting some risk, limit biodiesel blend to a maximum of B5. Examples of applications that should limit the use of biodiesel are the following: Standby Generator sets and certain emergency vehicles.

For standby generator sets and emergency vehicles that cannot avoid use of biodiesel blends fuel quality in the engine fuel tank must be sampled and checked monthly. Test should include acid number (EN14104), oxidation stability (EN 15751 commonly know as the Rancimant test), and sediment (ISO12937). For standby generator sets oxidation stability of biodiesel blend must be 20 hours or more as per EN 15751. If the test shows that the fuel has degraded, fuel tank must be drained and engine flushed by running with the fresh high-quality diesel fuel.

Perkins strongly recommended that seasonally operated engines have the fuel systems, including fuel tanks, flushed with conventional diesel fuel before prolonged shutdown periods. An example of an application that should seasonally flush the fuel system is a combine harvester.

Microbial contamination and growth can cause corrosion in the fuel system and premature plugging of the fuel filter. Consult your supplier of fuel for assistance in selecting appropriate anti-microbial additive.

Water accelerates microbial contamination and growth. When biodiesel is compared to distillate fuels, water is naturally more likely to exist in the biodiesel. Therefore check frequently and if necessary, drain the water separator.

Materials such as brass, bronze, copper, lead, tin, and zinc accelerate the oxidation process of the biodiesel fuel. The oxidation process can cause deposits formation therefore these materials must not be used for fuel tanks and fuel lines.

Renewable and Alternative Fuels

Perkins supports development and use of renewable fuels through sustainability initiatives. In recent years various forms of renewable and alternative (synthetic) diesel fuels have started to emerge.

Synthetic diesel fuels are produced by gasification of various feedstock and then synthesis to liquid to obtain paraffinic diesel fuel. Based on the feedstock used these fuels are commonly referred to as Biomass to liquid (BTL), Gas to liquid (GTL) and Coal to liquid (CTL). Hydrotreating of vegetable oils and animal fats is another emerging process for production of bio based diesel fuel called Hydrotreated Vegetable Oil (HVO).

BTL and HVO fuels are considered to be low carbon fuels as they reduce carbon foot print compared to fossil fuels and are commonly referred to as renewable fuels. These fuels must not be confused with biodiesel FAME which is fundamentally different fuel and is discussed in a separate section in this manual.

These paraffinic diesel fuels have virtually no sulphur or aromatics and have very high cetane numbers which enable very clean burning and efficient engine operation. Chemically these fuels are similar to diesel fuel derived from petroleum.

Paraffinic diesel fuels are considered as acceptable to use as a directed replacement to petroleum diesel or as a blendstock for petroleum diesel fuel in Perkins diesel engines provided they meet latest edition of the paraffinic diesel fuel specification "CENTS 15940". The fuel should also meet requirements described in table 24 , Perkins Specification for Distillate Diesel Fuel, EN590, or latest ASTM D975 specification with the exception of density, which is inherently lower for paraffinic fuels. **Due to lower density, some rated power loss might be noticeable.**

Ensure that the fuel has got appropriate cold flow properties (cloud point and CFPP) for the minimum statistical ambient temperature the engine is expected to see in the operation. The fuel must also meet lubricity requirements as specified in the lubricity section of this "Operation and Maintenance Manual" Fluid Recommendations

Fuel for Cold-Weather Operation

The European standard "EN590" contains climate dependant requirements and a range of options. The options can be applied differently in each country. There are five classes that are given to arctic climates and severe winter climates. 0, 1, 2, 3 and 4.

Fuel that complies with "EN590" CLASS 4 can be used at temperatures as low as -44°C (-47.2°F). Refer to "EN590" for a detailed discretion of the physical properties of the fuel.

The diesel fuel "ASTM D975 1-D" used in the United States of America may be used in very cold temperatures that are below -18°C (-0.4°F).

Aftermarket Fuel Additives

NOTICE

Perkins does not warrant the quality or performance of non-Perkins fluids and filters.

When auxiliary devices, accessories, or consumables (filters, additives) which are made by other manufacturers are used on Perkins products, the Perkins warranty is not affected simply because of such use.

However, failures that result from the installation or use of other manufacturers devices, accessories, or consumables are NOT Perkins defects. Therefore, the defects are NOT covered under the Perkins warranty.

Supplemental diesel fuel additives are not generally recommended. This recommendation is due to potential damage to the fuel system or the engine. Your fuel supplier or the fuel manufacturer will add the appropriate supplemental diesel fuel additives.

Perkins recognizes the fact that additives may be required in some special circumstances.

Note: Some anti-corrosion additives can lead to injector fouling, this fouling can cause the injector to operate incorrectly.

Contact your fuel supplier for those circumstances when fuel additives are required. Your fuel supplier can recommend the appropriate fuel additive and the correct level of treatment.

Note: For the best results, your fuel supplier should treat the fuel when additives are required. The treated fuel must meet the requirements that are stated in table 24 .

Perkins Diesel Fuel System Cleaner

Perkins Fuel Cleaner (part number T400012) is the only fuel cleaner that is recommended by Perkins.

If biodiesel or biodiesel blends of fuel are to be used, Perkins require the use of Perkins fuel cleaner. The use of the fuel is to remove deposits within the fuel system that is created with the use of biodiesel. For more information on the use of biodiesel and biodiesel blends refer to Recommendation for Biodiesel and Using B20.

Perkins fuel cleaner will remove deposits that can form in the fuel system with the use of biodiesel and biodiesel blends. These deposits can create a loss of power and engine performance.

Once the fuel cleaner has been added to the fuel, the deposits within the fuel system are removed after 30 hours of engine operation. For maximum results, continue to use the fuel cleaner for up to 80 hours. Perkins fuel cleaner can be used on an on-going basis with no adverse impact on engine or fuel system durability.

Details instruction on the rate of which the fuel cleaner is to be used are on the container.

Note: Perkins fuel cleaner is compatible with existing and U.S. EPA Tier 4 nonroad certified diesel engine emission control catalysts and particulate filters. Perkins fuel system cleaner contains less than 15 ppm of sulfur and is acceptable for use with ULSD fuel.

Contamination Control Recommendations for Fuels

Fuels of “ISO 18/16/13” cleanliness level or cleaner as dispensed into the engine or application fuel tank should be used. This will reduce risk of power loss, fuel system failures, and related down time of engines. This cleanliness level is important for new fuel system designs such as common rail injection systems and unit injectors. These fuels systems utilize higher fuel injection pressures and have tight clearances between moving parts to meet required stringent emissions regulations. Peak injection pressures in current fuel injection systems may exceed 2000 bar (29000 psi). Clearances in these systems are less than 5 µm. As a result, particle contaminants as small as 4 µm can cause scoring and scratching of internal pump and injector surfaces and of injector nozzles.

Water in the fuel causes cavitation, corrosion of fuel system parts, and provides an environment where microbial growth in the fuel can flourish. Other sources of fuel contamination are soaps, gels, or other compounds that may result from undesirable chemical interactions in the fuels, particularly in ULSD. Gels and other compounds can also form in biodiesel fuel at low temperatures or if biodiesel is stored for extended periods. The best indication of microbial contamination, fuel additives, or cold temperature gel is rapid filter plugging of bulk fuel filters or application fuel filters.

To reduce downtime due to contamination, follow these fuel maintenance guidelines.

- Use high-quality fuels per recommended and required specifications
- Fill fuel tanks with fuels of “ISO 18/16/13” cleanliness level or cleaner, in particular for engines with common rail and unit injection systems. When you refuel the tank, filter the fuel through a 4 µm absolute filter (Beta 4 = 75 up to 200) to reach the recommended cleanliness level. This filtration should be installed at the device that dispenses the fuel to the fuel tank. In addition, filtration at the dispensing point should remove water to ensure that fuel is dispensed at 500 ppm water or less.
- Perkins recommends the use of bulk fuel filter / coalescer units which clean the fuel of both particulate contamination and water in a single pass.
- Ensure that you use Perkins Advanced Efficiency Fuel Filters. Change your fuel filters per recommended service requirements or as needed.
- Drain your water separators daily.
- Drain your fuel tanks of sediment and water per the Operation and Maintenance Manual instructions.
- Install and maintain a properly designed bulk filter / coalescer filtration system. Continuous bulk filtration systems may be required to ensure that dispensed fuel meets the cleanliness target. Consult your Perkins distributor for availability of bulk filtration products.
- Centrifugal filters may need to be used as a pre-filter with fuel that is severely contaminated with gross amounts of water and/or large particulate contaminants. Centrifugal filters can effectively remove large contaminants. Centrifugal filters may not be able to remove the small abrasive particles required to achieve the recommended “ISO” cleanliness level. Bulk filter / coalescers are necessary as a final filter to achieve the recommended cleanliness level.
- Install desiccant type breathers of 4 µm or less absolute efficiency with the ability to remove water on bulk storage tanks.
- Follow proper practices of fuel transportation. Filtration from the storage tank to the application promotes the delivery of clean fuel. Fuel filtration can be installed at each transport stage to keep the fuel clean.
- Cover, protect, and ensure cleanliness of all connection hoses, fittings, and dispensing nozzles.

Consult your local Perkins distributor for additional information on Perkins designed and produced filtration products.

i07911111

Fluid Recommendations

General Coolant Information

NOTICE

Never add coolant to an overheated engine. Engine damage could result. Allow the engine to cool first.

NOTICE

If the engine is to be stored in, or shipped to an area with below freezing temperatures, the cooling system must be either protected to the lowest outside temperature or drained completely to prevent damage.

NOTICE

Frequently check the specific gravity of the coolant for proper freeze protection or for anti-boil protection.

Clean the cooling system for the following reasons:

- Contamination of the cooling system
 - Overheating of the engine
 - Foaming of the coolant
-

NOTICE

Never operate an engine without water temperature regulators in the cooling system. Water temperature regulators help to maintain the engine coolant at the proper operating temperature. Cooling system problems can develop without water temperature regulators.

Many engine failures are related to the cooling system. The following problems are related to cooling system failures: Overheating, leakage of the water pump and plugged radiators or heat exchangers.

These failures can be avoided with correct cooling system maintenance. Cooling system maintenance is as important as maintenance of the fuel system and the lubrication system. Quality of the coolant is as important as the quality of the fuel and the lubricating oil.

Coolant is normally composed of three elements: Water, additives, and glycol.

Water

NOTICE

Never use water alone as coolant. Water alone is corrosive and does not provide any protection against boiling or freezing.

Water is used in the cooling system to transfer heat.

Distilled water or deionized water is recommended for use in engine cooling systems.

DO NOT use the following types of water in cooling systems: Hard water, softened water that has been conditioned with salt and sea water.

If distilled water or deionized water is not available, use water with the properties that are listed in Table 26 .

Table 26

Acceptable Water	
Property	Maximum Limit
Chloride (Cl)	40 mg/L
Sulfate (SO ₄)	100 mg/L
Total Hardness	170 mg/L
Total Solids	340 mg/L
Acidity	pH of 5.5 to 9.0

For a water analysis, consult one of the following sources:

- Local water utility company
- Agricultural agent
- Independent laboratory

Additives

Additives help to protect the metal surfaces of the cooling system. A lack of coolant additives or insufficient amounts of additives enable the following conditions to occur:

- Corrosion
- Formation of mineral deposits
- Rust
- Scale
- Foaming of the coolant

Many additives are depleted during engine operation. These additives must be replaced periodically.

Additives must be added at the correct concentration. Over concentration of additives can cause the inhibitors to drop out-of-solution. The deposits can enable the following problems to occur:

- Formation of gel compounds
- Reduction of heat transfer
- Leakage of the water pump seal
- Plugging of radiators, coolers, and small passages

Glycol

Glycol in the coolant helps to provide protection against the following conditions:

- Boiling
- Freezing
- Cavitation of the water pump

For optimum performance, Perkins recommends a 50 percent by volume of glycol in the finished coolant (also referred to as 1:1 mixture).

Note: Use a mixture that will provide protection against the lowest ambient temperature.

Note: 100 percent pure glycol will freeze at a temperature of $-13\text{ }^{\circ}\text{C}$ ($8.6\text{ }^{\circ}\text{F}$).

Most conventional antifreezes use ethylene glycol. Propylene glycol may also be used. In a 1:1 mixture with distilled or deionized water, ethylene and propylene glycol provide similar protection against freezing and boiling. Refer to Table 27 and refer to table 28 .

Table 27

Ethylene Glycol	
Concentration	Freeze Protection
50 Percent	$-36\text{ }^{\circ}\text{C}$ ($-33\text{ }^{\circ}\text{F}$)
60 Percent	$-51\text{ }^{\circ}\text{C}$ ($-60\text{ }^{\circ}\text{F}$)

NOTICE

Do not use propylene glycol in concentrations that exceed 50 percent glycol because of the reduced heat transfer capability of propylene glycol. Use ethylene glycol in conditions that require additional protection against boiling or freezing.

Table 28

Propylene Glycol	
Concentration	Freeze Protection
50 Percent	$-29\text{ }^{\circ}\text{C}$ ($-20\text{ }^{\circ}\text{F}$)

Some commercially available coolants are based on alternative fluids, such as 1, 3-propanediol (beta-propylene glycol, PDO), glycerin (glycerol), or mixtures of these alternatives with ethylene/propylene glycols. At the time of publication of this document no industry standard exists for coolants based on these chemicals. Until such standard/specifications are published and evaluated, use of PDO, glycerine, or other alternative coolants are not recommended in Perkins engines.

To check the concentration of glycol in the coolant, measure the specific gravity of the coolant.

Coolant Terminology

- ELC_____Extended Life Coolant. A coolant that relies on organic inhibitors for corrosion and cavitation protection. Also known as Organic Acid Technology (OAT) coolant.
- ELI_____Extended Life Inhibitor
- SCA_____Supplement Coolant Additive, concentrated inorganic inhibitor package
- ASTM_____American Society for Testing and Materials
- Conventional Coolant_____a coolant that relies on inorganic inhibitors for corrosion and cavitation protection
- Hybrid Coolant_____a coolant in which the corrosion and cavitation protection is based on a mixture of organic and inorganic inhibitors.
- Extender_____concentrated organic inhibitor package

Coolant Recommendations

The following three glycol-based coolants are recommended for use in Perkins diesel engines:

Preferred – Perkins ELC

Acceptable – A commercial heavy-duty antifreeze that meets “ASTM D6210” specifications. Must be replaced after 2 years.

Adequate – A commercial heavy-duty antifreeze that meets “ASTM D4985” specifications. Must be replaced after 1 year.

NOTICE

The Perkins industrial engines must be operated with a 1:1 (50 Percent) mixture of distilled or de-ionized water and glycol. This concentration allows the NOx reduction system to operate correctly at high ambient temperatures.

Maintenance Section
Fluid Recommendations

NOTICE

Do not use a commercial coolant/antifreeze that only meets the ASTM D3306 specification. This type of coolant/antifreeze is made for light automotive applications.

NOTICE

A commercial heavy-duty antifreeze that meets "ASTM D4985" specification requires a treatment with an SCA at the initial fill. Read the label or the instructions that are provided by the manufacturer of the product.

NOTICE

A commercial heavy-duty antifreeze that meets either "ASTM D4985" or "ASTM D6210" specification requires the SCA concentration to be checked at 500-hour service intervals.

Perkins recommends a 50 percent volume glycol and distilled or deionized water of the correct specification. This mixture will provide optimum performance as a coolant/antifreeze.

Distilled or deionized water is preferred. Water which has the recommended properties may be used.

Table 29

Coolant Service Life		
Coolant Type	Service Life ⁽¹⁾	Required Maintenance
Commercial Heavy-Duty Antifreeze that meets "ASTM D6210"	3000 Service Hours or Two Years	SCA at maintenance intervals
Commercial Heavy-Duty Antifreeze that meets "ASTM D4985"	3000 Service Hours or One Year	SCA at initial fill and SCA at maintenance intervals
Perkins ELC	6,000 Service Hours or Three Years	-

⁽¹⁾ Use the interval that occurs first. The cooling system must also be flushed out at this time. These service lives can only be met if regular coolant sampling, analysis, and proper maintenance are carried out, with the engine in normal service.

ELC

Perkins provides ELC for use in the following applications:

- Heavy-duty spark ignited gas engines
- Heavy-duty diesel engines
- Automotive applications

The anti-corrosion package for ELC is different from the anti-corrosion package for other coolants. ELC is an ethylene glycol base coolant. However, ELC contains organic corrosion inhibitors and antifoam agents with low amounts of nitrite. Perkins ELC has been formulated with the correct amount of these additives to provide superior corrosion protection for all metals in engine cooling systems.

ELC is available in a premixed cooling solution with distilled water. ELC is a 50 percent by volume of glycol mixture. The Premixed ELC provides freeze protection to -36 °C (-33 °F). The Premixed ELC is recommended for the initial fill of the cooling system. The Premixed ELC is also recommended for topping off the cooling system.

Containers of several sizes are available. Consult your Perkins distributor for the part numbers.

ELC Cooling System Maintenance**Correct additions to the Extended Life Coolant****NOTICE**

Mixing Extended Life Coolant with other products reduces the Extended Life Coolant service life. Failure to follow the recommendations can reduce cooling system components life unless appropriate corrective action is performed.

To maintain the correct balance between the antifreeze and the additives, you must maintain the recommended concentration of ELC. Lowering the proportion of antifreeze lowers the proportion of additive. Lowering the ability of the coolant to protect the system will form pitting, from cavitation, from erosion, and from deposits.

NOTICE

Do not use a conventional coolant to top-off a cooling system that is filled with Extended Life Coolant (ELC).

Do not use Supplemental Coolant Additive (SCA).

Do not use ELC in systems with SCA filters. When switching from conventional coolant to ELC in a system equipped with SCA filter, remove the filter from the system to prevent ELC contamination and filter corrosion and leaks.

ELC Cooling System Cleaning

Note: If the cooling system is already using ELC, cleaning agents are not required to be used at the specified coolant change interval. Cleaning agents are only required if the system has been contaminated by the addition of some other type of coolant or by cooling system damage.

Distilled or deionized water is the only cleaning agent that is required when ELC is drained from the cooling system.

Before the cooling system is filled, the heater control (if equipped) must be set to the HOT position. Refer to the OEM to set the heater control. After the cooling system is drained and the cooling system is refilled, operate the engine until the coolant level reaches the normal operating temperature and until the coolant level stabilizes. As needed, add the coolant mixture to fill the system to the specified level.

Changing to Perkins ELC

To change from heavy-duty antifreeze to the Perkins ELC, perform the following steps:

NOTICE

Care must be taken to ensure that all fluids are contained during performance of inspection, maintenance, testing, adjusting and the repair of the product. Be prepared to collect the fluid with suitable containers before opening any compartment or disassembling any component containing fluids.

Dispose of all fluids according to local regulations and mandates.

1. Drain the coolant into a suitable container.
2. Dispose of the coolant according to local regulations.
3. Flush the system with distilled or deionized water to remove any debris.
4. Use an appropriate cleaner to clean the system. Follow the instruction on the label.
5. Drain the cleaner into a suitable container. Flush the cooling system with distilled or deionized water.
6. Fill the cooling system with distilled or deionized water and operate the engine until the engine is warmed to 49° to 66°C (120° to 150°F).

NOTICE

Incorrect or incomplete flushing of the cooling system can result in damage to copper and other metal components.

To avoid damage to the cooling system, make sure that the cooling system is completely flushed with distilled or deionized water. Continue to flush the system until all signs of the cleaning agent are gone.

Most commercial cooling system cleaning agents are corrosive and their use is not recommended by Perkins. If these agents have to be used to remove heavy deposits, then they should not be left in the system any longer than recommended by the agent manufacturer and engine temperature should not exceed 30 °C. The system must be thoroughly flushed with distilled or deionized water after use of these cleaning agents.

7. Drain the cooling system into a suitable container and flush the cooling system with distilled or deionized water.

Note: The cooling system cleaner must be thoroughly flushed from the cooling system. Cooling system cleaner that is left in the system will contaminate the coolant. The cleaner may also corrode the cooling system.

8. Repeat Steps 6 and repeat steps 7 until the system is completely clean.
9. Fill the cooling system with the Perkins Premixed ELC.

ELC Cooling System Contamination

NOTICE

Mixing ELC with other products reduces the effectiveness of the ELC and shortens the ELC service life. Failure to follow these recommendations can result in shortened cooling system component life.

Do not mix types and specifications of coolant.

Do not mix types and specifications of SCAs.

ELC cooling systems can withstand contamination to a maximum of 10 percent of conventional heavy-duty antifreeze or SCA. If the contamination exceeds 10 percent of the total system capacity, perform ONE of the following procedures:

- Drain the cooling system into a suitable container. Dispose of the coolant according to local regulations. Flush the system with a 5 to 10 percent solution of Perkins ELC. Fill the system with the Perkins ELC.

- Maintain the system as a conventional Heavy-Duty Coolant. Treat the system with an SCA. Change the coolant at the interval that is recommended for the conventional Heavy-Duty Coolant.

Commercial Heavy-Duty Antifreeze and SCA

NOTICE

Commercial Heavy-Duty Coolant which contains Amines as part of the corrosion protection system must not be used.

NOTICE

Never operate an engine without water temperature regulators in the cooling system. Water temperature regulators help to maintain the engine coolant at the correct operating temperature. Cooling system problems can develop without water temperature regulators.

Check the antifreeze (glycol concentration) to ensure adequate protection against boiling or freezing. Perkins recommends the use of a refractometer for checking the glycol concentration. Do not use a hydrometer.

NOTICE

Do not mix types and specifications of coolant.

Do not mix types and specifications of SCAs.

Do not mix SCAs and Extenders.

Only use SCAs or Extender approved by coolant manufacturer and are compatible with coolant.

Perkins engine cooling systems should be tested at 250 hour intervals for the concentration of SCA.

Additions of SCA are based on the results of the test. SCA that is liquid may be needed at 250 hour intervals.

Adding the SCA to Heavy-Duty Coolant at the Initial Fill

Use the equation that is in Table 30 to determine the amount of SCA that is required when the cooling system is initially filled.

Coolants that conform to "ASTM D4985" and do not conform to "ASTM D6210" will require addition of SCA at initial fill.

Table 30

Equation For Adding The SCA To The Heavy-Duty Coolant At The Initial Fill
$V \times 0.07 = X$
V is the total volume of the cooling system.
X is the amount of SCA that is required.

Table 31 is an example for using the equation that is in Table 30 .

Table 31

Example Of The Equation For Adding The SCA To The Heavy-Duty Coolant At The Initial Fill		
Total Volume of the Cooling System (V)	Multiplication Factor	Amount of SCA that is Required (X)
15 L (4 US gal)	× 0.07	1.05 L (35.5 oz)

Adding SCA to the Commercial Heavy-Duty Coolant for Maintenance

Heavy-duty antifreezes of all types require periodic additions of SCA.

Test the antifreeze periodically for the concentration of SCA.

Additions of SCA are based on the results of the test. The size of the cooling system determines the amount of SCA that is needed.

Use the equation that is in Table 32 to determine the amount of SCA that is required, if necessary:

Table 32

Equation for Adding the SCA to the Commercial Heavy-Duty Coolant for Maintenance
$V \times 0.023 = X$
V is the total volume of the cooling system.
X is the amount of SCA that is required.

Table 33 is an example for using the equation that is in Table 32 .

Table 33

Example of the Equation for Adding the SCA to the Commercial Heavy-Duty Coolant for Maintenance		
Total Volume of the Cooling System (V)	Multiplication Factor	Amount of SCA that is Required (X)
15 L (4 US gal)	× 0.023	0.35 L (11.7 oz)

Cleaning the System of Heavy-Duty Antifreeze

Clean the cooling system for the following conditions.

- Clean the cooling system after used coolant is drained or before the cooling system is filled with new coolant
- Clean the cooling system whenever the coolant is contaminated or whenever the coolant is foaming
- The cooling system must be free from rust, scale, and any deposits, before corrosion inhibitors can be effective

To clean the cooling system of heavy-duty antifreeze, perform the following steps:

1. Drain the cooling system.
2. Fill the system with suitable distilled or deionized water.

NOTICE

Most commercial cooling system cleaning agents are corrosive and their use is not recommended by Perkins. If these cleaning agents have to be used to clean heavy deposits, then they should not be left in the system any longer than recommended by manufacturers. Also the engine temperature should not exceed 30° C (86° F).

The system must be thoroughly flushed with distilled or deionized water after use of cleaning agents.

NOTICE

Cleaning agents for industrial cooling system must not be used. These cleaning agents are very aggressive and cause damage to cooling system components.

3. Dissolve a suitable cleaning agent in water: use non-foaming detergent to clean oil contamination or a cooling system cleaner to clean deposits. Consult your Perkins dealer for suitable product.
4. Run the engine for approximately 30 minutes, leave the engine to cool down, and drain the system.
5. Take a sample of the solution from the system. Allow the sample to sit for at least 30 minutes and check for signs of oil or deposits. If contaminant is still present repeat step 1 to step 4.
6. Flush the system with distilled or deionized water.

7. Fill the system with new coolant.

i10205573

Fluid Recommendations (Diesel Exhaust Fluid (DEF))

General Information

Diesel Exhaust Fluid (DEF) is a liquid that is injected into the aftertreatment system before Selective Catalytic Reduction (SCR). This system of injecting the DEF into the exhaust will cause a chemical reaction in the SCR system. The Nitrogen Oxide (NOx) molecules in the exhaust are converted to elemental nitrogen and water. This conversion will reduce the emission of the engine.

Refer to Perkins Diesel Engines Fluids Recommendations, M0113102 for additional information that relates to DEF.

Specification

DEF that is used in Perkins engines must meet the ISO specification 22241-1 for quality. The ISO specification 22241-1 requirements are met by many brands of DEF, including the ones that carry the AdBlue or API certification."

The document series ISO standard 22241 will give information on quality requirements, test methods, handling, transportation, storage, and refilling interface.

Spillage

Care should be taken when dispensing DEF. Spills should be cleaned immediately. All surfaces should be wiped clean and rinsed with water.

DEF that has been spilt will crystallize when the water within the liquid evaporates. Spilt DEF will attack paint and metal. If DEF is spilt, wash the area with water.

Caution should be used when dispensing DEF near an engine that has recently been running. Spilling DEF onto hot components may cause the release of ammonia vapors. Do not breathe ammonia vapors. Do not clean up any spills with bleach.

Filling the DEF Tank

The fill cap on the DEF tank is colored blue. A special nozzle size is required to fill a DEF tank. The DEF level is important, allowing the DEF tank to run dry or operate at a low level can affect the engine operation. Ensure that the DEF tank is on level ground before the tank is filled. Because of the corrosive nature of DEF, the correct materials must be used when filling a DEF tank. For more information on filling instructions, refer to Operation and Maintenance Manual, "Diesel Exhaust Fluid (Emission Related Component) – Fill".

DEF Quality

The quality of DEF can be measured by using a refractometer. The DEF must comply with ISO standard 22241-1 with the urea solution of 32.5 percent. Perkins offer a T400195 Refractometer for checking the concentration of the DEF.

Cleanliness

Contaminants can degrade the quality and life of DEF. Filtering DEF is recommended when dispensed into the DEF tank. Filters should be compatible with DEF and should be used exclusively with DEF. Check with the filter supplier to confirm compatibility with DEF before using. Mesh-type filters using compatible metals, such as stainless steel, are recommended. Paper (cellulose) media and some synthetic filter media are not recommended because of degradation during use.

Care should be taken when dispensing DEF. Spills should be cleaned immediately. Machine or engine surfaces should be wiped clean and rinsed with water. Caution should be used when dispensing DEF near an engine that has recently been running. Spilling DEF onto hot components will cause harmful vapors.

Storage

Do not store DEF in direct sunlight.

Table 34

Storage Temperature	Expected DEF Life
Below 25° C (77° F)	18 months
25° C (77° F) to 30° C (86° F)	12 months
30° C (86° F) to 35° C (95° F)	6 months
Above 35° C (95° F)	test quality before use

Perkins recommend that all DEF taken from storage should be checked to ensure that the DEF meets ISO standard 22241-1.

Materials compatibility

DEF is corrosive. Due to the corrosion caused, DEF must be stored in tanks constructed of approved materials. Recommended storage materials:

Stainless Steels:

- 304 (S30400)
- 304L (S30403)
- 316 (S31600)
- 316L (S31603)

Alloys and metals:

- Chromium Nickel (CrNi)
- Chromium Nickel Molybdenum (CrNiMo)
- Titanium

Non-metallic materials:

- Polyethylene
- Polypropylene
- Polyisobutylene
- Teflon (PFA)
- Polyfluoroethylene (PFE)
- Polyvinylidene fluoride (PVDF)
- Polytetrafluoroethylene (PTFE)

Materials NOT compatible with DEF solutions include Aluminum, Magnesium, Zinc, Nickel coatings, Silver, and Carbon steel and Solders containing any of the above. Unexpected reactions may occur if DEF solutions come in contact with any non-compatible material or unknown materials.

Maintenance Recommendations

i07819420

System Pressure Release

Coolant System

WARNING

Pressurized system: Hot coolant can cause serious burn. To open cap, stop engine, wait until radiator is cool. Then loosen cap slowly to relieve the pressure.

WARNING

When the engine is in the AUTOMATIC mode, the engine can start at any moment. To avoid personal injury, always remain clear of the the engine when the engine is in the AUTOMATIC mode.

The engine can have the ability to auto start. Ensure that the power supply is isolated before any service or repair is performed.

To relieve the pressure from the coolant system, turn off the engine. Allow the cooling system pressure cap to cool. Remove the cooling system pressure cap slowly to relieve pressure.

Fuel System

To relieve the pressure from the fuel system, turn off the engine.

High-Pressure Fuel Lines

WARNING

Contact with high pressure fuel may cause fluid penetration and burn hazards. High pressure fuel spray may cause a fire hazard. Failure to follow these inspection, maintenance and service instructions may cause personal injury or death.

The high-pressure fuel lines are the fuel lines that are between the high-pressure fuel pump and the high-pressure fuel manifold and the fuel lines that are between the fuel manifold and the fuel injectors.

The high-pressure fuel lines are different from fuel lines on other fuel systems, the differences are as follows:

- The high-pressure fuel lines are constantly charged with high pressure.
- The internal pressures of the high-pressure fuel lines are higher than other types of fuel system.

Before any service or repair is performed on the engine fuel lines, perform the following tasks:

1. Stop the engine.
2. Wait for 10 minutes.

Do not loosen the high-pressure fuel lines to remove air from the fuel system.

Engine Oil

To relieve pressure from the lubricating system, turn off the engine.

i07915408

Welding on Engines with Electronic Controls

NOTICE

Because the strength of the frame may decrease, some manufacturers do not recommend welding onto a chassis frame or rail. Consult the OEM of the equipment or your Perkins dealer regarding welding on a chassis frame or rail.

Correct welding procedures are necessary to avoid damage to the engines ECM, sensors, and associated components. When possible, remove the component from the unit and then weld the component. If removal of the component is not possible, the following procedure must be followed when you weld on a unit equipped with an Electronic Engine. The following procedure is considered to be the safest procedure to weld on a component. This procedure should provide a minimum risk of damage to electronic components.

NOTICE

Do not ground the welder to electrical components such as the ECM or sensors. Improper grounding can cause damage to the drive train bearings, hydraulic components, electrical components, and other components.

Clamp the ground cable from the welder to the component that will be welded. Place the clamp as close as possible to the weld. This will help reduce the possibility of damage.

Note: Perform the welding in areas that are free from explosive hazards.

Maintenance Section
Welding on Engines with Electronic Controls

1. Stop the engine. Turn the switched power to the OFF position.
2. Ensure that the fuel supply to the engine is turned off.
3. Disconnect the negative battery cable from the battery. If a battery disconnect switch is provided, open the switch.
4. Disconnect all electronic components from the wiring harnesses. Include the following components:
 - Electronic components for the driven equipment
 - ECM
 - Sensors
 - Electric operated fuel pump
 - Electronically controlled valves
 - Relays
 - Aftertreatment ID module

NOTICE

Do not use electrical components (ECM or ECM sensors) or electronic component grounding points for grounding the welder.

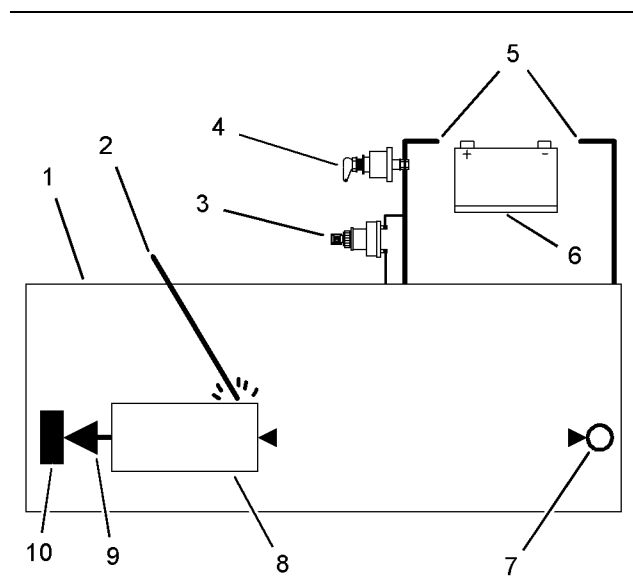

Illustration 71

g06477753

Use the example above. The current flow from the welder to the ground clamp of the welder will not damage any associated components.

- (1) Engine
- (2) Welding electrode
- (3) Keyswitch in the OFF position
- (4) Battery disconnect switch in the open position
- (5) Disconnected battery cables
- (6) Battery
- (7) Electrical/Electronic component
- (8) The component that is being welded
- (9) Current path of the welder
- (10) Ground clamp for the welder

5. Connect the welding ground cable directly to the part that will be welded. Place the ground cable as close as possible to the weld to reduce the possibility of welding current damage to the following components. Bearings, hydraulic components, electrical components, and ground straps.

Note: If electrical/electronic components are used as a ground for the welder, or electrical/electronic components are located between the welder ground and the weld, current flow from the welder could severely damage the component.

6. Protect the wiring harness from welding debris and spatter.
7. Use standard welding practices to weld the materials.

i07014325

Severe Service Application

Severe service is the application of an engine that either exceeds the current published standards for that engine range. Or results in the engine being used at the extremes of certain operating conditions.

- Performance such as power range, speed range, and fuel consumption
- Fuel quality
- Operational Altitude
- Maintenance intervals
- Oil selection and maintenance
- Coolant type and maintenance
- Environmental qualities
- Installation
- The temperature of the fluid in the engine

Refer to the standards for the engine or consult your Perkins distributor to determine if the engine is operating within the defined parameters.

Severe service operation can accelerate component wear. Engines that operate under severe conditions may need more frequent maintenance intervals to ensure maximum reliability and retention of full service life.

Due to individual applications, identification is not possible for all the factors which can contribute to severe service operation. Consult your Perkins distributor for the unique maintenance that is necessary for the engine.

The operating environment, incorrect operating procedures, and incorrect maintenance procedures can be factors which contribute to a severe service application.

Environmental Factors

Ambient temperatures – The engine may be exposed to extended operation in extremely cold environments or hot environments. Valve components can be damaged by carbon buildup if the engine is frequently started and stopped in very cold temperatures. Extremely hot intake air reduces engine performance.

Quality of the air – The engine may be exposed to extended operation in an environment that is dirty or dusty, unless the equipment is cleaned regularly. Mud, dirt, and dust can encase components.

Maintenance can be very difficult. The buildup can contain corrosive chemicals.

Buildup – Compounds, elements, corrosive chemicals, and salt can damage some components.

Altitude – Problems can arise when the engine is operated at altitudes that are higher than the intended settings for that application. Necessary adjustments should be made.

Incorrect Operating Procedures

- Extended operation at low idle
- Frequent hot shutdowns
- Operating at excessive loads
- Operating at excessive speeds
- Operating outside the intended application

Incorrect Maintenance Procedures

- Extending the maintenance intervals
- Failure to use recommended fuel, lubricants, and coolant/antifreeze

i10210765

Maintenance Interval Schedule

When Required

- “ Diesel Exhaust Fluid Tank - Flush“ 138
- “ Battery - Replace“ 116
- “ Battery or Battery Cable - Disconnect“ 117
- “ DEF Filler Screen (Emission Related Component) - Clean“ 132
- “ Diesel Exhaust Fluid (Emission Related Component) - Fill“ 136
- “ Engine - Clean“ 140
- “ Engine Air Cleaner Element - Replace“ 141
- “ Engine Oil Sample - Obtain“ 145
- “ Fuel System - Prime“ 151

Daily

- “ Coolant Level - Check“ 131
- “ Driven Equipment - Check“ 140
- “ Engine Air Cleaner Service Indicator - Inspect“ 143
- “ Engine Air Precleaner - Check/Clean“ 144
- “ Engine Oil Level - Check“ 144

Every Week

- “ Hoses and Clamps - Inspect/Replace“ 158

Every 50 Service Hours

- “ Fuel Tank Water and Sediment - Drain“ 157

Every 500 Service Hours or 1 Year

- “ Battery Electrolyte Level - Check“ 117
- “ Engine Air Cleaner Element - Replace“ 141
- “ Engine Oil and Filter - Change“ 146
- “ Fan Clearance - Check“ 150
- “ Fuel System Primary Filter (Water Separator) Element - Replace“ 152
- “ Fuel System Secondary Filter - Replace“ 156

- “ Radiator - Clean“ 159

Every 1000 Service Hours

- “ Belt - Inspect“ 118
- “ Belt Tensioner - Check“ 118
- “ Water Pump - Inspect“ 162

Every 2000 Service Hours

- “ Aftercooler Core - Inspect“ 116
- “ Alternator - Inspect“ 116
- “ Engine Mounts - Inspect“ 144
- “ Radiator Mounts - Inspect“ 159
- “ Starting Motor - Inspect“ 160

Every 3000 Service Hours

- “ Alternator and Fan Belts - Replace“ 116

“ Diesel Exhaust Fluid Filter (Emission Related Component) - Replace” 137

Every 3000 Service Hours or 1 Year

“ Coolant (Commercial Heavy-Duty) - Change“ .. 123

Every 3000 Service Hours or 2 Years

“ Coolant (Commercial Heavy-Duty) - Change“ .. 119

Every 4000 Service Hours

“ Aftercooler Core - Clean/Test“ 116

Every 4500 Service Hours

“ Turbocharger - Inspect“ 160

Every 6000 Service Hours

“ Diesel Exhaust Fluid Injector (Emission Related Component) - Replace“ 138

Every 6000 Service Hours or 3 Years

“ Coolant (ELC) - Change“ 127

Every 10 000 Service Hours

“ DEF Manifold Filters (Emission Related Component) - Replace“ 134

i01807350

Aftercooler Core - Clean/Test (Air-To-Air Aftercooler)

The air-to-air aftercooler is OEM installed in many applications. Please refer to the OEM specifications for information that is related to the aftercooler.

i02322295

Aftercooler Core - Inspect

Note: Adjust the frequency of cleaning according to the effects of the operating environment.

Inspect the aftercooler for these items: damaged fins, corrosion, dirt, grease, insects, leaves, oil and other debris. Clean the aftercooler, if necessary.

For air-to-air aftercoolers, use the same methods that are used for cleaning radiators.

WARNING

Personal injury can result from air pressure.

Personal injury can result without following proper procedure. When using pressure air, wear a protective face shield and protective clothing.

Maximum air pressure at the nozzle must be less than 205 kPa (30 psi) for cleaning purposes.

After cleaning, start the engine and accelerate the engine to high idle rpm. This will help in the removal of debris and drying of the core. Stop the engine. Use a light bulb behind the core in order to inspect the core for cleanliness. Repeat the cleaning, if necessary.

Inspect the fins for damage. Bent fins may be opened with a "comb".

Note: If parts of the aftercooler system are repaired or replaced, a leak test is highly recommended.

Inspect these items for good condition: Welds, mounting brackets, air lines, connections, clamps and seals. Make repairs, if necessary.

i02322311

Alternator - Inspect

Perkins recommends a scheduled inspection of the alternator. Inspect the alternator for loose connections and correct battery charging. Check the ammeter (if equipped) during engine operation in order to ensure correct battery performance and/or correct performance of the electrical system. Make repairs, as required.

Check the alternator and the battery charger for correct operation. If the batteries are correctly charged, the ammeter reading should be very near zero. All batteries should be kept charged. The batteries should be kept warm because temperature affects the cranking power. If the battery is too cold, the battery will not crank the engine. When the engine is not run for long periods of time or if the engine is run for short periods, the batteries may not fully charge. A battery with a low charge will freeze more easily than a battery with a full charge.

i02680137

Alternator and Fan Belts - Replace

Refer to Disassembly and Assembly Manual, "Alternator Belt - Remove and Install".

i05425759

Battery - Replace

WARNING

Batteries give off combustible gases which can explode. A spark can cause the combustible gases to ignite. This can result in severe personal injury or death.

Ensure proper ventilation for batteries that are in an enclosure. Follow the proper procedures in order to help prevent electrical arcs and/or sparks near batteries. Do not smoke when batteries are serviced.

⚠ WARNING

The battery cables or the batteries should not be removed with the battery cover in place. The battery cover should be removed before any servicing is attempted.

Removing the battery cables or the batteries with the cover in place may cause a battery explosion resulting in personal injury.

1. Switch the engine to the OFF position. Remove all electrical loads.

Note: After the engine has stopped, allow 2 minutes in order for the diesel exhaust fluid lines to be purged before disconnecting the power.

2. Turn off any battery chargers. Disconnect any battery chargers.
3. Ensure that the battery disconnect switch is in the OFF position.
4. Disconnect the NEGATIVE “-” cable from the NEGATIVE “-” battery terminal.
5. Disconnect the POSITIVE “+” cable from the POSITIVE “+” battery terminal.

Note: Always recycle a battery. Never discard a battery. Dispose of used batteries to an appropriate recycling facility.

6. Remove the used battery.
7. Install the new battery.

Note: Before the cables are connected, ensure that the battery disconnect switch is in the OFF position.

8. Connect the POSITIVE “+” cable to the POSITIVE “+” battery terminal.
9. Connect the NEGATIVE “-” cable to the NEGATIVE “-” battery terminal.
10. Turn the battery disconnect switch to the ON position.

i02747977

Battery Electrolyte Level - Check

When the engine is not run for long periods of time or when the engine is run for short periods, the batteries may not fully recharge. Ensure a full charge in order to help prevent the battery from freezing. If batteries are correctly charged, the ammeter reading should be very near zero, when the engine is in operation.

⚠ WARNING

All lead-acid batteries contain sulfuric acid which can burn the skin and clothing. Always wear a face shield and protective clothing when working on or near batteries.

1. Remove the filler caps. Maintain the electrolyte level to the “FULL” mark on the battery.

If the addition of water is necessary, use distilled water. If distilled water is not available use clean water that is low in minerals. Do not use artificially softened water.

2. Check the condition of the electrolyte with a suitable battery tester.
3. Install the caps.
4. Keep the batteries clean.

Clean the battery case with one of the following cleaning solutions:

- Use a solution of 0.1 kg (0.2 lb) baking soda and 1 L (1 qt) of clean water.
- Use a solution of ammonium hydroxide.

Thoroughly rinse the battery case with clean water.

i05424317

Battery or Battery Cable - Disconnect

⚠ WARNING

The battery cables or the batteries should not be removed with the battery cover in place. The battery cover should be removed before any servicing is attempted.

Removing the battery cables or the batteries with the cover in place may cause a battery explosion resulting in personal injury.

1. Turn the start switch to the OFF position. Turn the ignition switch (if equipped) to the OFF position and remove the key and all electrical loads.

Note: After the engine has stopped, allow 2 minutes in order for the diesel exhaust fluid lines to be purged before disconnecting the power.

2. Disconnect the negative battery terminal. Ensure that the cable cannot contact the terminal. When four 12 V batteries are involved, 2 negative connections must be disconnected.
3. Remove the positive connection.
4. Clean all disconnected connection and battery terminals.
5. Use a fine grade of sandpaper to clean the terminals and the cable clamps. Clean the items until the surfaces are bright or shiny. DO NOT remove material excessively. Excessive removal of material can cause the clamps to fit incorrectly. Coat the clamps and the terminals with a suitable silicone lubricant or petroleum jelly.
6. Tape the cable connections in order to help prevent accidental starting.
7. Proceed with necessary system repairs.
8. In order to connect the battery, connect the positive connection before the negative connector.

i07380538

Belt - Inspect

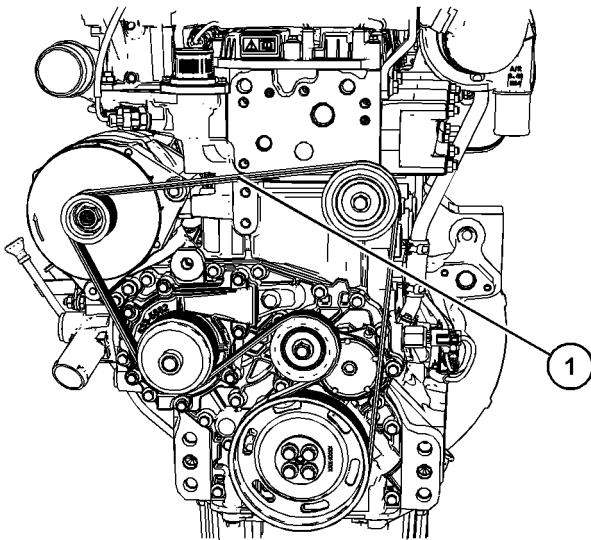

Illustration 72

g06301080

Typical example

To maximize the engine performance, inspect the belt (1) for wear and for cracking. Replace the belt if the belt is worn or damaged.

- Inspect the belt for cracks, splits, glazing, grease, displacement of the cord and evidence of fluid contamination.

The belt must be replaced if the following conditions are present.

- The belt has a crack in more than one rib.
- More than one section of the belt is displaced in one rib of a maximum length of 50.8 mm (2 inch).

To replace the belt, refer to Disassembly and Assembly, "Alternator Belt - Remove and Install". If necessary, replace the belt tensioner. Refer to Disassembly and Assembly, "Alternator Belt - Remove and Install" for the correct procedure.

i07382084

Belt Tensioner - Check

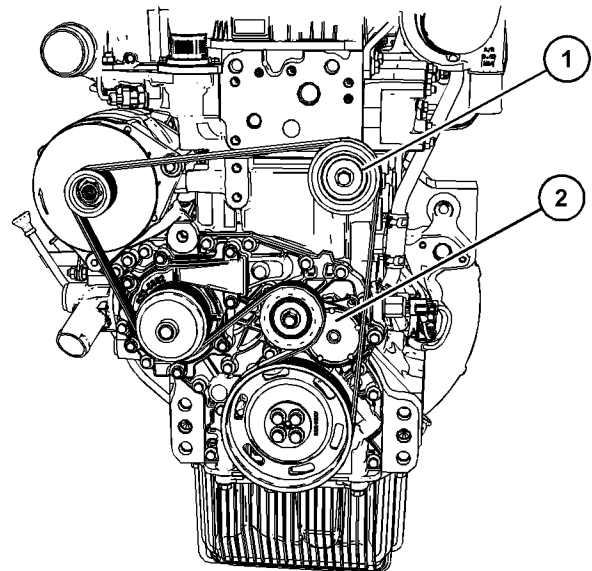

Illustration 73

g06302365

Typical example

1. Remove the belt. Refer to Disassembly and Assembly, "Alternator Belt - Remove and Install".
2. Ensure that the belt tensioner (2) is securely installed. Visually inspect the belt tensioner for damage. Check that the pulley on the tensioner rotates freely and that the bearing is not loose.
3. Some engines have an idler pulley (2). Ensure that the idler pulley is securely installed. Visually inspect the idler pulley for damage. Ensure that the idler pulley can rotate freely and that the bearing is not loose.

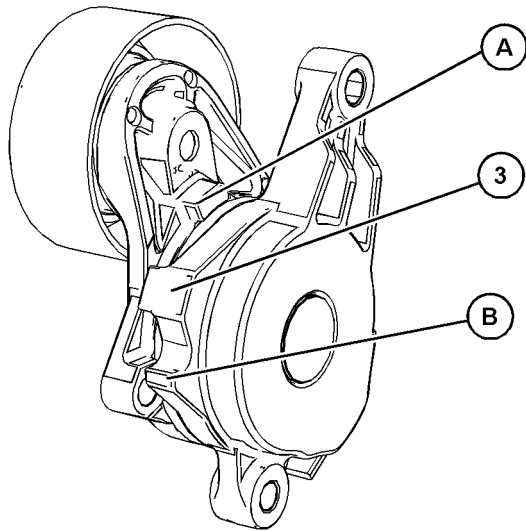

Illustration 74

g06302436

Typical example

- (A) Tensioner stop
- (3) Tensioner body stop
- (B) Tensioner stop

4. Ensure that the tensioner has full movement of travel from stop (A) the other stop (B). Using a constant force the tensioner should move smoothly between the tensioner stop and the tensioner body stop.
5. If necessary, replace damaged components.

Install the belt. Refer to Disassembly and Assembly, "Alternator Belt - Remove and Install".

i09953178

Coolant (Commercial Heavy-Duty) - Change

Note: This procedure is for coolants that meets a commercial heavy-duty coolant specification of "ASTM D6210".

Clean the cooling system and flush the cooling system before the recommended maintenance interval if the following conditions exist:

- The engine overheats frequently.
- Foaming is observed.
- The oil has entered the cooling system and the coolant is contaminated.

- The fuel has entered the cooling system and the coolant is contaminated.

NOTICE

When any servicing or repair of the engine cooling system is performed, the procedure must be performed with the engine on level ground. Level ground will allow you to check accurately the coolant level. This procedure will also help in avoiding the risk of introducing an air lock into the coolant system.

Note: Inspect the water pump and the water temperature regulator after the cooling system has been drained. This inspection is a good opportunity to replace the water pump, the water temperature regulator, and the hoses, if necessary.

Drain

WARNING

Pressurized System: Hot coolant can cause serious burns. To open the cooling system filler cap, stop the engine and wait until the cooling system components are cool. Loosen the cooling system pressure cap slowly in order to relieve the pressure.

1. Stop the engine and allow the engine to cool. Loosen the cooling system filler cap slowly to relieve any pressure. Remove the cooling system filler cap.

Note: Refer to Operation and Maintenance Manual, "General Hazard Information" for information on Containing Fluid Spillage.

Maintenance Section
Coolant (Commercial Heavy-Duty) - Change

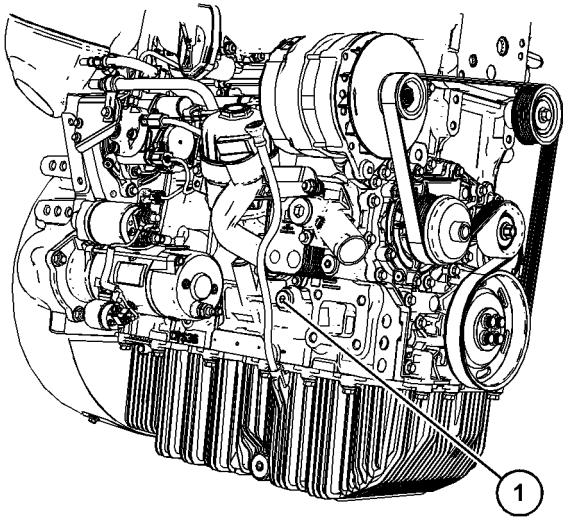

Illustration 75

g06302798

Typical example

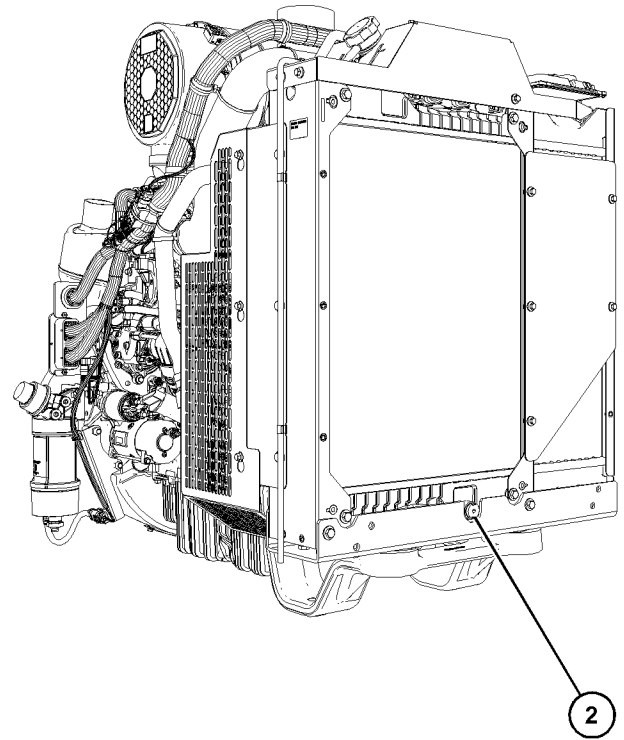

Illustration 77

g07668766

Typical example of a 904J-E36TA ElectropaK

2. Remove drain plug (1) on the engine. Remove the drain plug (2) on the radiator.

Allow the coolant to drain into a suitable container.

3. Properly dispose of the drained material. Obey local regulations for the disposal of the material.

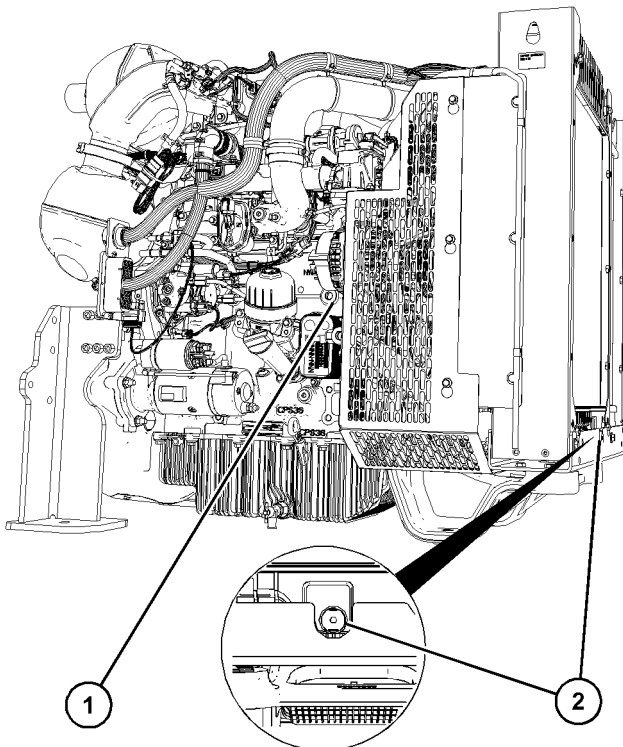

Illustration 76

g06742584

Typical example of a 904J-E36TA Industrial Open Power Unit (IOPU)

Drain Plugs for IOPU Radiators

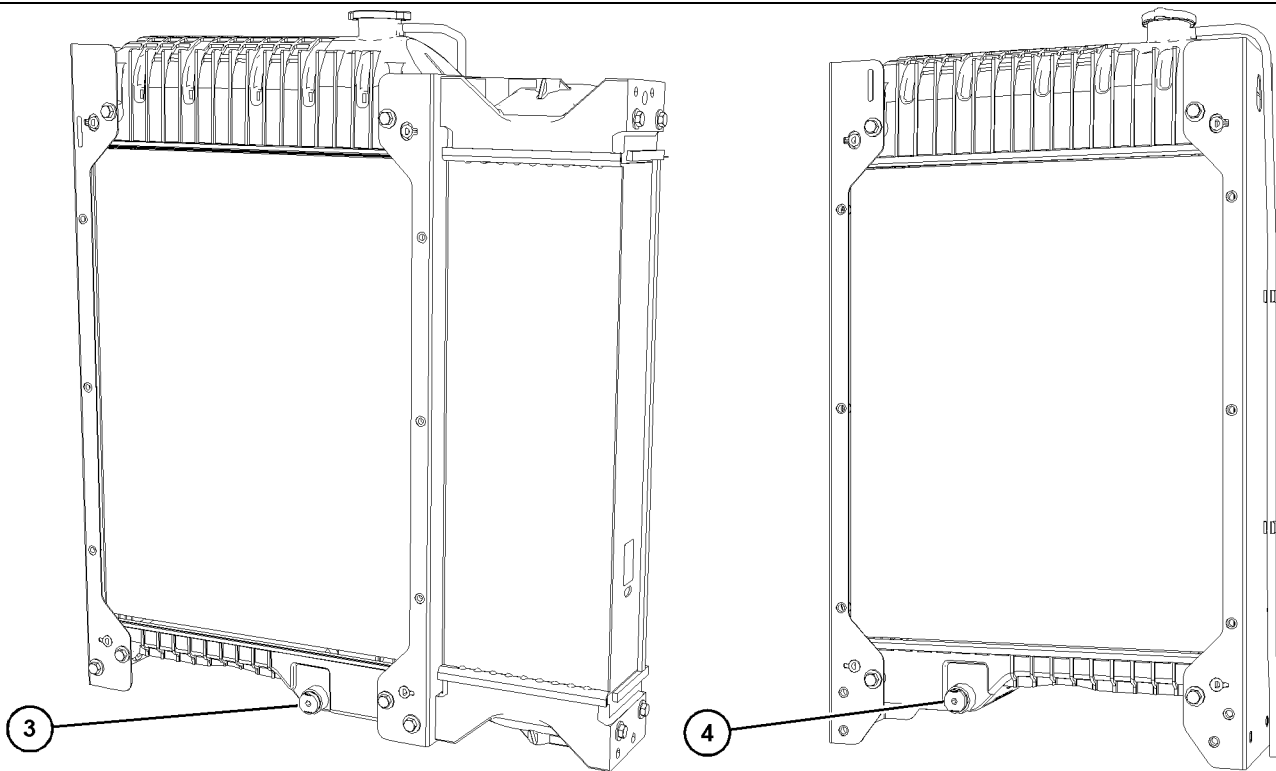

Illustration 78

g06742657

Typical example

(3) 904J-E36TA IOPU radiator drain plug

(4) 904J-E28T IOPU radiator drain plug

- Tighten drain plug (3) to a torque of 4 N·m (35.4 lb in)
- Tighten drain plug (4) to a torque of 4 N·m (35.4 lb in)

Drain Plug for ElectropaK Radiator

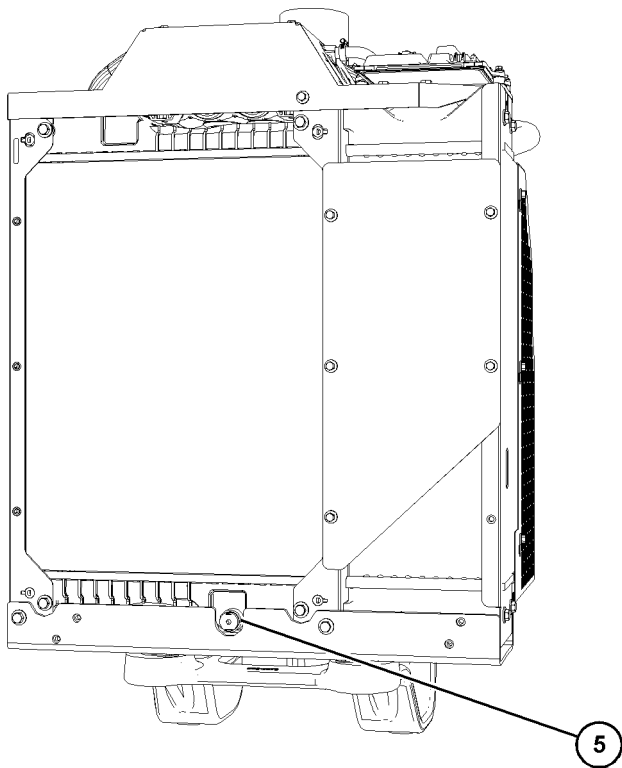

Illustration 79

g07668878

Typical example of ElectropaK Radiator

(5) 904J-E36TA ElectropaK radiator drain plug

Tighten drain plug (5) to a torque of 4 N·m
(35.4 lb in)

Flush

NOTICE

Cleaning agents for an industrial cooling system must not be used. These cleaning agents are very aggressive and cause damage to the cooling system components.

1. Flush the cooling system with clean water and a suitable cleaning agent to remove any debris. Refer to your Perkins dealer or distributor for suitable cleaning agents.
2. Clean the drain plugs. Install the drain plugs. Tighten drain plug securely.

NOTICE

Do not fill the cooling system faster than 5 L (1.3 US gal) per minute to avoid air locks.

Cooling system air locks may result in engine damage.

3. Fill the cooling system with clean water and install the cooling system filler cap.
4. Start and run the engine at low idle for a minimum of 30 minutes. The coolant temperature should be at least 82 °C (180 °F).

NOTICE

Improper or incomplete rinsing of the cooling system can result in damage to copper and other metal components.

To avoid damage to the cooling system, make sure to completely flush the cooling system with clear water. Continue to flush the system until all signs of the cleaning agent are gone.

5. Stop the engine and allow the engine to cool. Loosen the cooling system filler cap slowly to relieve any pressure. Remove the cooling system filler cap. Remove the connection hose or remove the cooling system drain plugs. Allow the water to drain. Flush the cooling system with clean water. Install the connection hose.
6. Install the drain plugs and tighten securely.

Fill

NOTICE

Do not fill the cooling system faster than 5 L (1.3 US gal) per minute to avoid air locks.

Cooling system air locks may result in engine damage.

1. Fill the cooling system with the coolant/antifreeze. Refer to this Operation and Maintenance Manual, "Refill Capacities and Recommendations" topic (Maintenance Section) for more information on cooling system specifications. Do not install the cooling system filler cap.
2. Start and run the engine at low idle. Increase the engine rpm to high idle. Operate the engine to open the engine thermostat. This operation will allow any air in the system to be purged. Decrease the engine speed to low idle. Stop the engine.
3. Maintain the coolant level at the maximum mark that is correct for your application.

4. Clean the cooling system filler cap. Inspect the gasket that is on the cooling system filler cap. If the gasket that is on the cooling system filler cap is damaged, discard the old cooling system filler cap and install a new cooling system filler cap. If the gasket that is on the cooling system filler cap is not damaged, perform a pressure test. If the cooling system filler cap does not retain the correct pressure, install a new cooling system filler cap.
5. Start the engine. Inspect the cooling system for leaks and for the correct operating temperature.

i09953231

Coolant (Commercial Heavy-Duty) - Change

Note: This procedure is for coolants that meets a commercial heavy-duty coolant specification of "ASTM D4985" .

Clean the cooling system and flush the cooling system before the recommended maintenance interval if the following conditions exist:

- The engine overheats frequently.
- Foaming is observed.
- The oil has entered the cooling system and the coolant is contaminated.
- The fuel has entered the cooling system and the coolant is contaminated.

NOTICE

When any servicing or repair of the engine cooling system is performed, the procedure must be performed with the engine on level ground. Level ground will allow you to check accurately the coolant level. This procedure will also help in avoiding the risk of introducing an air lock into the coolant system.

Note: Inspect the water pump and the water temperature regulator after the cooling system has been drained. This inspection is a good opportunity to replace the water pump, the water temperature regulator, and the hoses, if necessary.

Drain

WARNING

Pressurized System: Hot coolant can cause serious burns. To open the cooling system filler cap, stop the engine and wait until the cooling system components are cool. Loosen the cooling system pressure cap slowly in order to relieve the pressure.

1. Stop the engine and allow the engine to cool. Loosen the cooling system filler cap slowly to relieve any pressure. Remove the cooling system filler cap.

Note: Refer to Operation and Maintenance Manual, "General Hazard Information" for information on Containing Fluid Spillage.

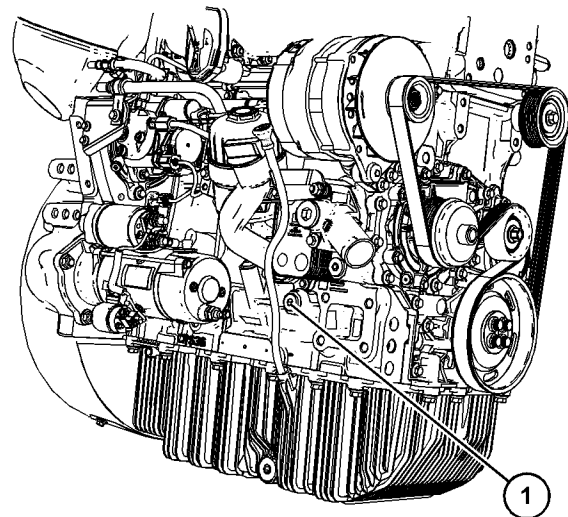

Illustration 80

g06302798

Typical example

Maintenance Section
Coolant (Commercial Heavy-Duty) - Change

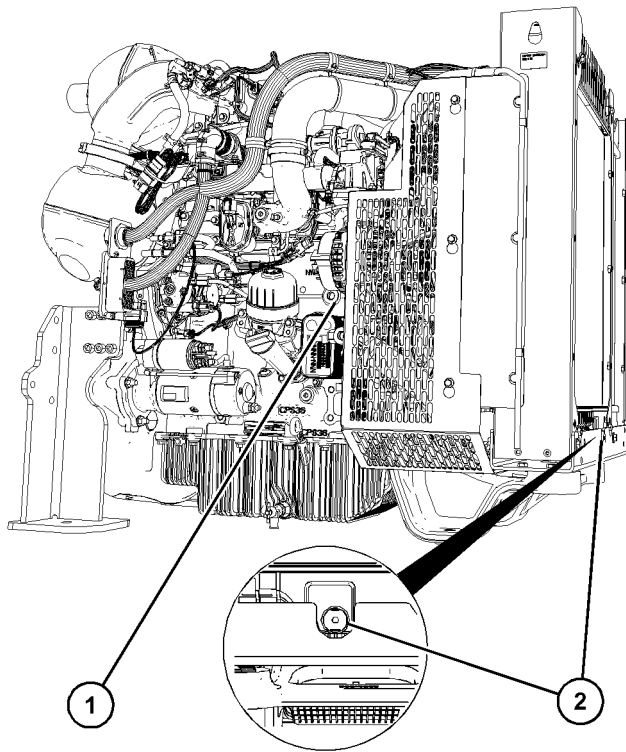

Illustration 81 g06742584
Typical example of a 904J-E36TA Industrial Open Power Unit (IOPU)

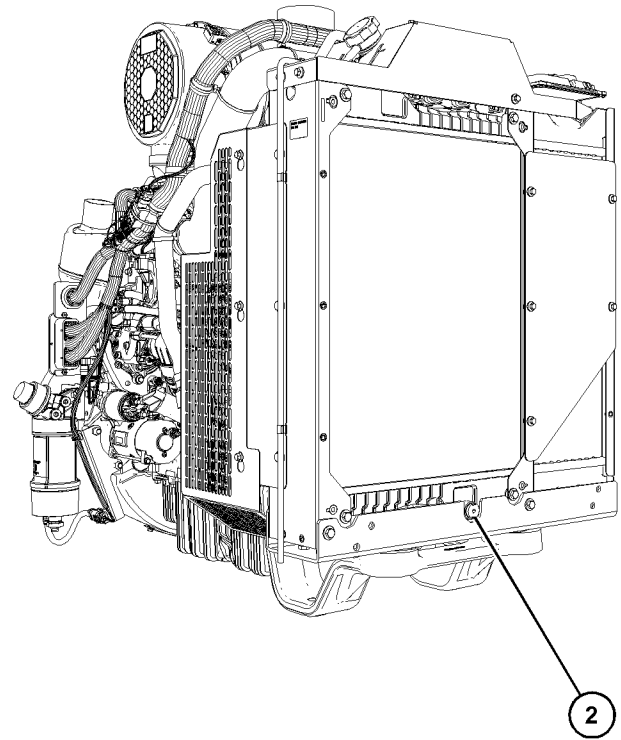

Illustration 82 g07668766
Typical example of a 904J-E36TA ElectropaK

2. Remove drain plug (1) on the engine. Remove the drain plug (2) on the radiator.
Allow the coolant to drain into a suitable container.
3. Properly dispose of the drained material. Obey local regulations for the disposal of the material.

Drain Plugs for IOPU Radiators

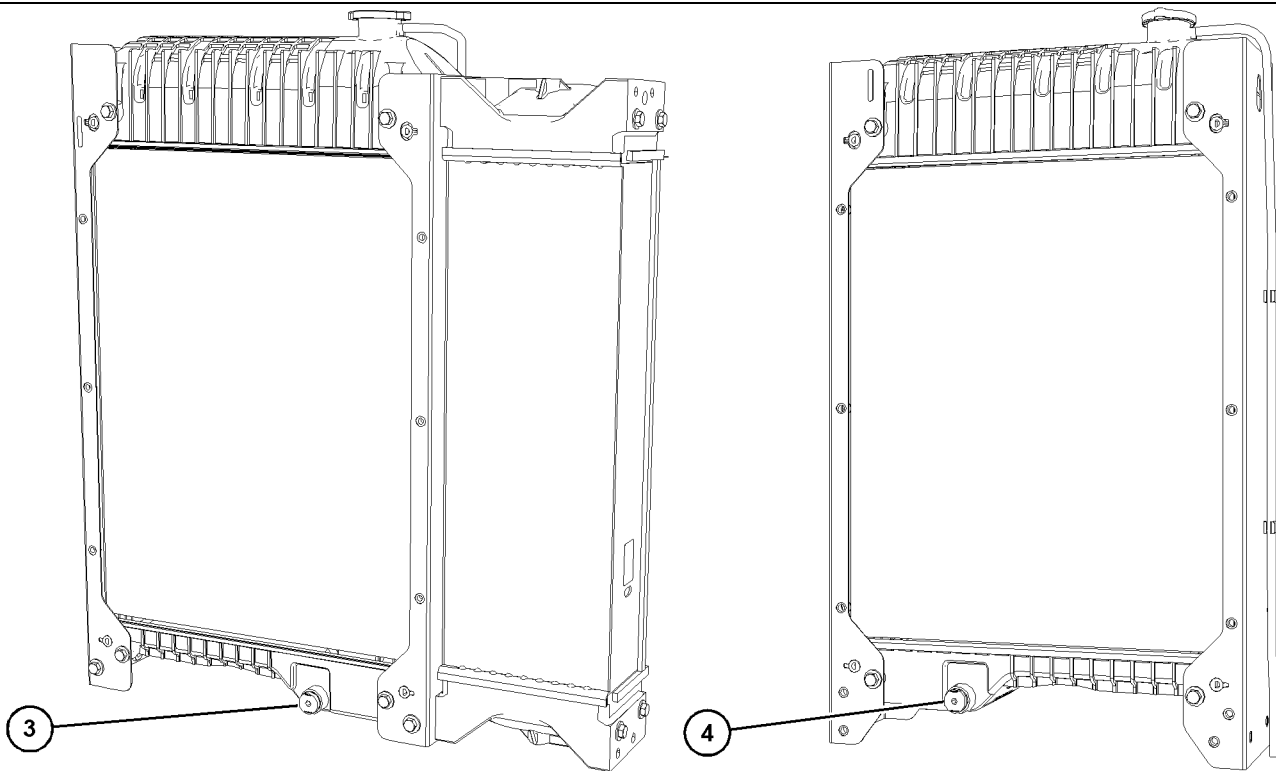

Illustration 83

g06742657

Typical example

(3) 904J-E36TA IOPU radiator drain plug

(4) 904J-E28T IOPU radiator drain plug

- Tighten drain plug (3) to a torque of 4 N·m (35.4 lb in)
- Tighten drain plug (4) to a torque of 4 N·m (35.4 lb in)

Drain Plug for ElectropaK Radiator

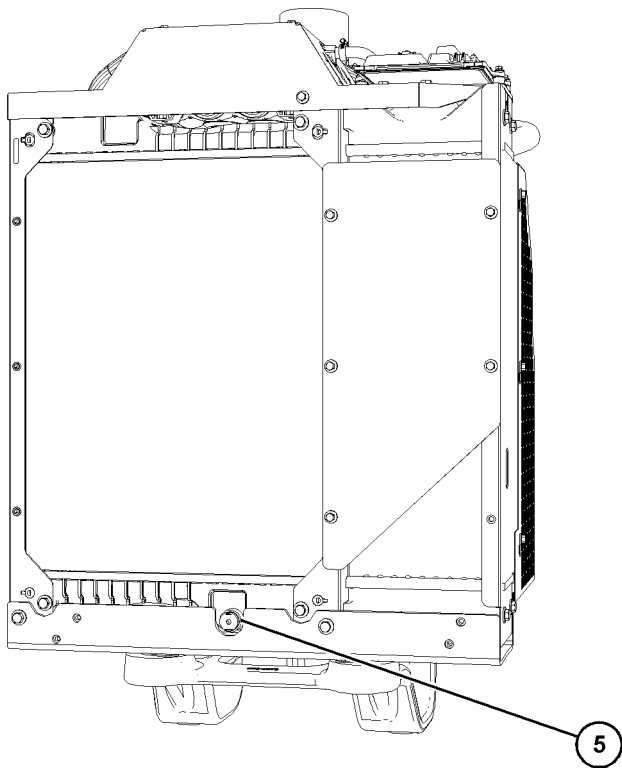

Illustration 84

g07668878

Typical example of ElectropaK Radiator

(5) 904J-E36TA ElectropaK radiator drain plug

Tighten drain plug (5) to a torque of 4 N·m
(35.4 lb in)

Flush

NOTICE

Cleaning agents for an industrial cooling system must not be used. These cleaning agents are very aggressive and cause damage to the cooling system components.

1. Flush the cooling system with clean water and a suitable cleaning agent to remove any debris. Refer to your Perkins distributor for suitable cleaning agents.
2. Clean the drain plugs. Install the drain plugs. Tighten drain plug securely.

NOTICE

Do not fill the cooling system faster than 5 L (1.3 US gal) per minute to avoid air locks.

Cooling system air locks may result in engine damage.

3. Fill the cooling system with clean water and install the cooling system filler cap.
4. Start and run the engine at low idle for a minimum of 30 minutes. The coolant temperature should be at least 82 °C (180 °F).

NOTICE

Improper or incomplete rinsing of the cooling system can result in damage to copper and other metal components.

To avoid damage to the cooling system, make sure to completely flush the cooling system with clear water. Continue to flush the system until all signs of the cleaning agent are gone.

5. Stop the engine and allow the engine to cool. Loosen the cooling system filler cap slowly to relieve any pressure. Remove the cooling system filler cap. Remove the cooling system drain plugs. Allow the water to drain. Flush the cooling system with clean water.
6. Install all drain plugs and tighten securely.

Fill

NOTICE

Do not fill the cooling system faster than 5 L (1.3 US gal) per minute to avoid air locks.

Cooling system air locks may result in engine damage.

1. Fill the cooling system with the coolant/antifreeze. Refer to this Operation and Maintenance Manual, "Refill Capacities and Recommendations" topic (Maintenance Section) for more information on cooling system specifications. Do not install the cooling system filler cap.
2. Start and run the engine at low idle. Increase the engine rpm to high idle. Operate the engine to open the engine thermostat. This operation will allow any air in the system to be purged. Decrease the engine speed to low idle. Stop the engine.
3. Maintain the coolant level at the maximum mark that is correct for your application. Refer to this Operation and Maintenance Manual, "Coolant Level - Check" for more information.

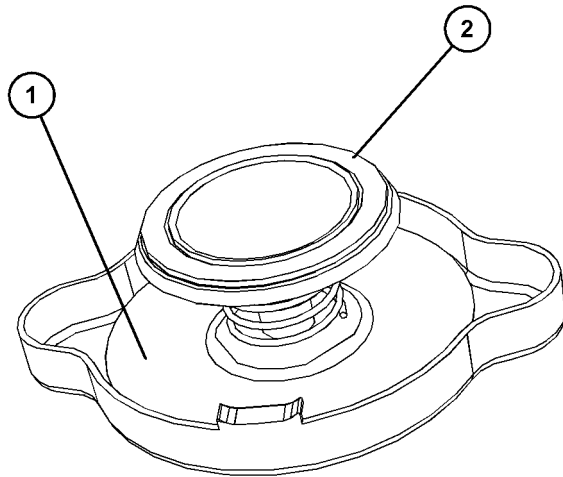

Illustration 85

g06165279

Typical example

4. Clean the cooling system filler cap and check the condition of the filler cap gasket (2). Replace the cooling system filler cap if the filler cap gasket (2) and sealing surface (1) are damaged. If the cooling system filler cap is not damaged, perform a pressure test on the filler cap.

- Radiator cap pressure for four cylinder engine 110 kPa (15.9 psi)

If the cooling system filler cap passes the pressure test check, install the filler cap. If required install new cooling system filler cap.

5. Start the engine. Inspect the cooling system for leaks and for the correct operating temperature.

i09953237

Coolant (ELC) - Change

Clean the cooling system and flush the cooling system before the recommended maintenance interval if the following conditions exist:

- The engine overheats frequently.
- Foaming is observed.
- The oil has entered the cooling system and the coolant is contaminated.
- The fuel has entered the cooling system and the coolant is contaminated.

Note: Use non-foaming detergent to clean oil or fuel contamination.

Note: When the cooling system is cleaned, only clean water is needed when the ELC is drained and replaced.

Note: Inspect the water pump and the water temperature regulator after the cooling system has been drained. Replace the water pump, the water temperature regulator, and the hoses, if necessary.

NOTICE

Service or repair of the engine cooling system must be performed on level ground. The engine must be level to check the coolant level. The engine must be level to avoid the risk of introducing an air lock into the coolant system.

Drain

WARNING

Pressurized System: Hot coolant can cause serious burns. To open the cooling system filler cap, stop the engine and wait until the cooling system components are cool. Loosen the cooling system pressure cap slowly in order to relieve the pressure.

1. Stop the engine and allow the engine to cool. Loosen the cooling system filler cap slowly to relieve any pressure. Remove the cooling system filler cap.

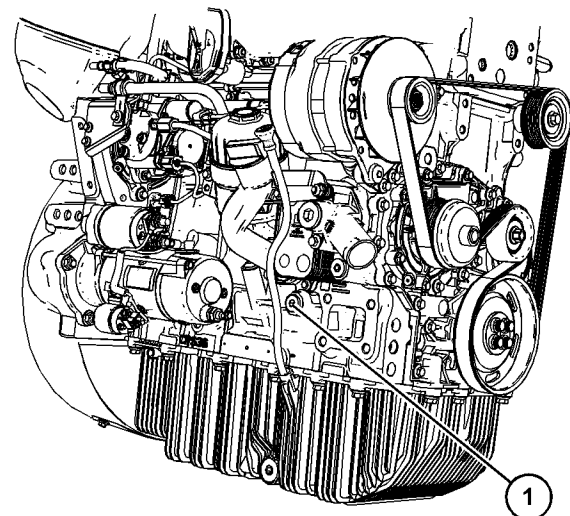

Illustration 86

g06302798

Typical example

Maintenance Section
Coolant (ELC) - Change

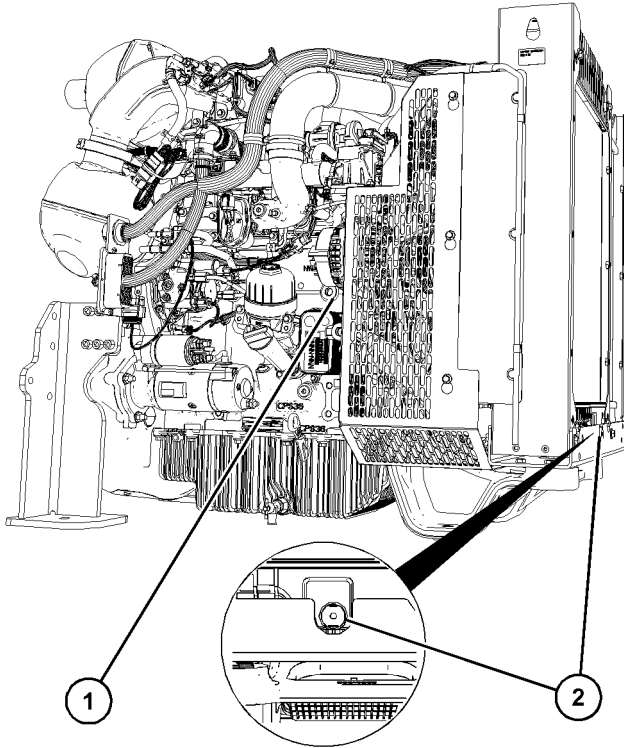

Illustration 87

g06742584

Typical example of a 904J-E36TA Industrial Open Power Unit (IOPU)

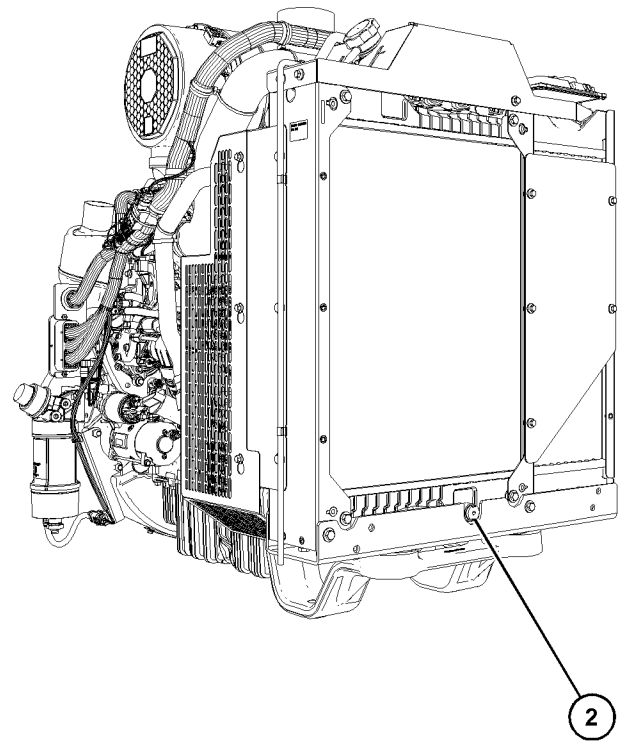

Illustration 88

g07668766

Typical example of a 904J-E36TA ElectropaK

2. Remove drain plug (1) on the engine. Remove the drain plug (2) on the radiator.

Allow the coolant to drain into a suitable container.

For information regarding the disposal and the recycling of used coolant, consult your Perkins distributor.

Drain Plugs for IOPU Radiators

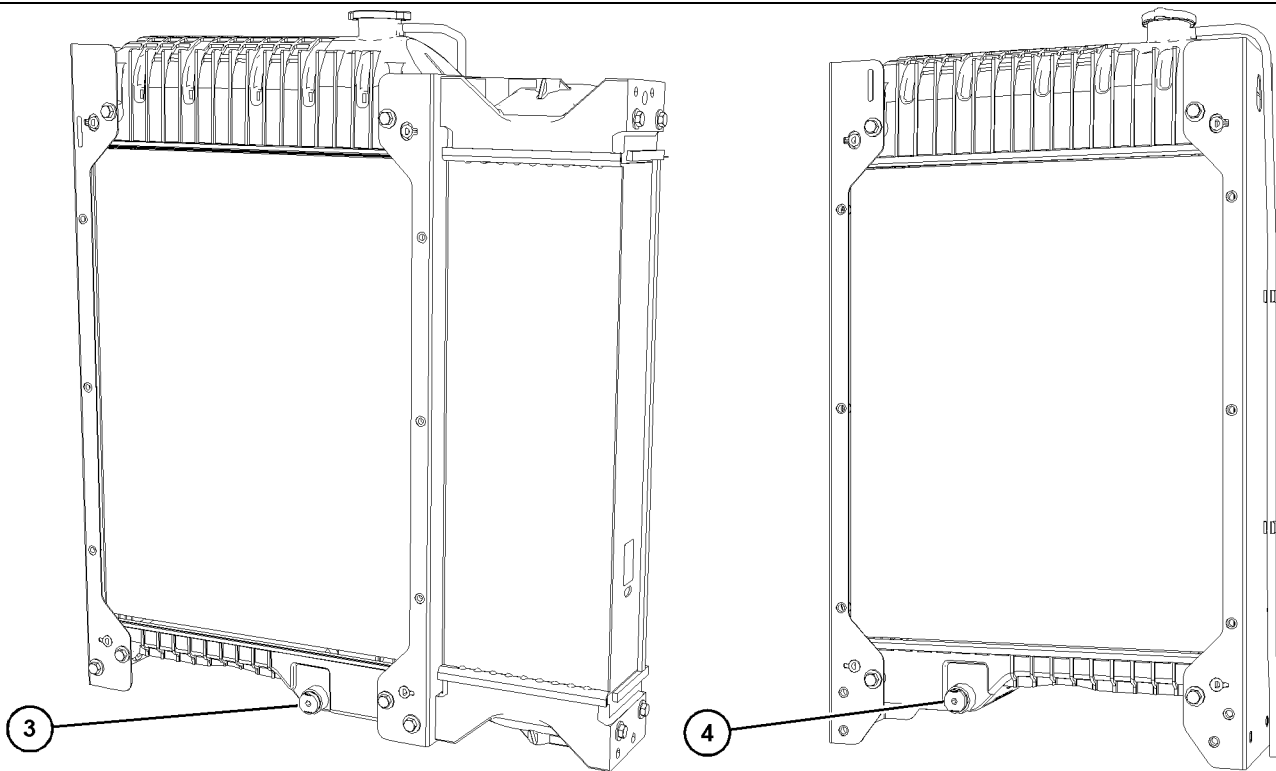

Illustration 89

g06742657

Typical example

(3) 904J-E36TA IOPU radiator drain plug

(4) 904J-E28T IOPU radiator drain plug

- Tighten drain plug (3) to a torque of 4 N·m (35.4 lb in)
- Tighten drain plug (4) to a torque of 4 N·m (35.4 lb in)

Drain Plug for ElectropaK Radiator

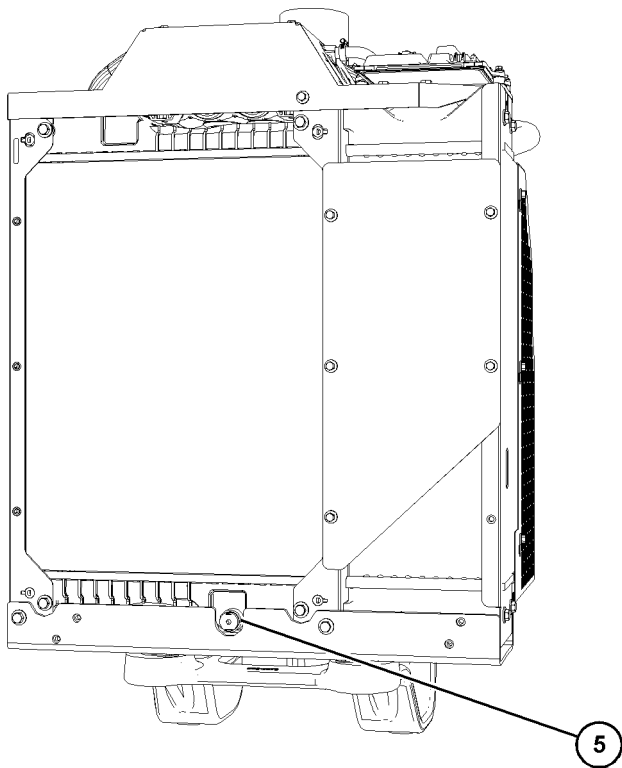

Illustration 90

g07668878

Typical example of ElectropaK Radiator

(5) 904J-E36TA ElectropaK radiator drain plug

Tighten drain plug (5) to a torque of 4 N·m
(35.4 lb in)

Flush

NOTICE

Cleaning agents for an industrial cooling system must not be used. These cleaning agents are very aggressive and cause damage to the cooling system components.

1. Flush the cooling system with distilled or deionized water to remove any debris.
2. Clean the drain plugs and install the drain plugs. Tighten the drain plugs securely.

NOTICE

Do not fill the cooling system faster than 5 L
(1.3 US gal) per minute to avoid air locks.

Cooling system air locks may result in engine damage.

3. Fill the cooling system with distilled or deionized water. Install the cooling system filler cap.
4. Start and run the engine at low idle for a minimum of 30 minutes. The coolant temperature should be at least 82 °C (180 °F).
5. Stop the engine and allow the engine to cool. Loosen the cooling system filler cap slowly to relieve any pressure. Remove the cooling system filler cap. Remove the cooling system drain plugs. Allow the water to drain. Flush the cooling system with clean water.
6. Install the drain plugs and tighten securely.

Fill

NOTICE

Do not fill the cooling system faster than 5 L
(1.3 US gal) per minute to avoid air locks.

Cooling system air locks may result in engine damage.

1. Fill the cooling system with Extended Life Coolant (ELC). Refer to this Operation and Maintenance Manual, "Refill Capacities" topic (Maintenance Section) for more information on cooling system specifications. Do not install the cooling system filler cap.
2. Start and run the engine at low idle. Increase the engine rpm to high idle. Operate the engine to open the engine thermostat. An open thermostat will allow any air in the system to be purged. Decrease the engine speed to low idle. Stop the engine.
3. Maintain the coolant level at the maximum mark that is correct for your application. Refer to this Operation and Maintenance Manual, "Coolant Level - Check" for more information.

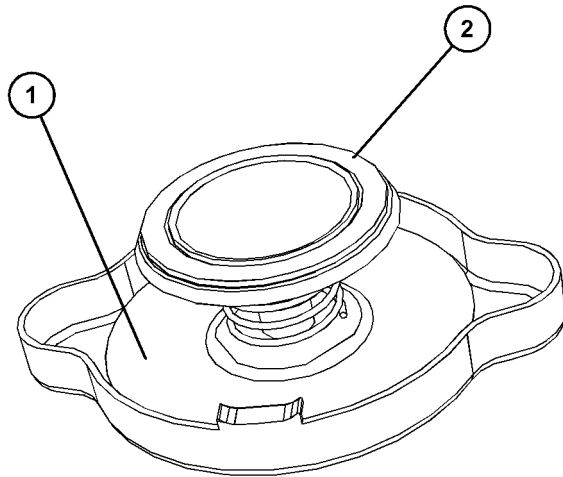

Illustration 91

g06165279

Typical example

4. Clean the cooling system filler cap and check the condition of the filler cap gasket (2). Replace the cooling system filler cap if the filler cap gasket (2) and sealing surface (1) are damaged. If the cooling system filler cap is not damaged, perform a pressure test on the filler cap.

The correct pressure for the cooling system filler cap is stamped on the face of the cooling system filler cap.

If the cooling system filler cap passes the pressure test check, install the filler cap. If required install new cooling system filler cap.

5. Start the engine. Inspect the cooling system for leaks and for proper operating temperature.

i09953242

Coolant Level - Check

WARNING

Pressurized System: Hot coolant can cause serious burns. To open the cooling system filler cap, stop the engine and wait until the cooling system components are cool. Loosen the cooling system pressure cap slowly in order to relieve the pressure.

Check the coolant level when the engine is stopped and cool.

NOTICE

When any servicing or repair of the engine cooling system is performed, the procedure must be performed with the engine on level ground. This procedure will allow you to check accurately the coolant level. This procedure will also help in avoiding the risk of introducing an air lock into the coolant system.

Remove the cooling system filler cap slowly to relieve the pressure within the cooling system.

For the correct coolant level, refer to the OEM information.

Radiator Cap

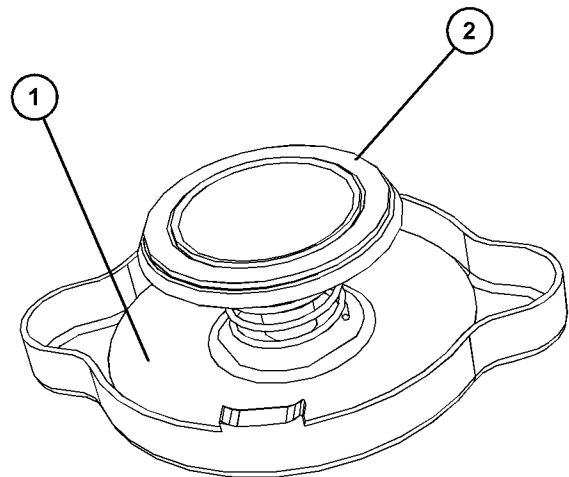

Illustration 92

g06165279

Typical example

Clean the cooling system filler cap and check the condition of the filler cap gasket (1). Replace the cooling system filler cap if the filler cap gasket (2) or the sealing surface (1) are damaged.

The radiator filler cap should be checked at regular intervals to insure that the filler cap relief pressure is correct. The cooling system fill cap pressure is 110 kPa (15.9 psi)

Reinstall the cooling system filler cap when all checks are complete.

Industrial Open Power Unit (IOPU) Radiators

The following information is provided for the correct coolant level on IOPU radiators.

Maintenance Section
DEF Filler Screen (Emission Related Component) - Clean

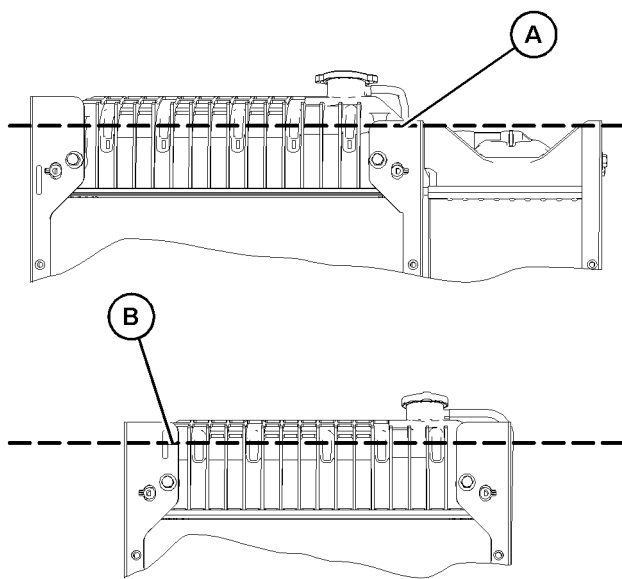

Illustration 93

g06743628

Typical example

- The coolant level (A) is for 904J-E36TA IOPU radiator.
- The coolant level (B) is for 904J-E28T IOPU radiator.

1. Remove the cooling system filler cap slowly to relieve the pressure within the cooling system.
2. The coolant level (A) and (B) is 61.5 mm (2.42 inch) below the top of the radiator neck.
3. Check the cooling system filler cap and install.

Coolant level 904J-E36TA ElectropaK Radiator

The following information is provided for the correct coolant level on ElectropaK radiators.

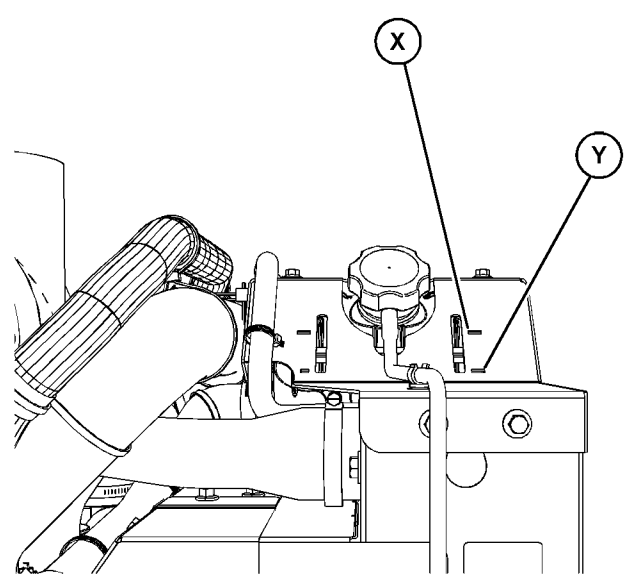

Illustration 94

g07668474

Typical example

The coolant level on 904J-E36TA ElectropaK radiator is to be between maximum level (X) and minimum level (Y).

i10201333

DEF Filler Screen (Emission Related Component) - Clean

NOTICE

Ensure that the engine is stopped before any servicing or repair is performed.

NOTICE

Care must be taken to ensure that Diesel Exhaust Fluid (DEF) is contained during performance of inspection, maintenance, testing, adjusting, and repair.

Type 1 DEF filler Screen

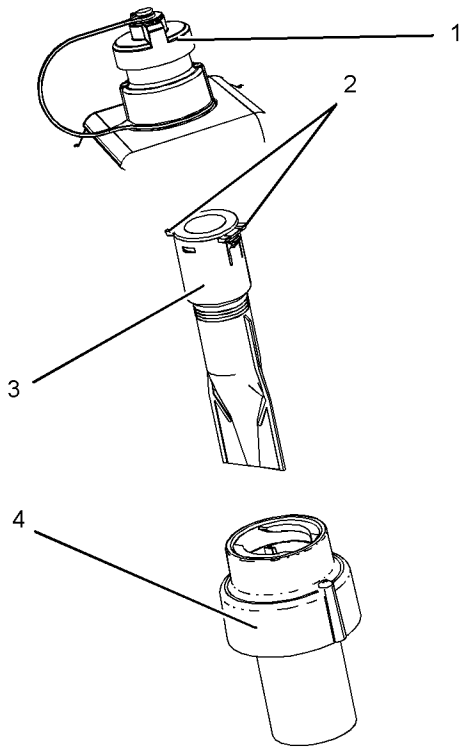

Illustration 95

g03725939

Typical example of Type 1 Filler Screen

1. Ensure that the area around cap on the Diesel Exhaust Fluid (DEF) tank (5) is clean. Remove cap (1).
2. Using a suitable tool, press the tabs (2) to release the tabs. With the tabs released remove the filler screen (3) from DEF tank neck adapter (4).
3. The filler screen can be cleaned in clean water and dried using compressed air. Refer to this Operation and Maintenance Manual, "General Hazard Information" for information on using compressed air.
4. If the filler screen cannot be cleaned or the filler screen is damaged, then the filler screen must be replaced.

5. Install filler screen (3) into DEF tank neck adapter (4). Press filler screen into neck adapter and ensure that tabs (2) are located correctly. Install cap (1).

Type 2 DEF Filler Screen

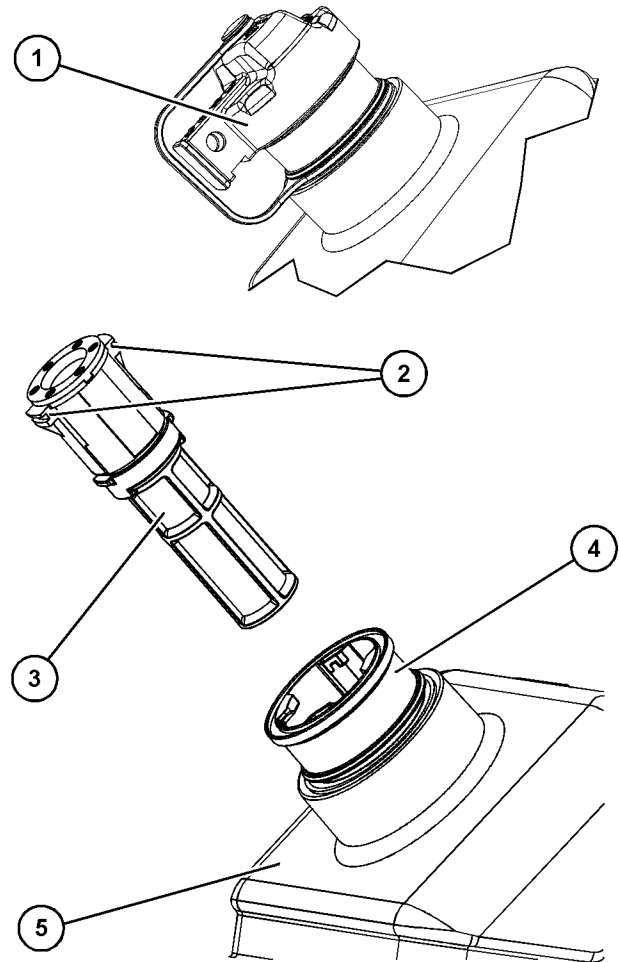

Illustration 96

g07794596

Typical example of Type 2 Filler Screen

1. Ensure that the area around cap on the Diesel Exhaust Fluid (DEF) tank is clean. Remove cap (1).
2. Using a suitable tool, press the tabs (2) to release the tabs. With the tabs released remove the filler screen (3) from DEF tank neck adapter (4).
3. The filler screen can be cleaned in clean water and dried using compressed air. Refer to this Operation and Maintenance Manual, "General Hazard Information" for information on using compressed air.

4. If the filler screen cannot be cleaned or the filler screen is damaged, then the filler screen must be replaced.
5. Install filler screen (3) into DEF tank neck adapter (4). Press filler screen into neck adapter and ensure that tabs (2) are located correctly. Install cap (1).

i10208217

DEF Manifold Filters (Emission Related Component) - Replace

NOTICE

Ensure that the engine is stopped before any servicing or repair is performed.

NOTICE

Care must be taken to ensure that Diesel Exhaust Fluid (DEF) for the system is contained during performance of inspection, maintenance, testing, adjusting, and repair of the product. Be prepared to collect the fluid with suitable containers before opening any compartment or disassembling any component containing fluids.

Dispose of all fluids according to local regulations and mandates.

Ensure that the area around the DEF manifold is free from contamination before any servicing or repair is performed.

Type 1 Manifold (DEF Heater)

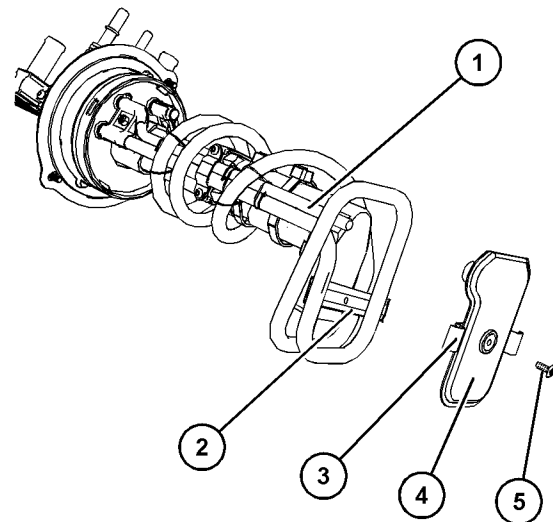

Illustration 97

g06302888

Typical example

1. Remove DEF tank manifold. Refer to Disassembly and Assembly, Manifold (DEF Heater) - Remove and Install for more information.
2. Remove screw (5) and remove filter (4) and bracket (3) and bracket (2) from assembly (1). Discard old filter.
3. Ensure that new filter (4) is clean and free from damage.
4. Place bracket (2) onto assembly (1). Install bracket (3) onto assembly (1).
5. Align new filter (4) to assembly suction pipe (1) and install new filter (4). Install screw (5) and tighten to a torque of 2 N·m (16 lb in).
6. Install DEF manifold, refer to Disassembly and Assembly, Manifold (DEF Heater) - Remove and Install for more information.

Type 2 Manifold (DEF Heater)

1. Remove the manifold, refer to Disassembly and Assembly, "Manifold (DEF Heater) - Remove and Install" for the correct procedure.

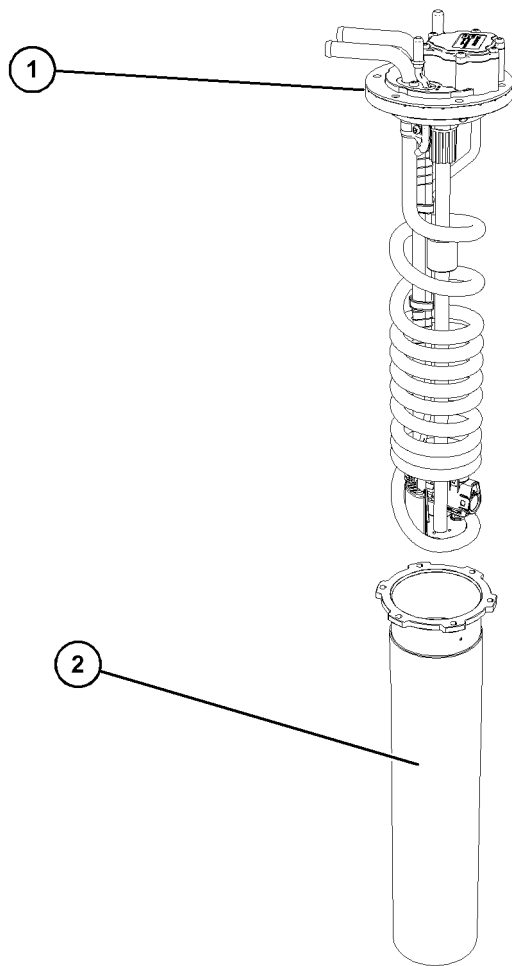

Illustration 98

g07722286

2. Remove outer filter (2) from DEF manifold (1). Discard the old outer filter (2).

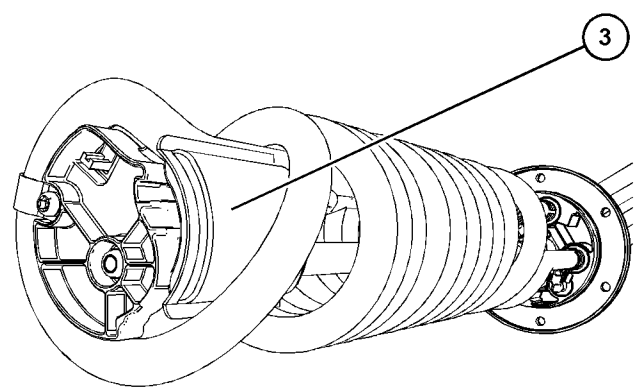

Illustration 99

g07722287

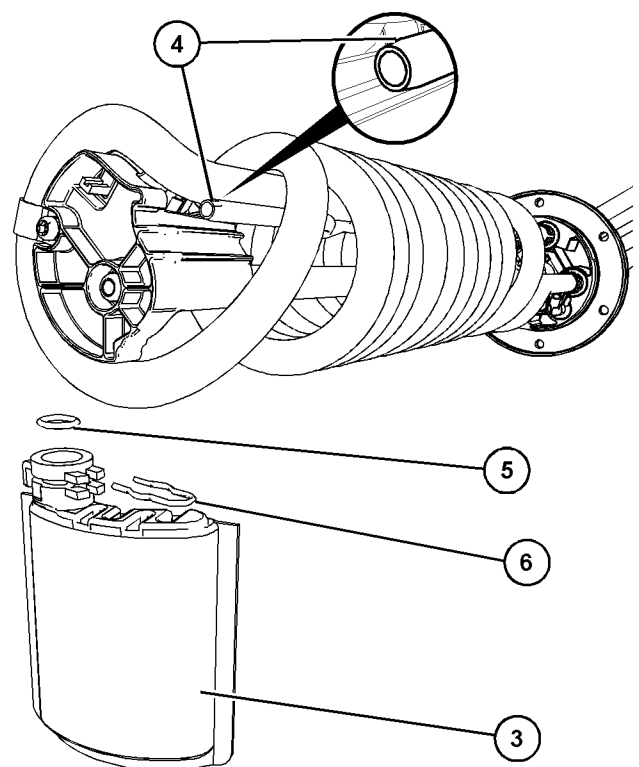

Illustration 100

g07722292

3. Pull locking clip (6) outwards and remove the DEF filter (3) from DEF pickup tube (4). Discard used DEF filter (3) and O-ring seal (5).
4. Visually check that a new O-ring seal (5) is in place on new DEF filter (3). Push the DEF filter (3) onto swage of the DEF pickup tube (4). Push locking clip (6) securely in place and ensure the DEF filter (3) is held in place.
5. Install new outer filter (2) on the DEF manifold (1).

6. Install the manifold, refer to Disassembly and Assembly, "Manifold (DEF Heater) - Remove and Install" for the correct procedure.

i07383319

Diesel Exhaust Fluid (Emission Related Component) - Fill

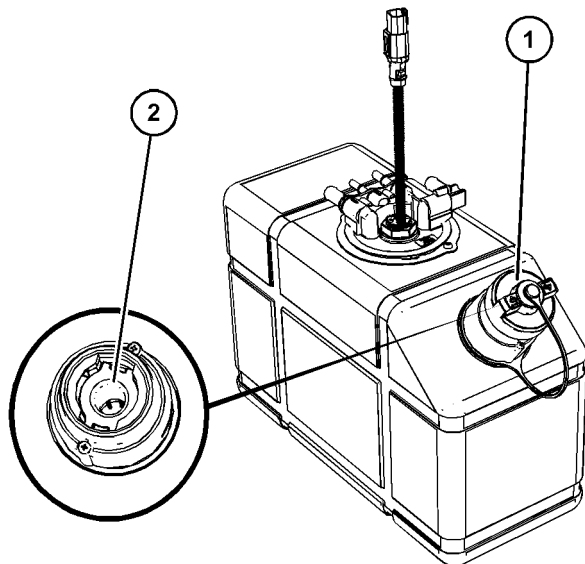

Illustration 101

g06303219

Typical example

Ensure that the correct specification Diesel Exhaust Fluid (DEF) is used. Ensure the cleanliness of the DEF, refer to this Operation and Maintenance Manual, "Fluid Recommendations" for more information.

Care should be taken when dispensing DEF. Spills should be cleaned immediately. All surfaces should be wiped clean and rinsed with water.

DEF that has been spilt will crystallize when the water within the liquid evaporates. Spilt DEF will attack paint and metal. If DEF is spilt, wash the area with water.

Caution should be used when dispensing DEF near an engine that has recently been running. Spilling DEF onto hot components may cause the release of ammonia vapors. Do not breathe ammonia vapors. Do not clean up any spills with bleach.

Ensure that the DEF tank is full before starting work.

1. Before filling the DEF tank, ensure that the DEF lines have been purged. Purging of the DEF lines will take place, after the engine has stopped. Only after the DEF lines have purged, should the DEF tank be filled. For more information on the time taken for purging the DEF lines, refer to this Operation and Maintenance Manual, "Battery Disconnect Switch".
2. Ensure that the DEF cap (1) and the surrounding area are clean and free from dirt. Ensure that all equipment use in filling the tank is clean and free from dirt.
3. Remove the DEF cap from the tank.
4. Fill the tank with the required amount of DEF. Ensure that dirt is not introduced into the tank during filling. Do not over fill the tank. The DEF will require room for expansion.

Note: Always fill the DEF tank on level ground. Cold weather can affect DEF, refer to this Operation and Maintenance Manual, "Diesel Exhaust Fluid in cold Weather" for more information.

5. The opening on the DEF tank (2) is a special diameter. Ensure that the correct nozzle is used when filling the DEF tank.

Note: At key on the DEF level gauge will show the last known DEF level and will transition to the new DEF level value.

6. Install the DEF cap. Check visually the DEF tank for leakage.

i07383609

Diesel Exhaust Fluid Filter (Emission Related Component) - Replace

⚠ WARNING

Personal injury can result from improper handling of chemicals.

Make sure you use all the necessary protective equipment required to do the job.

Make sure that you read and understand all directions and hazards described on the labels and material safety data sheet of any chemical that is used.

Observe all safety precautions recommended by the chemical manufacturer for handling, storage, and disposal of chemicals.

The Diesel Exhaust Fluid (DEF) pump can be located next to the DEF tank. On some application the DEF pump can be installed away from the DEF tank.

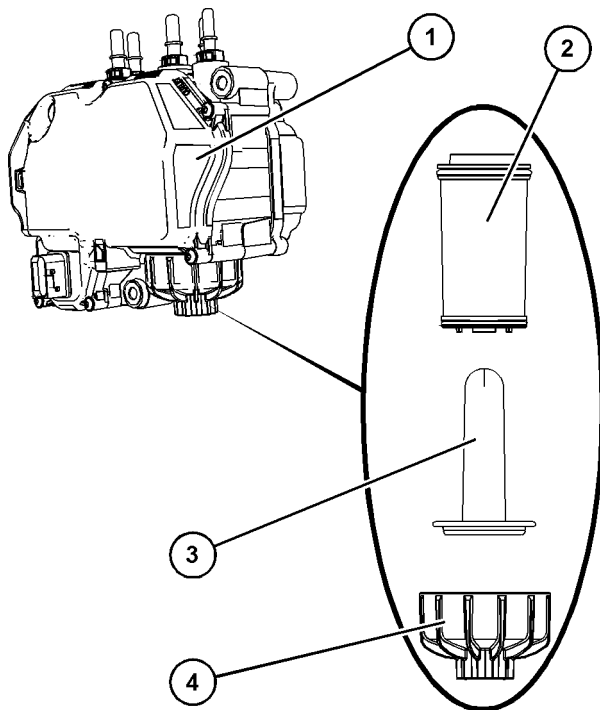

Illustration 102

g06303328

Typical example

1. Ensure that the area around the DEF filter is clean and free from dirt. Use a 27mm Bi-Hex socket to remove filter cap (4).
2. Remove the expansion device (3).

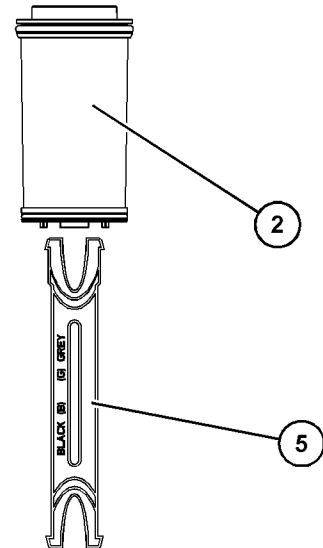

Illustration 103

g06215916

Typical example

3. Use supplied tool (5) to remove filter element (2) from DEF pump assembly (1).
4. Install new filter element (2) into DEF pump assembly (1).
5. Install expansion device (3) into filter element (2). Install filter cap (4) and tighten cap to 20 N·m (177 lb in).

i07385681

i10210007

Diesel Exhaust Fluid Injector (Emission Related Component) - Replace

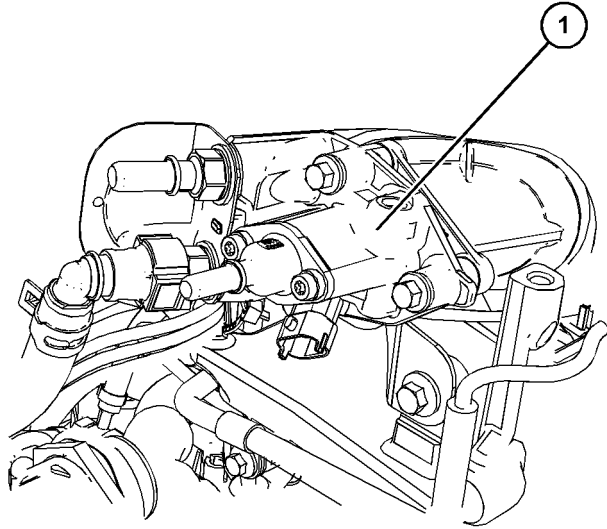

Illustration 104

g06304652

Typical example

For a detailed procedure to remove and install the DEF injector (1), refer to Disassembly and Assembly, DEF Injector and Mounting - Remove and Install.

After installation of the DEF injector, use the electronic service tool to perform the "DEF Dosing System Verification test".

Diesel Exhaust Fluid Tank - Flush

Required Tools

Table 35

Required Tools			
Tool	Part Number	Part Description	Qty
A	-	Plugs	2

Flushing Procedure

1. Turn the key switch to the OFF position. The key switch must be OFF to allow the Diesel Exhaust Fluid (DEF) pump to purge, ensuring the system is free of pressurized DEF.

Note: Allow the full 2 minutes after turning the key switch to the OFF position before turning the battery disconnect switch to the OFF position. In certain circumstances, allow for a maximum of 15 minutes after turning the key switch to the OFF position before turning the battery disconnect switch to the OFF position. Refer to Operation and Maintenance Manual, "Battery Disconnect Switch" for more information.

2. Position the suitable container under the DEF tank, drain the existing DEF from the tank.

Note: All DEF/ Distilled water drained or flushed during this procedure must be disposed of as per local regulations and mandates.

3. Drain the engine coolant to an appropriate level that will allow the coolant lines to be removed from the tank header. Refer to Operation and Maintenance Manual for more information.

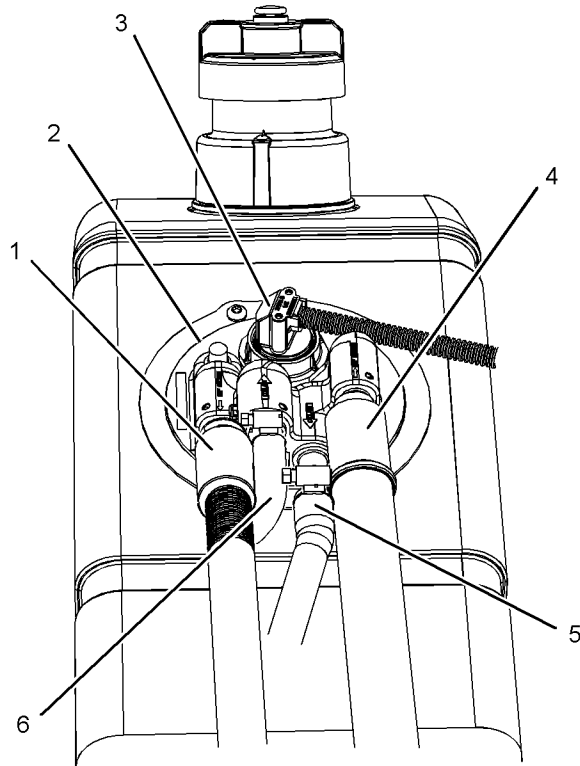

Illustration 105

g03708638

Typical example

- (1) DEF suction line
- (2) Manifold (DEF heater)
- (3) Harness assembly
- (4) DEF backflow line
- (5) Coolant return to the engine
- (6) Coolant supply to manifold (DEF heater)

4. Remove the manifold (DEF heater) from the DEF tank. Refer to Disassembly and Assembly, “Manifold (DEF Heater) - Remove and Install” for the correct procedure.

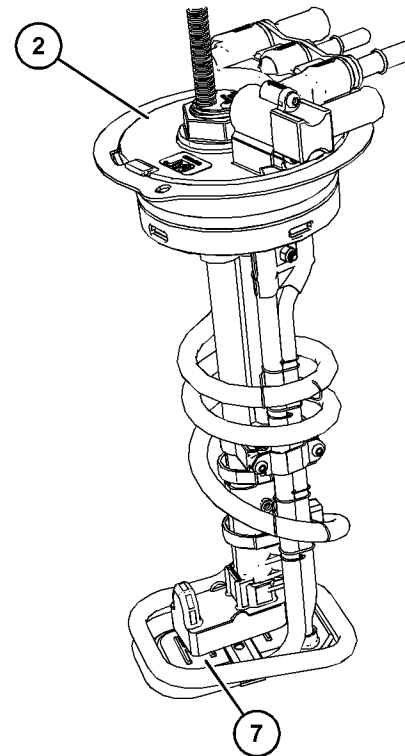

Illustration 106

g06357825

Typical example

- (2) Manifold (DEF heater)
- (7) Filter

- 5.** Remove the filter from the manifold (DEF heater). Refer to Operation and Maintenance Manual, “DEF Manifold Filters - Replace” for the correct procedure.
- 6.** Flush the DEF suction and backflow connections on the manifold (DEF heater) using distilled water. Install a new filter onto the manifold (DEF heater). Refer to Operation and Maintenance Manual, “DEF Manifold Filters - Replace” for the correct procedure.
- 7.** Position the suitable container under the DEF tank drain and flush the DEF tank thoroughly.

Note: To ensure that the tank is completely free of contaminants, it may be necessary to empty all residual fluids retained in the tank below the drain port level. To empty the tank completely, it may be necessary to remove the tank from the application. Refer to Disassembly and Assembly, “Diesel Exhaust Fluid Tank - Remove and Install” for the correct procedure. If contamination cannot be removed from any of the DEF system components, the affected components will require replacement. Refer to Disassembly and Assembly for information on removal and installation of the affected components.

8. Reinstall the manifold (DEF heater) into the DEF tank. Refer to Disassembly and Assembly, "Manifold (DEF Heater) - Remove and Install" for the correct procedure.
9. Replace any DEF system components that were removed due to contamination. Refer to Disassembly and Assembly for information on removal and installation of the affected components.

13. Fill the DEF tank to the appropriate level with new DEF. Operation and Maintenance Manual for more information. The new DEF must meet ISO 22241 standards.
14. Start the engine. Refer to Operation and Maintenance Manual for the correct procedure.
15. Connect to the electronic service tool.
16. Perform the "Aftertreatment System Functional Test" in the electronic service tool. This test will verify that the DEF system is working correctly following the flush and filter replacement.

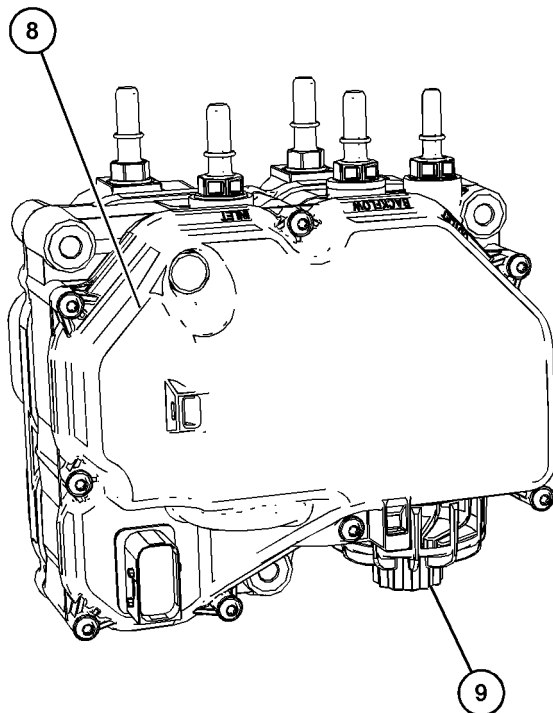

i02151646

Driven Equipment - Check

Refer to the OEM specifications for more information on the following maintenance recommendations for the driven equipment:

- Inspection
- Adjustment
- Lubrication
- Other maintenance recommendations

Perform any maintenance for the driven equipment which is recommended by the OEM.

i07819515

Engine - Clean

Illustration 107

g06357828

Typical example

- (8) DEF pump
(9) DEF filter cap

10. Replace the Diesel Exhaust Fluid (DEF) filter. Refer to Operation and Maintenance Manual, "Diesel Exhaust Fluid Filter - Replace" for the correct procedure.
11. Flush the DEF suction and backflow lines into a suitable container using distilled water. The minimum quantity of distilled water that is required is 7.57 L (2 US gal).
12. Reconnect all lines to the DEF pump and to the manifold (DEF heater). Refer to Disassembly and Assembly for the correct procedures.

WARNING

Personal injury or death can result from high voltage.

Moisture can create paths of electrical conductivity.

Make sure that the electrical system is OFF. Lock out the starting controls and tag the controls "DO NOT OPERATE" .

NOTICE

Accumulated grease and oil on an engine is a fire hazard. Keep the engine clean. Remove debris and fluid spills whenever a significant quantity accumulates on the engine.

Periodic cleaning of the engine is recommended. Steam cleaning the engine will remove accumulated oil and grease. A clean engine provides the following benefits:

- Easy detection of fluid leaks
- Maximum heat transfer characteristics
- Ease of maintenance

Note: Caution must be used to prevent electrical components from being damaged by excessive water when the engine is cleaned. Pressure washers and steam cleaners should not be directed at any electrical connectors or the junction of cables into the rear of the connectors. Avoid electrical components such as the alternator, the starter, and the ECM. Protect the fuel injection pump from fluids to wash the engine.

Ensure that care is taken that the safety labels, emission label, and all other information labels are not removed during engine cleaning.

Aftertreatment

During the engine cleaning process, ensure that water or cleaning fluids cannot enter the aftertreatment system. If cleaning fluids enters the aftertreatment system, damage could occur.

i09001187

Engine Air Cleaner Element - Replace

NOTICE

Never run the engine without an air cleaner element installed. Never run the engine with a damaged air cleaner element. Do not use air cleaner elements with damaged pleats, gaskets or seals. Dirt entering the engine causes premature wear and damage to engine components. Air cleaner elements help to prevent airborne debris from entering the air inlet.

NOTICE

Never service the air cleaner element with the engine running since this will allow dirt to enter the engine.

Servicing the Air Cleaner Elements

If the air cleaner element becomes plugged, the air can split the material of the air cleaner element. Unfiltered air will drastically accelerate internal engine wear.

- Check the precleaner (if equipped) and the dust bowl daily for accumulation of dirt and debris. Remove any dirt and debris, as needed.
- Operating in dirty conditions may require more frequent service of the air cleaner element.
- The air cleaner element should be replaced at least one time per year.

Replace the dirty air cleaner elements with clean air cleaner elements. Before installation, the new air cleaner elements should be thoroughly checked for tears and/or holes in the filter material. Inspect the gasket or the seal of the air cleaner element for damage. Maintain a supply of suitable air cleaner elements for replacement purposes.

Air Cleaners

Do not replace the air cleaner filter elements in a dirty environment, as dirt can enter the air system when the elements are removed.

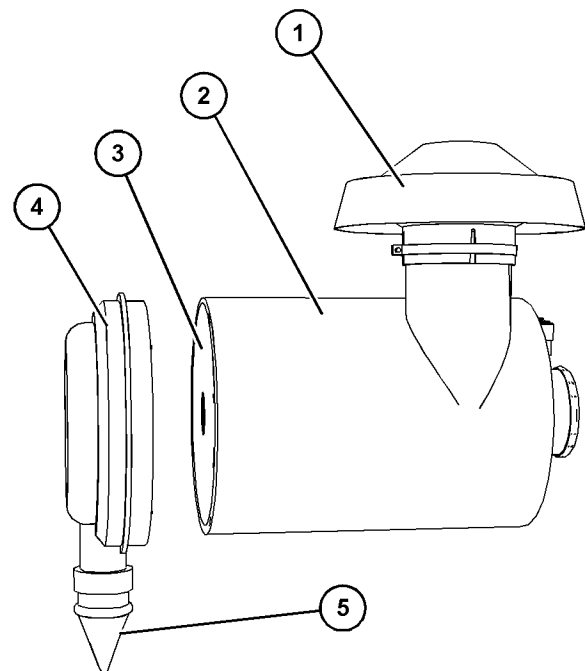

Illustration 108

g06217098

Typical example

- (1) Top Cover
- (2) Air Cleaner Body
- (3) Primary Air Filter Element
- (4) End Cover
- (5) Vacuum Valve

1. Ensure that the outer body of the air cleaner to be serviced is clean and free from dirt.

Maintenance Section
Engine Air Cleaner Element - Replace

2. Inspect the top cover (1) and if necessary remove top cover to clean cover. Ensure that dirt cannot enter the air cleaner system with top cover removed. If necessary, clean top cover and install.
3. Remove end cover (4) from air cleaner body (2). If necessary, clean end cover and ensure that the vacuum valve (5) is clean and free from dirt. Check the vacuum valve (5) for wear or damage, replace if necessary.
4. Remove primary air filter element (3) and if equipped, remove the secondary air filter element (Not Shown). Discard all old air filter elements.
5. If equipped, install new secondary air filter element (Not Shown) and install new primary air filter element (3).
6. Install end cover (4) to air cleaner body (2) and secure end cover. If necessary, reset the air service indicator, refer to this Operation and Maintenance Manual, Engine Air Cleaner Service Indicator - Inspect for more information.

Dual Element Air Cleaners

Some application can have dual elements. The dual air cleaner contains a primary air cleaner element and a secondary air cleaner element. Both element must be replaced at the same time.

Do not replace the air cleaner filter elements in a dirty environment, as dirt can enter the air system when the elements are removed.

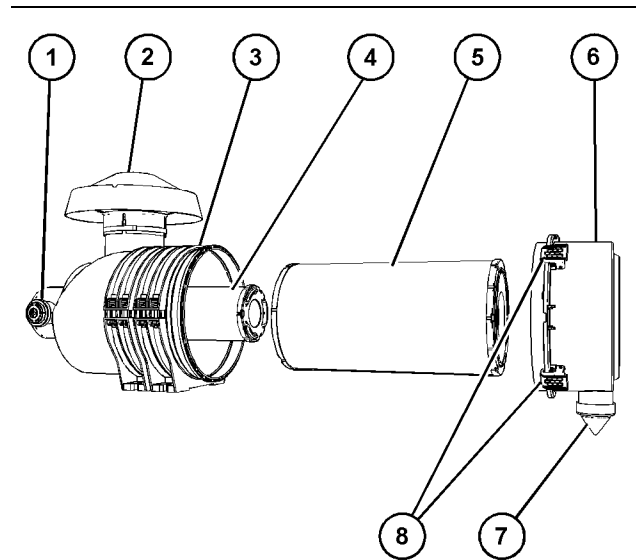

Illustration 109

g06966204

Typical example

- (1) Service Indicator
- (2) Top Cover
- (3) Air Cleaner Body
- (4) Primary Air Filter Element
- (5) Secondary Air Filter Element
- (6) End Cover
- (7) Vacuum Valve
- (8) Clips

1. Ensure that the outer body of the air cleaner to be serviced is clean and free from dirt.
2. Release clips (8) and remove end cover (6) from air cleaner body (3). If necessary, clean end cover and ensure that the valve (7) is clean and free from dirt. Check the valve (7) for wear or damage, replace if necessary.
3. Remove primary air filter element (5) and, remove the secondary air filter element (4). Discard all old air filter elements.
4. Install new secondary air filter element (4) and install new primary air filter element (5).

5. Install end cover (6) to air cleaner body (3) and secure end cover clips (8). If necessary, reset the air service indicator (1), refer to this Operation and Maintenance Manual, Engine Air Cleaner Service Indicator - Inspect for more information.

i09119853

Engine Air Cleaner Service Indicator - Inspect

Some engines may be equipped with a different service indicator.

Some engines are equipped with a differential gauge for inlet air pressure. The differential gauge for inlet air pressure displays the difference in the pressure that is measured before the air cleaner element and the pressure that is measured after the air cleaner element. As the air cleaner element becomes dirty, the pressure differential rises. If your engine is equipped with a different type of service indicator, follow the OEM recommendations to service the air cleaner service indicator.

Type 1 Service Indicator

The service indicator may be mounted on the air cleaner element or in a remote location.

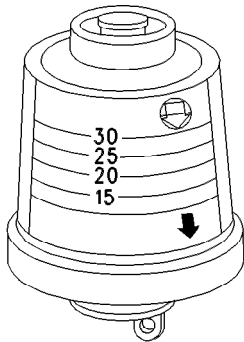

Illustration 110

g00103777

Typical example of type 1 service indicator

Observe the service indicator. The air cleaner element should be cleaned or the air cleaner element should be replaced when one of the following conditions occurs:

- The yellow diaphragm enters the red zone.

- The red piston locks in the visible position.

Type 2 Service Indicator

The service indicator is installed on the air cleaner element. The service indicator is to be tightened by hand, ensuring the o ring seal is in place.

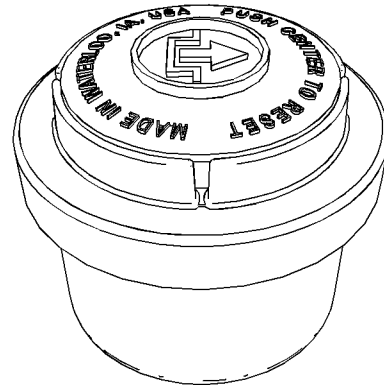

Illustration 111

g07079288

Typical example of type 2 service indicator

Observe the service indicator. The air cleaner element should be cleaned or the air cleaner element should be replaced when one of the following conditions occurs:

- The yellow diaphragm enters the red zone.
- The red piston locks in the visible position.

Test the Service Indicator

Service indicators are important instruments.

- Check for ease of resetting. The service indicator should reset in fewer than three pushes.
- Check the movement of the yellow core when the engine is accelerated to the engine rated speed. The yellow core should latch at the greatest vacuum that is attained.

If the service indicator does not reset easily, or if the yellow core does not latch at the greatest vacuum, the service indicator should be replaced. If the new service indicator will not reset, the hole for the service indicator may be restricted.

The service indicator may need to be replaced frequently in environments that are severely dusty.

i10077461

Engine Air Precleaner - Check/Clean

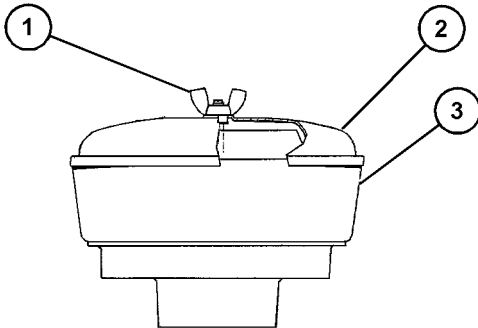

Illustration 112

g07723720

Typical engine air pre-cleaner

- (1) Wing nut
- (2) Cover
- (3) Body

Remove wing nut (1) and cover (2). Check for an accumulation of dirt and debris in body (3). Clean the body, if necessary.

After cleaning the pre-cleaner, install cover (2) and wing nut (1).

Note: When the engine is operated in dusty conditions, more frequent cleaning is required.

Do not tap or strike the air cleaner element.

i07819538

Engine Mounts - Inspect

Note: The engine mounts may not have been supplied by Perkins. Refer to the Original Equipment Manufacturer (OEM) information for further details on the engine mounts and the correct bolt torque.

Inspect the engine mounts for deterioration and for correct bolt torque. Excessive engine vibration can be caused by the following conditions:

- Incorrect mounting of the engine
- Deterioration of the engine mounts
- Loose engine mounts

Any engine mount that shows deterioration should be replaced. Refer to the OEM information for the recommended torques.

When the engine mounts are supplied by Perkins the maintenance procedure will be supplied in the Disassembly and Assembly manual for your engine.

i08055063

Engine Oil Level - Check

WARNING

Hot oil and hot components can cause personal injury. Do not allow hot oil or hot components to contact the skin.

NOTICE

Perform this maintenance with the engine stopped.

Note: Ensure that the engine is either level or that the engine is in the normal operating position to obtain a true level indication.

NOTICE

Do not overfill the crankcase. Engine damage can result.

Before Operating the Engine

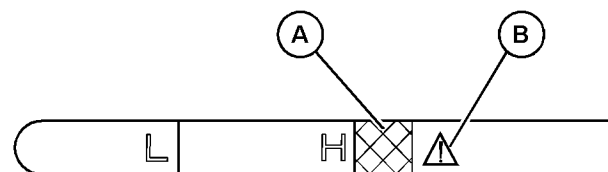

Illustration 113

g06525971

Typical example of type 2 oil level gauge (dipstick)

- (L) Low
- (H) High
- (A) Crosshatched area
- (B) Warning symbol



Illustration 114

g06551003

Typical example of type 1 oil level gauge (dipstick)

(L) Low
(H) High

1. Maintain the oil level between the mark (L) and the mark (H) on the engine oil level gauge (dipstick). Do not fill the crankcase above the (H).

NOTICE

The oil level checked that falls in the crosshatched (Position "A") area between the (H) and below the warning triangle (Position "B") is safe for engine operation.

Operating your engine when the oil level is in the warning triangle area (Position "B") above crosshatched section (Position "A") could cause your crankshaft to dip into the oil. The air bubbles created from the crankshaft dipping into the oil reduces the oils lubricating characteristics and could result in the loss of power.

2. Remove the oil filler cap and add oil, if necessary.
3. Clean the oil filler cap. Install the oil filler cap.
4. If necessary, drain a small quantity of oil from the crankcase to reduce the oil level. The oil level needs to be between the mark (L) and the mark (H) before operating the engine. Refer to the "Operation and Maintenance Manual", Engine Oil and Filter – Change, "Drain the Engine Lubricating Oil" for more information.

After Operating the Engine

Note: Before checking the oil level, the engine must have been switched off for a minimum of 30 minutes to allow the oil to drain down to the crankcase.

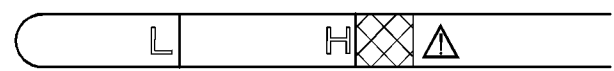

Illustration 115

g06553532

Typical example of type 2 oil level gauge (dipstick)

(L) Low
(H) High



Illustration 116

g06551003

Typical example of type 1 oil level gauge (dipstick)

(L) Low
(H) High

1. Check the oil level and maintain the oil level between the mark (L) and the mark (H) on the engine oil level gauge (dipstick). Do not fill the crankcase above the mark (H).
2. If necessary, remove the oil filler cap and add oil.

Note: When the oil level is shown to be at the (L) mark, 1 L (0.3 US gal) of oil added will bring up the oil level within the (L) and (H) marks.

3. Clean the oil filler cap and install the oil filler cap.

If an increase in the oil level is noticed, refer to Troubleshooting, "Oil Contains Fuel".

i01907674

Engine Oil Sample - Obtain

The condition of the engine lubricating oil may be checked at regular intervals as part of a preventive maintenance program. Perkins include an oil sampling valve as an option. The oil sampling valve (if equipped) is included in order to regularly sample the engine lubricating oil. The oil sampling valve is positioned on the oil filter head or the oil sampling valve is positioned on the cylinder block.

Perkins recommends using a sampling valve in order to obtain oil samples. The quality and the consistency of the samples are better when a sampling valve is used. The location of the sampling valve allows oil that is flowing under pressure to be obtained during normal engine operation.

Obtain the Sample and the Analysis

WARNING

Hot oil and hot components can cause personal injury. Do not allow hot oil or hot components to contact the skin.

In order to help obtain the most accurate analysis, record the following information before an oil sample is taken:

- The date of the sample
- Engine model
- Engine number
- Service hours on the engine
- The number of hours that have accumulated since the last oil change
- The amount of oil that has been added since the last oil change

Ensure that the container for the sample is clean and dry. Also ensure that the container for the sample is clearly labelled.

To ensure that the sample is representative of the oil in the crankcase, obtain a warm, well mixed oil sample.

To avoid contamination of the oil samples, the tools and the supplies that are used for obtaining oil samples must be clean.

The sample can be checked for the following: the quality of the oil, the existence of any coolant in the oil, the existence of any ferrous metal particles in the oil and the existence of any nonferrous metal particles in the oil.

i08154951

Engine Oil and Filter - Change

WARNING

Hot oil and hot components can cause personal injury. Do not allow hot oil or hot components to contact the skin.

NOTICE

Care must be taken to ensure that fluids are contained during performance of inspection, maintenance, testing, adjusting and repair of the product. Be prepared to collect the fluid with suitable containers before opening any compartment or disassembling any component containing fluids.

Dispose of all fluids according to local regulations and mandates.

NOTICE

Keep all parts clean from contaminants.

Contaminants may cause rapid wear and shortened component life.

Do not drain the engine lubricating oil when the engine is cold. As the engine lubricating oil cools, suspended waste particles settle on the bottom of the oil pan. The waste particles are not removed with draining cold oil. Allow 30 minutes after the engine is stopped, before draining the oil pan. Drain the oil pan with the oil warm. This draining method allows the waste particles that are suspended in the oil to be drained properly.

Failure to follow this recommended procedure will cause the waste particles to be recirculated through the engine lubrication system with the new oil.

Oil and Filter Change Intervals

The standard engine oil and filter change period is 500 hours or 1 year, whichever occurs sooner. There are several other factors that can alter the standard engine oil and filter change of 500 hours.

- If the engine is using engine oil analysis to determine oil and filter change period.
- The engine is working in a severe service environment/Load Factor

- Infrequent operation of the engine

Refer to this Operation and Maintenance Manual, "Severe Service Application" for more information on reducing the engine oil and filter change period. For severe service applications the recommended oil and filter change period is 250 hours.

If the engine is operated in severe service conditions, Perkins recommends the use of engine oil sampling. Refer to this Operation and Maintenance Manual, Engine Oil sample - Obtain for more information.

If the engine is operated infrequently less than 500 hours in a 12-month period, then the engine oil and filter change should be conducted yearly.

Draining the Engine Lubricating Oil From a Standard Oil Pan

Note: Ensure that the vessel that will be used is large enough to collect the waste oil.

After the engine has been run at the normal operating temperature, stop the engine. Use the following method to drain the engine oil pan:

4. Tighten oil drain plug (1) to a torque of 24 N·m (212 lb in). Remove the container below oil drain plug (1) and discard waste oil in accordance with local regulations.

Note: A drain valve may be installed. Tighten the drain valve to a torque of 24 N·m (212 lb in).

Draining the Engine Lubricating Oil From an Oil Pan Equipped With a Balancer

Note: Ensure that the vessel that will be used is large enough to collect the waste oil.

After the engine has been run at the normal operating temperature, stop the engine. Use the following method to drain the engine oil pan:

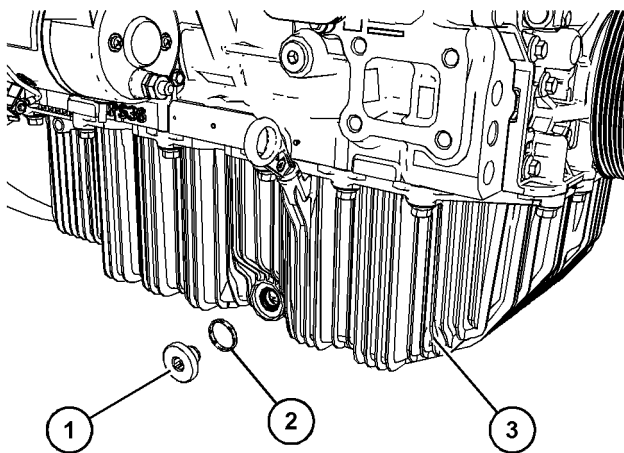

Illustration 117

g06512019

Typical example of a nonmetallic oil pan.

1. Place container below oil drain plug (1). Remove the oil drain plug and allow the oil to drain into the container for storage or disposal.
2. Remove drain plug seal (2) from the drain plug. Discard the drain plug seal.
3. Clean oil drain plug (1) and install new drain plug seal (2). Install oil drain plug (1) into oil pan (3).

Maintenance Section
Engine Oil and Filter - Change

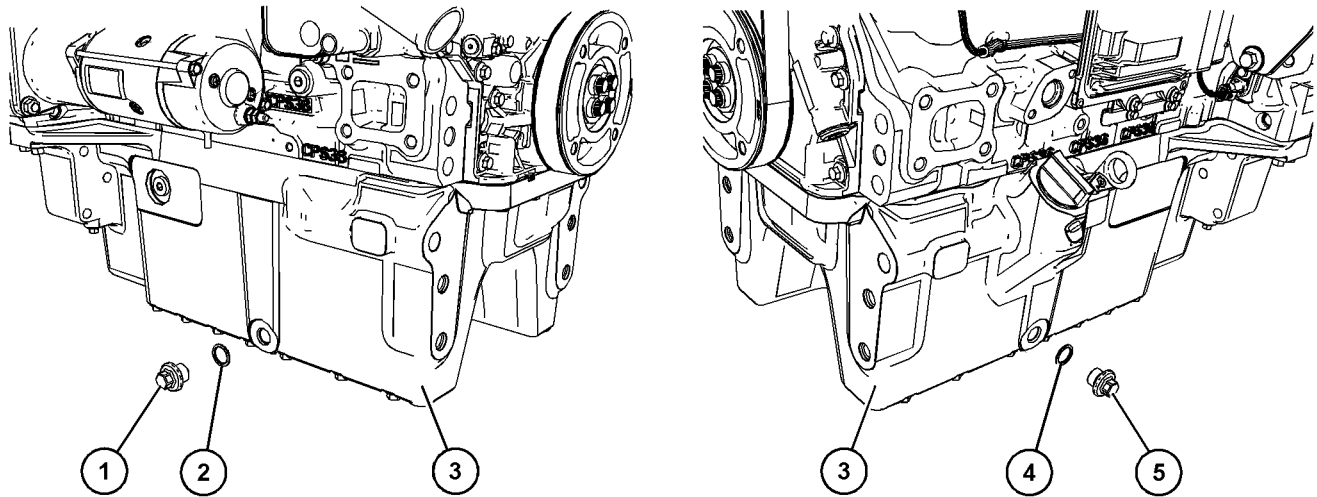

Illustration 118

g06511911

Typical example of an engine oil pan with a balancer

1. Place a suitable container below oil drain plug (1) and oil drain plug (5).
2. Remove oil drain plug (1) and oil drain plug (5) from engine oil pan (3) and allow the oil to drain into the container for storage or disposal.
3. Remove drain plug seal (2) and drain plug seal (4). Discard the seals.
4. Clean the oil drain plugs and install new drain plug seal (2) and new drain plug seal (4). Install oil drain plug (1) and oil drain plug (5) into oil pan (3).

5. Tighten oil drain plug (1) and oil drain plug (5) to a torque of 24 N·m (212 lb in). Remove container below oil drain plug (1) and oil drain plug (5). Discard waste oil in accordance with local regulations.

Replace the Oil Filter Element

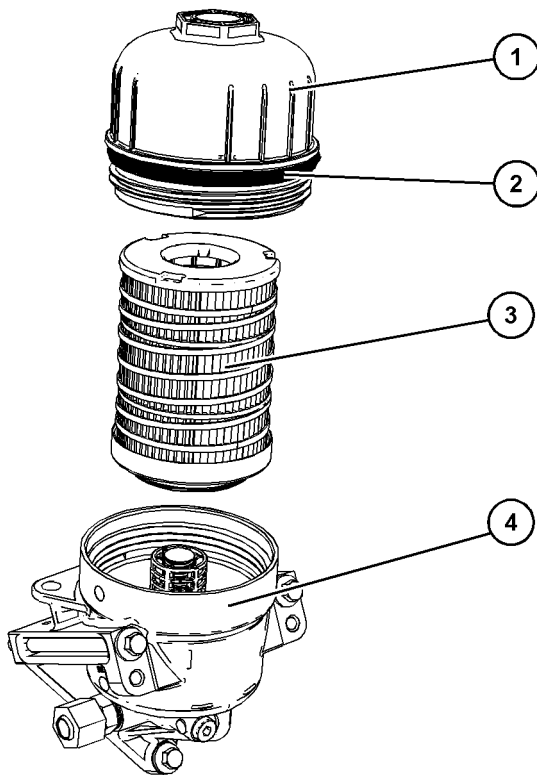

Illustration 119

g06304150

Typical example

1. Remove cap (1) from filter body (4). The filter element (3) will be attached to cap (1). Remove filter element (3) from cap (1). Discard old filter element.
2. Remove O ring seal (2) from cap (1). Discard O ring seal.
3. Ensure that cap and filter body are clean and free from dirt or damage. Inspect new filter element for damage before installing.
4. Install new O ring seal (2) onto cap (1). Install new filter element (3) into cap (1). Install new filter element (3) and cap (1) to filter body (4).

5. Tighten cap (1) to a torque of 24 N·m (212 lb in)

Fill the Oil Pan

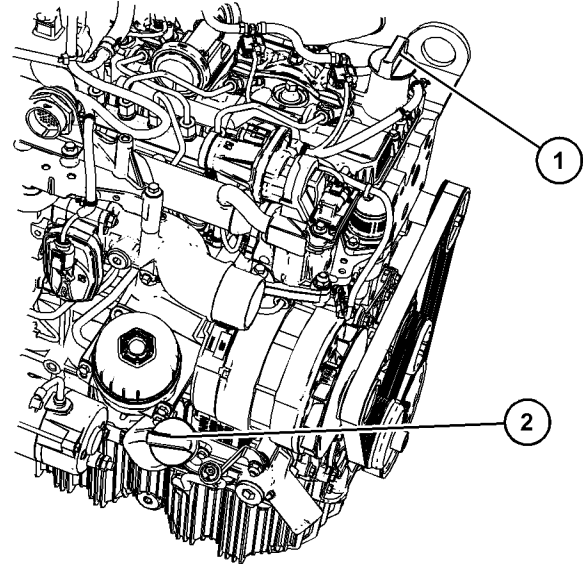

Illustration 120

g06304141

Typical example

- (1) Top mounted filler cap
- (2) Side-mounted filler cap

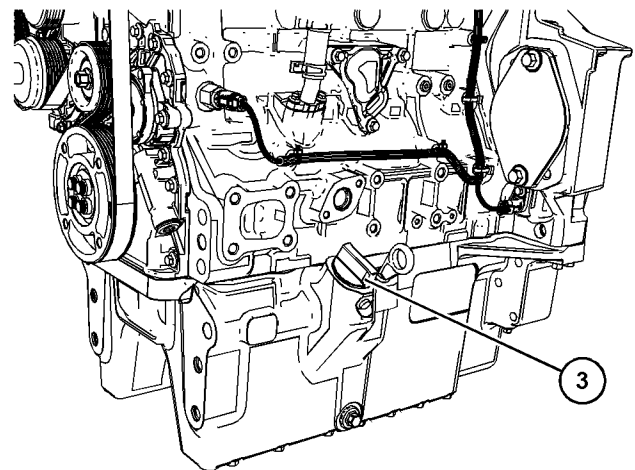

Illustration 121

g06512039

Typical example of engines equipped with a balancer

- (3) Oil pan-mounted filler

1. Refer to this Operation and Maintenance Manual, "Fluid Recommendations" for more information on suitable oils.

- Fill the oil pan with the correct amount of new engine lubricating oil. Refer to this Operation and Maintenance Manual, "Refill Capacities" for more information on refill capacities.

Note: If the oil is filled through the top mounted filler cap (1), allow the oil to drain down to the oil pan for a minimum of 30 minutes before starting the engine.

- After installing the oil filler cap, start the engine and run the engine at "LOW IDLE" for 2 minutes. Perform this procedure to ensure that the lubrication system has oil and that the oil filter is filled. Inspect the oil filter for oil leaks.
- Stop the engine and allow the oil to drain back to the oil pan for a minimum of 30 minutes.
- Remove the engine oil level gauge to check the oil level. Maintain the oil level between "L" and "H" marks on the engine oil level gauge. Do not fill the crankcase above the "H" mark.

Note: For more information on accurate oil level check, refer to this Operation and Maintenance Manual, "Engine Oil Level - Check".

i09953651

Fan Clearance - Check

Ensure that the engine is stopped. Ensure that the battery disconnect switch is in the OFF position. Ensure that the cooling system is full.

904J-E36TA Industrial Open Power Unit (IOPU)

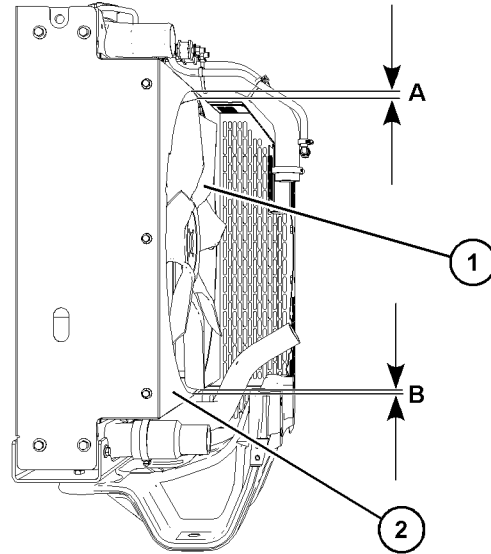

Illustration 122

g06739966

Typical example

The clearance between the cover (2) and the fan (1) will require checking. The gap between the edge of the cover and the tip of the fan blade must be checked at positions (A) and (B).

- (A) equals 6.5 mm (0.25590 inch)

- (B) equals 5.5 mm (0.21654 inch)

904J-E28T Industrial Open Power Unit (IOPU)

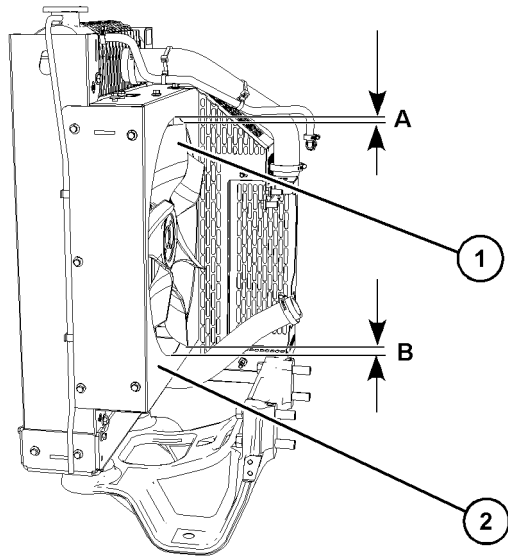

Illustration 123

g06740057

Typical example

The clearance between the cover (2) and the fan (1) will require checking. The gap between the edge of the cover and the tip of the fan blade must be checked at positions (A) and (B).

- (A) equals 10.5 mm (0.41339 inch)
- (B) equals 9.5 mm (0.37402 inch)

i07669646

Fuel System - Prime

Note: Refer to **Systems Operation, Testing, and Adjusting, “Cleanliness of Fuel System Components”** for detailed information on the standards of cleanliness that must be observed during ALL work on the fuel system.

Ensure that all adjustments and repairs are performed by authorized personnel that have had the correct training.

NOTICE

Do not crank the engine continuously for more than 30 seconds. Allow the starting motor to cool for two minutes before cranking the engine again.

If air enters the fuel system, the air must be purged from the fuel system before the engine can be started. Air can enter the fuel system when the following events occur:

- The fuel tank is empty or the fuel tank has been partially drained.
- The low-pressure fuel lines are disconnected.
- A leak exists in the low-pressure fuel system.
- The fuel filter has been replaced.

Electric Fuel Priming Pump

Use the following procedure to remove air from the fuel system:

1. Ensure that the fuel system is in working order. Check that the fuel supply valve (if equipped) is in the “ON” position.
2. Turn the keyswitch to the “RUN” position.
3. The keyswitch will allow the electric priming pump to operate. Operate the electric priming pump. The ECM will stop the pump after 2 minutes.
4. Turn the keyswitch to the “OFF” position. The fuel system should now be primed and the engine should be able to start.
5. Operate the engine starter and crank the engine. After the engine has started, operate the engine at low idle for a minimum of 5 minutes. Ensure that the fuel system is free from leaks.

Note: Operating the engine for this period will help ensure that the fuel system is free of air. **DO NOT loosen the high-pressure fuel lines to purge air from the fuel system. This procedure is not required.**

After the engine has stopped, you must wait for 10 minutes to allow the fuel pressure to be purged from the high-pressure fuel lines before any service or repair is performed on the engine fuel lines. The 10 minute wait will also allow static charge to dissipate from the low-pressure fuel system. If necessary, perform minor adjustments. Repair any leaks from the low-pressure fuel system and from the cooling, lubrication, or air systems. Replace any high-pressure fuel line that has leaked. Refer to Disassembly and Assembly Manual, “Fuel Injection Lines - Install”.

If you inspect the engine in operation, always use the proper inspection procedure to avoid a fluid penetration hazard. Refer to Operation and Maintenance Manual, “General hazard Information”.

If the engine will not start, refer to Troubleshooting, "Engine Cranks but will not Start".

Mechanical Fuel Priming Pump

Use the following procedure to remove air from the fuel system:

1. Ensure that the fuel system is in working order. Check that the fuel supply valve (if equipped) is in the "ON" position.
2. Operate the hand priming pump. Count the number of operations of the pump. After approximately 80 depression of the pump stop.

Note: As the fuel system is primed, the pressure will increase within the fuel system and this increase in pressure can be felt during priming.

3. The fuel system should now be primed and the engine should be able to start.
4. Operate the engine starting motor and crank the engine. After the engine has started, operate the engine at low idle for a minimum of 5 minutes. Ensure that the fuel system is free from leaks.

Note: Operating the engine for this period will help ensure that the fuel system is free of air. **DO NOT loosen the high-pressure fuel lines to purge air from the fuel system. This procedure is not required.**

After the engine has stopped, you must wait for 10 minutes to allow the fuel pressure to be purged from the high-pressure fuel lines before any service or repair is performed on the engine fuel lines. The 10 minute wait will also allow static charge to dissipate from the low-pressure fuel system. If necessary, perform minor adjustments. Repair any leaks from the low-pressure fuel system and from the cooling, lubrication, or air systems. Replace any high-pressure fuel line that has leaked. Refer to Disassembly and Assembly Manual, "Fuel Injection Lines - Install".

If you inspect the engine in operation, always use the proper inspection procedure to avoid a fluid penetration hazard. Refer to Operation and Maintenance Manual, "General hazard Information".

If the engine will not start, refer to Troubleshooting, "Engine Cranks but will not Start".

i07385499

Fuel System Primary Filter (Water Separator) Element - Replace

WARNING

Fuel leaked or spilled onto hot surfaces or electrical components can cause a fire. To help prevent possible injury, turn the start switch off when changing fuel filters or water separator elements. Clean up fuel spills immediately.

Note: Refer to Systems Operation, Testing, and Adjusting, "Cleanliness of Fuel System Components" for detailed information on the standards of cleanliness that must be observed during ALL work on the fuel system.

NOTICE

Ensure that the engine is stopped before any servicing or repair is performed.

Fuel System Primary Filter (Water Separator) Element for Electric Fuel Priming Pump

Remove the Element

1. Turn the fuel supply valve (if equipped) to the OFF position before performing this maintenance.
2. Place a suitable container under the water separator to catch any fuel that might spill. Clean up any spilled fuel. Clean the outside body of the filter assembly.

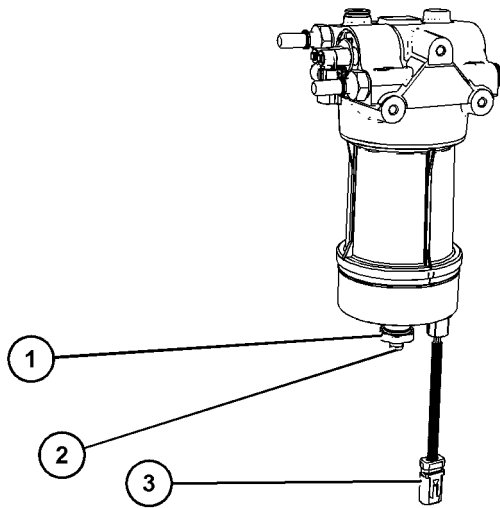

Illustration 124

g06304505

Typical example

3. Install a suitable tube onto drain (2). Open the drain valve (1). Rotate the drain valve fully counterclockwise. Two full turns are required.
4. Allow the fuel to drain into the container.
5. Remove the tube from the drain (2).
6. Remove the wiring harness from connection (3).
7. Rotate filter bowl (5) counterclockwise and remove the filter bowl from assembly.

Note: If a strap wrench is required to loosen the filter bowl (5), ensure that the strap is positioned in the middle of the ribbed section. To avoid damage or mechanical failure, do not position the strap around the clear area. Do not apply loads to the clear plastic bowl and the joint of the black plastic section of the lower bowl.

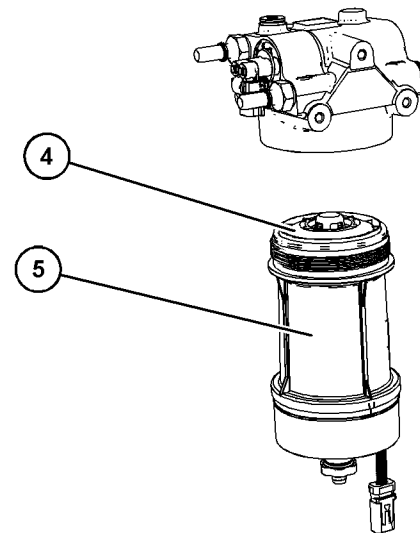

Illustration 125

g06304508

Typical example

8. Remove the filter element (4). Clean the filter bowl.

Install the New Filter Element

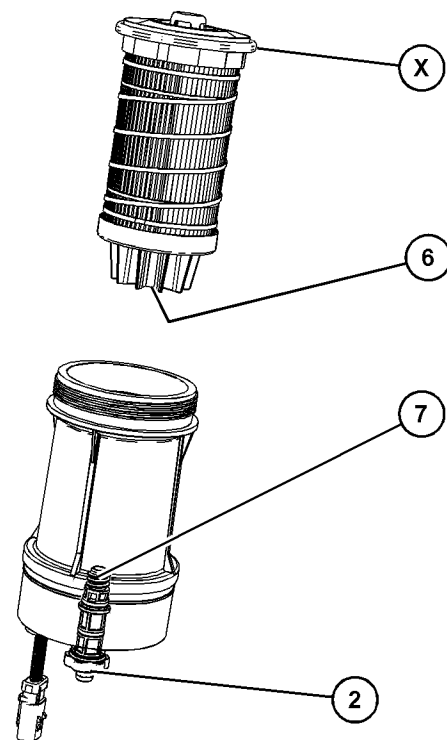

Illustration 126

g06304524

Typical example

Maintenance Section

Fuel System Primary Filter (Water Separator) Element - Replace

1. After repositioning the self-venting drain up, locate the thread in the new filter element (6) onto the thread (7). Spin on the filter element and tighten the drain valve (2) securely.
2. Lubricate the lip (Position (X)) with clean engine oil. Do NOT fill the bowl with fuel before the assembly is installed.

Note: Do not use a tool to install the filter assembly.

3. Align the filter bowl (5) to the assembly. Rotate the filter bowl (5) clockwise by hand. Rotate the filter bowl (5) until there is no visible gap between the element and the filter bowl and the assembly.
4. Remove the container and dispose of the fuel in a safe place.
5. Install the wiring harness to connection (3).
6. The secondary filter element (if equipped) must be replaced at the same time as the primary filter element. Refer to the Operation and Maintenance Manual, "Fuel System Secondary Filter - Replace".

Fuel System Primary Filter (Water Separator) Element for Manual Fuel Priming Pump

Remove the Element

1. Turn the fuel supply valve (if equipped) to the OFF position before performing this maintenance.
2. Place a suitable container under the water separator to catch any fuel that might spill. Clean up any spilled fuel. Clean the outside body of the filter assembly.

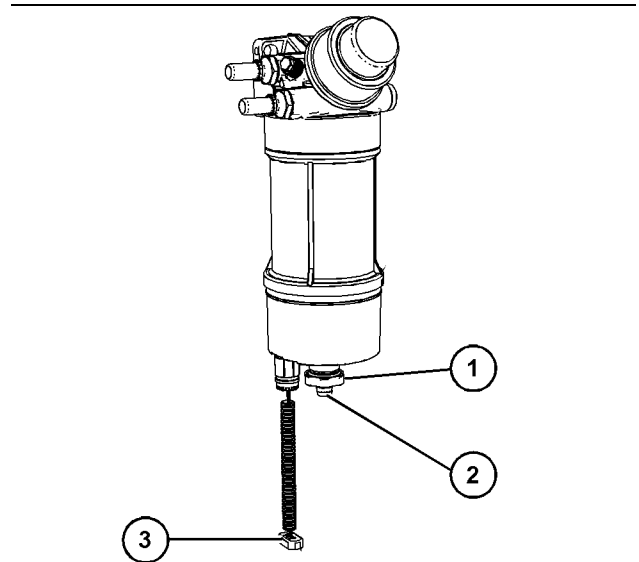

Illustration 127

g06398147

Typical example

3. Install a suitable tube onto drain (2). Open the drain valve (1). Rotate the drain valve fully counterclockwise. Two full turns are required.
4. Allow the fuel to drain into the container.
5. Remove the tube from the drain (2).
6. Remove the wiring harness from connection (3).
7. Rotate filter bowl (5) counterclockwise and remove the filter bowl from assembly.

Note: If a strap wrench is required to loosen the filter bowl (5), ensure that the strap is positioned in the middle of the ribbed section. To avoid damage or mechanical failure, do not position the strap around the clear area. Do not apply loads to the clear plastic bowl and the joint of the black plastic section of the lower bowl.

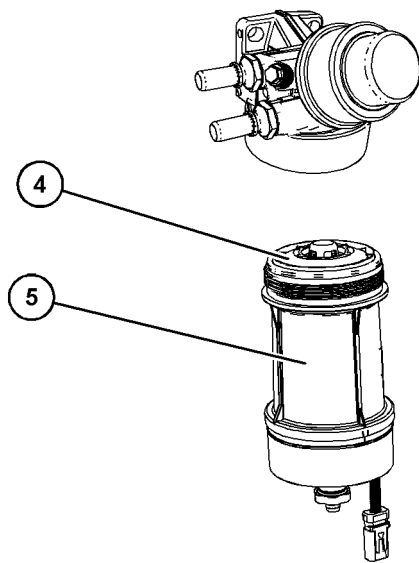

Illustration 128

g06398170

Typical example

8. Remove the filter element (4). Clean the filter bowl.

Install the New Filter Element

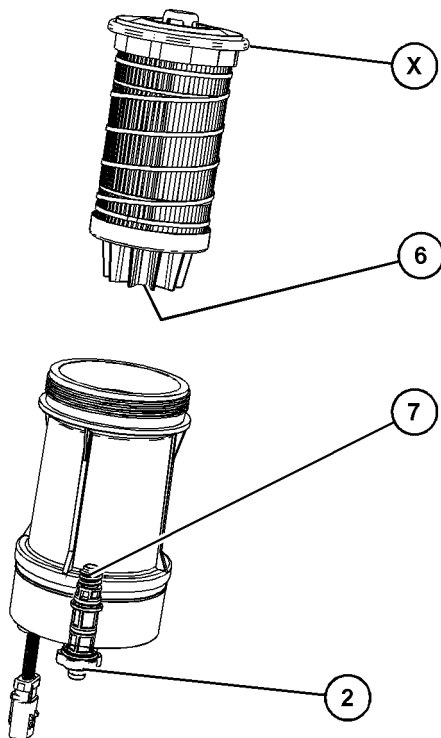

Illustration 129

g06304524

Typical example

1. After repositioning the self-venting drain up, locate the thread in the new filter element (6) onto the thread (7). Spin on the filter element and tighten the drain valve (2) securely.

2. Lubricate the lip (Position (X)) with clean engine oil. Do NOT fill the bowl with fuel before the assembly is installed.

Note: Do not use a tool to install the filter assembly.

3. Align the filter bowl (5) to the assembly. Rotate the filter bowl (5) clockwise by hand. Rotate the filter bowl (5) until there is no visible gap between the element and the filter bowl and the assembly.

4. Remove the container and dispose of the fuel in a safe place.

5. Install the wiring harness to connection (3).

6. The secondary filter element (if equipped) must be replaced at the same time as the primary filter element. Refer to the Operation and Maintenance Manual, "Fuel System Secondary Filter - Replace".

i07385529

Fuel System Primary Filter/ Water Separator - Drain

⚠ WARNING

Fuel leaked or spilled onto hot surfaces or electrical components can cause a fire. To help prevent possible injury, turn the start switch off when changing fuel filters or water separator elements. Clean up fuel spills immediately.

NOTICE

Ensure that the engine is stopped before any servicing or repair is performed.

NOTICE

The water separator is under suction during normal engine operation. Ensure that the drain valve is tightened securely to help prevent air from entering the fuel system.

Drain Procedure

1. Place a suitable container under the water separator to catch any fluid that might spill. Clean up any spilled fluid.

Maintenance Section
Fuel System Secondary Filter - Replace

2. Ensure that the outer body of the filter assembly is clean and free from dirt.

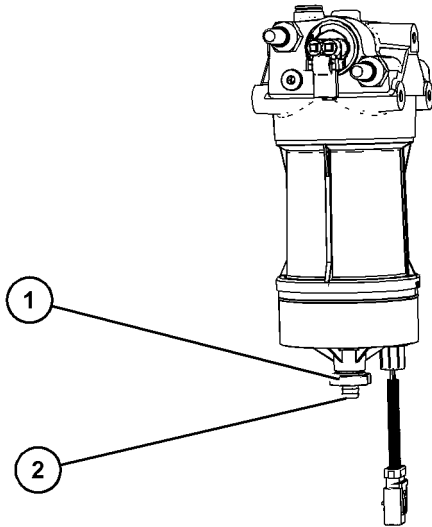

Illustration 130

g06304526

Typical example

3. Install a suitable tube onto drain (2). Open the drain valve (1). Rotate the drain valve fully counterclockwise. Two full turns are required.
4. Visually check that the fluid will drain. Allow the fluid to drain into the container.
5. When fluid free from water comes from the primary fuel filter, tighten the drain valve clockwise by hand only. Remove the tube and remove the container.

i07694301

Fuel System Secondary Filter - Replace

⚠ WARNING

Fuel leaked or spilled onto hot surfaces or electrical components can cause a fire. To help prevent possible injury, turn the start switch off when changing fuel filters or water separator elements. Clean up fuel spills immediately.

NOTICE

Ensure that the engine is stopped before any servicing or repair is performed.

Refer to **Systems Operation, Testing, and Adjusting, "Cleanliness of Fuel System Components"** for detailed information on the standards of cleanliness that must be observed during ALL work on the fuel system.

Remove the Element

1. Turn the fuel supply valve (if equipped) to the OFF position before performing this maintenance.
2. Place a suitable container under the fuel filter to catch any fuel that might spill. Clean up any spilled fuel. Clean the outside body of the filter assembly.

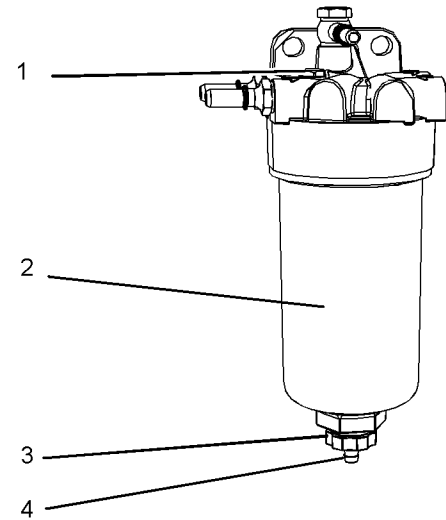

Illustration 131

g03088718

3. Install a suitable tube onto drain (4). Open the drain valve (3). Rotate the drain valve counterclockwise. Two full turns are required. Loosen vent screw (1).
4. Allow the fuel to drain into the container and remove the tube.
5. Tighten the vent screw (1) to a torque of 2.5 N·m (22 lb in).
6. Remove the filter bowl (2). Rotate the filter assembly counterclockwise to remove the assembly.

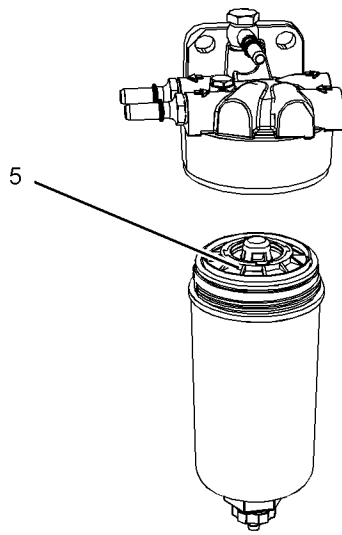

Illustration 132

g02546456

7. Rotate the filter element (5) counterclockwise and remove the filter element. Clean the filter bowl.

Install the Element

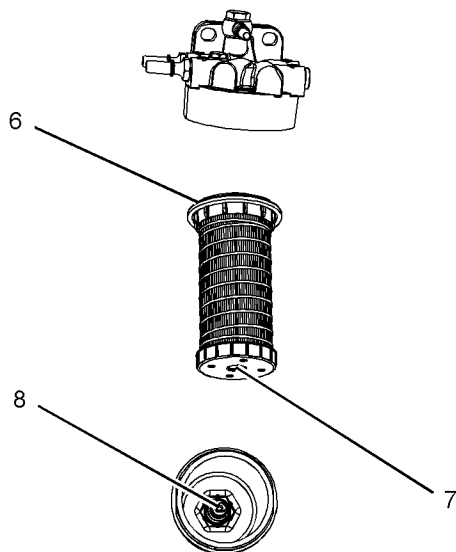

Illustration 133

g03088837

1. Locate the thread (7) in the filter element onto the threads (8). Spin on the element and tighten the drain valve (3) by hand.
2. Lubricate the O ring seal (6) with clean engine oil. Do NOT fill the filter bowl (2) with fuel before the filter assembly is installed.

3. Do not use a tool to install the filter assembly. Tighten the assembly by hand. Install the filter bowl (2). Turn the filter bowl clockwise until the filter bowl locks into position against the stops.
4. Turn the fuel supply valve to the ON position.
5. The primary and secondary fuel filters must be replaced at the same time. Refer to the Operation and Maintenance Manual, "Fuel System Primary Filter (Water Separator) Element - Replace".
6. Prime the fuel system. Refer to the Operation and Maintenance Manual, "Fuel System - Prime" for more information.

i02348492

Fuel Tank Water and Sediment - Drain

NOTICE

Care must be taken to ensure that fluids are contained during performance of inspection, maintenance, testing, adjusting and repair of the product. Be prepared to collect the fluid with suitable containers before opening any compartment or disassembling any component containing fluids.

Dispose of all fluids according to local regulations and mandates.

Fuel Tank

Fuel quality is critical to the performance and to the service life of the engine. Water in the fuel can cause excessive wear to the fuel system.

Water can be introduced into the fuel tank when the fuel tank is being filled.

Condensation occurs during the heating and cooling of fuel. The condensation occurs as the fuel passes through the fuel system and the fuel returns to the fuel tank. This causes water to accumulate in fuel tanks. Draining the fuel tank regularly and obtaining fuel from reliable sources can help to eliminate water in the fuel.

Drain the Water and the Sediment

Fuel tanks should contain some provision for draining water and draining sediment from the bottom of the fuel tanks.

Open the drain valve on the bottom of the fuel tank in order to drain the water and the sediment. Close the drain valve.

Check the fuel daily. Allow five minutes after the fuel tank has been filled before draining water and sediment from the fuel tank.

Fill the fuel tank after operating the engine in order to drive out moist air. This will help prevent condensation. Do not fill the tank to the top. The fuel expands as the fuel gets warm. The tank may overflow.

Some fuel tanks use supply pipes that allow water and sediment to settle below the end of the fuel supply pipe. Some fuel tanks use supply lines that take fuel directly from the bottom of the tank. If the engine is equipped with this system, regular maintenance of the fuel system filter is important.

Fuel Storage Tanks

Drain the water and the sediment from the fuel storage tank at the following intervals:

- Weekly
- Service intervals
- Refill of the tank

This will help prevent water or sediment from being pumped from the storage tank into the engine fuel tank.

If a bulk storage tank has been refilled or moved recently, allow adequate time for the sediment to settle before filling the engine fuel tank. Internal baffles in the bulk storage tank will also help trap sediment. Filtering fuel that is pumped from the storage tank helps to ensure the quality of the fuel. When possible, water separators should be used.

i07819616

Hoses and Clamps - Inspect/Replace

WARNING

Contact with high pressure fuel may cause fluid penetration and burn hazards. High pressure fuel spray may cause a fire hazard. Failure to follow these inspection, maintenance and service instructions may cause personal injury or death.

If you inspect the engine in operation, always use the proper inspection procedure to avoid a fluid penetration hazard. Refer to Operation and Maintenance Manual, "General hazard Information" and Operation and Maintenance Manual, "High Pressure Fuel Lines" for the correct procedures.

Inspect all hoses for leaks that are caused by the following conditions:

- Cracking
- Softness
- Loose clamps

Replace hoses that are cracked or soft. Tighten any loose clamps.

Check for the following conditions:

- End fittings that are damaged or leaking
- Outer covering that is chafed or cut
- Exposed wire that is used for reinforcement
- Outer covering that is ballooning locally
- Flexible part of the hose that is kinked or crushed
- Armoring that is embedded in the outer covering

A constant torque hose clamp can be used in place of any standard hose clamp. Ensure that the constant torque hose clamp is the same size as the standard clamp.

Due to extreme temperature changes, the hose will harden. Hardening of the hoses will cause hose clamps to loosen. This can result in leaks. A constant torque hose clamp will help to prevent loose hose clamps.

Each installation application can be different. The differences depend on the following factors:

- Type of hose
- Type of fitting material
- Anticipated expansion and contraction of the hose
- Anticipated expansion and contraction of the fittings

Replace the Hoses and the Clamps

Refer to the OEM information for further information on removing and replacing fuel hoses (if equipped).

The following text describes a typical method of replacing coolant hoses. Refer to the OEM information for further information on the coolant system and the hoses for the coolant system.

WARNING

Pressurized System: Hot coolant can cause serious burns. To open the cooling system filler cap, stop the engine and wait until the cooling system components are cool. Loosen the cooling system pressure cap slowly in order to relieve the pressure.

1. Stop the engine. Allow the engine to cool.
2. Loosen the cooling system filler cap slowly to relieve any pressure. Remove the cooling system filler cap.

Note: Drain the coolant into a suitable, clean container. The coolant can be reused.

3. Drain the coolant from the cooling system to a level that is below the hose that is being replaced.
4. Remove the hose clamps.
5. Disconnect the old hose.
6. Replace the old hose with a new hose.
7. Install the hose clamps with a torque wrench.

Note: For the correct coolant, see this Operation and Maintenance Manual, "Fluid Recommendations".

8. Refill the cooling system. Refer to the OEM information for further information on refilling the cooling system.
9. Clean the cooling system filler cap. Inspect the cooling system filler cap's seals. Replace the cooling system filler cap if the seals are damaged. Install the cooling system filler cap.
10. Start the engine. Inspect the cooling system for leaks.

i09666139

Radiator - Clean

The radiator is not usually supplied by Perkins. The following text describes a typical cleaning procedure for the radiator. Refer to the OEM documents for further information on cleaning the radiator.

Note: Adjust the frequency of cleaning according to the effects of the operating environment.

Inspect the radiator for these items: Damaged fins, corrosion, dirt, grease, insects, leaves, oil, and other debris. Clean the radiator if necessary.

WARNING

Personal injury can result from air pressure.

Personal injury can result without following proper procedure. When using pressure air, wear a protective face shield and protective clothing.

Maximum air pressure at the nozzle must be less than 205 kPa (30 psi) for cleaning purposes.

Pressurized air is the preferred method for removing loose debris. Direct the air in the opposite direction to the air flow of the fan. Hold the nozzle approximately 6 mm (0.25 inch) away from the radiator fins. Slowly move the air nozzle in a direction that is parallel with the radiator tube assembly to remove debris that is between the tubes.

Pressurized water may also be used for cleaning. The maximum water pressure for cleaning purposes must be less than 275 kPa (40 psi). Use pressurized water to soften mud. Clean the core from the front and the rear.

Use a degreaser and steam for removal of oil and grease. Clean the front and the rear of the core. Wash the core with detergent and hot water. Thoroughly rinse the core with clean water.

If the radiator is blocked internally, refer to the OEM manual for information on flushing the cooling system.

After cleaning the radiator, start the engine. Allow the engine to operate at low idle speed for three to five minutes. Accelerate the engine to high idle to help in the removal of debris from the core and the drying of the core. Slowly reduce the engine speed to low idle and then stop the engine. Use a light bulb behind the core to inspect the core for cleanliness. Repeat the cleaning, if necessary.

Inspect the fins for damage. Bent fins may be opened with a "comb". Inspect these items for good condition: Welds, mounting brackets, air lines, connections, clamps, and seals. Make repairs, if necessary.

i08699338

Radiator Mounts - Inspect

There are 2 anti vibration mounts (AVM) (2) on the radiator support bracket (1). The anti vibration mounts require inspection at specific maintenance intervals.

i07888480

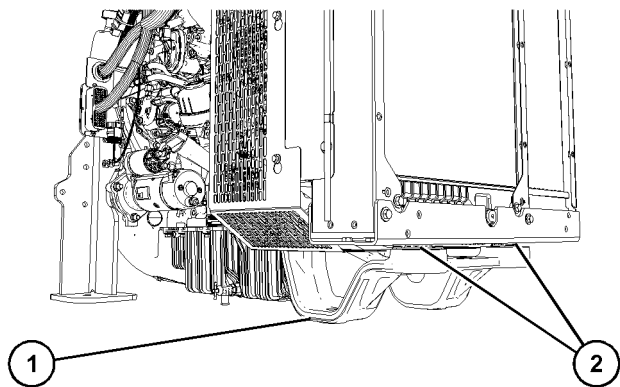

Illustration 134

g06745030

Typical example

- (1) Radiator support bracket
- (2) Radiator anti vibration mounts

i08187031

Starting Motor - Inspect

Perkins recommends a scheduled inspection of the starting motor. If the starting motor fails, the engine may not start in an emergency situation.

Check the starting motor for correct operation. Check the electrical connections and clean the electrical connections. Refer to the Systems Operation, Testing and Adjusting Manual, "Electric Starting System - Test" for more information on the checking procedure and for specifications consult your Perkins dealer or your Perkins distributor for assistance.

Turbocharger - Inspect

⚠ WARNING

Hot engine components can cause injury from burns. Before performing maintenance on the engine, allow the engine and the components to cool.

NOTICE

Turbocharger bearing failures can cause large quantities of oil to enter the air intake and exhaust systems. Loss of engine lubricant can result in serious engine damage.

Minor leakage of oil into a turbocharger under extended low idle operation should not cause problems as long as a turbocharger bearing failure has not occurred.

When a turbocharger bearing failure is accompanied by a significant engine performance loss (exhaust smoke or engine rpm up at no load), do not continue engine operation until the turbocharger is renewed.

A visual inspection of the turbocharger or turbochargers can minimize unscheduled downtime. A visual inspection of the turbocharger or turbochargers can also reduce the chance for potential damage to other engine parts. Do not inspect the engine with the engine in operation.

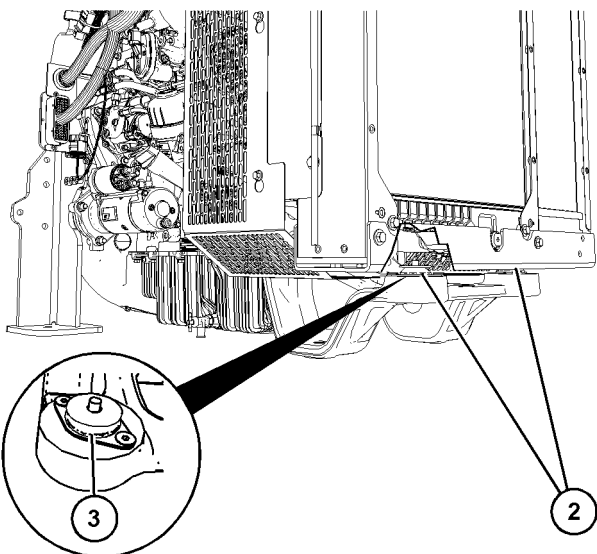

Illustration 135

g06745041

Typical example with a portion of the radiator cutaway for clarity

- (2) Radiator anti vibration mounts
- (3) Radiator anti vibration mounts rubber compound

The radiator may need to be lifted to inspect the 2 anti vibration mounts (AVM). Refer to Disassembly and Assembly, Radiator - Remove and Install.

Inspect the anti vibration mounts for wear, cracking, and damage. If the anti vibration mounts appear to be worn, cracked, or damaged replace the anti vibration mount. Refer to Disassembly and Assembly, Radiator Anti Vibration Mounts - Remove and Install.

i07385593

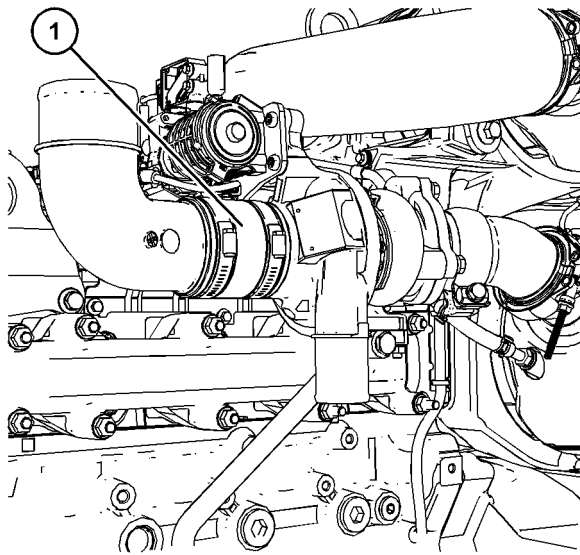

Illustration 136

g06304904

Typical example

1. Ensure that the turbocharger is clean and free from dirt before removing components for inspection.
2. Remove the pipe from the turbocharger exhaust outlet and remove the air intake pipe (1). Visually inspect the piping for the presence of oil. Clean the interior of the pipes to prevent dirt from entering during reassembly.
3. Check for obvious heat discoloration of the turbocharger. Check for any loose bolts or any missing bolts. Check for damage to the oil supply line and the oil drain line. Check for cracks in the housing of the turbocharger. Ensure that the compressor wheel can rotate freely.
4. Check for the presence of oil. If oil is leaking from the back side of the compressor wheel, there is a possibility of a failed turbocharger oil seal.

The presence of oil may be the result of extended engine operation at low idle. The presence of oil may also be the result of a restriction of the line for the intake air (clogged air filters), which causes the turbocharger to slobber.

5. Install the air intake pipe and the exhaust outlet pipe to the turbocharger housing. Ensure that all clamps are installed correctly and that all clamps are tightened securely. For more information, refer to Systems Operation, Testing, and Adjusting, "Turbocharger - Inspect".

Walk-Around Inspection

Inspect the Engine for Leaks and for Loose Connections

A walk-around inspection should only take a few minutes. When the time is taken to perform these checks, costly repairs and accidents can be avoided.

For maximum engine service life, make a thorough inspection of the engine compartment before starting the engine. Look for items such as oil leaks or coolant leaks, loose bolts, worn belts, loose connections, and trash buildup. Make repairs, as needed:

- The guards must be in the correct place. Repair damaged guards or replace missing guards.
- Wipe all caps and plugs before the engine is serviced to reduce the chance of system contamination.

NOTICE

For any type of leak (coolant, lube, or fuel) clean up the fluid. If leaking is observed, find the source and correct the leak. If leaking is suspected, check the fluid levels more often than recommended until the leak is found or fixed, or until the suspicion of a leak is proved to be unwarranted.

NOTICE

Accumulated grease and/or oil on an engine is a fire hazard. Remove the accumulated grease and oil. Refer to this Operation and Maintenance Manual, "Engine - Clean" for more information.

- Ensure that the cooling system hoses are correctly clamped and that the cooling system hoses are tight. Check for leaks. Check the condition of all pipes.
- Inspect the water pump for coolant leaks.

Excessive coolant leakage may indicate the need to replace the water pump. Remove the water pump. Refer to Disassembly and Assembly, "Water Pump - Remove and Install".

- Inspect the lubrication system for leaks at the front crankshaft seal, the rear crankshaft seal, the oil pan, the oil filters, and the rocker cover.
- Inspect the piping for the air intake system and the elbows for cracks and for loose clamps. Ensure that hoses and tubes are not contacting other hoses, tubes, wiring harnesses.

Maintenance Section
Water Pump - Inspect

- Ensure that the areas around the rotating parts are clear.
- Inspect the alternator belts and any accessory drive belts for cracks, breaks, or other damage.
- Inspect the wiring harness for damage.

Belts for multiple groove pulleys must be replaced as matched sets. If only one belt is replaced, the belt will carry more load than the belts that are not replaced. The older belts are stretched. The additional load on the new belt could cause the belt to break.

High-Pressure Fuel Lines

WARNING

Contact with high pressure fuel may cause fluid penetration and burn hazards. High pressure fuel spray may cause a fire hazard. Failure to follow these inspection, maintenance and service instructions may cause personal injury or death.

After the engine has stopped, wait 10 minutes to allow the fuel pressure to be purged from the high-pressure fuel lines before any service or repair is performed. The 10 minute wait will also allow static charge to dissipate from the low-pressure fuel system. If necessary, perform minor adjustments. Repair any leaks from the low-pressure fuel system and from the cooling, lubrication, or air systems. Replace any high-pressure fuel line that has leaked. Refer to Disassembly and Assembly Manual, "Fuel Injection Lines - Install".

If you inspect the engine in operation, always use the proper inspection procedure to avoid a fluid penetration hazard. Refer to Operation and Maintenance Manual, "General hazard Information".

Visually inspect the high-pressure fuel lines for damage or signs of fuel leakage. Replace any damaged high-pressure fuel lines or high-pressure fuel lines that have leaked.

Ensure that all clips on the high-pressure fuel lines are in place and that the clips are not loose.

- Inspect the rest of the fuel system for leaks. Look for loose fuel line clamps.
- Drain the water and the sediment from the fuel tank daily.
- Inspect the wiring and the wiring harnesses for loose connections and for worn wires or frayed wires. Check for any loose tie-wraps or missing tie-wraps.
- Inspect the ground strap for a good connection and for good condition.

- Disconnect any battery chargers that are not protected against the current drain of the starting motor. Check the condition and the electrolyte level of the batteries, unless the engine is equipped with a maintenance free battery.
- Check the condition of the gauges. Replace any gauges that are cracked. Replace any gauge that cannot be calibrated.

Engine Aftertreatment

Check the condition of the coolant lines, Diesel Exhaust Fluid (DEF) lines, and electrical connections. Check that all clamps, clips, and tie-wraps are secure and in good condition. Check that the DEF filler cap is secure and that the cap is clean and free from dirt.

i07385598

Water Pump - Inspect

A failed water pump may cause severe engine overheating problems that could result in the following conditions:

- Cracks in the cylinder head
- A piston seizure
- Other potential damage to the engine

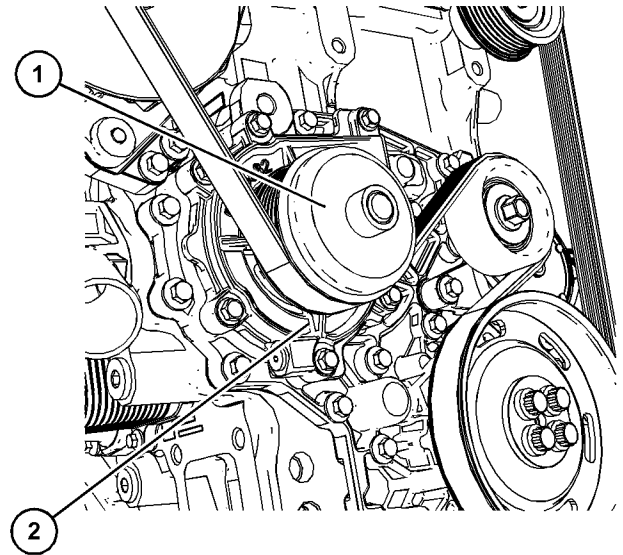

Illustration 137

g06304598

Visually inspect the water pump for leaks between water pump pulley (1) and water pump body (2).

The water pump is not a serviceable item. To install a new water pump, refer to Disassembly and Assembly, "Water Pump - Remove" and Disassembly and Assembly, "Water Pump - Install".

Warranty Section

Warranty Information

i08757138

Emissions Warranty Information

The certifying engine manufacturer warrants to the ultimate purchaser and each subsequent purchaser that:

1. New non-road diesel engines and stationary diesel engines less than 10 L per cylinder (including Tier 1 and Tier 2 marine engines < 37 kW, but excluding locomotive and other marine engines) operated and serviced in the United States and Canada, including all parts of their emission control systems ("emission-related components"), are:
 - a. Designed, built, and equipped so as to conform, at the time of sale, with applicable emission standards prescribed by the United States Environmental Protection Agency (EPA) by way of regulation.
 - b. Free from defects in materials and workmanship in emission-related components that can cause the engine to fail to conform to applicable emission standards for the warranty period.
2. New non-road diesel engines (including Tier 1 and Tier 2 marine propulsion engines < 37 kW and Tier 1 through Tier 4 marine auxiliary engines < 37 kW, but excluding locomotive and other marine engines) operated and serviced in the state of California, including all parts of their emission control systems ("emission-related components"), are:
 - a. Designed, built, and equipped so as to conform, at the time of sale, to all applicable regulations adopted by the California Air Resources Board (ARB).
 - b. Free from defects in materials and workmanship which cause the failure of an emission-related component to be identical in all material respects to the component as described in the engine manufacturer's application for certification for the warranty period.
3. New non-road diesel engines installed in construction machines conforming to the South Korean regulations for construction machines manufactured after January 1, 2015, and operated and serviced in South Korea, including all parts of their emission control systems ("emission related components"), are:
 - a. Designed, built, and equipped so as to conform, at the time of sale, with applicable emission standards prescribed in the Enforcement Rule of the Clean Air Conservation Act promulgated by South Korea MOE.
 - b. Free from defects in materials and workmanship in emission-related components that can cause the engine to fail to conform to applicable emission standards for the warranty period.
4. New China non-road 4 mobile diesel engines operated and serviced in China, including all parts of their emission control systems ("emission related components"), are:
 - a. Designed, built, and equipped so as to conform, at the time of manufacture, sale, and import with applicable emission standards promulgated by Ministry of Ecology and Environment (MEE).
 - b. Free from defects in materials and workmanship in emission-related components that can cause the engine to fail to conform to applicable emission standards for the warranty period.

A detailed explanation of the Emission Control Warranty that is applicable to new non-road and stationary diesel engines, including the components covered and the warranty period, is found in Warranty supplement - Emission warranty parts available at the Perkins engines website. Consult your authorized Perkins distributor to determine if your engine is subject to an Emission Control Warranty, and to obtain a copy of the applicable warranty publication.

(Table 36, contd)

i07677995

Reference Material (Extended Service Contract)

Extended Service Contracts - purchased in minutes, protected for years.

Extended Service Contracts (ESC) protect you from the stress that unexpected repair work brings to your life by covering the cost of getting your engine up and running again. Unlike other extended warranties, Perkins Platinum ESC protects you against all component part failures.

Purchase peace of mind from only £0.03 / \$0.05 / euro 0.04 a day and let an ESC make your dreams a reality.

Why buy an Extended Service Contract?

1. No surprises - total protection from unexpected repair cost (parts, labor, and travel).
2. Enjoy longer lasting product support from Perkins global network.
3. Genuine Perkins parts ensure continued engine performance.
4. Highly trained technicians carry out all repairs.
5. Transferable coverage should you sell your machine.

Flexible coverage provides the right level of protection for your Perkins Engine. Coverage can be extended to 2 years/ 1,000 hours right up to 10 year/ 40,000

You can buy an ESC at any time during standard warranty - even the last day!

Each Perkins Distributor has highly trained and experienced Perkins Product Support Service Technicians. The Support Service is equipped, and available around the clock to get your engine running again with the minimum of downtime. Buying an ESC means that you get all this for free.

To purchase an Extended Service Contract, is quick and simple! Contact your local Perkins Distributor now and the distributor can provide you with a quote in minutes. You can locate your nearest Perkins Distributor by visiting:

www.perkins.com

NOTICE
Dependant upon engine type and application.

Index

A

Additional Messages	16
After Starting Engine	74
After Stopping Engine	90
Aftercooler Core - Clean/Test (Air-To-Air Aftercooler)	116
Aftercooler Core - Inspect	116
Aftertreatment Operation	79
Alarms and Shutoffs	56
Alarms	56
Shutoffs	56
Testing	57
Alternator - Inspect	116
Alternator and Fan Belts - Replace	116

B

Battery - Replace	116
Battery Disconnect Switch (If Equipped)	57
Battery Electrolyte Level - Check	117
Battery or Battery Cable - Disconnect	117
Before Starting Engine	27, 72
Belt - Inspect	118
Belt Tensioner - Check	118
Burn Prevention	21
Batteries	22
Coolant	22
Diesel Fuel	22
Engine and Aftertreatment System	22
Induction System	22
Oils	22

C

Cold Weather Operation	86
Hints for Cold-Weather Operation	86
Idling the Engine	87
Recommendations for Coolant Warm Up	87
Recommendations for the Coolant	87
Viscosity of the Engine Lubrication Oil	87
Cold Weather Starting	72
Coolant (Commercial Heavy-Duty) - Change	119, 123
Drain	119, 123
Fill	122, 126
Flush	122, 126
Coolant (ELC) - Change	127
Drain	127
Fill	130

Flush	130
Coolant Level - Check	131
Coolant level 904J-E36TA ElectropaK Radiator	132
Industrial Open Power Unit (IOPU) Radiators	131
Radiator Cap	131
Crushing Prevention and Cutting Prevention ..	25

D

DEF Filler Screen (Emission Related Component) - Clean	132
Type 1 DEF filler Screen	133
Type 2 DEF Filler Screen	133
DEF Manifold Filters (Emission Related Component) - Replace	134
Type 1 Manifold (DEF Heater)	134
Type 2 Manifold (DEF Heater)	134
Diagnostic Flash Code Retrieval	70
Diagnostic Lamp	70
Diesel Exhaust Fluid (Emission Related Component) - Fill	136
Diesel Exhaust Fluid Filter (Emission Related Component) - Replace	137
Diesel Exhaust Fluid in Cold Weather	89
Diesel Exhaust Fluid Injector (Emission Related Component) - Replace	138
Diesel Exhaust Fluid Tank - Flush	138
Flushing Procedure	138
Required Tools	138
Driven Equipment - Check	140

E

Electrical System	28
Grounding Practices	28
Emergency Stopping	90
Emissions Certification Film	50
Emissions Warranty Information	164
Engaging the Driven Equipment	77
Engine - Clean	140
Aftertreatment	141
Engine Air Cleaner Element - Replace	141
Servicing the Air Cleaner Elements	141
Engine Air Cleaner Service Indicator - Inspect	143
Test the Service Indicator	143
Type 1 Service Indicator	143

Type 2 Service Indicator	143	Fluid Recommendations (General Fuel Information)	96
Engine Air Precleaner - Check/Clean	144	Contamination Control Recommendations for Fuels	103
Engine Diagnostics	70	Diesel Fuel Characteristics	99
Engine Electronics.....	29	Diesel Fuel Requirements	96
Engine Mounts - Inspect.....	144	General Information.....	96
Engine Oil and Filter - Change	146	Foreword	4
Draining the Engine Lubricating Oil From a Standard Oil Pan.....	147	California Proposition 65 Warning.....	4
Draining the Engine Lubricating Oil From an Oil Pan Equipped With a Balancer	147	Literature Information	4
Fill the Oil Pan.....	149	Maintenance	4
Oil and Filter Change Intervals	146	Maintenance Intervals	5
Replace the Oil Filter Element.....	149	Operation	4
Engine Oil Level - Check.....	144	Overhaul	5
After Operating the Engine	145	Safety.....	4
Before Operating the Engine	144	Fuel and the Effect from Cold Weather	88
Engine Oil Sample - Obtain.....	145	Fuel Conservation Practices	77
Obtain the Sample and the Analysis	146	Fuel Related Components in Cold Weather ...	89
Engine Operation	76	Fuel Filters	89
Carbon Dioxide (CO ₂) Emissions Statement.....	77	Fuel Heaters	89
Engine Operation and the Aftertreatment System	76	Fuel Tanks	89
Engine Operation with Active Diagnostic Codes	70	Fuel System - Prime.....	151
Engine Operation with Intermittent Diagnostic Codes	71	Electric Fuel Priming Pump	151
Engine Starting.....	27, 72	Mechanical Fuel Priming Pump.....	152
Engine Stopping	28, 90	Fuel System Primary Filter (Water Separator) Element - Replace.....	152
F		Fuel System Primary Filter (Water Separator) Element for Electric Fuel Priming Pump..	152
Fan Clearance - Check	150	Fuel System Primary Filter (Water Separator) Element for Manual Fuel Priming Pump..	154
904J-E28T Industrial Open Power Unit (IOPU).....	151	Fuel System Primary Filter/Water Separator - Drain	155
904J-E36TA Industrial Open Power Unit (IOPU).....	150	Drain Procedure.....	155
Fault Logging.....	70	Fuel System Secondary Filter - Replace	156
Features and Controls.....	56	Install the Element	157
Fire Prevention and Explosion Prevention.....	23	Remove the Element	156
Ether	24	Fuel Tank Water and Sediment - Drain	157
Fire Extinguisher.....	24	Drain the Water and the Sediment	157
Lines, Tubes, and Hoses	25	Fuel Storage Tanks.....	158
Fluid Recommendations	94, 104	Fuel Tank	157
ELC Cooling System Maintenance.....	106	G	
Engine Oil	94	Gauges and Indicators	57
General Coolant Information	104	Aftertreatment Lamps and gauges	59
General Lubricant Information	94	Indicator Lamps	58
Fluid Recommendations (Diesel Exhaust Fluid (DEF)).....	109	General Hazard Information.....	17
General Information.....	109	Containing Fluid Spillage.....	19
		Diesel Exhaust Fluid.....	21
		Dispose of Waste Properly	21
		Fluid Penetration	19
		Inhalation	20

Pressurized Air and Water.....	18	Engine Indicator Lamps.....	59
Static Electricity Hazard when Fueling with Ultra-low Sulfur Diesel Fuel	19	Mounting and Dismounting	25
General Information	31		
H		O	
High Pressure Fuel Lines	25	Operation Section.....	51
Hoses and Clamps - Inspect/Replace.....	158		
Replace the Hoses and the Clamps	158	P	
I		Plate Locations and Film Locations	49
Important Safety Information.....	2	Serial Number Plate (1).....	49
L		Product Description.....	46
Lifting and Storage	51	904J-E28T and 904J-E28TA Industrial Engines	46
M		904J-E36TA Industrial Engine.....	46
Maintenance Interval Schedule.....	114	Aftermarket Products and Perkins Engines	48
Daily	114	Aftertreatment System.....	48
Every 10 000 Service Hours.....	115	Electronic Engine Features	47
Every 1000 Service Hours.....	114	Engine Cooling and Lubrication	48
Every 2000 Service Hours.....	114	Engine Diagnostics.....	48
Every 3000 Service Hours.....	114	Engine Service Life.....	48
Every 3000 Service Hours or 1 Year	115	Engine Specifications	47
Every 3000 Service Hours or 2 Years	115	Product Identification Information	49
Every 4000 Service Hours.....	115	Product Information Section.....	31
Every 4500 Service Hours.....	115	Product Lifting	51
Every 50 Service Hours.....	114	904J-E28T and 904J-E28TA Industrial Engines	53
Every 500 Service Hours or 1 Year	114	904J-E28T Industrial Open Power Unit (IOPU).....	53
Every 6000 Service Hours.....	115	904J-E36TA ElectropaK	54
Every 6000 Service Hours or 3 Years	115	904J-E36TA Industrial Engine.....	51
Every Week	114	904J-E36TA Industrial Engine Equipped With a Balancer.....	52
When Required.....	114	904J-E36TA IOPU	52
Maintenance Log.....	165	Product Storage (Engine and Aftertreatment)	54
Maintenance Recommendations	111	Aftertreatment.....	55
Maintenance Section.....	92	Condition for Storage.....	54
Model View Illustrations	31, 36, 39, 44	R	
904J-E28T and 904J-E28TA Industrial Engine Views.....	33	Radiator - Clean	159
904J-E28T Industrial Open Power Unit (IOPU).....	42	Radiator Mounts - Inspect	159
904J-E36TA ElectropaK	45	Radiator Restrictions.....	88
904J-E36TA Industrial Engine Views	31, 36	Reference Information.....	50
904J-E36TA Industrial Open Power Unit (IOPU).....	39	Record for Reference	50
Loose or Off Engine Components	35, 38	Reference Information Section	165
Monitoring System (Engine Indicators and Aftertreatment Indicators).....	59	Reference Material (Extended Service Contract).....	166
		Reference Materials	165
		Refill Capacities.....	92

Cooling System.....	93	Fuel System.....	111
DEF System.....	93		
Lubrication System for Engines Equipped With a Balancer Oil Pan.....	92	T	
Lubrication System for Engines Equipped With a Standard Oil Pan	92	Table of Contents	3
		Turbocharger - Inspect.....	160
S			
Safety Messages.....	6, 9, 12	W	
904J-E28T and 904J-E28TA Industrial Engines	7	Walk-Around Inspection	161
904J-E36TA ElectropaK	14	High-Pressure Fuel Lines	162
904J-E36TA Industrial Engine.....	6	Inspect the Engine for Leaks and for Loose Connections	161
904J-E36TA Industrial Engines With A Balancer.....	10	Warranty Information.....	164
904J-E36TA Industrial Open Power Unit (IOPU).....	13	Warranty Section.....	164
Ether Warning.....	8, 11	Water Pump - Inspect.....	162
Ether Warning 4	16	Welding on Engines with Electronic Controls	111
Hand (High Pressure) 2.....	8, 11		
Hand (High Pressure) 3.....	15		
Hot Fluid Under Pressure 2	15		
Universal Warning 1	7, 10, 14		
Safety Section	6		
Selective Catalytic Reduction Warning System.....	79		
Warning Indicators.....	79		
Warning Levels	79		
Warning Strategy.....	79		
Self-Diagnostics	70		
Sensors and Electrical Components.....	60		
904J-E28T and 904J-E28TA Industrial Engines	66		
904J-E36TA Industrial Engine.....	61		
Severe Service Application	113		
Environmental Factors.....	113		
Incorrect Maintenance Procedures	113		
Incorrect Operating Procedures	113		
Starting Motor - Inspect.....	160		
Starting the Engine.....	73		
Starting the Engine	73		
Starting with Jump Start Cables (Do Not Use This Procedure in Hazardous Locations that have Explosive Atmospheres)	73		
Stopping the Engine	90		
Delayed Engine Shutdown (if Equipped)	90		
System Pressure Release.....	111		
Coolant System	111		
Engine Oil	111		

Product and Dealer Information

Note: For product identification plate locations, see the section "Product Identification Information" in the Operation and Maintenance Manual.

Delivery Date: _____

Product Information

Model: _____

Product Identification Number: _____

Engine Serial Number: _____

Transmission Serial Number: _____

Generator Serial Number: _____

Attachment Serial Numbers: _____

Attachment Information: _____

Customer Equipment Number: _____

Dealer Equipment Number: _____

Dealer Information

Name: _____ Branch: _____

Address: _____

Dealer Contact

Phone Number

Hours

Sales: _____

Parts: _____

Service: _____

M0092609
©2024 Perkins Engines Company Limited
All Rights Reserved