

Cat® Advansys™

TIPS AND ADAPTERS

FASTER, EASIER, SAFER



HIGHER PRODUCTIVITY HAMMERLESS GROUND ENGAGING TOOLS (GET)

CAT® ADVANSYS™ 70-200 TIPS AND ADAPTERS ARE BUILT SPECIFICALLY FOR DEMANDING HIGH PRODUCTION APPLICATIONS, WITH EASIER PENETRATION INTO THE PILE AND FASTER CYCLE TIMES.



Select the right tip based on penetration and wear life



CAT ADVANSYS™ TIP AND ADAPTER SYSTEM

Cast retention pin means no separate retention pin to buy or lose during tip replacements. The tip loads on the adapter nose, never putting the cast retention lugs under stress or wear.

ABRASION RESISTANCE ↑

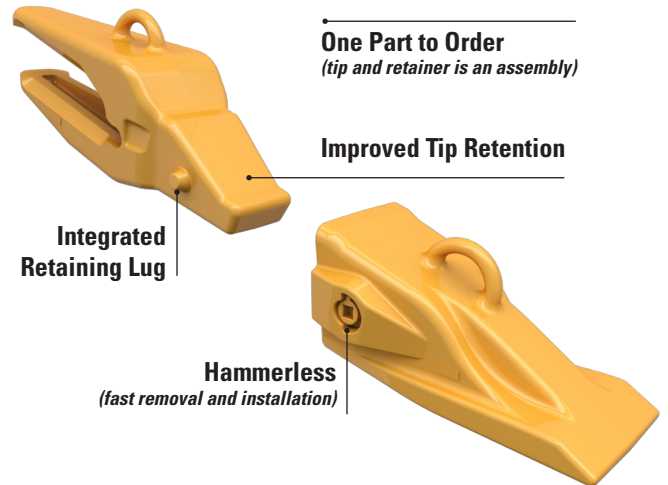
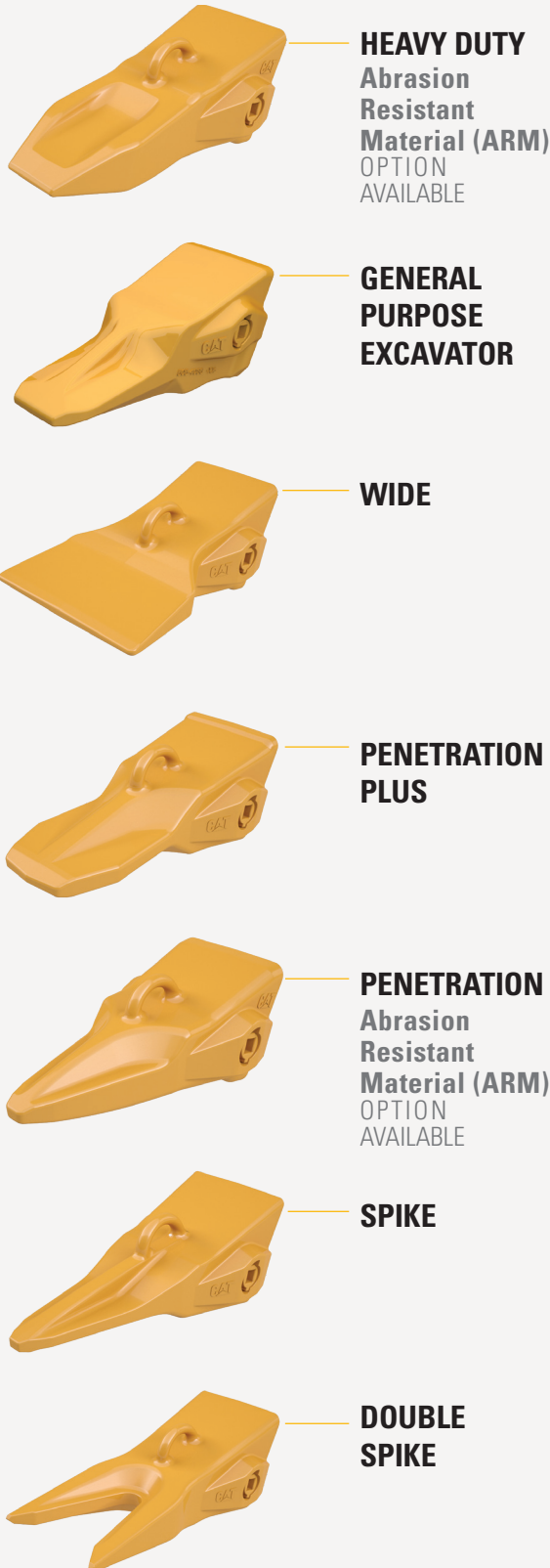

MOVE MORE MATERIAL WITH LESS DOWNTIME

Built for your Cat® 311-390 hydraulic excavator, the Cat Advansys™ hammerless system simplifies installation with integrated retention components and streamlines retrofitting with adapters that drop into the same space as Cat® K Series.

ADVANSYS SYSTEM PERFORMANCE:

- + Exclusive performance features offer less drag and higher productivity.
- + New tip shapes put wear material where you need it most.

ADVANSYS SYSTEM RELIABILITY:

- + Stronger adapter noses result in up to a 50% stress reduction.
- + Improved adapter nose geometry reduces sliding wear on adapter nose surfaces.
- + Improved tip shapes shadow the adapter straps and welds for longer adapter life.

ADVANSYS INSTALLATION AND REMOVAL:

- + Retainer lock requires no special tools for quickest tip removal and installation.
- + A half-turn of retention locks and unlocks the Cat® CapSure™ retention.
- + Retention components come installed in tips.

DESIGNED FOR THE TOUGHEST JOBS

Nose Geometry Design Features

- + Asymmetrical nose geometry reduces sliding wear on adapter nose surfaces, extending the life of the adapter.
- + The asymmetrical design ensures a reliable fit even when the adapter surface becomes worn.

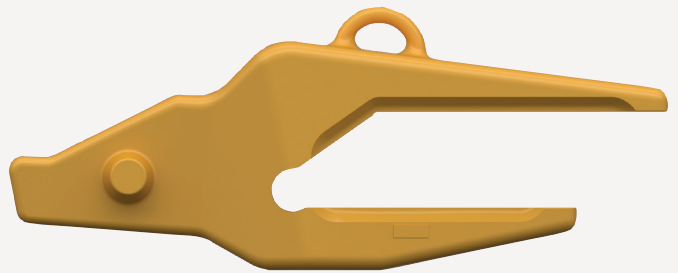

Change Out Tips Quickly & Easily

CapSure™ hammerless retention requires no special tools. Just turn the retainer 180° to install or remove the tips.

- 1** Turn retainer 180° clockwise to lock.

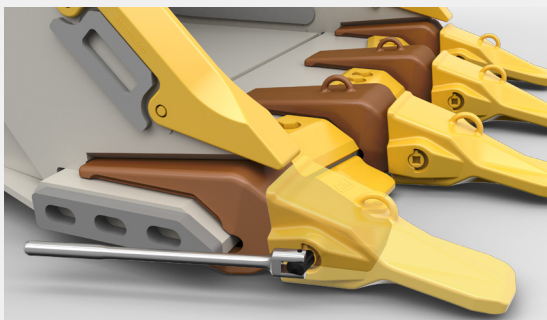

- 2** Turn retainer 180° counterclockwise to unlock.



- + **Up to a 15% productivity increase*** in trenching applications due to improved tip and adapter geometry
- + **Exclusive performance features such as tapered tip sides reduce drag and increase productivity**
- + **Increased fuel efficiency**

Wider top surface reduces drag on the tip and adapter side as the tip moves through the soil. Reduced side drag results in less force required to move the bucket through the soil.

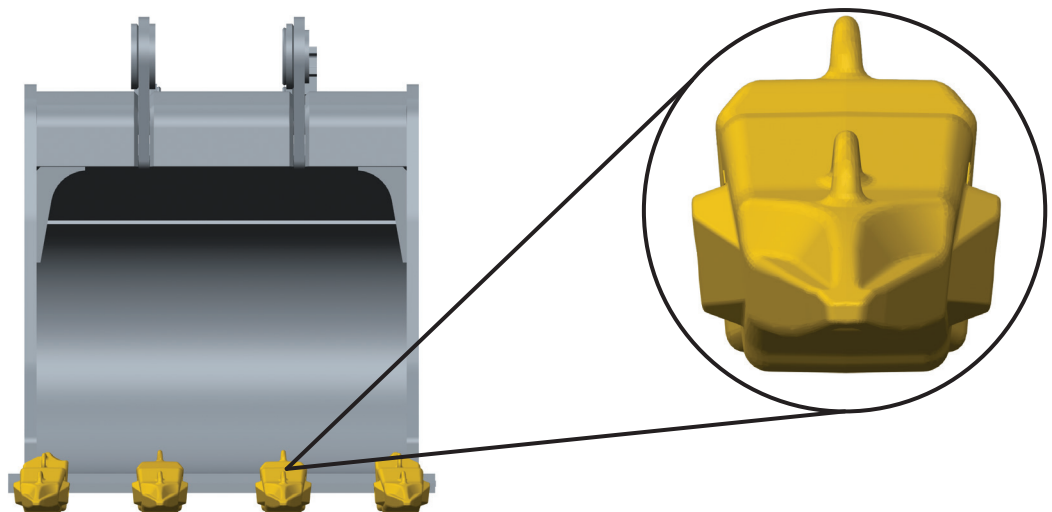

*Compared to legacy Cat products



CAT® ADVANSYS™

TIPS AND ADAPTERS

SAFE, SIMPLE, EFFICIENT

Take your operation to the next level. The Cat Advansys™ system gives you improved job site safety, easier removal and installation, longer tip life and better penetration for improved fuel efficiency.*

Your Cat dealer can help you choose the Advansys system that offers the right balance for your application.

*Compared to legacy Cat tips and adapters

PEDJ0339-04

© 2023 Caterpillar. All Rights Reserved. CAT, CATERPILLAR, LET'S DO THE WORK, their respective logos, "Caterpillar Corporate Yellow", the "Power Edge" and Cat "Modern Hex" trade dress as well as corporate and product identity used herein, are trademarks of Caterpillar and may not be used without permission.

