



# Cat<sup>®</sup> PM820, PM822, PM825

## Cold Planers

*The high-production Cat<sup>®</sup> PM820, PM822 and PM825 Cold Planers with integrated Cat GRADE technology, automated systems and the latest System K rotors help you meet the demands of the job with efficiency. A comfortable work environment and intuitive controls are designed to keep operators productive throughout the day. Easy access to daily service points helps simplify maintenance. Multiple options are available to enhance versatility for high production applications.*

### Fuel-Efficient Power

- Powerful Cat<sup>®</sup> C18 twin-turbo engine meets U.S. EPA Tier 4 Final, EU Stage V emission standards
- Engine Idle Speed Management and multiple rotor speeds allow for optimal output and demand on the engine
- Variable speed cooling fan operates at the lowest possible speed for quiet and efficient cooling
- Automatic load sensing on the rotor adjusts milling speed to prevent stalls and while maintaining high production

### Optimal Maneuverability and Control

- The reliable track undercarriage leverages proven designs from Cat dozers and uses an automatic tensioning system for consistent performance and longer track life
- A robust propel system features two independent propel pumps that drive two crawler tracks each, in a high-traction, cross-drive pattern
- Automatic traction control maintains consistent speed in the most challenging applications
- Four steering modes with advanced alignment and tracking provides precise steering and helps reduce track wear
- Electronically switch rotor speeds during operation

### Durable and Dependable Cutting System

- The rotor drive system features a heavy-duty dry clutch, automatic belt-tensioning to prevent slippage, and two high tensile (five-rib) belts to drive the rotor
- Durable, reinforced cutting chamber
- Ample access and lighting for bit changes and rotor service
- Hardened full length side plate skis, inboard ski shoe, and anti-slab shoes are designed to reduce wear and maintenance

### High Production System K Rotors Optimize Cutting Capability

- Cat System K rotors can be used for numerous applications and feature efficient material flow with a uniform cutting pattern
- A tapered dual-retention design secures toolholders in place without a retaining pin, bolt or setscrew, speeding up replacement and eliminating the need for fasteners or torquing
- Toolholders, base blocks and kicker paddles are built from high strength alloy steel that's abrasion resistant for extended life
- Optional Cat Diamond bits are designed to stay sharp and last significantly longer than a carbide bit (ideal for bituminous applications without obstacles such as interstates or motorways)



# Cat® PM820, PM822, PM825 Cold Planers

---

## Efficient Material Removal

- High-capacity conveyors efficiently remove milled material with outstanding discharge control
- Belt speed can be adjusted to match material type and production rate, while the built in “boost” feature provides a temporary surge in belt speed to eject material faster and farther
- A wide opening and seamless belt effectively clear the rotor chamber
- The belt reverses direction to easily remove material from the conveyor during clean-up, and easy-access covers allow for quick inspection and cleaning of the rollers
- Conveyor hydraulically folds for transportation and maintenance

## Easy Operation

- Access integrated technology and automated systems through easy-to-use controls and a highly intuitive touchscreen interface
- Ground displays utilize a robust mounting system that easily drops into multiple mounting locations without tightening clamps or fasteners and quickly detaches for storage without disconnecting harnesses
- Displays provide access to gauge cluster, operating information, grade and slope, remote camera feeds, machine controls and diagnostics
- Four, ground-level 16-button keypads give operators convenient access to various machine functions
  - Rear keypads include controls for leg height, water spray, side plates, moldboard, rear door and rear steering
  - Flush mounted front keypads include controls for the conveyor, sideplates, anti-slab, high pressure washdown, water spray, inboard ski and fuel fill pump
- High-visibility, color LED lightbars help crews easily identify water tank level day or night and from further distances (included in optional enhanced LED light package)

## Comfortable Work Environment

- The workstation is designed for all-day comfort with adjustable consoles, large cushioned arm rests, hip rests, and optional anti-fatigue floor mats
- Telescoping center console displays bring the touchscreens fully within reach for comfortable interaction
- The ladder and gate design allows unimpeded ascent/descent from the operator platform and the retractable right-side handrail simplifies maneuverability around obstacles
- Work areas are illuminated for nighttime operation with backlit keypads, standard wide-dispersion LED work lights and an optional enhanced LED lighting package
- The optional single post, forward-folding powered canopy with overhead LED lighting, integrated side extensions and optional windscreens quickly stows and redeploys during operation with the push of a button to clear overhead obstacles
- Choose from pedestal or suspension seat options
- Maximize dust removal from the working areas with the optional dust abatement system

## Boost Precision and Productivity with Cat Technology

- Achieve accurate, repeatable and automatic cutting precision with the integrated Cat Grade and Slope system
- Obtain full control of grade and slope from any machine display
- Easily adjust grade control values and sensors through the touchscreen displays
- Adjust the speed at which the rotor drops into the cut for optimal machine control
- Set and automate transitions in/out of cuts and save settings for future jobs
- Clear obstacles in the cutting path with ease using the obstacle jump feature
- Enhance for full 3D milling operation (additional hardware required)

## Simplified Service

- Daily maintenance areas are easily accessible through large service doors and a power hood with walk-in access to the engine compartment
- Track components do not require routine maintenance and easy to replace track pads help lower service costs
- Standard ground-level controls and an optional hydraulically-operated rotor turning device with pendant simplify bit removal and replacement
- High and low pressure washdown options connect to the onboard water tank for convenient clean-up
- The accessory drive system allows use of select machine functions when the engine is off
- Electrical system wiring is color-coded and numbered for easy identification and wrapped in a protective, abrasion-resistant nylon braid for longer life
- Monitor fluid conditions with regular sampling to help extend change intervals up to 500 hours engine oil, 6000 hours hydraulic oil and 12000 hours coolant
- Built-in diagnostics monitor machine systems, alert the operator of performance issues and provide troubleshooting information
- VisionLink takes the guesswork out of managing your entire fleet—regardless of size or equipment manufacturer\*—by providing maintenance needs, machine hours, location, fuel usage, idle time, diagnostic codes, and more through interactive dashboards on your mobile device or desktop, helping you make informed decisions that lower costs, simplify maintenance, and improve safety and security on your jobsite
- Remote Flash allows you to update onboard software without a technician being present, allowing you to initiate software updates when convenient to help increase your overall operating efficiency\*\*
- Remote Troubleshoot allows your Cat dealer to perform diagnostic testing on your connected machine remotely\*\*
- Convenient parts availability, dealer locations and service repair kits simplify ordering of high wear components

\* Data field availability can vary by equipment manufacturer and is provided through an application programming interface (API).

\*\* Must be within cell range coverage.

## Convenience Features

Cat cold planers offer a variety of features and options designed to make daily operation and maintenance tasks easier.

- Access daily/project and lifetime totals for distance, area and hours milled through the onboard machine displays
- Pause and resume machine functions with the push of a button during truck exchanges
- Hooks for water hose storage
- Lockable, water-tight storage compartments
- Angled water fill connection
- Easily accessible shovel holder
- Top and side view rotor depth indicators
- Optional magnetic paint can holders

# Cat® PM820, PM822, PM825 Cold Planers

## Standard and Optional Equipment

Features, standard and optional equipment may vary by region. Please check with your local Cat dealer for specific offerings and availability in your area.

	Standard	Optional		Standard	Optional
<b>OPERATOR ENVIRONMENT</b>			<b>CONVEYOR</b>		
Ground control keypads	✓		Grease tensioner (primary conveyor)	✓	
Single high-resolution LCD touchscreen display	✓		Hydraulically folding conveyor	✓	
Dual high-resolution LCD touchscreen displays		✓	Conveyor speed boost feature	✓	
12-volt power receptacle	✓		Dust extraction system		✓
Dual operator consoles with vertical adjustment	✓		Additional spray bars (dust control)		✓
Dual operator consoles with vertical, sideways, and rotational adjustment		✓	Conveyor release valve		✓
Hydraulically folding canopy with LEDs and side extensions		✓	<b>ROTOR SYSTEM</b>		
Anti-fatigue floor mats		✓	Automatic plunge-cut	✓	
Adjustable pedestal seats		✓	Automatic grade and slope transition feature	✓	
Adjustable suspension seats		✓	Obstacle jump	✓	
Lockable 109x45x33 cm (43x18x13in) storage chest		✓	Three cutting speeds	✓	
Windscreens (front and rear)		✓	System K Rotor – Coarse (25 mm)		✓
<b>CAT® CONNECT TECHNOLOGY</b>			System K Rotor – Coarse (18 mm)		✓
Remote Flash	✓		System K Rotor – Standard (15 mm)		✓
Remote Troubleshoot	✓		System K Rotor – Fine (10 mm) (PM822 and PM825 only)		✓
Cat Grade with Grade and Slope	✓		System K Rotor – Fine (8 mm)		✓
VisionLink® telematics	✓		System K Rotor – Micro (6 mm)		✓
Inboard ski		✓	System H Rotor – Micro (6 x 2 mm) (PM820 and PM822 only)		✓
Single sonic grade control sensor		✓	Cat Diamond bits		✓
Sonic averaging system for grade control		✓	Bit bucket trays		✓
High-resolution LCD touchscreen display (for ground level grade controls)		✓	Pneumatic bit removal tool		✓
			Toolholder extractor		✓
			Powered rotor turning device	✓	
			Pendant control for rotor turning device		✓
			<b>POWERTRAIN</b>		
			Engine Idle Speed Management	✓	
			High capacity cooling system	✓	
			Automatic Load Control	✓	
			CE certificate		✓

Continued

## Standard and Optional Equipment

Features, standard and optional equipment may vary by region. Please check with your local Cat dealer for specific offerings and availability in your area.

	Standard	Optional
<b>HYDRAULIC SYSTEM</b>		
Two independent hydraulic propel circuits	✓	
Traction control	✓	
Cat Bio HYDO™ Advanced biodegradable hydraulic oil		✓
High ambient hydraulic oil		✓
<b>SERVICE AND MAINTENANCE</b>		
Sampling ports for Scheduled Oil Sampling (S·O·S <sup>SM</sup> )	✓	
Power hood	✓	
Platform-level engine oil dipsticks	✓	
Rotor chamber water spray system	✓	
Air compressor	✓	
Accessory drive system	✓	
3400 L (898 gal) onboard water tank	✓	
Side water fill valve	✓	
Water tank transfer pump		✓
High pressure washdown		✓
Low pressure washdown		✓
Fuel transfer pump		✓
Fast fill fuel tank		✓
<b>SAFETY AND SECURITY</b>		
Platform handrails	✓	
Signaling/warning horn	✓	
Wide-dispersion LED work lighting	✓	
Enhanced LED lighting package (perimeter, rotor service and water level)		✓
Magnetic LED work light		✓
Warning beacon (fixed or magnetic mount)		✓
Truck signal lights		✓
Remote cameras (rear back up, front conveyor, 2 magnetic mount)		✓

# Cat® PM820, PM822, PM825 Cold Planers

## Technical Specifications

### Weights

	PM820		PM822		PM825	
Operating Weight	34 088 kg	75,152 lb	34 565 kg	76,202 lb	35 175 kg	77,548 lb
Transport Weight	32 859 kg	72,442 lb	33 336 kg	73,493 lb	33 946 kg	74,838 lb

Weights shown are approximate and include:

- Operating weight includes base machine with 75 kg (165 lb) operator, all standard equipment, power canopy, inboard ski, dust abatement system, high pressure wash system, 15 mm rotor, pedestal seats, floor mats, two ground displays, 50% water, 50% fuel and full operating fluids.
- Transport weight includes base machine, all standard equipment, power canopy, inboard ski, dust abatement system, high pressure wash system, 15 mm rotor, pedestal seats, floor mats, two ground displays, empty water, full fuel and other operating fluids.

### Powertrain

Engine Model	Cat C18 twin-turbo	
Cylinders	6	
Emission Standards	U.S. EPA Tier 4 Final, EU Stage V	
Gross Power – SAE J1995:2014	601 kW	806 hp
Engine Power – ISO 14396:2002	595 kW	798 hp
Build Number	02C	
Maximum Milling Speed	100 m/min	328 ft/min
Maximum Travel Speed	6 km/h	3.7 mph

### Operating Dimensions

<b>A</b> Overall Length (conveyor raised)	14.52 m	47.64 ft
<b>B</b> Maximum Machine Width		
PM820	3.11 m	10.20 ft
PM822	3.11 m	10.20 ft
PM825	3.36 m	11.02 ft
<b>B'</b> Minimum Machine Width		
PM820	2.52 m	8.27 ft
PM822	2.74 m	8.99 ft
PM825	3.01 m	9.88 ft
<b>C</b> Maximum Height (conveyor raised)	5.23 m	17.16 ft
<b>D</b> Height to Optional Canopy	4.05 m	13.29 ft
<b>E</b> Height (canopy lowered)	3.00 m	9.84 ft
<b>F</b> Maximum Truck Clearance	4.86 m	15.94 ft
<b>G</b> Conveyor Length	8.38 m	27.49 ft
<b>H</b> Conveyor Swing	±60° from center	

### Shipping Dimensions

<b>I</b> Transport Length	12.43 m	40.78 ft
<b>B'</b> Transport Width		
PM820	2.52 m	8.27 ft
PM822	2.74 m	8.99 ft
PM825	3.01 m	9.88 ft
<b>E</b> Transport Height (canopy lowered)	3.00 m	9.84 ft
<b>J</b> Length (track to track)	6.69 m	21.95 ft
<b>K</b> Length of Machine (rear to front track)	7.32 m	24.02 ft
<b>L</b> Length of Base Machine	8.33 m	27.33 ft

### Cutting System

Milling Width		
PM820	2010 mm	79.1 in
PM822	2235 mm	88.0 in
PM825	2505 mm	98.6 in
Number of Bits (15 mm spacing)		
PM820	170	
PM822	185	
PM825	203	
Maximum Cutting Depth	330 mm	13.0 in
Rotor Speeds	100 / 109 / 118 rpm	
Minimum Left Cutting Radius	2.00 m	6.56 ft
Minimum Right Cutting Radius		
PM820	2.00 m	6.56 ft
PM822	1.80 m	5.91 ft
PM825	1.50 m	4.92 ft

### Service Refill Capacities

Fuel Tank	1108 L	292.7 gal
Cooling System	104 L	27.5 gal
Engine Oil	65 L	17.2 gal
Hydraulic Oil	113 L	29.9 gal
Water Tank	3400 L	898.2 gal

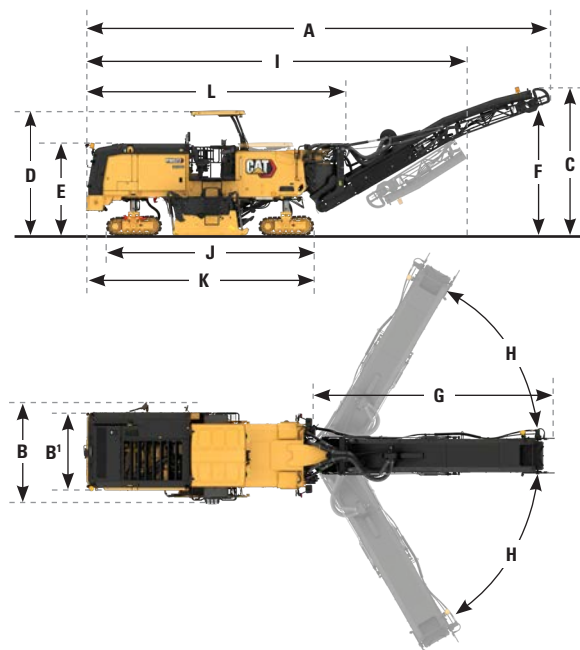

## Environmental Declaration

The following information applies to the machine at the time of final manufacture as configured for sale in the regions covered in this document. The content of this declaration is valid as of the date issued; however, content related to machine features and specifications are subject to change without notice. For additional information, please see the machine's Operation and Maintenance Manual.

For more information on sustainability in action and our progress, please visit [www.caterpillar.com/en/company/sustainability.html](http://www.caterpillar.com/en/company/sustainability.html).

### ENGINE

- The Cat C18 meets U.S. EPA Tier 4 Final and EU Stage V emission standards.
- Cat diesel engines are required to use ULSD (ultra-low sulfur diesel fuel with 15 ppm of sulfur or less) or ULSD blended with the following lower-carbon intensity fuels\* up to:
  - ✓ 20% biodiesel FAME (fatty acid methyl ester)
  - ✓ 100% renewable diesel, HVO (hydrotreated vegetable oil) and GTL (gas-to-liquid) fuels

Refer to guidelines for successful application. Please consult your Cat dealer or "Caterpillar Machine Fluids Recommendations" (SEBU6250) for details.

\*Tailpipe greenhouse gas emissions from lower-carbon intensity fuels are essentially the same as traditional fuels.

### PAINT

- Based on best available knowledge, the maximum allowable concentration, measured in parts per million (PPM), of the following heavy metals in paint are:
  - Barium < 0.01%
  - Cadmium < 0.01%
  - Chromium < 0.01%
  - Lead < 0.01%

### SOUND PERFORMANCE

With cooling fan speed at 70% of maximum value:

Operator Sound Pressure Level (ISO 6396:2008) – 97 dB(A)

Exterior Sound Power Level (ISO 6395:2008) – 113 dB(A)

- The dynamic operator sound pressure level measurements are performed according to the dynamic test procedures that are specified in ISO 6396:2008.
- The dynamic spectator sound power level measurements are performed according to the dynamic test procedures that are specified in ISO 6395:2008.
- Hearing protection may be needed when operating with an open operator station for extended periods or in a noisy environment.

### OILS AND FLUIDS

- Caterpillar factory fills with ethylene glycol coolants. Cat Diesel Engine Antifreeze/Coolant (DEAC) and Cat Extended Life Coolant (ELC) can be recycled. Consult your Cat dealer for more information.
- Cat Bio HYDO™ Advanced is an EU Ecolabel approved biodegradable hydraulic oil.
- Additional fluids are likely to be present, please consult the Operations and Maintenance Manual or the Application and Installation guide for complete fluid recommendations and maintenance intervals.

### FEATURES AND TECHNOLOGY

- The following features and technology may contribute to fuel savings and/or carbon reduction. Features may vary. Consult your Cat dealer for details.
  - Advanced hydraulic systems balance power and efficiency
  - Adjustable rotor speeds allow for milling at lower engine speeds
  - Engine Idle Speed Management allows the machine to idle at the lowest possible RPM
  - Variable speed cooling fan operates at the lowest speed for optimal cooling
  - System K rotor efficiently removes material and reduces drag
  - Diamond bits are designed to stay sharp, last significantly longer than a carbide bit and maintains cutting efficiency
  - The Standby/Resume feature pauses machine functions and lowers engine speed during truck exchanges
  - Extended maintenance intervals reduce fluid and filter consumption
  - Remote Flash and Remote Troubleshoot

### RECYCLABILITY

- The materials included in machines are categorized as below with approximate weight percentage. Because of variations of product configurations, the following values in the table may vary.

Material Type	Weight Percentage
Steel	82.28%
Iron	6.09%
Nonferrous Metal	3.15%
Mixed Metal	0.24%
Mixed-Metal and Nonmetal	2.09%
Plastic	2.74%
Rubber	1.06%
Mixed Nonmetallic	0.02%
Fluid	1.05%
Other	0.61%
Uncategorized	0.35%
Total	100%

- A machine with higher recyclability rate will ensure more efficient usage of valuable natural resources and enhance End-of-Life value of the product. According to ISO 16714 (Earthmoving machinery – Recyclability and recoverability – Terminology and calculation method), recyclability rate is defined as percentage by mass (mass fraction in percent) of the new machine potentially able to be recycled, reused or both.

All parts in the bill of material are first evaluated by component type based on a list of components defined by the ISO 16714 and Japan CEMA (Construction Equipment Manufacturers Association) standards. Remaining parts are further evaluated for recyclability based on material type.

Because of variations of product configurations, the following value in the table may vary.

Recyclability – 96%

# Cat® PM820, PM822, PM825 Cold Planers

---

For more complete information on Cat products, dealer services, and industry solutions, visit us on the web at [www.cat.com](http://www.cat.com)

© 2024 Caterpillar  
All rights reserved

Materials and specifications are subject to change without notice. Featured machines in photos may include additional equipment.  
See your Cat dealer for available options.

CAT, CATERPILLAR, LET'S DO THE WORK, their respective logos, "Caterpillar Corporate Yellow," the "Power Edge" and Cat "Modern Hex" trade dress as well as corporate and product identity used herein, are trademarks of Caterpillar and may not be used without permission.

VisionLink is a trademark of Caterpillar Inc., registered in the United States and in other countries.

QEHQ3235 (05-2024)  
Build Number: 02C  
(U.S. EPA Tier 4 Final, EU Stage V)

