



980

Wheel Loader

Technical Specifications

Not all attachments available in all regions. Consult your Cat® dealer for specific configurations available in your region.

Table of Contents

Specifications	2
Engine	2
Buckets	2
Weight	2
Operating Specifications	2
Transmission	2
Hydraulic System	3
Brakes	3
Axles	3
Service Refill Capacities	3
Cab	3
Sound	3
Air Conditioning System	3
Dimensions	4
Tire Options	5
Bucket Fill Factors and Selection Guide	7
Operating Specifications – Buckets	9
Fork Specifications	25
Standard and Optional Equipment	53
980 Environmental Declaration	55
980 Waste & Scrap Handler Configuration	56
Key Features and Benefits	56
Tire Options	58
Operating Specifications – Buckets	60
Fork Specifications	68
980 Forestry Machine Configuration	80
Key Features and Benefits	80
Tire Options	82
Fork Specifications	83
980 Steel Mill Configuration	87
Key Features and Benefits	87
Tire Options	89
Operating Specifications – Buckets	90
980 Block Handler Configuration	92
Key Features and Benefits	92
Tire Options	94
Fork Specifications	95

980 Wheel Loader Specifications

Engine

Engine Model	Cat® C13	
Engine Power @ 1,700 rpm	313 kW	420 hp
ISO 14396:2002	426 hp (metric)	
Gross Power @ 1,700 rpm	317 kW	425 hp
SAE J1995:2014	431 hp (metric)	
Net Power @ 1,700 rpm	293 kW	393 hp
ISO 9249:2007, SAE J1349:2011	398 hp (metric)	
Engine Torque (1,200 rpm)	2185 N·m	1,612 lbf·ft
ISO 14396:2002		
Gross Torque (1,200 rpm)	2206 N·m	1,627 lbf·ft
SAE J1995:2014		
Net Torque (1,100 rpm)	2086 N·m	1,539 lbf·ft
ISO 9249:2007, SAE J1349:2011		
Bore	130 mm	5.12 in
Stroke	157 mm	6.18 in
Displacement	12.5 L	763 in ³

- Cat engine meets U.S. EPA Tier 4 Final, EU Stage V, Korea Stage V, China Nonroad Stage IV and Japan 2014 emission standards.
- The net power advertised is the power available at the flywheel when the engine is equipped with fan, alternator, air cleaner and aftertreatment.
- Cat diesel engines are required to use ULSD (ultra-low sulfur diesel fuel with 15 ppm of sulfur or less) or ULSD blended with the following lower-carbon intensity fuels** up to:
 - 20% biodiesel FAME (fatty acid methyl ester)*
 - 100% renewable diesel, HVO (hydrotreated vegetable oil) and GTL (gas-to-liquid) fuels
 Refer to guidelines for successful application. Please consult your Cat dealer or “Caterpillar Machine Fluids Recommendations” (SEBU6250) for details.
 - * Engines with no aftertreatment devices can use higher blends, up to 100% biodiesel.
 - ** Tailpipe greenhouse gas emissions from lower-carbon intensity fuels are essentially the same as traditional fuels.

Buckets

Bucket Capacities	4.0-14.5 m ³	5.25-19.0 yd ³
-------------------	-------------------------	---------------------------

Weight

Operating Weight	30 344 kg	66,877 lb
------------------	-----------	-----------

- Weight based on a machine configuration with Bridgestone 29.5R25 VSNT L4 radial tires, full fluids, operator, standard counterweight, ride control, cold start, roading fenders, Product Link™, open differential axles (front/rear), secondary steering, sound suppression and a 5.4 m³ (7.1 yd³) general purpose bucket with BOCE.

Operating Specifications

Static Tipping Load – Full 40° Turn		
With Tire Deflection	19 706 kg	43,432 lb
No Tire Deflection	20 965 kg	46,208 lb
Breakout Force	227 kN	51,008 lbf

- For a machine configuration as defined under “Weight.”
- Full compliance to ISO 14397-1:2007 Sections 1 thru 6, which requires 2% verification between calculations and testing.

Transmission

Forward 1	6.9 km/h	4.3 mph
Forward 2	13.3 km/h	8.3 mph
Forward 3	23.5 km/h	14.6 mph
Forward 4	39.5 km/h	24.5 mph
Reverse 1	7.8 km/h	4.8 mph
Reverse 2	15.2 km/h	9.4 mph
Reverse 3	26.9 km/h	16.7 mph
Reverse 4	39.5 km/h	24.5 mph

- Maximum travel speed in standard vehicle with empty bucket and standard L4 tires with 935 mm (37 in) roll radius.

980 Wheel Loader Specifications

Hydraulic System

Implement Pump Type	Variable Displacement Piston, load sensing	
Implement System:		
Maximum Pump Output (2,250 rpm)	449 L/min	119 gal/min
Maximum Operating Pressure	34 300 kPa	4,975 psi
Optional 3 rd Function Maximum Flow	240 L/min	63 gal/min
Optional 3 rd Function Maximum Pressure at Work Tool	20 684 kPa	3,000 psi
Hydraulic Cycle Time with Rated Payload:		
Raise from Carry Position	5.3 sec	
Dump, at Maximum Raise	1.7 sec	
Lower, Empty, Float Down	3.1 sec	
Total	10.1 sec	

Brakes

Brakes	Brakes meet ISO 3450:2011 standards
--------	-------------------------------------

Axles

Front	Fixed
Rear	Oscillating

Service Refill Capacities

Fuel Tank	426 L	112.5 gal
DEF Tank	21 L	5.5 gal
Cooling System	52 L	13.7 gal
Crankcase	37 L	9.8 gal
Transmission	77 L	20.3 gal
Differentials and Final Drives – Front	84 L	22.2 gal
Differentials and Final Drives – Rear	84 L	22.2 gal
Hydraulic Tank	153 L	40.4 gal

Cab

ROPS/FOPS	ROPS/FOPS meet ISO 3471:2008 and ISO 3449:2005 Level II standards
-----------	---

Sound Performance

Operator Sound Pressure Level (ISO 6396:2008)	72 dB(A)
Exterior Sound Power Level (ISO 6395:2008)	112 dB(A)
Operator Sound Pressure Level (ISO 6396:2008)*	72 dB(A)
Exterior Sound Power Level (ISO 6395:2008)**	109 dB(A)

*Including countries that adopt the EU and UK Directives
 **EU Noise Directive 2000/14/EC and UK Noise Regulation 2001 No. 1701

Air Conditioning System

- The air conditioning system on this machine contains the fluorinated greenhouse gas refrigerant R134a (Global Warming Potential = 1430). The system contains 1.6 kg (3.52 lb) of refrigerant which has a CO₂ equivalent 2.288 metric tonnes (2.522 tons).

980 Wheel Loader Specifications

Dimensions

All dimensions are approximate.

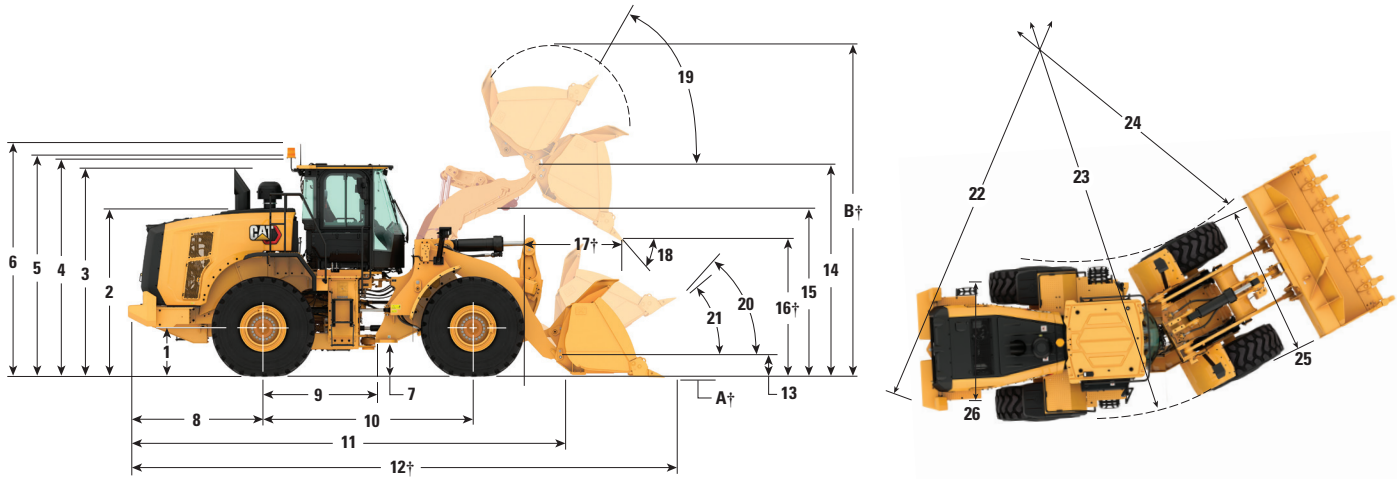

	Standard Lift		High Lift	
1 Height to Axle Centerline	899 mm	2'11"	899 mm	2'11"
2 Height to Top of Hood	3064 mm	10'1"	3064 mm	10'1"
3 Height to Top of Exhaust Pipe	3764 mm	12'5"	3764 mm	12'5"
4 Height to Top of ROPS	3829 mm	12'7"	3829 mm	12'7"
5 Height to Top of Product Link Antenna	3835 mm	12'7"	3835 mm	12'7"
6 Height to Top of Warning Beacon	4108 mm	13'6"	4108 mm	13'6"
7 Ground Clearance	456 mm	1'5"	456 mm	1'5"
8 Center Line of Rear Axle to Edge of Counterweight	2661 mm	8'9"	2661 mm	8'9"
9 Center Line of Rear Axle to Hitch	1900 mm	6'3"	1900 mm	6'3"
10 Wheelbase	3800 mm	12'6"	3800 mm	12'6"
11 Overall Length (without bucket)	8155 mm	26'10"	8355 mm	27'5"
12 Shipping Length (with bucket level on ground)*†	9673 mm	31'9"	9875 mm	32'5"
13 Hinge Pin Height at Carry Height	632 mm	2'0"	682 mm	2'2"
14 Hinge Pin Height at Maximum Lift	4554 mm	14'11"	4775 mm	15'7"
15 Lift Arm Clearance at Maximum Lift	3881 mm	12'8"	4125 mm	13'6"
16 Dump Clearance at Maximum Lift and 45° Discharge*†	3287 mm	10'9"	3508 mm	11'6"
17 Reach at Maximum Lift and 45° Discharge*†	1481 mm	4'10"	1484 mm	4'10"
18 Dump Angle at Maximum Lift and Dump (on stops)*	52 degrees		55 degrees	
19 Rack Back at Maximum Lift*	61 degrees		61 degrees	
20 Rack Back at Carry Height*	48 degrees		50 degrees	
21 Rack Back at Ground*	40 degrees		40 degrees	
22 Clearance Circle (dia) to Counterweight	13 692 mm	45'0"	13 692 mm	45'0"
23 Clearance Circle (dia) to Outside of Tires	13 700 mm	45'0"	13 700 mm	45'0"
24 Clearance Circle (dia) to Inside of Tires	7180 mm	23'7"	7180 mm	23'7"
25 Width over Tires (unloaded)	3240 mm	10'8"	3240 mm	10'8"
Width over Tires (loaded)	3260 mm	10'9"	3260 mm	10'9"
26 Tread Width	2440 mm	8'0"	2440 mm	8'0"

†Dimensions are listed in Operating Specifications charts.

All height and tire related dimensions are with Bridgestone 29.5R25 VSNT L4 radial tires (see Tire Option Chart for other tires). "Width over Tires" dimensions are over the bulge and include growth.

• All dimensions are approximate and based on machine equipped with 5.4 m³ (7.1 yd³) general purpose bucket with BOCE and Bridgestone 29.5R25 VSNT L4 radial tires. (see Operating Specifications for other buckets)

980 Wheel Loader Specifications

Tire Options

Tire Brand	Bridgestone	Michelin	Michelin	Michelin	Bridgestone	Michelin
Tire Size	29.5R25	29.5R25	29.5R25	29.5R25	29.5R25	29.5R25
Tread Type	L-4	L-4	L-5	L-5	L-3	L-3
Tread Pattern	VSNT	XLDD1	XLDD2	XMINED2	VJT	XHA2
Width over Tires – Maximum (empty)*	3240 mm 10'8"	3258 mm 10'9"	3256 mm 10'9"	3275 mm 10'9"	3263 mm 10'9"	3270 mm 10'9"
Width over Tires – Maximum (loaded)*	3260 mm 10'9"	3302 mm 10'10"	3296 mm 10'10"	3294 mm 10'10"	3289 mm 10'10"	3296 mm 10'10"
Change in Vertical Dimensions (average of front and rear)		-7 mm -0.3"	-6 mm -0.2"	5 mm 0.2"	-23 mm -0.9"	-40 mm -1.6"
Change in Horizontal Reach		-1 mm 0"	3 mm 0.1"	3 mm 0.1"	20 mm 0.8"	23 mm 0.9"
Change in Clearance Circle to Outside of Tires		42 mm 1.7"	36 mm 1.4"	34 mm 1.3"	29 mm 1.1"	36 mm 1.4"
Change in Clearance Circle to Inside of Tires		-42 mm -1.7"	-36 mm -1.4"	-34 mm -1.3"	-29 mm -1.1"	-36 mm -1.4"
Change in Operating Weight (without Ballast)		-156 kg -344 lb	208 kg 459 lb	532 kg 1,173 lb	-684 kg -1,508 lb	-700 kg -1,544 lb
Change in Static Tipping Load – Straight		-119 kg -262 lb	158 kg 349 lb	405 kg 892 lb	-520 kg -1,147 lb	-532 kg -1,174 lb
Change in Static Tipping Load – Articulated		-103 kg -228 lb	138 kg 304 lb	352 kg 777 lb	-453 kg -998 lb	-463 kg -1,022 lb
Rear Axle Oscillation Angle	±13 degrees	±13 degrees	±13 degrees	±13 degrees	±13 degrees	±13 degrees
Maximum Single-wheel Rise and Fall	549 mm 1'10"	549 mm 1'10"	549 mm 1'10"	549 mm 1'10"	549 mm 1'10"	549 mm 1'10"

*Width over tire bulge and includes tire growth.

Tire Brand	Bridgestone	Bridgestone	Maxam	Maxam	Maxam	Brawler
Tire Size	29.5R25	29.5R25	29.5R25	29.5R25	29.5R25	29.5-25
Tread Type	L-5	L-5	L-3	L-4	L-5	Solid
Tread Pattern	VSDT	VSDL	MS302	MS405DX	MS503	Traction/Smooth
Width over Tires – Maximum (empty)*	3272 mm 10'9"	3250 mm 10'8"	3270 mm 10'9"	3256 mm 10'9"	3268 mm 10'9"	3227 mm 10'8"
Width over Tires – Maximum (loaded)*	3301 mm 10'10"	3275 mm 10'9"	3290 mm 10'10"	3282 mm 10'10"	3304 mm 10'11"	3230 mm 10'8"
Change in Vertical Dimensions (average of front and rear)	4 mm 0.1"	20 mm 0.8"	-19 mm -0.8"	-33 mm -1.3"	-6 mm -0.2"	9 mm 0.4"
Change in Horizontal Reach	0 mm 0"	-10 mm -0.4"	6 mm 0.2"	19 mm 0.7"	-3 mm -0.1"	30 mm 1.2"
Change in Clearance Circle to Outside of Tires	41 mm 1.6"	15 mm 0.6"	30 mm 1.2"	22 mm 0.9"	44 mm 1.7"	-30 mm -1.2"
Change in Clearance Circle to Inside of Tires	-41 mm -1.6"	-15 mm -0.6"	-30 mm -1.2"	-22 mm -0.9"	-44 mm -1.7"	30 mm 1.2"
Change in Operating Weight (without Ballast)	500 kg 1,103 lb	708 kg 1,561 lb	-528 kg -1,164 lb	-388 kg -856 lb	252 kg 556 lb	5772 kg 12,727 lb
Change in Static Tipping Load – Straight	380 kg 838 lb	538 kg 1,187 lb	-402 kg -885 lb	-295 kg -651 lb	192 kg 423 lb	4390 kg 9,679 lb
Change in Static Tipping Load – Articulated	331 kg 730 lb	469 kg 1,033 lb	-350 kg -771 lb	-257 kg -566 lb	167 kg 368 lb	3821 kg 8,425 lb
Rear Axle Oscillation Angle	±13 degrees	±13 degrees	±13 degrees	±13 degrees	±13 degrees	±8 degrees
Maximum Single-wheel Rise and Fall	549 mm 1'10"	549 mm 1'10"	549 mm 1'10"	549 mm 1'10"	549 mm 1'10"	340 mm 1'1"

*Width over tire bulge and includes tire growth.

980 Wheel Loader Specifications

Tire Options

Tire Brand	Michelin	Bridgestone	Bridgestone	Maxam
Tire Size	875/65R29	875/65R29	875/65R29	875/65R29
Tread Type	L-3	L-3	L-4	L-4
Tread Pattern	XHA2	VTS	VLTS	MS405DX
Width over Tires – Maximum (empty)*	3373 mm 11'1"	3341 mm 11'0"	3344 mm 11'0"	3357 mm 11'1"
Width over Tires – Maximum (loaded)*	3384 mm 11'2"	3359 mm 11'1"	3366 mm 11'1"	3382 mm 11'2"
Change in Vertical Dimensions (average of front and rear)	-25 mm -1"	-19 mm -0.8"	-16 mm -0.6"	-34 mm -1.3"
Change in Horizontal Reach	18 mm 0.7"	20 mm 0.8"	19 mm 0.7"	19 mm 0.7"
Change in Clearance Circle to Outside of Tires	124 mm 4.9"	99 mm 3.9"	106 mm 4.2"	122 mm 4.8"
Change in Clearance Circle to Inside of Tires	-124 mm -4.9"	-99 mm -3.9"	-106 mm -4.2"	-122 mm -4.8"
Change in Operating Weight (without Ballast)	-40 kg -88 lb	240 kg 529 lb	316 kg 697 lb	308 kg 679 lb
Change in Static Tipping Load – Straight	-30 kg -67 lb	183 kg 402 lb	240 kg 530 lb	234 kg 516 lb
Change in Static Tipping Load – Articulated	-26 kg -58 lb	159 kg 350 lb	209 kg 461 lb	204 kg 450 lb
Rear Axle Oscillation Angle	±8 degrees	±8 degrees	±8 degrees	±8 degrees
Maximum Single-wheel Rise and Fall	340 mm 1'1"	340 mm 1'1"	340 mm 1'1"	340 mm 1'1"

*Width over tire bulge and includes tire growth.

980 Wheel Loader Specifications

Bucket Fill Factors and Selection Guide

The bucket size must be chosen based on the density of the material and on the expected fill factor. The Cat Performance Series Buckets with longer floor, larger bucket opening, increased repository angle, rounded side boards and integrated spill guard demonstrate fill factors significantly higher than previous generation or non-Cat buckets. The actual volume handled by the machine is thus often larger than the rated capacity.

Loose Material		Fill Factor (%)*	Material Density
Earth/Clay		115	1.5-1.7
Sand and Gravel		115	1.5-1.7
Aggregate:	25-76 mm (1 to 3 in)	110	1.6-1.7
	19 mm (0.75 in) and smaller	105	1.8
Rock:	76 mm (3 in) and larger	100	1.6

*As a % of ISO 7546:1983 rated capacity.

Note: Fill Factors achieved will also depend on whether the product is washed or not washed.

Material Density		kg/m ³	900	1000	1100	1200	1300	1400	1500	1600	1700	1800	1900	2000	2100	2200	2300	2400				
Standard Linkage	Pin On	General Purpose	5.4 m ³ (7 yd ³)							6.2 m ³ (8 yd ³)				5.4 m ³ (7 yd ³)								
			5.7 m ³ (7.5 yd ³)							6.6 m ³ (8.5 yd ³)				5.7 m ³ (7.5 yd ³)								
			6 m ³ (7.75 yd ³)							6.9 m ³ (9 yd ³)				6 m ³ (7.75 yd ³)								
			6.4 m ³ (8.25 yd ³)						7.4 m ³ (9.75 yd ³)				6.4 m ³ (8.25 yd ³)									
Standard Linkage	Hook On	General Purpose	5.4 m ³ (7 yd ³)							6.2 m ³ (8 yd ³)				5.4 m ³ (7 yd ³)								
			5.7 m ³ (7.5 yd ³)							6.6 m ³ (8.5 yd ³)				5.7 m ³ (7.5 yd ³)								
High Lift	Pin On	General Purpose	5.4 m ³ (7 yd ³)							6.2 m ³ (8 yd ³)				5.4 m ³ (7 yd ³)								
			5.7 m ³ (7.5 yd ³)							6.6 m ³ (8.5 yd ³)				5.7 m ³ (7.5 yd ³)								
			6 m ³ (7.75 yd ³)							6.9 m ³ (9 yd ³)				6 m ³ (7.75 yd ³)								
			6.4 m ³ (8.25 yd ³)						7.4 m ³ (9.75 yd ³)				6.4 m ³ (8.25 yd ³)									
Aggregate Handler	Pin On	General Purpose	5.4 m ³ (7 yd ³)								6.2 m ³ (8 yd ³)				5.4 m ³ (7 yd ³)							
			5.7 m ³ (7.5 yd ³)									6.6 m ³ (8.5 yd ³)				5.7 m ³ (7.5 yd ³)						
			6 m ³ (7.75 yd ³)									6.9 m ³ (9 yd ³)				6 m ³ (7.75 yd ³)						
			6.4 m ³ (8.25 yd ³)							7.4 m ³ (9.75 yd ³)				6.4 m ³ (8.25 yd ³)								
Material Density	lb/yd ³	1,517	1,685	1,854	2,022	2,191	2,359	2,528	2,696	2,865	3,033	3,202	3,370	3,539	3,707	3,876	4,044					
Bucket Fill Factor																						
115% 110% 105% 100% 95%																						



Note: All buckets are showing Bolt-On Edges.

980 Wheel Loader Specifications

Bucket Fill Factors and Selection Guide

The bucket size must be chosen based on the density of the material and on the expected fill factor. The Cat Performance Series Buckets with longer floor, larger bucket opening, increased repository angle, rounded side boards and integrated spill guard demonstrate fill factors significantly higher than previous generation or non-Cat buckets. The actual volume handled by the machine is thus often larger than the rated capacity.

Loose Material		Fill Factor (%)*	Material Density
Earth/Clay		115	1.5-1.7
Sand and Gravel		115	1.5-1.7
Aggregate:	25-76 mm (1 to 3 in)	110	1.6-1.7
	19 mm (0.75 in) and smaller	105	1.8
Rock:	76 mm (3 in) and larger	100	1.6

*As a % of ISO 7546:1983 rated capacity.

Note: Fill Factors achieved will also depend on whether the product is washed or not washed.

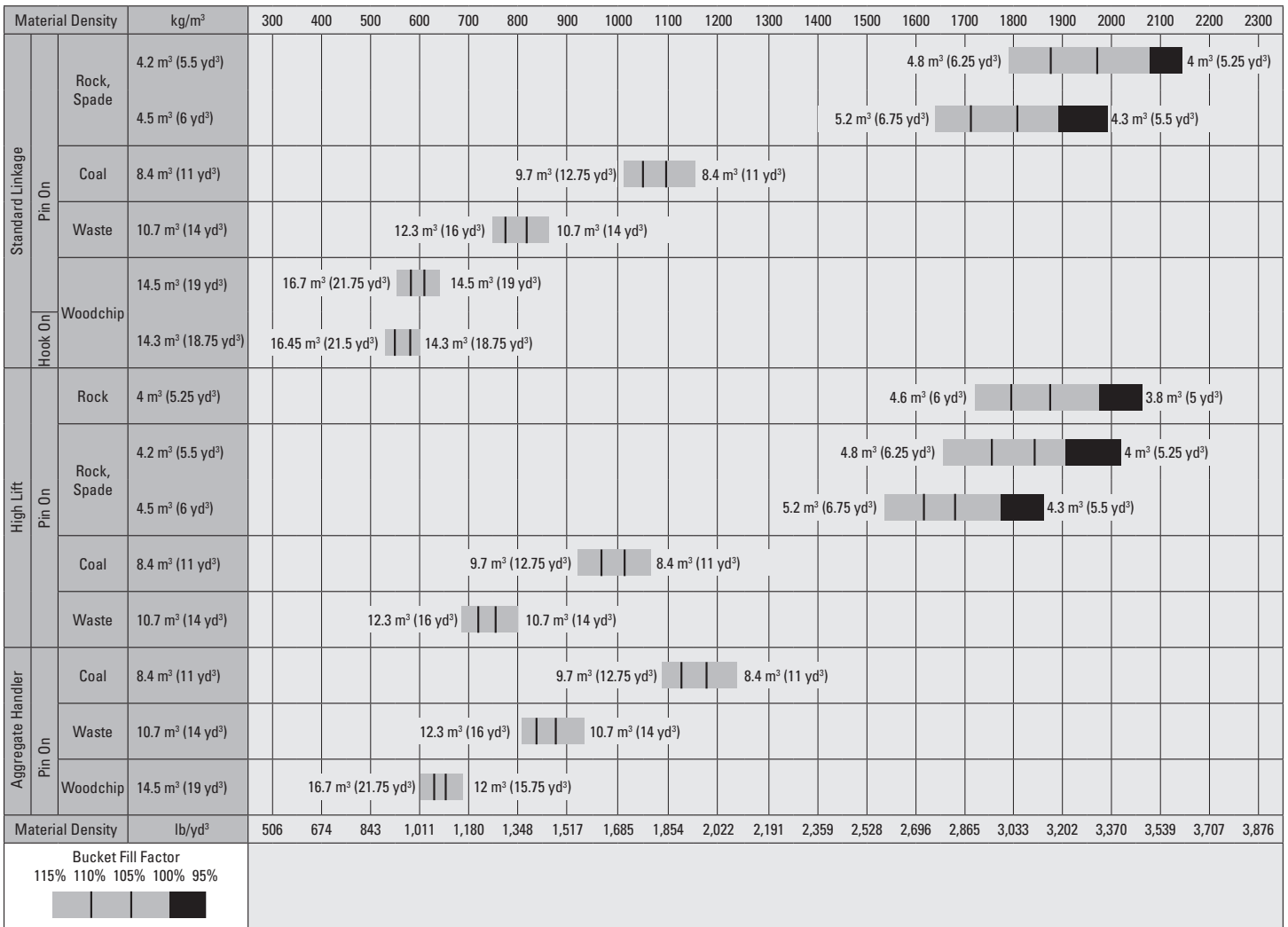

Note: All buckets are showing Bolt-On Edges.

980 Wheel Loader Specifications

Operating Specifications – Buckets

Linkage		Standard Linkage			
Bucket Type		General Purpose – Pin On			
Edge Type		Bolt-On Cutting Edges	Teeth and Segments	Bolt-On Cutting Edges	Teeth and Segments
Capacity – Rated	m ³	5.40	5.40	5.70	5.70
	yd ³	7.00	7.00	7.50	7.50
Capacity – Rated at 110% Fill Factor	m ³	5.90	5.90	6.30	6.30
	yd ³	7.75	7.75	8.25	8.25
Width	mm	3447	3535	3447	3535
	ft/in	11'3"	11'7"	11'3"	11'7"
16† Dump Clearance at Maximum Lift and 45° Discharge	mm	3287	3121	3219	3051
	ft/in	10'9"	10'2"	10'6"	10'0"
17† Reach at Maximum Lift and 45° Discharge	mm	1481	1618	1529	1664
	ft/in	4'10"	5'3"	5'0"	5'5"
Reach at Level Lift Arm and Bucket Level	mm	2966	3177	3050	3261
	ft/in	9'8"	10'5"	10'0"	10'8"
A† Digging Depth	mm	88	88	88	88
	in	3.4"	3.4"	3.4"	3.4"
12† Overall Length	mm	9673	9915	9757	9999
	ft/in	31'9"	32'7"	32'1"	32'10"
B† Overall Height with Bucket at Maximum Lift	mm	6435	6435	6258	6258
	ft/in	21'2"	21'2"	20'7"	20'7"
Loader Clearance Circle Radius with Bucket at Carry Position	mm	7612	7725	7635	7749
	ft/in	25'0"	25'5"	25'1"	25'6"
Static Tipping Load, Straight (ISO)*	kg	22 809	22 623	22 564	22 377
	lb	50,271	49,861	49,732	49,321
Static Tipping Load, Straight (Rigid Tire)*	kg	24 219	24 032	23 977	23 788
	lb	53,380	52,967	52,845	52,429
Static Tipping Load, Articulated (ISO)*	kg	19 706	19 520	19 478	19 291
	lb	43,432	43,022	42,931	42,518
Static Tipping Load, Articulated (Rigid Tire)*	kg	20 965	20 777	20 740	20 552
	lb	46,208	45,794	45,713	45,296
Breakout Force (§)	kN	227	224	214	211
	lbf	51,008	50,477	48,132	47,613
Operating Weight*	kg	30 344	30 482	30 427	30 565
	lb	66,877	67,182	67,060	67,365

* Static tipping loads and operating weights shown are based on a machine configuration with Bridgestone 29.5R25 VSNT L4 radial tires, full fluids, operator, counterweight, ride control, cold start, roading fenders, power train guard, secondary steering and sound suppression.

† Illustration shown with Dimension charts.

*** Rock bucket specifications are given on Bridgestone 29.5R25 VSDT L5 Radial tires.

(§) Measured 102 mm (4") behind tip of cutting edge with bucket hinge pin as pivot point in accordance with SAE J732C.

(§) Specifications and ratings conform to all applicable standards recommended by the Society of Automotive Engineers, including SAE Standard J732C governing loader ratings.

(ISO) Full compliance to ISO 14397-1:2007 Sections 1 thru 6, which requires 2% verification between calculations and testing.

(Rigid Tire) Compliance to ISO 14397-1:2007 Sections 1 thru 5.

Other buckets are available and offerings vary by region. Consult your local Cat dealer for further details.

980 Wheel Loader Specifications

Operating Specifications – Buckets

Linkage		Standard Linkage			
Bucket Type		General Purpose – Pin On			
Edge Type		Bolt-On Cutting Edges	Teeth and Segments	Bolt-On Cutting Edges	Teeth and Segments
Capacity – Rated	m ³	6.00	6.00	6.40	6.40
	yd ³	7.75	7.75	8.25	8.25
Capacity – Rated at 110% Fill Factor	m ³	6.60	6.60	7.00	7.00
	yd ³	8.75	8.75	9.25	9.25
Width	mm	3447	3535	3447	3535
	ft/in	11'3"	11'7"	11'3"	11'7"
16 † Dump Clearance at Maximum Lift and 45° Discharge	mm	3201	3034	3145	2977
	ft/in	10'6"	9'11"	10'3"	9'9"
17 † Reach at Maximum Lift and 45° Discharge	mm	1551	1686	1603	1737
	ft/in	5'1"	5'6"	5'3"	5'8"
Reach at Level Lift Arm and Bucket Level	mm	3078	3289	3155	3366
	ft/in	10'1"	10'9"	10'4"	11'0"
A † Digging Depth	mm	88	88	88	88
	in	3.4"	3.4"	3.4"	3.4"
12 † Overall Length	mm	9785	10 027	9862	10 104
	ft/in	32'2"	32'11"	32'5"	33'2"
B † Overall Height with Bucket at Maximum Lift	mm	6284	6284	6604	6604
	ft/in	20'8"	20'8"	21'8"	21'8"
Loader Clearance Circle Radius with Bucket at Carry Position	mm	7643	7757	7664	7779
	ft/in	25'1"	25'6"	25'2"	25'7"
Static Tipping Load, Straight (ISO)*	kg	22 424	22 237	22 253	22 064
	lb	49,423	49,011	49,046	48,631
Static Tipping Load, Straight (Rigid Tire)*	kg	23 839	23 649	23 676	23 485
	lb	52,541	52,124	52,182	51,762
Static Tipping Load, Articulated (ISO)*	kg	19 343	19 155	19 183	18 994
	lb	42,632	42,219	42,280	41,864
Static Tipping Load, Articulated (Rigid Tire)*	kg	20 608	20 418	20 457	20 266
	lb	45,420	45,002	45,087	44,667
Breakout Force (§)	kN	210	207	199	197
	lbf	47,182	46,666	44,880	44,374
Operating Weight*	kg	30 523	30 661	30 585	30 723
	lb	67,272	67,577	67,408	67,713

* Static tipping loads and operating weights shown are based on a machine configuration with Bridgestone 29.5R25 VSNT L4 radial tires, full fluids, operator, counterweight, ride control, cold start, roading fenders, power train guard, secondary steering and sound suppression.

† Illustration shown with Dimension charts.

*** Rock bucket specifications are given on Bridgestone 29.5R25 VSDT L5 Radial tires.

(§) Measured 102 mm (4") behind tip of cutting edge with bucket hinge pin as pivot point in accordance with SAE J732C.

(§) Specifications and ratings conform to all applicable standards recommended by the Society of Automotive Engineers, including SAE Standard J732C governing loader ratings.

(ISO) Full compliance to ISO 14397-1:2007 Sections 1 thru 6, which requires 2% verification between calculations and testing.

(Rigid Tire) Compliance to ISO 14397-1:2007 Sections 1 thru 5.

Other buckets are available and offerings vary by region. Consult your local Cat dealer for further details.

980 Wheel Loader Specifications

Operating Specifications – Buckets (continued)

Linkage		Standard Linkage			
Bucket Type		General Purpose – Pin On – Abrasion			
Edge Type		Bolt-On Cutting Edges	Teeth and Segments	Bolt-On Cutting Edges	Teeth and Segments
Capacity – Rated	m ³	5.70	5.70	6.00	6.00
	yd ³	7.50	7.50	7.75	7.75
Capacity – Rated at 110% Fill Factor	m ³	6.30	6.30	6.60	6.60
	yd ³	8.25	8.25	8.75	8.75
Width	mm	3447	3535	3447	3546
	ft/in	11'3"	11'7"	11'3"	11'7"
16† Dump Clearance at Maximum Lift and 45° Discharge	mm	3219	3051	3201	3037
	ft/in	10'6"	10'0"	10'6"	9'11"
17† Reach at Maximum Lift and 45° Discharge	mm	1529	1664	1550	1685
	ft/in	5'0"	5'5"	5'1"	5'6"
Reach at Level Lift Arm and Bucket Level	mm	3050	3261	3077	3286
	ft/in	10'0"	10'8"	10'1"	10'9"
A† Digging Depth	mm	88	88	88	88
	in	3.4"	3.4"	3.4"	3.4"
12† Overall Length	mm	9757	9999	9784	10 021
	ft/in	32'1"	32'10"	32'2"	32'11"
B† Overall Height with Bucket at Maximum Lift	mm	6258	6258	6524	6524
	ft/in	20'7"	20'7"	21'5"	21'5"
Loader Clearance Circle Radius with Bucket at Carry Position	mm	7635	7749	7642	7760
	ft/in	25'1"	25'6"	25'1"	25'6"
Static Tipping Load, Straight (ISO)*	kg	22 405	22 218	22 350	22 189
	lb	49,381	48,969	49,259	48,906
Static Tipping Load, Straight (Rigid Tire)*	kg	23 815	23 626	23 754	23 592
	lb	52,489	52,073	52,355	51,998
Static Tipping Load, Articulated (ISO)*	kg	19 319	19 132	19 279	19 118
	lb	42,580	42,167	42,491	42,137
Static Tipping Load, Articulated (Rigid Tire)*	kg	20 579	20 390	20 535	20 373
	lb	45,357	44,941	45,259	44,903
Breakout Force (§)	kN	213	211	210	208
	lbf	48,005	47,485	47,198	46,738
Operating Weight*	kg	30 573	30 711	30 522	30 639
	lb	67,382	67,687	67,269	67,528

* Static tipping loads and operating weights shown are based on a machine configuration with Bridgestone 29.5R25 VSNT L4 radial tires, full fluids, operator, counterweight, ride control, cold start, roading fenders, power train guard, secondary steering and sound suppression.

† Illustration shown with Dimension charts.

*** Rock bucket specifications are given on Bridgestone 29.5R25 VSDT L5 Radial tires.

(§) Measured 102 mm (4") behind tip of cutting edge with bucket hinge pin as pivot point in accordance with SAE J732C.

(§) Specifications and ratings conform to all applicable standards recommended by the Society of Automotive Engineers, including SAE Standard J732C governing loader ratings.

(ISO) Full compliance to ISO 14397-1:2007 Sections 1 thru 6, which requires 2% verification between calculations and testing.

(Rigid Tire) Compliance to ISO 14397-1:2007 Sections 1 thru 5.

Other buckets are available and offerings vary by region. Consult your local Cat dealer for further details.

980 Wheel Loader Specifications

Operating Specifications – Buckets (continued)

Linkage		Standard Linkage		
Bucket Type		Flat Floor – Pin On		Flat Floor – Pin On – Light Material (Coal)
Edge Type		Bolt-On Cutting Edges	Teeth and Segments	Bolt-On Cutting Edges
Capacity – Rated	m ³	5.70	5.70	8.40
	yd ³	7.50	7.50	11.00
Capacity – Rated at 110% Fill Factor	m ³	6.30	6.30	9.20
	yd ³	8.25	8.25	12.00
Width	mm	3447	3535	3638
	ft/in	11'3"	11'7"	11'11"
16 † Dump Clearance at Maximum Lift and 45° Discharge	mm	3120	2943	2936
	ft/in	10'2"	9'7"	9'7"
17 † Reach at Maximum Lift and 45° Discharge	mm	1444	1566	1628
	ft/in	4'8"	5'1"	5'4"
Reach at Level Lift Arm and Bucket Level	mm	3075	3286	3335
	ft/in	10'1"	10'9"	10'11"
A † Digging Depth	mm	88	88	88
	in	3.4"	3.4"	3.4"
12 † Overall Length	mm	9782	10 024	10 042
	ft/in	32'2"	32'11"	33'0"
B † Overall Height with Bucket at Maximum Lift	mm	6257	6257	6781
	ft/in	20'7"	20'7"	22'3"
Loader Clearance Circle Radius with Bucket at Carry Position	mm	7642	7756	7802
	ft/in	25'1"	25'6"	25'8"
Static Tipping Load, Straight (ISO)*	kg	22 062	21 878	21 915
	lb	48,626	48,220	48,314
Static Tipping Load, Straight (Rigid Tire)*	kg	23 432	23 246	23,387
	lb	51,644	51,234	51,559
Static Tipping Load, Articulated (ISO)*	kg	19 030	18 846	18 842
	lb	41,943	41,536	41,540
Static Tipping Load, Articulated (Rigid Tire)*	kg	20 254	20 068	20 164
	lb	44,640	44,230	44,454
Breakout Force (§)	kN	210	208	178
	lbf	47,288	46,772	40,069
Operating Weight*	kg	30 552	30 690	30 851
	lb	67,336	67,641	68,013

*Static tipping loads and operating weights shown are based on a machine configuration with Bridgestone 29.5R25 VSNT L4 radial tires, full fluids, operator, counterweight, ride control, cold start, roading fenders, power train guard, secondary steering and sound suppression.

† Illustration shown with Dimension charts.

***Rock bucket specifications are given on Bridgestone 29.5R25 VSDT L5 Radial tires.

(§) Measured 102 mm (4") behind tip of cutting edge with bucket hinge pin as pivot point in accordance with SAE J732C.

(§) Specifications and ratings conform to all applicable standards recommended by the Society of Automotive Engineers, including SAE Standard J732C governing loader ratings.

(ISO) Full compliance to ISO 14397-1:2007 Sections 1 thru 6, which requires 2% verification between calculations and testing.

(Rigid Tire) Compliance to ISO 14397-1:2007 Sections 1 thru 5.

Other buckets are available and offerings vary by region. Consult your local Cat dealer for further details.

980 Wheel Loader Specifications

Operating Specifications – Buckets (continued)

Linkage		Standard Linkage	
Bucket Type		Rock, Spade*** – Pin On	
Edge Type		Teeth and Segments	Teeth and Segments
Capacity – Rated	m ³	4.40	4.50
	yd ³	5.75	6.00
Capacity – Rated at 110% Fill Factor	m ³	4.80	5.00
	yd ³	6.25	6.50
Width	mm	3524	3524
	ft/in	11'6"	11'6"
16† Dump Clearance at Maximum Lift and 45° Discharge	mm	3134	3134
	ft/in	10'3"	10'3"
17† Reach at Maximum Lift and 45° Discharge	mm	1768	1768
	ft/in	5'9"	5'9"
Reach at Level Lift Arm and Bucket Level	mm	3278	3278
	ft/in	10'9"	10'9"
A† Digging Depth	mm	83	83
	in	3.2"	3.2"
12† Overall Length	mm	9990	9990
	ft/in	32'10"	32'10"
B† Overall Height with Bucket at Maximum Lift	mm	6209	6209
	ft/in	20'5"	20'5"
Loader Clearance Circle Radius with Bucket at Carry Position	mm	7738	7738
	ft/in	25'5"	25'5"
Static Tipping Load, Straight (ISO)*	kg	23 435	23 076
	lb	51,651	50,874
Static Tipping Load, Straight (Rigid Tire)*	kg	24 871	24 523
	lb	54,817	54,064
Static Tipping Load, Articulated (ISO)*	kg	20 232	19 867
	lb	44,593	43,801
Static Tipping Load, Articulated (Rigid Tire)*	kg	21 513	21 158
	lb	47,415	46,646
Breakout Force (§)	kN	213	211
	lbf	47,885	47,563
Operating Weight*	kg	31 030	31 455
	lb	68,390	69,345

* Static tipping loads and operating weights shown are based on a machine configuration with Bridgestone 29.5R25 VSNT L4 radial tires, full fluids, operator, counterweight, ride control, cold start, roading fenders, power train guard, secondary steering and sound suppression.

† Illustration shown with Dimension charts.

*** Rock bucket specifications are given on Bridgestone 29.5R25 VSDT L5 Radial tires.

(§) Measured 102 mm (4") behind tip of cutting edge with bucket hinge pin as pivot point in accordance with SAE J732C.

(§) Specifications and ratings conform to all applicable standards recommended by the Society of Automotive Engineers, including SAE Standard J732C governing loader ratings.

(ISO) Full compliance to ISO 14397-1:2007 Sections 1 thru 6, which requires 2% verification between calculations and testing.

(Rigid Tire) Compliance to ISO 14397-1:2007 Sections 1 thru 5.

Other buckets are available and offerings vary by region. Consult your local Cat dealer for further details.

980 Wheel Loader Specifications

Operating Specifications – Buckets *(continued)*

Linkage		Standard Linkage			
Bucket Type		General Purpose – Hook On – Fusion™			
Edge Type		Bolt-On Cutting Edges	Teeth and Segments	Bolt-On Cutting Edges	Teeth and Segments
Capacity – Rated	m ³	5.40	5.40	5.70	5.70
	yd ³	7.00	7.00	7.50	7.50
Capacity – Rated at 110% Fill Factor	m ³	5.90	5.90	6.30	6.30
	yd ³	7.75	7.75	8.25	8.25
Width	mm	3447	3535	3447	3535
	ft/in	11'3"	11'7"	11'3"	11'7"
16 † Dump Clearance at Maximum Lift and 45° Discharge	mm	3183	3017	3117	2950
	ft/in	10'5"	9'10"	10'2"	9'8"
17 † Reach at Maximum Lift and 45° Discharge	mm	1588	1724	1640	1775
	ft/in	5'2"	5'7"	5'4"	5'9"
Reach at Level Lift Arm and Bucket Level	mm	3116	3327	3200	3411
	ft/in	10'2"	10'11"	10'6"	11'2"
A † Digging Depth	mm	93	93	93	93
	in	3.6"	3.6"	3.6"	3.6"
12 † Overall Length	mm	9827	10 069	9911	10 153
	ft/in	32'3"	33'1"	32'7"	33'4"
B † Overall Height with Bucket at Maximum Lift	mm	6532	6532	6599	6599
	ft/in	21'6"	21'6"	21'8"	21'8"
Loader Clearance Circle Radius with Bucket at Carry Position	mm	7694	7817	7721	7845
	ft/in	25'3"	25'8"	25'4"	25'9"
Static Tipping Load, Straight (ISO)*	kg	21 361	21 177	21 136	20 950
	lb	47,080	46,674	46,584	46,175
Static Tipping Load, Straight (Rigid Tire)*	kg	22 728	22 542	22 511	22 324
	lb	50,092	49,682	49,615	49,202
Static Tipping Load, Articulated (ISO)*	kg	18 354	18 169	18 140	17 954
	lb	40,452	40,046	39,981	39,572
Static Tipping Load, Articulated (Rigid Tire)*	kg	19 576	19 390	19 372	19 185
	lb	43,147	42,737	42,697	42,284
Breakout Force (§)	kN	203	201	193	190
	lbf	45,829	45,315	43,399	42,894
Operating Weight*	kg	31 086	31 224	31 196	31 334
	lb	68,513	68,817	68,755	69,060

* Static tipping loads and operating weights shown are based on a machine configuration with Bridgestone 29.5R25 VSNT L4 radial tires, full fluids, operator, counterweight, ride control, cold start, roading fenders, power train guard, secondary steering and sound suppression.

† Illustration shown with Dimension charts.

*** Rock bucket specifications are given on Bridgestone 29.5R25 VSDT L5 Radial tires.

(§) Measured 102 mm (4") behind tip of cutting edge with bucket hinge pin as pivot point in accordance with SAE J732C.

(§) Specifications and ratings conform to all applicable standards recommended by the Society of Automotive Engineers, including SAE Standard J732C governing loader ratings.

(ISO) Full compliance to ISO 14397-1:2007 Sections 1 thru 6, which requires 2% verification between calculations and testing.

(Rigid Tire) Compliance to ISO 14397-1:2007 Sections 1 thru 5.

Other buckets are available and offerings vary by region. Consult your local Cat dealer for further details.

980 Wheel Loader Specifications

Operating Specifications – Buckets (continued)

Linkage		High Lift Linkage			
Bucket Type		General Purpose – Pin On			
Edge Type		Bolt-On Cutting Edges	Teeth and Segments	Bolt-On Cutting Edges	Teeth and Segments
Capacity – Rated	m ³	5.40	5.40	5.70	5.70
	yd ³	7.00	7.00	7.50	7.50
Capacity – Rated at 110% Fill Factor	m ³	5.90	5.90	6.30	6.30
	yd ³	7.75	7.75	8.25	8.25
Width	mm	3447	3535	3447	3535
	ft/in	11'3"	11'7"	11'3"	11'7"
16 † Dump Clearance at Maximum Lift and 45° Discharge	mm	3508	3342	3439	3272
	ft/in	11'6"	10'11"	11'3"	10'8"
17 † Reach at Maximum Lift and 45° Discharge	mm	1484	1621	1532	1667
	ft/in	4'10"	5'3"	5'0"	5'5"
Reach at Level Lift Arm and Bucket Level	mm	3126	3337	3210	3421
	ft/in	10'3"	10'11"	10'6"	11'2"
A † Digging Depth	mm	86	86	86	86
	in	3.4"	3.4"	3.4"	3.4"
12 † Overall Length	mm	9875	10 114	9959	10 198
	ft/in	32'5"	33'3"	32'9"	33'6"
B † Overall Height with Bucket at Maximum Lift	mm	6656	6656	6478	6478
	ft/in	21'11"	21'11"	21'4"	21'4"
Loader Clearance Circle Radius with Bucket at Carry Position	mm	8114	8226	8137	8250
	ft/in	26'8"	27'0"	26'9"	27'1"
Static Tipping Load, Straight (ISO)*	kg	20 833	20 650	20 603	20 419
	lb	45,917	45,513	45,410	45,004
Static Tipping Load, Straight (Rigid Tire)*	kg	22 033	21 849	21 805	21 619
	lb	48,562	48,156	48,058	47,649
Static Tipping Load, Articulated (ISO)*	kg	18 354	18 171	18 137	17 953
	lb	40,453	40,049	39,975	39,569
Static Tipping Load, Articulated (Rigid Tire)*	kg	19 430	19 245	19 215	19 029
	lb	42,823	42,416	42,351	41,941
Breakout Force (§)	kN	230	228	217	215
	lbf	51,775	51,273	48,860	48,369
Operating Weight*	kg	30 477	30 616	30 560	30 699
	lb	67,171	67,476	67,354	67,659

* Static tipping loads and operating weights shown are based on a machine configuration with Bridgestone 29.5R25 VSNT L4 radial tires, full fluids, operator, counterweight, ride control, cold start, roading fenders, power train guard, secondary steering and sound suppression.

† Illustration shown with Dimension charts.

*** Rock bucket specifications are given on Bridgestone 29.5R25 VSDT L5 Radial tires.

(§) Measured 102 mm (4") behind tip of cutting edge with bucket hinge pin as pivot point in accordance with SAE J732C.

(§) Specifications and ratings conform to all applicable standards recommended by the Society of Automotive Engineers, including SAE Standard J732C governing loader ratings.

(ISO) Full compliance to ISO 14397-1:2007 Sections 1 thru 6, which requires 2% verification between calculations and testing.

(Rigid Tire) Compliance to ISO 14397-1:2007 Sections 1 thru 5.

Other buckets are available and offerings vary by region. Consult your local Cat dealer for further details.

980 Wheel Loader Specifications

Operating Specifications – Buckets (continued)

Linkage		High Lift Linkage			
Bucket Type		General Purpose – Pin On			
Edge Type		Bolt-On Cutting Edges	Teeth and Segments	Bolt-On Cutting Edges	Teeth and Segments
Capacity – Rated	m ³	6.00	6.00	6.40	6.40
	yd ³	7.75	7.75	8.25	8.25
Capacity – Rated at 110% Fill Factor	m ³	6.60	6.60	7.00	7.00
	yd ³	8.75	8.75	9.25	9.25
Width	mm	3447	3535	3447	3535
	ft/in	11'3"	11'7"	11'3"	11'7"
16 † Dump Clearance at Maximum Lift and 45° Discharge	mm	3421	3254	3366	3198
	ft/in	11'2"	10'8"	11'0"	10'5"
17 † Reach at Maximum Lift and 45° Discharge	mm	1554	1688	1606	1740
	ft/in	5'1"	5'6"	5'3"	5'8"
Reach at Level Lift Arm and Bucket Level	mm	3238	3449	3315	3526
	ft/in	10'7"	11'3"	10'10"	11'6"
A † Digging Depth	mm	86	86	86	86
	in	3.4"	3.4"	3.4"	3.4"
12 † Overall Length	mm	9987	10 226	10 064	10 303
	ft/in	32'10"	33'7"	33'1"	33'10"
B † Overall Height with Bucket at Maximum Lift	mm	6504	6504	6824	6824
	ft/in	21'5"	21'5"	22'5"	22'5"
Loader Clearance Circle Radius with Bucket at Carry Position	mm	8144	8258	8166	8279
	ft/in	26'9"	27'2"	26'10"	27'2"
Static Tipping Load, Straight (ISO)*	kg	20 466	20 282	20 302	20 117
	lb	45,108	44,702	44,747	44,338
Static Tipping Load, Straight (Rigid Tire)*	kg	21 669	21 483	21 512	21 324
	lb	47,760	47,350	47,413	47,000
Static Tipping Load, Articulated (ISO)*	kg	18 004	17 820	17 850	17 664
	lb	39,682	39,275	39,342	38,932
Static Tipping Load, Articulated (Rigid Tire)*	kg	19 084	18 898	18 937	18 749
	lb	42,062	41,651	41,737	41,323
Breakout Force (§)	kN	213	211	202	200
	lbf	47,897	47,409	45,564	45,084
Operating Weight*	kg	30 656	30 795	30 718	30 857
	lb	67,566	67,871	67,703	68,007

* Static tipping loads and operating weights shown are based on a machine configuration with Bridgestone 29.5R25 VSNT L4 radial tires, full fluids, operator, counterweight, ride control, cold start, roading fenders, power train guard, secondary steering and sound suppression.

† Illustration shown with Dimension charts.

*** Rock bucket specifications are given on Bridgestone 29.5R25 VSDT L5 Radial tires.

(§) Measured 102 mm (4") behind tip of cutting edge with bucket hinge pin as pivot point in accordance with SAE J732C.

(§) Specifications and ratings conform to all applicable standards recommended by the Society of Automotive Engineers, including SAE Standard J732C governing loader ratings.

(ISO) Full compliance to ISO 14397-1:2007 Sections 1 thru 6, which requires 2% verification between calculations and testing.

(Rigid Tire) Compliance to ISO 14397-1:2007 Sections 1 thru 5.

Other buckets are available and offerings vary by region. Consult your local Cat dealer for further details.

980 Wheel Loader Specifications

Operating Specifications – Buckets (continued)

Linkage		High Lift Linkage			
Bucket Type		General Purpose – Pin On – Abrasion			
Edge Type		Bolt-On Cutting Edges	Teeth and Segments	Bolt-On Cutting Edges	Teeth and Segments
Capacity – Rated	m ³	5.70	5.70	6.00	6.00
	yd ³	7.50	7.50	7.75	7.75
Capacity – Rated at 110% Fill Factor	m ³	6.30	6.30	6.60	6.60
	yd ³	8.25	8.25	8.75	8.75
Width	mm	3447	3535	3447	3546
	ft/in	11'3"	11'7"	11'3"	11'7"
16† Dump Clearance at Maximum Lift and 45° Discharge	mm	3439	3272	3422	3258
	ft/in	11'3"	10'8"	11'2"	10'8"
17† Reach at Maximum Lift and 45° Discharge	mm	1532	1667	1553	1688
	ft/in	5'0"	5'5"	5'1"	5'6"
Reach at Level Lift Arm and Bucket Level	mm	3210	3421	3237	3446
	ft/in	10'6"	11'2"	10'7"	11'3"
A† Digging Depth	mm	86	86	86	86
	in	3.4"	3.4"	3.4"	3.4"
12† Overall Length	mm	9959	10 198	9986	10 221
	ft/in	32'9"	33'6"	32'10"	33'7"
B† Overall Height with Bucket at Maximum Lift	mm	6478	6478	6744	6744
	ft/in	21'4"	21'4"	22'2"	22'2"
Loader Clearance Circle Radius with Bucket at Carry Position	mm	8137	8250	8144	8261
	ft/in	26'9"	27'1"	26'9"	27' 2"
Static Tipping Load, Straight (ISO)*	kg	20 445	20 261	20 403	20 245
	lb	45,062	44,656	44,968	44,621
Static Tipping Load, Straight (Rigid Tire)*	kg	21 645	21 459	21 598	21 439
	lb	47,706	47,296	47,604	47,253
Static Tipping Load, Articulated (ISO)*	kg	17 980	17 795	17 949	17 791
	lb	39,628	39,222	39,560	39,212
Static Tipping Load, Articulated (Rigid Tire)*	kg	19 055	18 870	19 022	18 862
	lb	41,999	41,589	41,924	41,573
Breakout Force (§)	kN	216	214	213	211
	lbf	48,733	48,241	47,914	47,479
Operating Weight*	kg	30 707	30 845	30 655	30 773
	lb	67,677	67,981	67,563	67,822

* Static tipping loads and operating weights shown are based on a machine configuration with Bridgestone 29.5R25 VSNT L4 radial tires, full fluids, operator, counterweight, ride control, cold start, roading fenders, power train guard, secondary steering and sound suppression.

† Illustration shown with Dimension charts.

*** Rock bucket specifications are given on Bridgestone 29.5R25 VSDT L5 Radial tires.

(§) Measured 102 mm (4") behind tip of cutting edge with bucket hinge pin as pivot point in accordance with SAE J732C.

(§) Specifications and ratings conform to all applicable standards recommended by the Society of Automotive Engineers, including SAE Standard J732C governing loader ratings.

(ISO) Full compliance to ISO 14397-1:2007 Sections 1 thru 6, which requires 2% verification between calculations and testing.

(Rigid Tire) Compliance to ISO 14397-1:2007 Sections 1 thru 5.

Other buckets are available and offerings vary by region. Consult your local Cat dealer for further details.

980 Wheel Loader Specifications

Operating Specifications – Buckets *(continued)*

Linkage		High Lift Linkage		
Bucket Type		Flat Floor – Pin On		Flat Floor – Pin On – Light Material (Coal)
Edge Type		Bolt-On Cutting Edges	Teeth and Segments	Bolt-On Cutting Edges
Capacity – Rated	m ³	5.70	5.70	8.40
	yd ³	7.50	7.50	11.00
Capacity – Rated at 110% Fill Factor	m ³	6.30	6.30	9.20
	yd ³	8.25	8.25	12.00
Width	mm	3447	3535	3638
	ft/in	11'3"	11'7"	11'11"
16 † Dump Clearance at Maximum Lift and 45° Discharge	mm	3340	3163	3156
	ft/in	10'11"	10'4"	10'4"
17 † Reach at Maximum Lift and 45° Discharge	mm	1447	1569	1631
	ft/in	4'8"	5'1"	5'4"
Reach at Level Lift Arm and Bucket Level	mm	3235	3446	3495
	ft/in	10'7"	11'3"	11'5"
A † Digging Depth	mm	86	86	88
	in	3.4"	3.4"	3.4"
12 † Overall Length	mm	9984	10 223	10 244
	ft/in	32'10"	33'7"	33'8"
B † Overall Height with Bucket at Maximum Lift	mm	6477	6477	7001
	ft/in	21'3"	21'3"	23'0"
Loader Clearance Circle Radius with Bucket at Carry Position	mm	8143	8257	8303
	ft/in	26'9"	27'2"	27'3"
Static Tipping Load, Straight (ISO)*	kg	20 155	19 973	19 951
	lb	44,423	44,022	43,985
Static Tipping Load, Straight (Rigid Tire)*	kg	21 323	21 140	21 198
	lb	46,996	46,592	46,735
Static Tipping Load, Articulated (ISO)*	kg	17 730	17 548	17 498
	lb	39,077	38,677	38,578
Static Tipping Load, Articulated (Rigid Tire)*	kg	18 777	18 594	18 623
	lb	41,386	40,982	41,057
Breakout Force (§)	kN	213	211	181
	lbf	48,005	47,516	40,689
Operating Weight*	kg	30 685	30 824	30 984
	lb	67,630	67,935	68,307

*Static tipping loads and operating weights shown are based on a machine configuration with Bridgestone 29.5R25 VSNT L4 radial tires, full fluids, operator, counterweight, ride control, cold start, roading fenders, power train guard, secondary steering and sound suppression.

† Illustration shown with Dimension charts.

***Rock bucket specifications are given on Bridgestone 29.5R25 VSDT L5 Radial tires.

(§) Measured 102 mm (4") behind tip of cutting edge with bucket hinge pin as pivot point in accordance with SAE J732C.

(§) Specifications and ratings conform to all applicable standards recommended by the Society of Automotive Engineers, including SAE Standard J732C governing loader ratings.

(ISO) Full compliance to ISO 14397-1:2007 Sections 1 thru 6, which requires 2% verification between calculations and testing.

(Rigid Tire) Compliance to ISO 14397-1:2007 Sections 1 thru 5.

Other buckets are available and offerings vary by region. Consult your local Cat dealer for further details.

980 Wheel Loader Specifications

Operating Specifications – Buckets (continued)

Linkage		High Lift Linkage	
Bucket Type		Rock, Spade*** – Pin On	
Edge Type		Teeth and Segments	Teeth and Segments
Capacity – Rated	m ³	4.40	4.50
	yd ³	5.75	6.00
Capacity – Rated at 110% Fill Factor	m ³	4.80	5.00
	yd ³	6.25	6.50
Width	mm	3524	3524
	ft/in	11'6"	11'6"
16† Dump Clearance at Maximum Lift and 45° Discharge	mm	3355	3355
	ft/in	11'0"	11'0"
17† Reach at Maximum Lift and 45° Discharge	mm	1771	1771
	ft/in	5'9"	5'9"
Reach at Level Lift Arm and Bucket Level	mm	3438	3438
	ft/in	11'3"	11'3"
A† Digging Depth	mm	81	81
	in	3.2"	3.2"
12† Overall Length	mm	10 192	10 192
	ft/in	33'6"	33'6"
B† Overall Height with Bucket at Maximum Lift	mm	6422	6429
	ft/in	21'1"	21'2"
Loader Clearance Circle Radius with Bucket at Carry Position	mm	8239	8239
	ft/in	27'1"	27'1"
Static Tipping Load, Straight (ISO)*	kg	21 403	21 035
	lb	47,172	46,375
Static Tipping Load, Straight (Rigid Tire)*	kg	22 626	22 266
	lb	49,867	49,089
Static Tipping Load, Articulated (ISO)*	kg	18 844	18 472
	lb	41,533	40,725
Static Tipping Load, Articulated (Rigid Tire)*	kg	19 938	19 574
	lb	43,944	43,154
Breakout Force (§)	kN	216	214
	lbf	48,615	48,291
Operating Weight*	kg	31 164	31 588
	lb	68,685	69,639

* Static tipping loads and operating weights shown are based on a machine configuration with Bridgestone 29.5R25 VSNT L4 radial tires, full fluids, operator, counterweight, ride control, cold start, roading fenders, power train guard, secondary steering and sound suppression.

† Illustration shown with Dimension charts.

*** Rock bucket specifications are given on Bridgestone 29.5R25 VSDT L5 Radial tires.

(§) Measured 102 mm (4") behind tip of cutting edge with bucket hinge pin as pivot point in accordance with SAE J732C.

(§) Specifications and ratings conform to all applicable standards recommended by the Society of Automotive Engineers, including SAE Standard J732C governing loader ratings.

(ISO) Full compliance to ISO 14397-1:2007 Sections 1 thru 6, which requires 2% verification between calculations and testing.

(Rigid Tire) Compliance to ISO 14397-1:2007 Sections 1 thru 5.

Other buckets are available and offerings vary by region. Consult your local Cat dealer for further details.

980 Wheel Loader Specifications

Operating Specifications – Buckets *(continued)*

Linkage		High Lift Linkage			
Bucket Type		General Purpose – Hook On – Fusion			
Edge Type		Bolt-On Cutting Edges	Teeth and Segments	Bolt-On Cutting Edges	Teeth and Segments
Capacity – Rated	m ³	5.40	5.40	5.70	5.70
	yd ³	7.00	7.00	7.50	7.50
Capacity – Rated at 110% Fill Factor	m ³	5.90	5.90	6.30	6.30
	yd ³	7.75	7.75	8.25	8.25
Width	mm	3447	3535	3481	3546
	ft/in	11'3"	11'7"	11'5"	11'7"
16 † Dump Clearance at Maximum Lift and 45° Discharge	mm	3403	3237	3339	3175
	ft/in	11'2"	10'7"	10'11"	10'5"
17 † Reach at Maximum Lift and 45° Discharge	mm	1591	1727	1641	1776
	ft/in	5'2"	5'8"	5'4"	5'9"
Reach at Level Lift Arm and Bucket Level	mm	3276	3487	3358	3567
	ft/in	10'8"	11'5"	11'0"	11'8"
A † Digging Depth	mm	91	91	91	91
	in	3.6"	3.6"	3.6"	3.6"
12 † Overall Length	mm	10 028	10 268	10 110	10 345
	ft/in	32'11"	33'9"	33'3"	34'0"
B † Overall Height with Bucket at Maximum Lift	mm	6752	6752	6820	6820
	ft/in	22'2"	22'2"	22'5"	22'5"
Loader Clearance Circle Radius with Bucket at Carry Position	mm	8199	8321	8240	8351
	ft/in	26'11"	27'4"	27'1"	27'5"
Static Tipping Load, Straight (ISO)*	kg	19 474	19 292	19 237	19 081
	lb	42,920	42,521	42,400	42,054
Static Tipping Load, Straight (Rigid Tire)*	kg	20 638	20 455	20 406	20 248
	lb	45,488	45,084	44,975	44,626
Static Tipping Load, Articulated (ISO)*	kg	17 068	16 887	16 842	16 685
	lb	37,619	37,219	37,121	36,775
Static Tipping Load, Articulated (Rigid Tire)*	kg	18 114	17 931	17 892	17 734
	lb	39,923	39,520	39,435	39,086
Breakout Force (§)	kN	207	204	196	194
	lbf	46,533	46,045	44,095	43,669
Operating Weight*	kg	31 219	31 358	31 342	31 460
	lb	68,807	69,112	69,077	69,336

* Static tipping loads and operating weights shown are based on a machine configuration with Bridgestone 29.5R25 VSNT L4 radial tires, full fluids, operator, counterweight, ride control, cold start, roading fenders, power train guard, secondary steering and sound suppression.

† Illustration shown with Dimension charts.

*** Rock bucket specifications are given on Bridgestone 29.5R25 VSDT L5 Radial tires.

(§) Measured 102 mm (4") behind tip of cutting edge with bucket hinge pin as pivot point in accordance with SAE J732C.

(§) Specifications and ratings conform to all applicable standards recommended by the Society of Automotive Engineers, including SAE Standard J732C governing loader ratings.

(ISO) Full compliance to ISO 14397-1:2007 Sections 1 thru 6, which requires 2% verification between calculations and testing.

(Rigid Tire) Compliance to ISO 14397-1:2007 Sections 1 thru 5.

Other buckets are available and offerings vary by region. Consult your local Cat dealer for further details.

980 Wheel Loader Specifications

Operating Specifications – Buckets *(continued)*

Linkage		Aggregate Handler Linkage			
Bucket Type		General Purpose – Pin On			
Edge Type		Bolt-On Cutting Edges	Teeth and Segments	Bolt-On Cutting Edges	Teeth and Segments
Capacity – Rated	m ³	5.40	5.40	5.70	5.70
	yd ³	7.00	7.00	7.50	7.50
Capacity – Rated at 110% Fill Factor	m ³	5.90	5.90	6.30	6.30
	yd ³	7.75	7.75	8.25	8.25
Width	mm	3447	3535	3447	3535
	ft/in	11'3"	11'7"	11'3"	11'7"
16 † Dump Clearance at Maximum Lift and 45° Discharge	mm	3287	3121	3219	3051
	ft/in	10'9"	10'2"	10'6"	10'0"
17 † Reach at Maximum Lift and 45° Discharge	mm	1481	1618	1529	1664
	ft/in	4'10"	5'3"	5'0"	5'5"
Reach at Level Lift Arm and Bucket Level	mm	2966	3177	3050	3261
	ft/in	9'8"	10'5"	10'0"	10'8"
A † Digging Depth	mm	88	88	88	88
	in	3.4"	3.4"	3.4"	3.4"
12 † Overall Length	mm	9677	9919	9761	10 003
	ft/in	31'9"	32'7"	32'1"	32'10"
B † Overall Height with Bucket at Maximum Lift	mm	6435	6435	6258	6258
	ft/in	21'2"	21'2"	20'7"	20'7"
Loader Clearance Circle Radius with Bucket at Carry Position	mm	7612	7725	7635	7749
	ft/in	25'0"	25'5"	25'1"	25'6"
Static Tipping Load, Straight (ISO)*	kg	24 404	24 218	24 149	23 963
	lb	53,786	53,377	53,226	52,814
Static Tipping Load, Straight (Rigid Tire)*	kg	25 939	25 752	25 687	25 498
	lb	57,171	56,758	56,615	56,199
Static Tipping Load, Articulated (ISO)*	kg	21 012	20 826	20 776	20 589
	lb	46,312	45,902	45,792	45,380
Static Tipping Load, Articulated (Rigid Tire)*	kg	22 406	22 218	22 173	21 984
	lb	49,383	48,969	48,870	48,454
Breakout Force (§)	kN	227	224	214	211
	lbf	51,008	50,477	48,132	47,613
Operating Weight*	kg	30 985	31 123	31 068	31 206
	lb	68,290	68,595	68,473	68,778

*Static tipping loads and operating weights shown are based on a machine configuration with Bridgestone 29.5R25 VSNT L4 radial tires, full fluids, operator, counterweight, ride control, cold start, roading fenders, power train guard, secondary steering and sound suppression.

** Aggregate Handler configuration is not compatible with rock buckets, and high lift.

† Illustration shown with Dimension charts.

(§) Measured 102 mm (4") behind tip of cutting edge with bucket hinge pin as pivot point in accordance with SAE J732C.

(§) Specifications and ratings conform to all applicable standards recommended by the Society of Automotive Engineers, including SAE Standard J732C governing loader ratings.

(ISO) Full compliance to ISO 14397-1:2007 Sections 1 thru 6, which requires 2% verification between calculations and testing.

(Rigid Tire) Compliance to ISO 14397-1:2007 Sections 1 thru 5.

Other buckets are available and offerings vary by region. Consult your local Cat dealer for further details.

980 Wheel Loader Specifications

Operating Specifications – Buckets *(continued)*

Linkage		Aggregate Handler Linkage			
Bucket Type		General Purpose – Pin On			
Edge Type		Bolt-On Cutting Edges	Teeth and Segments	Bolt-On Cutting Edges	Teeth and Segments
Capacity – Rated	m ³	6.00	6.00	6.40	6.40
	yd ³	7.75	7.75	8.25	8.25
Capacity – Rated at 110% Fill Factor	m ³	6.60	6.60	7.00	7.00
	yd ³	8.75	8.75	9.25	9.25
Width	mm	3447	3535	3447	3535
	ft/in	11'3"	11'7"	11'3"	11'7"
16 † Dump Clearance at Maximum Lift and 45° Discharge	mm	3201	3034	3145	2977
	ft/in	10'6"	9'11"	10'3"	9'9"
17 † Reach at Maximum Lift and 45° Discharge	mm	1551	1686	1603	1737
	ft/in	5'1"	5'6"	5'3"	5'8"
Reach at Level Lift Arm and Bucket Level	mm	3078	3289	3155	3366
	ft/in	10'1"	10'9"	10'4"	11'0"
A † Digging Depth	mm	88	88	88	88
	in	3.4"	3.4"	3.4"	3.4"
12 † Overall Length	mm	9789	10 031	9866	10 108
	ft/in	32'2"	32'11"	32'5"	33'2"
B † Overall Height with Bucket at Maximum Lift	mm	6284	6284	6604	6604
	ft/in	20'8"	20'8"	21'8"	21'8"
Loader Clearance Circle Radius with Bucket at Carry Position	mm	7643	7757	7664	7779
	ft/in	25'1"	25'6"	25'2"	25'7"
Static Tipping Load, Straight (ISO)*	kg	24 006	23 819	23 828	23 639
	lb	52,910	52,498	52,517	52,102
Static Tipping Load, Straight (Rigid Tire)*	kg	25 547	25 357	25 377	25 186
	lb	56,305	55,888	55,932	55,512
Static Tipping Load, Articulated (ISO)*	kg	20 638	20 451	20 472	20 283
	lb	45,488	45,074	45,121	44,705
Static Tipping Load, Articulated (Rigid Tire)*	kg	22 038	21 849	21 882	21 691
	lb	48,572	48,155	48,228	47,807
Breakout Force (§)	kN	210	207	199	197
	lbf	47,182	46,666	44,880	44,374
Operating Weight*	kg	31 164	31 302	31 226	31 364
	lb	68,685	68,990	68,822	69,126

* Static tipping loads and operating weights shown are based on a machine configuration with Bridgestone 29.5R25 VSNT L4 radial tires, full fluids, operator, counterweight, ride control, cold start, roading fenders, power train guard, secondary steering and sound suppression.

** Aggregate Handler configuration is not compatible with rock buckets, and high lift.

† Illustration shown with Dimension charts.

(§) Measured 102 mm (4") behind tip of cutting edge with bucket hinge pin as pivot point in accordance with SAE J732C.

(§) Specifications and ratings conform to all applicable standards recommended by the Society of Automotive Engineers, including SAE Standard J732C governing loader ratings.

(ISO) Full compliance to ISO 14397-1:2007 Sections 1 thru 6, which requires 2% verification between calculations and testing.

(Rigid Tire) Compliance to ISO 14397-1:2007 Sections 1 thru 5.

Other buckets are available and offerings vary by region. Consult your local Cat dealer for further details.

980 Wheel Loader Specifications

Operating Specifications – Buckets (continued)

Linkage		Aggregate Handler Linkage		
Bucket Type		Flat Floor – Pin On		Flat Floor – Pin On – Light Material (Coal)
Edge Type		Bolt-On Cutting Edges	Teeth and Segments	Bolt-On Cutting Edges
Capacity – Rated	m ³	5.70	5.70	8.40
	yd ³	7.50	7.50	11.00
Capacity – Rated at 110% Fill Factor	m ³	6.30	6.30	9.20
	yd ³	8.25	8.25	12.00
Width	mm	3447	3535	3638
	ft/in	11'3"	11'7"	11'11"
16 † Dump Clearance at Maximum Lift and 45° Discharge	mm	3120	2943	2936
	ft/in	10'2"	9'7"	9'7"
17 † Reach at Maximum Lift and 45° Discharge	mm	1444	1566	1628
	ft/in	4'8"	5'1"	5'4"
Reach at Level Lift Arm and Bucket Level	mm	3075	3286	3335
	ft/in	10'1"	10'9"	10'11"
A † Digging Depth	mm	88	88	88
	in	3.4"	3.4"	3.4"
12 † Overall Length	mm	9786	10 028	10 046
	ft/in	32'2"	32'11"	33'0"
B † Overall Height with Bucket at Maximum Lift	mm	6257	6257	6781
	ft/in	20'7"	20'7"	22'3"
Loader Clearance Circle Radius with Bucket at Carry Position	mm	7642	7756	7802
	ft/in	25'1"	25'6"	25'8"
Static Tipping Load, Straight (ISO)*	kg	23 621	23 437	23 486
	lb	52,061	51,655	51 778
Static Tipping Load, Straight (Rigid Tire)*	kg	25 111	24 925	25 090
	lb	55,346	54,936	55,314
Static Tipping Load, Articulated (ISO)*	kg	20 307	20 122	20 127
	lb	44,757	44,350	44,373
Static Tipping Load, Articulated (Rigid Tire)*	kg	21 661	21 475	21 590
	lb	47,741	47,330	47,599
Breakout Force (§)	kN	210	208	178
	lbf	47,288	46,772	40 069
Operating Weight*	kg	31 193	31 331	31 492
	lb	68,749	69,054	69,427

*Static tipping loads and operating weights shown are based on a machine configuration with Bridgestone 29.5R25 VSNT L4 radial tires, full fluids, operator, counterweight, ride control, cold start, roading fenders, power train guard, secondary steering and sound suppression.

** Aggregate Handler configuration is not compatible with rock buckets, and high lift.

† Illustration shown with Dimension charts.

(§) Measured 102 mm (4") behind tip of cutting edge with bucket hinge pin as pivot point in accordance with SAE J732C.

(§) Specifications and ratings conform to all applicable standards recommended by the Society of Automotive Engineers, including SAE Standard J732C governing loader ratings.

(ISO) Full compliance to ISO 14397-1:2007 Sections 1 thru 6, which requires 2% verification between calculations and testing.

(Rigid Tire) Compliance to ISO 14397-1:2007 Sections 1 thru 5.

Other buckets are available and offerings vary by region. Consult your local Cat dealer for further details.

980 Wheel Loader Specifications

Operating Specifications – Buckets *(continued)*

Linkage		Aggregate Handler Linkage			
Bucket Type		General Purpose – Hook On – Fusion			
Edge Type		Bolt-On Cutting Edges	Teeth and Segments	Bolt-On Cutting Edges	Teeth and Segments
Capacity – Rated	m ³	5.40	5.40	5.70	5.70
	yd ³	7.00	7.00	7.50	7.50
Capacity – Rated at 110% Fill Factor	m ³	5.90	5.90	6.30	6.30
	yd ³	7.75	7.75	8.25	8.25
Width	mm	3447	3535	3447	3535
	ft/in	11'3"	11'7"	11'3"	11'7"
16 † Dump Clearance at Maximum Lift and 45° Discharge	mm	3183	3017	3117	2950
	ft/in	10'5"	9'10"	10'2"	9'8"
17 † Reach at Maximum Lift and 45° Discharge	mm	1588	1724	1640	1775
	ft/in	5'2"	5'7"	5'4"	5'9"
Reach at Level Lift Arm and Bucket Level	mm	3116	3327	3200	3411
	ft/in	10'2"	10'11"	10'6"	11'2"
A † Digging Depth	mm	93	93	93	93
	in	3.6"	3.6"	3.6"	3.6"
12 † Overall Length	mm	9831	10 072	9915	10 156
	ft/in	32'4"	33'1"	32'7"	33'4"
B † Overall Height with Bucket at Maximum Lift	mm	6532	6532	6599	6599
	ft/in	21'6"	21'6"	21'8"	21'8"
Loader Clearance Circle Radius with Bucket at Carry Position	mm	7694	7817	7721	7845
	ft/in	25'3"	25'8"	25'4"	25'9"
Static Tipping Load, Straight (ISO)*	kg	22 905	22 721	22 672	22 487
	lb	50,483	50,078	49,970	49,561
Static Tipping Load, Straight (Rigid Tire)*	kg	24 393	24 207	24 170	23 983
	lb	53,763	53,353	53,271	52,858
Static Tipping Load, Articulated (ISO)*	kg	19 618	19 434	19 398	19 212
	lb	43,239	42,833	42,753	42,344
Static Tipping Load, Articulated (Rigid Tire)*	kg	20 971	20 785	20 762	20 574
	lb	46,221	45,812	45,759	45,346
Breakout Force (§)	kN	203	201	193	190
	lbf	45,829	45,315	43,399	42,894
Operating Weight*	kg	31 727	31 865	31 837	31 975
	lb	69,926	70,231	70,168	70,473

* Static tipping loads and operating weights shown are based on a machine configuration with Bridgestone 29.5R25 VSNT L4 radial tires, full fluids, operator, counterweight, ride control, cold start, roading fenders, power train guard, secondary steering and sound suppression.

** Aggregate Handler configuration is not compatible with rock buckets, and high lift.

† Illustration shown with Dimension charts.

(§) Measured 102 mm (4") behind tip of cutting edge with bucket hinge pin as pivot point in accordance with SAE J732C.

(§) Specifications and ratings conform to all applicable standards recommended by the Society of Automotive Engineers, including SAE Standard J732C governing loader ratings.

(ISO) Full compliance to ISO 14397-1:2007 Sections 1 thru 6, which requires 2% verification between calculations and testing.

(Rigid Tire) Compliance to ISO 14397-1:2007 Sections 1 thru 5.

Other buckets are available and offerings vary by region. Consult your local Cat dealer for further details.

980 Wheel Loader Specifications

Fork Specifications

Fork Specifications

1	Tine Length	mm	1830
		in	72.0
2	Load Center	mm	915
		in	36.0
	Static Tipping Load - Straight (Forks Level)	kg	15570
		lbs	34316
	Static Tipping Load - Articulated (Forks Level)	kg	13586
		lbs	29943
	Rated Load (SAE J1197 - 50% FTSTL)	kg	6793
		lbs	14971
	Rated Load (CEN EN 474-3 Rough Terrain - 60% FTSTL)	kg	8151
		lbs	17966
	Rated Load (CEN EN 474-3 Firm and Level Ground - 80% FTSTL)	kg	8327
		lbs	18352
3	Maximum Overall Length	mm	10442
		in	411.1
4	Reach with Forks at Ground Level	mm	1199
		in	47.2
5	*Ground to Bottom of Tine at Minimum Height and Fork Level	mm	-151
		in	-5.9
6	Reach with Arms Horizontal and Forks Level	mm	1809
		in	71.2
7	Reach with Fork at Maximum Height	mm	883
		in	34.7
8	Ground to Top of Tine with Arms Horizontal and Fork Level	mm	2024
		in	79.7
9	Ground to Top of Tine at Maximum Height and Fork Level	mm	4292
		in	169.0
10	Overall Height of Fork at Full Lift (top of carriage to ground)	mm	5067
		in	199.5
11	Clearance at Full Lift and Max Dump	mm	2676
		in	105.4
12	Max Discharge Angle from Horizontal	deg	45
13	Overall Carriage Width	mm	2217
		in	87.3
14	Overall Carriage Height	mm	840
		in	33.1
15	Outside Tine Width (max spread)	mm	2070
		in	81.5
16	Outside Tine Width (min spread)	mm	470
		in	18.5
	Tine Width (single tine)	mm	150.0
		in	5.9
	Tine Thickness	mm	65.0
		in	2.6
	Tine Capacity	kg	5246
		lbs	11562
	Operating Weight	kg	29081
		lbs	64093

*Negative values indicate below grade

980 STD Pallet Fork, FUSION

87" Carriage 72" Tine
530-1861 530-1869

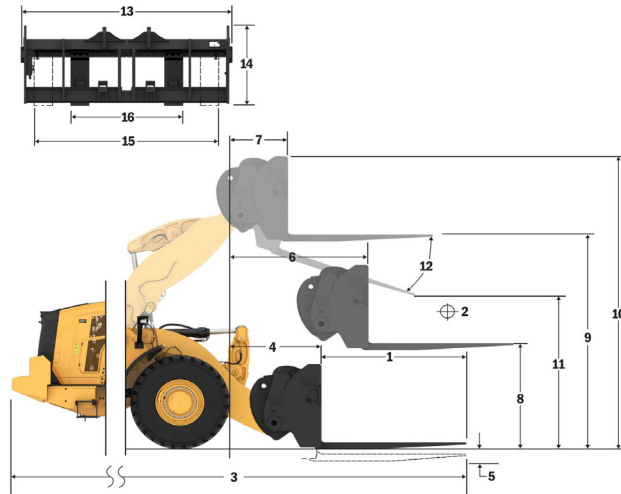

Capacity (kg)
(Calculated Load at CG Point)

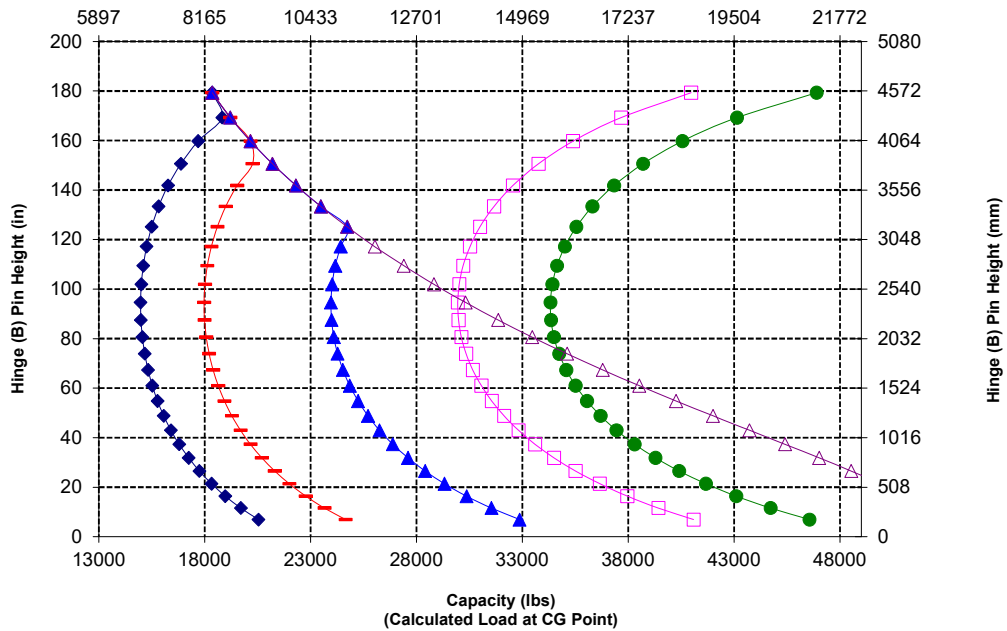

NOTE: Static tipping loads and operating weight are based on the following loader configuration: Bridgestone *VSNT L4 Tires, Air Conditioning, Ride Control, Powertrain Guard, Full Fluids, Fuel Tank, Coolant, Lubricants, and Operator.

Specifications and ratings conform to the following standards: SAE* J1197, ISO 14397-1, CEN** EN 474-3.

The rated operating load for a loader equipped with a pallet fork is determined by:
SAE J1197: 50% of full turn static tipping load or hydraulic limit.
CEN EN 474-3: 60% of full turn static tipping load on rough terrain or hydraulic limit.
CEN EN 474-3: 80% of full turn static tipping load on firm and level ground or hydraulic limit.

*SAE - Society of Automotive Engineers
**CEN - European Committee for Standardization



WARNING: Do not exceed tine load capacity. Individual tine capacity is stamped on the side of each tine.

980 Wheel Loader Specifications

Fork Specifications

Fork Specifications

1	Tine Length	mm	1829
		in	72.0
2	Load Center	mm	915
		in	36.0
	Static Tipping Load - Straight (Forks Level)	kq	15292
		lbs	33703
	Static Tipping Load - Articulated (Forks Level)	kq	13299
		lbs	29312
	Rated Load (SAE J1197 - 50% FTSTL)	kq	6650
		lbs	14656
	Rated Load (CEN EN 474-3 Rough Terrain - 60% FTSTL)	kq	7980
		lbs	17587
	Rated Load (CEN EN 474-3 Firm and Level Ground - 80% FTSTL)	kq	8691
		lbs	19155
3	Maximum Overall Length	mm	10383
		in	408.8
4	Reach with Forks at Ground Level	mm	1141
		in	44.9
5	*Ground to Bottom of Tine at Minimum Height and Fork Level	mm	-65
		in	-2.5
6	Reach with Arms Horizontal and Forks Level	mm	1797
		in	70.7
7	Reach with Fork at Maximum Height	mm	870
		in	34.2
8	Ground to Top of Tine with Arms Horizontal and Fork Level	mm	2135
		in	84.0
9	Ground to Top of Tine at Maximum Height and Fork Level	mm	4403
		in	173.4
10	Overall Height of Fork at Full Lift (top of carriage to ground)	mm	5443
		in	214.3
11	Clearance at Full Lift and Max Dump	mm	2597
		in	102.3
12	Max Discharge Angle from Horizontal	deg	51
13	Overall Carriage Width	mm	2833
		in	111.5
14	Overall Carriage Height	mm	1130
		in	44.5
15	Outside Tine Width (max spread)	mm	2483
		in	97.8
16	Outside Tine Width (min spread)	mm	590
		in	23.2
	Tine Width (single tine)	mm	180.0
		in	7.1
	Tine Thickness	mm	90.0
		in	3.5
	Tine Capacity	kq	14800
		lbs	32619
	Operating Weight	kq	29520
		lbs	65061

*Negative values indicate below grade

980 STD

Construction Fork, FUSION

108" Carriage

72" Tine

520-7968

520-7979

*Build 14A
*Parallel Z-Bar Linkage
*Standard Lift Configuration

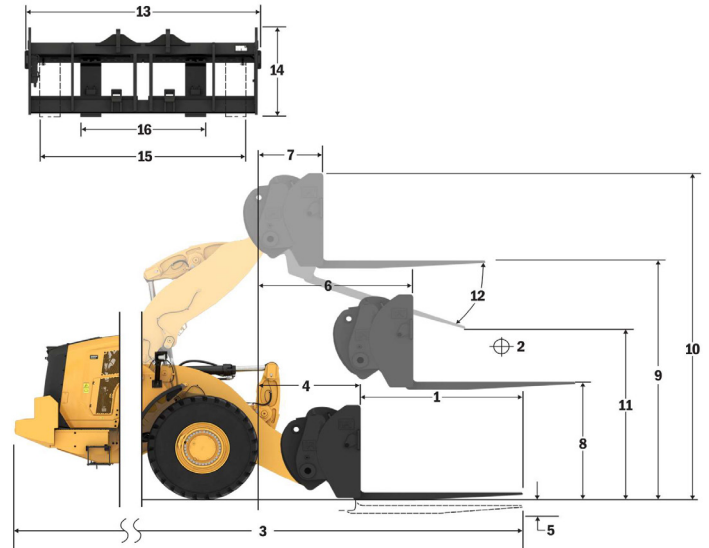

- ◆ Payload (SAE J1197)
- Payload (CEN EN 474-3 - Rough Terrain)
- ▲ Payload (CEN EN 474-3 - Firm & Level)
- ◻ Static Tipping Load - Articulated
- Static Tipping Load - Straight
- ▲ Hydraulic TR Capacity
- Hydraulic LR Capacity

NOTE: Static tipping loads and operating weight are based on the following loader configuration: Bridgestone * VSNT L4 Tires, Air Conditioning, Ride Control, Powertrain Guard, Full Fluids, Fuel Tank, Coolant, Lubricants, and Operator.

Specifications and ratings conform to the following standards: SAE* J1197, ISO 14397-1, CEN** EN 474-3.

The rated operating load for a loader equipped with a pallet fork is determined by:
SAE J1197: 50% of full turn static tipping load or hydraulic limit.
CEN EN 474-3: 60% of full turn static tipping load on rough terrain or hydraulic limit.
CEN EN 474-3: 80% of full turn static tipping load on firm and level ground or hydraulic limit.

*SAE - Society of Automotive Engineers

**CEN - European Committee for Standardization

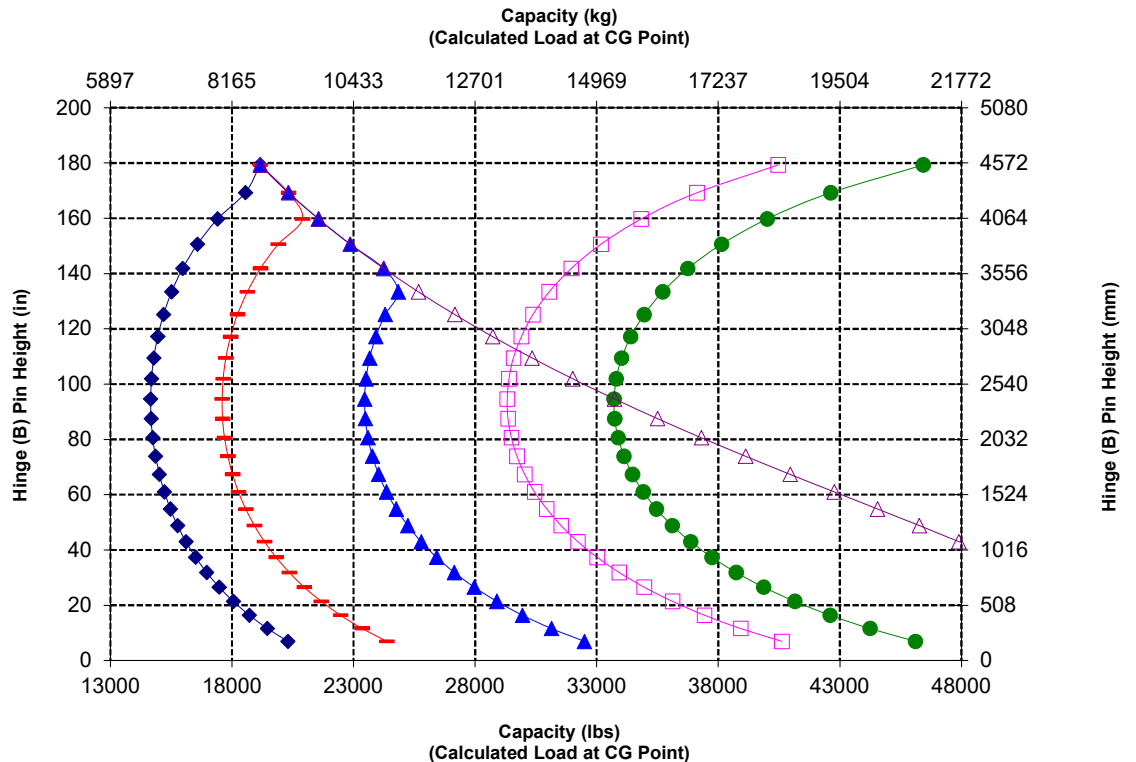

980 Wheel Loader Specifications

Fork Specifications

Fork Specifications

1	Tine Length	mm	2134
		in	84.0
2	Load Center	mm	1067
		in	42.0
	Static Tipping Load - Straight (Forks Level)	kq	14622
		lbs	32227
	Static Tipping Load - Articulated (Forks Level)	kq	12709
		lbs	28010
	Rated Load (SAE J1197 - 50% FTSTL)	kq	6354
		lbs	14005
	Rated Load (CEN EN 474-3 Rough Terrain - 60% FTSTL)	kq	7625
		lbs	16806
	Rated Load (CEN EN 474-3 Firm and Level Ground - 80% FTSTL)	kq	7759
		lbs	17102
3	Maximum Overall Length	mm	10688
		in	420.8
4	Reach with Forks at Ground Level	mm	1141
		in	44.9
5	*Ground to Bottom of Tine at Minimum Height and Fork Level	mm	-65
		in	-2.5
6	Reach with Arms Horizontal and Forks Level	mm	1797
		in	70.7
7	Reach with Fork at Maximum Height	mm	870
		in	34.2
8	Ground to Top of Tine with Arms Horizontal and Fork Level	mm	2135
		in	84.0
9	Ground to Top of Tine at Maximum Height and Fork Level	mm	4403
		in	173.4
10	Overall Height of Fork at Full Lift (top of carriage to ground)	mm	5443
		in	214.3
11	Clearance at Full Lift and Max Dump	mm	2359
		in	92.9
12	Max Discharge Angle from Horizontal	deg	51
13	Overall Carriage Width	mm	2833
		in	111.5
14	Overall Carriage Height	mm	1130
		in	44.5
15	Outside Tine Width (max spread)	mm	2483
		in	97.8
16	Outside Tine Width (min spread)	mm	590
		in	23.2
	Tine Width (single tine)	mm	180.0
		in	7.1
	Tine Thickness	mm	90.0
		in	3.5
	Tine Capacity	kq	12700
		lbs	27991
	Operating Weight	kq	29582
		lbs	65198

*Negative values indicate below grade

980 STD Construction Fork, FUSION

108" Carriage 84" Tine
520-7968 520-7986

*Build 14A
*Parallel Z-Bar Linkage
*Standard Lift Configuration

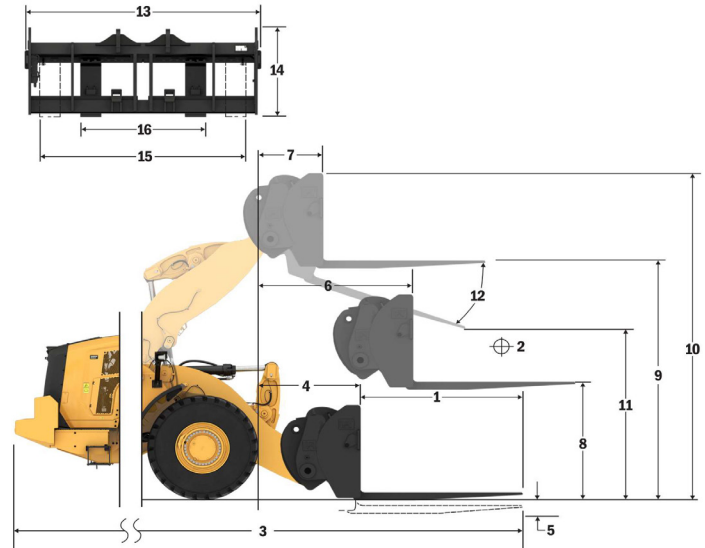

Capacity (kg)
(Calculated Load at CG Point)

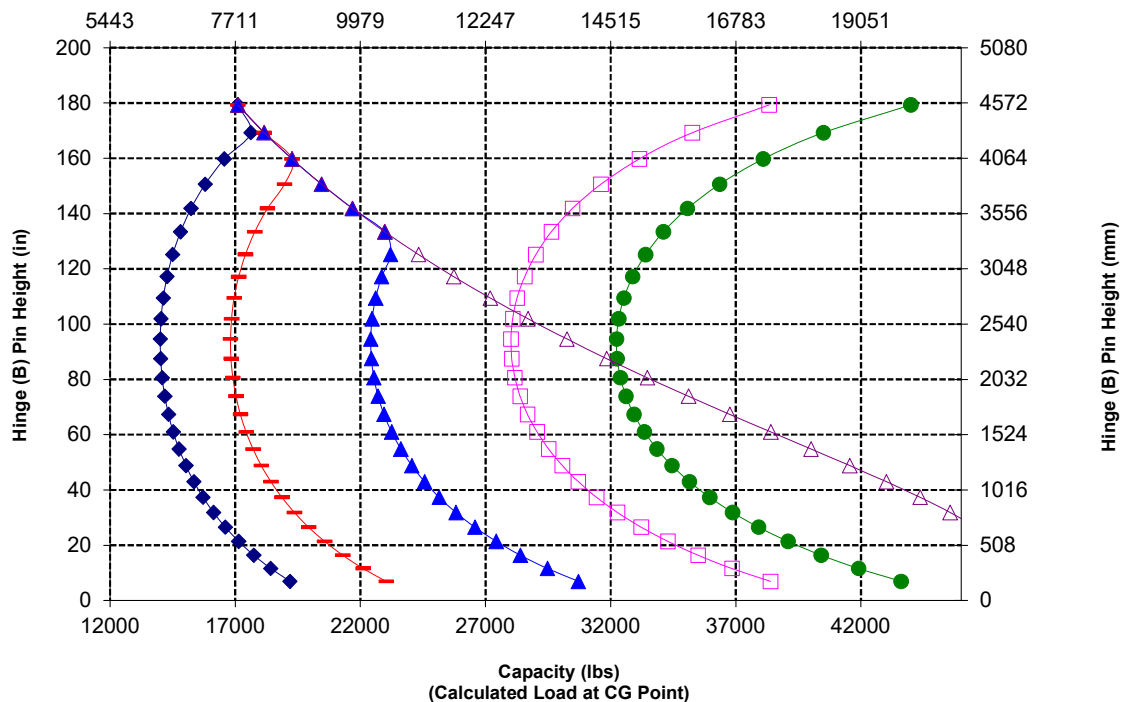

NOTE: Static tipping loads and operating weight are based on the following loader configuration: Bridgestone * VSNT L4 Tires, Air Conditioning, Ride Control, Powertrain Guard, Full Fluids, Fuel Tank, Coolant, Lubricants, and Operator.

Specifications and ratings conform to the following standards: SAE* J1197, ISO 14397-1, CEN** EN 474-3.

The rated operating load for a loader equipped with a pallet fork is determined by:
SAE J1197: 50% of full turn static tipping load or hydraulic limit.
CEN EN 474-3: 60% of full turn static tipping load on rough terrain or hydraulic limit.
CEN EN 474-3: 80% of full turn static tipping load on firm and level ground or hydraulic limit.

*SAE - Society of Automotive Engineers

**CEN - European Committee for Standardization

980 Wheel Loader Specifications

Fork Specifications

Fork Specifications

1	Tine Length	mm	2438
		in	96.0
2	Load Center	mm	1219
		in	48.0
	Static Tipping Load - Straight (Forks Level)	kq	13999
		lbs	30855
	Static Tipping Load - Articulated (Forks Level)	kq	12159
		lbs	26799
	Rated Load (SAE J1197 - 50% FTSTL)	kq	6080
		lbs	13399
	Rated Load (CEN EN 474-3 Rough Terrain - 60% FTSTL)	kq	6988
		lbs	15401
	Rated Load (CEN EN 474-3 Firm and Level Ground - 80% FTSTL)	kq	6988
		lbs	15401
3	Maximum Overall Length	mm	10992
		in	432.8
4	Reach with Forks at Ground Level	mm	1141
		in	44.9
5	*Ground to Bottom of Tine at Minimum Height and Fork Level	mm	-65
		in	-2.5
6	Reach with Arms Horizontal and Forks Level	mm	1797
		in	70.7
7	Reach with Fork at Maximum Height	mm	870
		in	34.2
8	Ground to Top of Tine with Arms Horizontal and Fork Level	mm	2135
		in	84.0
9	Ground to Top of Tine at Maximum Height and Fork Level	mm	4403
		in	173.4
10	Overall Height of Fork at Full Lift (top of carriage to ground)	mm	5443
		in	214.3
11	Clearance at Full Lift and Max Dump	mm	2122
		in	83.5
12	Max Discharge Angle from Horizontal	deg	51
13	Overall Carriage Width	mm	2833
		in	111.5
14	Overall Carriage Height	mm	1130
		in	44.5
15	Outside Tine Width (max spread)	mm	2483
		in	97.8
16	Outside Tine Width (min spread)	mm	590
		in	23.2
	Tine Width (single tine)	mm	180.0
		in	7.1
	Tine Thickness	mm	90.0
		in	3.5
	Tine Capacity	kq	11300
		lbs	24905
	Operating Weight	kq	29645
		lbs	65336

*Negative values indicate below grade

980 STD

Construction Fork, FUSION

108" Carriage

96" Tine

520-7968

520-7981

*Build 14A
*Parallel Z-Bar Linkage
*Standard Lift Configuration

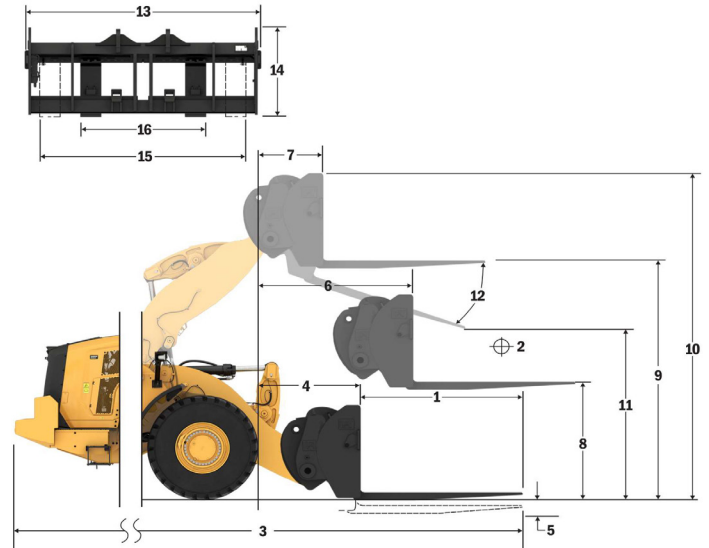

Capacity (kg)
(Calculated Load at CG Point)

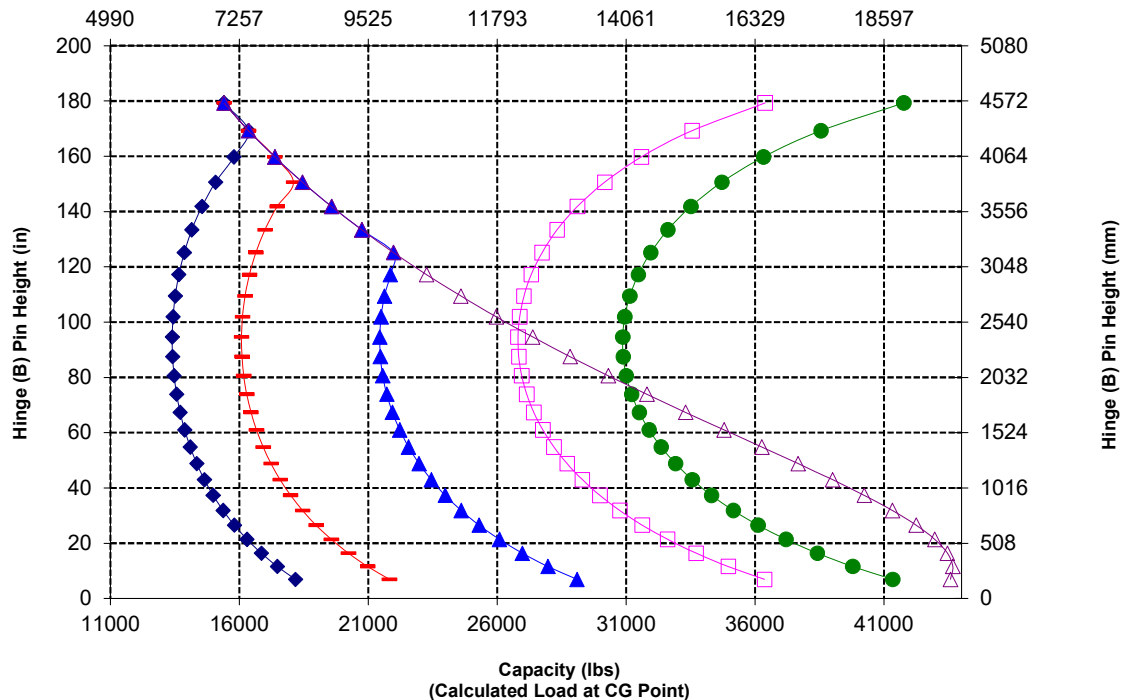

NOTE: Static tipping loads and operating weight are based on the following loader configuration: Bridgestone * VSNT L4 Tires, Air Conditioning, Ride Control, Powertrain Guard, Full Fluids, Fuel Tank, Coolant, Lubricants, and Operator.

Specifications and ratings conform to the following standards: SAE* J1197, ISO 14397-1, CEN** EN 474-3.

The rated operating load for a loader equipped with a pallet fork is determined by:
SAE J1197: 50% of full turn static tipping load or hydraulic limit.
CEN EN 474-3: 60% of full turn static tipping load on rough terrain or hydraulic limit.
CEN EN 474-3: 80% of full turn static tipping load on firm and level ground or hydraulic limit.

*SAE - Society of Automotive Engineers

**CEN - European Committee for Standardization

980 Wheel Loader Specifications

Fork Specifications

Fork Specifications

1	Tine Length	mm	1829
		in	72.0
2	Load Center	mm	914
		in	36.0
	Static Tipping Load - Straight (Forks Level)	kg	14965
		lbs	32984
	Static Tipping Load - Articulated (Forks Level)	kg	12974
		lbs	28595
	Rated Load (SAE J1197 - 50% FTSTL)	kg	6487
		lbs	14298
	Rated Load (CEN EN 474-3 Rough Terrain - 60% FTSTL)	kg	7785
		lbs	17157
	Rated Load (CEN EN 474-3 Firm and Level Ground - 80% FTSTL)	kg	8905
		lbs	19627
3	Maximum Overall Length	mm	10404
		in	409.6
4	Reach with Forks at Ground Level	mm	1162
		in	45.8
5	*Ground to Bottom of Tine at Minimum Height and Fork Level	mm	-99
		in	-3.9
6	Reach with Arms Horizontal and Forks Level	mm	1796
		in	70.7
7	Reach with Fork at Maximum Height	mm	869
		in	34.2
8	Ground to Top of Tine with Arms Horizontal and Fork Level	mm	2095
		in	82.5
9	Ground to Top of Tine at Maximum Height and Fork Level	mm	4364
		in	171.8
10	Overall Height of Fork at Full Lift (top of carriage to ground)	mm	5407
		in	212.9
11	Clearance at Full Lift and Max Dump	mm	2498
		in	98.3
12	Max Discharge Angle from Horizontal	deg	55
13	Overall Carriage Width	mm	2821
		in	111.1
14	Overall Carriage Height	mm	1129
		in	44.4
15	Outside Tine Width (max spread)	mm	2627
		in	103.4
16	Outside Tine Width (min spread)	mm	747
		in	29.4
	Tine Width (single tine)	mm	250.0
		in	9.8
	Tine Thickness	mm	85.0
		in	3.3
	Tine Capacity	kg	18700
		lbs	41215
	Operating Weight	kg	29958
		lbs	66026

*Negative values indicate below grade

980 STD Construction Fork, HD, FUSION

108" Carriage 72" Tine
523-4199 523-4200

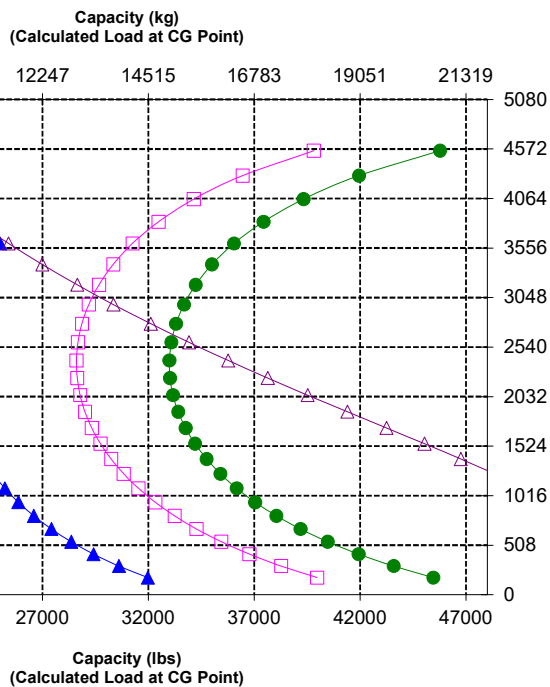
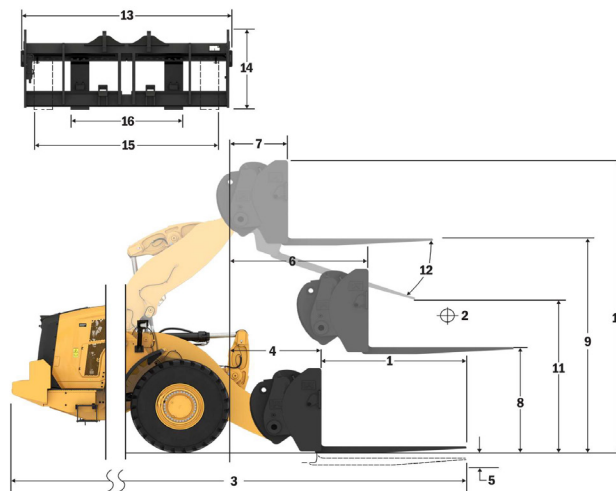

NOTE: Static tipping loads and operating weight are based on the following loader configuration: Bridgestone™ VSNLT L4 Tires, Air Conditioning, Ride Control, Powertrain Guard, Full Fluids, Fuel Tank, Coolant, Lubricants, and Operator.

Specifications and ratings conform to the following standards: SAE® J1197, ISO 14397-1, CEN** EN 474-3.

The rated operating load for a loader equipped with a pallet fork is determined by:
SAE J1197: 50% of full turn static tipping load or hydraulic limit.
CEN EN 474-3: 60% of full turn static tipping load on rough terrain or hydraulic limit.
CEN EN 474-3: 80% of full turn static tipping load on firm and level ground or hydraulic limit.

*SAE - Society of Automotive Engineers
**CEN - European Committee for Standardization



WARNING: Do not exceed tine load capacity. Individual tine capacity is stamped on the side of each tine.

980 Wheel Loader Specifications

Fork Specifications

Fork Specifications

1	Tine Length	mm	2134
		in	84.0
2	Load Center	mm	1067
		in	42.0
	Static Tipping Load - Straight (Forks Level)	kg	14267
		lbs	31445
	Static Tipping Load - Articulated (Forks Level)	kg	12355
		lbs	27231
	Rated Load (SAE J1197 - 50% FTSTL)	kg	6178
		lbs	13615
	Rated Load (CEN EN 474-3 Rough Terrain - 60% FTSTL)	kg	7413
		lbs	16338
	Rated Load (CEN EN 474-3 Firm and Level Ground - 80% FTSTL)	kg	7914
		lbs	17442
3	Maximum Overall Length	mm	10713
		in	421.8
4	Reach with Forks at Ground Level	mm	1166
		in	45.9
5	*Ground to Bottom of Tine at Minimum Height and Fork Level	mm	-99
		in	-3.9
6	Reach with Arms Horizontal and Forks Level	mm	1796
		in	70.7
7	Reach with Fork at Maximum Height	mm	869
		in	34.2
8	Ground to Top of Tine with Arms Horizontal and Fork Level	mm	2100
		in	82.7
9	Ground to Top of Tine at Maximum Height and Fork Level	mm	4369
		in	172.0
10	Overall Height of Fork at Full Lift (top of carriage to ground)	mm	5407
		in	212.9
11	Clearance at Full Lift and Max Dump	mm	2247
		in	88.5
12	Max Discharge Angle from Horizontal	deg	55
13	Overall Carriage Width	mm	2821
		in	111.1
14	Overall Carriage Height	mm	1129
		in	44.4
15	Outside Tine Width (max spread)	mm	2627
		in	103.4
16	Outside Tine Width (min spread)	mm	747
		in	29.4
	Tine Width (single tine)	mm	250.0
		in	9.8
	Tine Thickness	mm	90.0
		in	3.5
	Tine Capacity	kg	17729
		lbs	39075
	Operating Weight	kg	30060
		lbs	66251

*Negative values indicate below grade

980 STD Construction Fork, HD, FUSION 108" Carriage 84" Tine 523-4199 523-4201

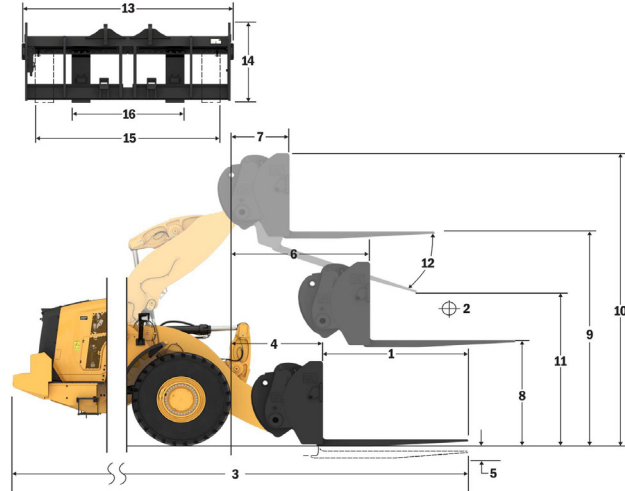

Capacity (kg)
(Calculated Load at CG Point)

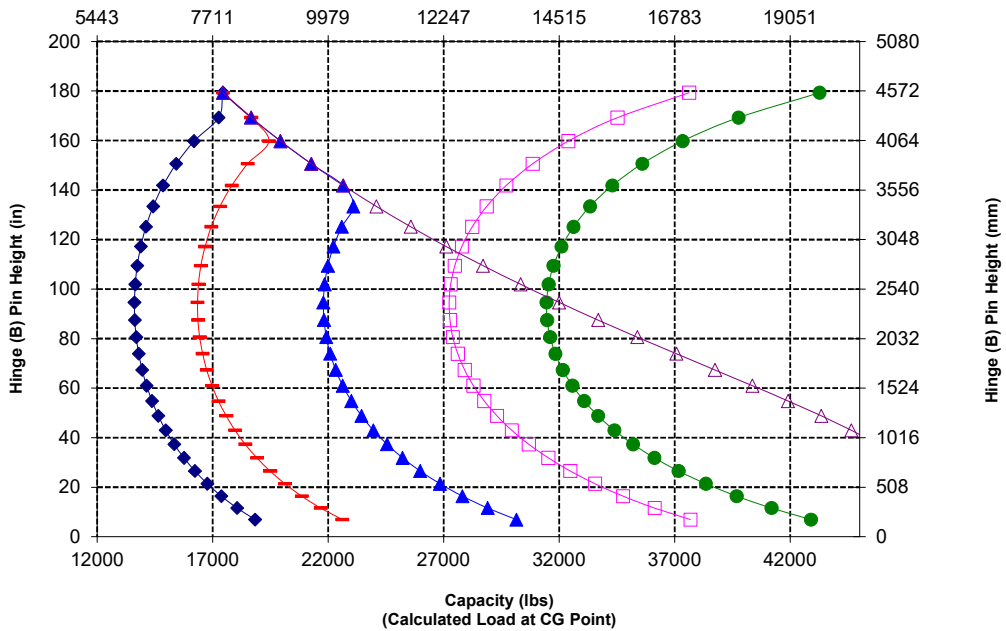

NOTE: Static tipping loads and operating weight are based on the following loader configuration: Bridgestone® VSNT L4 Tires, Air Conditioning, Ride Control, Powertrain Guard, Full Fluids, Fuel Tank, Coolant, Lubricants, and Operator.

Specifications and ratings conform to the following standards: SAE® J1197, ISO 14397-1, CEN** EN 474-3.

The rated operating load for a loader equipped with a pallet fork is determined by:
SAE J1197: 50% of full turn static tipping load or hydraulic limit.
CEN EN 474-3: 60% of full turn static tipping load on rough terrain or hydraulic limit.
CEN EN 474-3: 80% of full turn static tipping load on firm and level ground or hydraulic limit.

*SAE - Society of Automotive Engineers
**CEN - European Committee for Standardization



WARNING: Do not exceed tine load capacity. Individual tine capacity is stamped on the side of each tine.

980 Wheel Loader Specifications

Fork Specifications

Fork Specifications

1	Tine Length	mm	2438
		in	96.0
2	Load Center	mm	1219
		in	48.0
	Static Tipping Load - Straight (Forks Level)	kg	13562
		lbs	29890
	Static Tipping Load - Articulated (Forks Level)	kg	11724
		lbs	25839
	Rated Load (SAE J1197 - 50% FTSTL)	kg	5862
		lbs	12920
	Rated Load (CEN EN 474-3 Rough Terrain - 60% FTSTL)	kg	7034
		lbs	15504
	Rated Load (CEN EN 474-3 Firm and Level Ground - 80% FTSTL)	kg	7041
		lbs	15518
3	Maximum Overall Length	mm	11021
		in	433.9
4	Reach with Forks at Ground Level	mm	1170
		in	46.1
5	*Ground to Bottom of Tine at Minimum Height and Fork Level	mm	-98
		in	-3.8
6	Reach with Arms Horizontal and Forks Level	mm	1801
		in	70.9
7	Reach with Fork at Maximum Height	mm	874
		in	34.4
8	Ground to Top of Tine with Arms Horizontal and Fork Level	mm	2102
		in	82.7
9	Ground to Top of Tine at Maximum Height and Fork Level	mm	4370
		in	172.1
10	Overall Height of Fork at Full Lift (top of carriage to ground)	mm	5407
		in	212.9
11	Clearance at Full Lift and Max Dump	mm	1994
		in	78.5
12	Max Discharge Angle from Horizontal	deg	55
13	Overall Carriage Width	mm	2821
		in	111.1
14	Overall Carriage Height	mm	1127
		in	44.4
15	Outside Tine Width (max spread)	mm	2629
		in	103.5
16	Outside Tine Width (min spread)	mm	747
		in	29.4
	Tine Width (single tine)	mm	250.0
		in	9.8
	Tine Thickness	mm	90.0
		in	3.5
	Tine Capacity	kg	15750
		lbs	34713
	Operating Weight	kg	30211
		lbs	66584

*Negative values indicate below grade

980 STD Construction Fork, HD, FUSION

108" Carriage 96" Tine
523-4199 523-4202

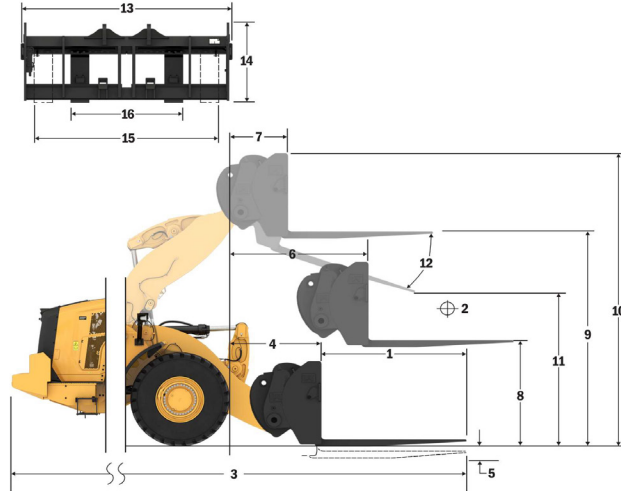

NOTE: Static tipping loads and operating weight are based on the following loader configuration: Bridgestone™ VSNLT L4 Tires, Air Conditioning, Ride Control, Powertrain Guard, Full Fluids, Fuel Tank, Coolant, Lubricants, and Operator.

Specifications and ratings conform to the following standards: SAE® J1197, ISO 14397-1, CEN** EN 474-3.

The rated operating load for a loader equipped with a pallet fork is determined by:
SAE J1197: 50% of full turn static tipping load or hydraulic limit.
CEN EN 474-3: 60% of full turn static tipping load on rough terrain or hydraulic limit.
CEN EN 474-3: 80% of full turn static tipping load on firm and level ground or hydraulic limit.

*SAE - Society of Automotive Engineers
**CEN - European Committee for Standardization

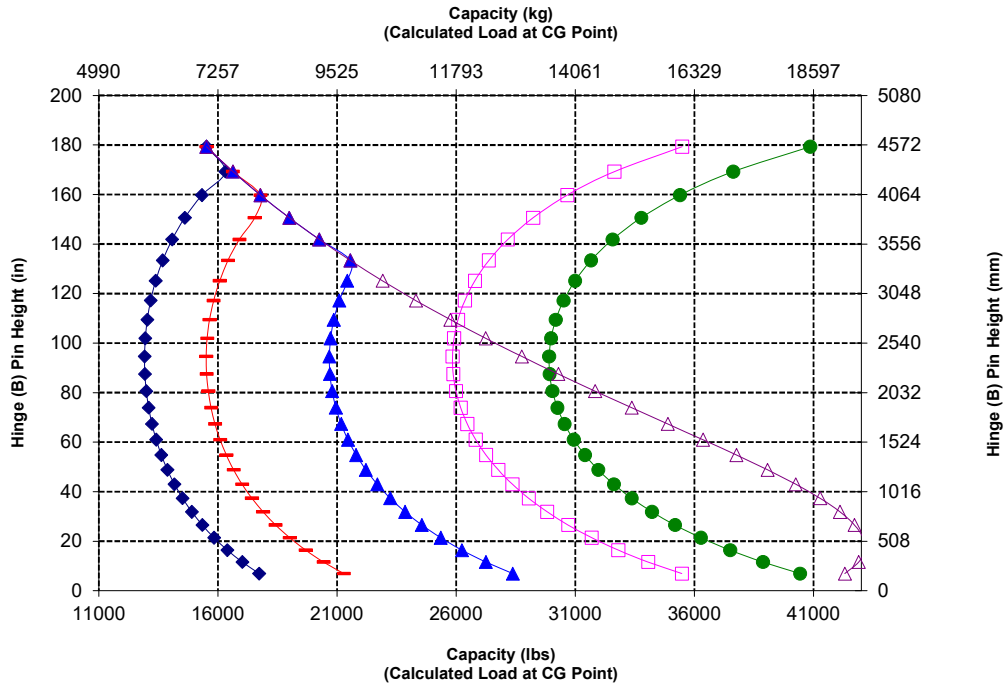

WARNING: Do not exceed tine load capacity. Individual tine capacity is stamped on the side of each tine.

980 Wheel Loader Specifications

Fork Specifications

Fork Specifications

1	Tine Length	mm	1830
		in	72.0
2	Load Center	mm	915
		in	36.0
	Static Tipping Load - Straight (Forks Level)	kq	14666
		lbs	32325
	Static Tipping Load - Articulated (Forks Level)	kq	13039
		lbs	28737
	Rated Load (SAE J1197 - 50% FTSTL)	kq	6519
		lbs	14369
	Rated Load (CEN EN 474-3 Rough Terrain - 60% FTSTL)	kq	7823
		lbs	17242
	Rated Load (CEN EN 474-3 Firm and Level Ground - 80% FTSTL)	kq	7970
		lbs	17566
3	Maximum Overall Length	mm	10650
		in	419.3
4	Reach with Forks at Ground Level	mm	1407
		in	55.4
5	*Ground to Bottom of Tine at Minimum Height and Fork Level	mm	-149
		in	-5.9
6	Reach with Arms Horizontal and Forks Level	mm	1982
		in	78.0
7	Reach with Fork at Maximum Height	mm	898
		in	35.4
8	Ground to Top of Tine with Arms Horizontal and Fork Level	mm	2023
		in	79.6
9	Ground to Top of Tine at Maximum Height and Fork Level	mm	4512
		in	177.7
10	Overall Height of Fork at Full Lift (top of carriage to ground)	mm	5287
		in	208.2
11	Clearance at Full Lift and Max Dump	mm	2842
		in	111.9
12	Max Discharge Angle from Horizontal	deg	47
13	Overall Carriage Width	mm	2217
		in	87.3
14	Overall Carriage Height	mm	840
		in	33.1
15	Outside Tine Width (max spread)	mm	2070
		in	81.5
16	Outside Tine Width (min spread)	mm	470
		in	18.5
	Tine Width (single tine)	mm	150.0
		in	5.9
	Tine Thickness	mm	65.0
		in	2.6
	Tine Capacity	kq	5246
		lbs	11562
	Operating Weight	kq	29218
		lbs	64396

*Negative values indicate below grade

980 HL Pallet Fork, FUSION

87" Carriage 72" Tine
530-1861 530-1869

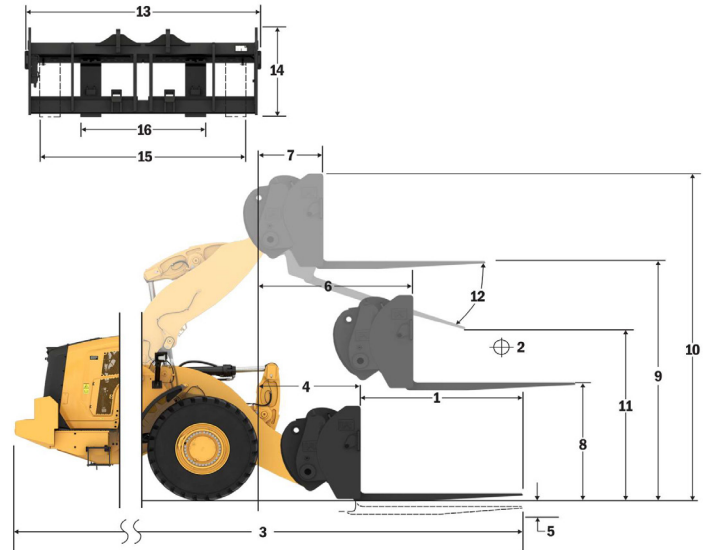

Capacity (kg) (Calculated Load at CG Point)

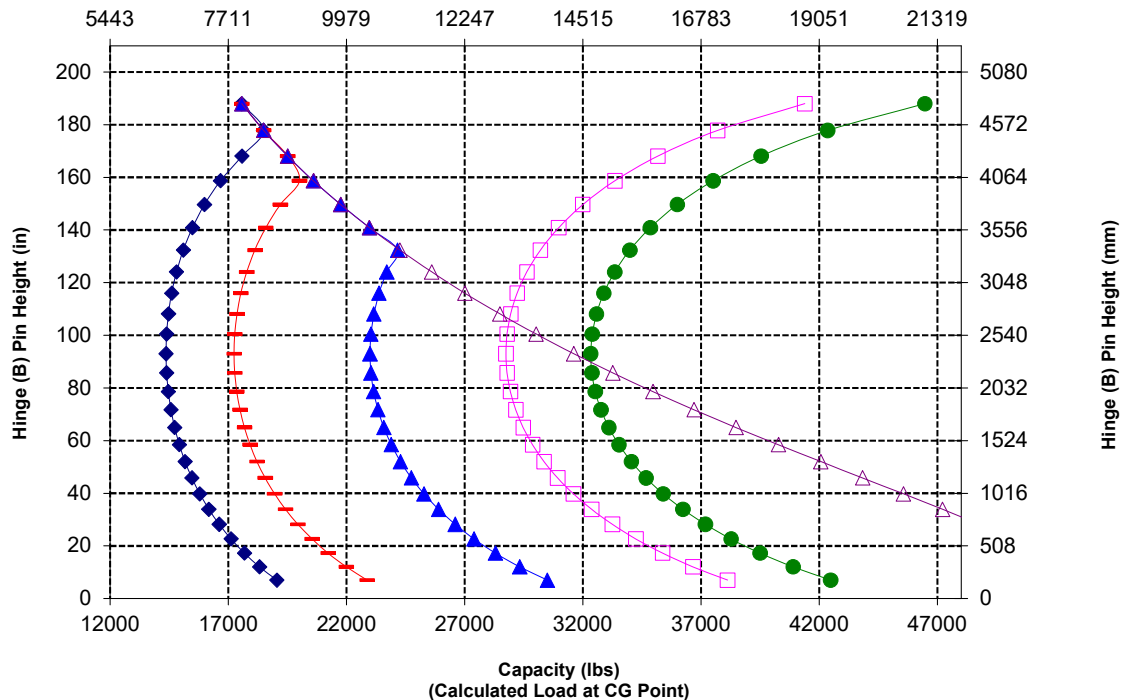

980 Wheel Loader Specifications

Fork Specifications

Fork Specifications

1	Tine Length	mm	1829
		in	72.0
2	Load Center	mm	915
		in	36.0
	Static Tipping Load - Straight (Forks Level)	kq	14378
		lbs	31689
	Static Tipping Load - Articulated (Forks Level)	kq	12744
		lbs	28088
	Rated Load (SAE J1197 - 50% FTSTL)	kq	6372
		lbs	14044
	Rated Load (CEN EN 474-3 Rough Terrain - 60% FTSTL)	kq	7646
		lbs	16853
	Rated Load (CEN EN 474-3 Firm and Level Ground - 80% FTSTL)	kq	8359
		lbs	18422
3	Maximum Overall Length	mm	10593
		in	417.1
4	Reach with Forks at Ground Level	mm	1351
		in	53.2
5	*Ground to Bottom of Tine at Minimum Height and Fork Level	mm	-62
		in	-2.4
6	Reach with Arms Horizontal and Forks Level	mm	1970
		in	77.5
7	Reach with Fork at Maximum Height	mm	886
		in	34.9
8	Ground to Top of Tine with Arms Horizontal and Fork Level	mm	2135
		in	84.1
9	Ground to Top of Tine at Maximum Height and Fork Level	mm	4625
		in	182.1
10	Overall Height of Fork at Full Lift (top of carriage to ground)	mm	5665
		in	223.0
11	Clearance at Full Lift and Max Dump	mm	2768
		in	109.0
12	Max Discharge Angle from Horizontal	deg	53
13	Overall Carriage Width	mm	2833
		in	111.5
14	Overall Carriage Height	mm	1130
		in	44.5
15	Outside Tine Width (max spread)	mm	2483
		in	97.8
16	Outside Tine Width (min spread)	mm	590
		in	23.2
	Tine Width (single tine)	mm	180.0
		in	7.1
	Tine Thickness	mm	90.0
		in	3.5
	Tine Capacity	kq	14800
		lbs	32619
	Operating Weight	kq	29657
		lbs	65364

*Negative values indicate below grade

980 HL Construction Fork, FUSION

108" Carriage 72" Tine
520-7968 520-7979

*Build 14A
*Parallel Z-Bar Linkage
*High Lift Configuration

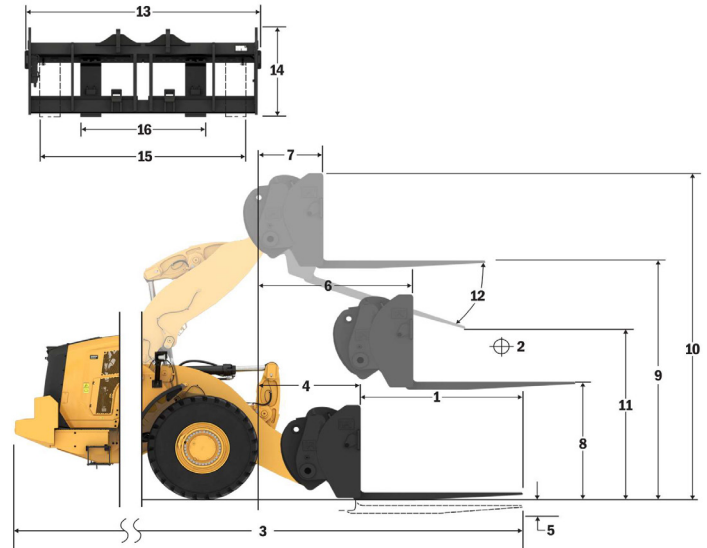

- ◆ Payload (SAE J1197)
- Payload (CEN EN 474-3 - Rough Terrain)
- ▲ Payload (CEN EN 474-3 - Firm & Level)
- ◻ Static Tipping Load - Articulated
- Static Tipping Load - Straight
- ▲ Hydraulic TR Capacity
- Hydraulic LR Capacity

NOTE: Static tipping loads and operating weight are based on the following loader configuration: Bridgestone * VSNT L4 Tires, Air Conditioning, Ride Control, Powertrain Guard, Full Fluids, Fuel Tank, Coolant, Lubricants, and Operator.

Specifications and ratings conform to the following standards: SAE* J1197, ISO 14397-1, CEN** EN 474-3.

The rated operating load for a loader equipped with a pallet fork is determined by:
SAE J1197: 50% of full turn static tipping load or hydraulic limit.
CEN EN 474-3: 60% of full turn static tipping load on rough terrain or hydraulic limit.
CEN EN 474-3: 80% of full turn static tipping load on firm and level ground or hydraulic limit.

*SAE - Society of Automotive Engineers

**CEN - European Committee for Standardization

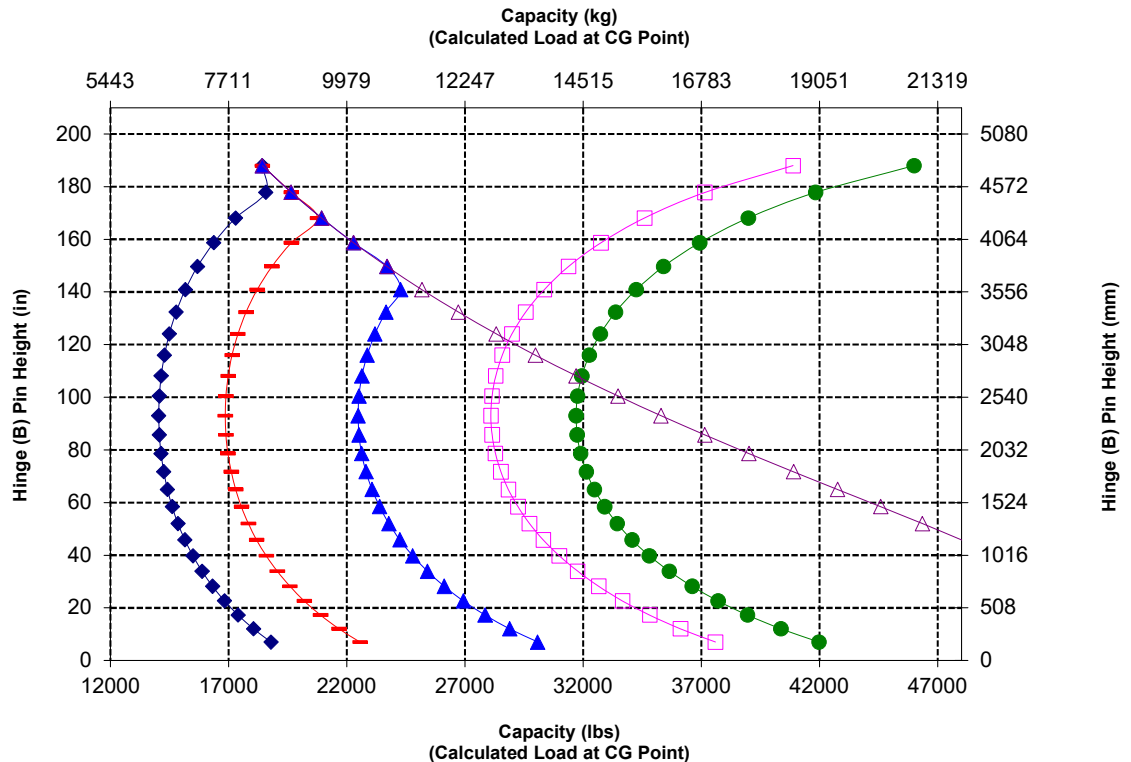

980 Wheel Loader Specifications

Fork Specifications

Fork Specifications

1	Tine Length	mm	2134
		in	84.0
2	Load Center	mm	1067
		in	42.0
	Static Tipping Load - Straight (Forks Level)	kq	13768
		lbs	30345
	Static Tipping Load - Articulated (Forks Level)	kq	12196
		lbs	26880
	Rated Load (SAE J1197 - 50% FTSTL)	kq	6098
		lbs	13440
	Rated Load (CEN EN 474-3 Rough Terrain - 60% FTSTL)	kq	7318
		lbs	16128
	Rated Load (CEN EN 474-3 Firm and Level Ground - 80% FTSTL)	kq	7467
		lbs	16457
3	Maximum Overall Length	mm	10898
		in	429.1
4	Reach with Forks at Ground Level	mm	1351
		in	53.2
5	*Ground to Bottom of Tine at Minimum Height and Fork Level	mm	-62
		in	-2.4
6	Reach with Arms Horizontal and Forks Level	mm	1970
		in	77.5
7	Reach with Fork at Maximum Height	mm	886
		in	34.9
8	Ground to Top of Tine with Arms Horizontal and Fork Level	mm	2135
		in	84.1
9	Ground to Top of Tine at Maximum Height and Fork Level	mm	4625
		in	182.1
10	Overall Height of Fork at Full Lift (top of carriage to ground)	mm	5665
		in	223.0
11	Clearance at Full Lift and Max Dump	mm	2524
		in	99.4
12	Max Discharge Angle from Horizontal	deg	53
13	Overall Carriage Width	mm	2833
		in	111.5
14	Overall Carriage Height	mm	1130
		in	44.5
15	Outside Tine Width (max spread)	mm	2483
		in	97.8
16	Outside Tine Width (min spread)	mm	590
		in	23.2
	Tine Width (single tine)	mm	180.0
		in	7.1
	Tine Thickness	mm	90.0
		in	3.5
	Tine Capacity	kq	12700
		lbs	27991
	Operating Weight	kq	29719
		lbs	65501

*Negative values indicate below grade

980 HL Construction Fork, FUSION

108" Carriage

84" Tine

520-7968

520-7986

*Build 14A
*Parallel Z-Bar Linkage
*High Lift Configuration

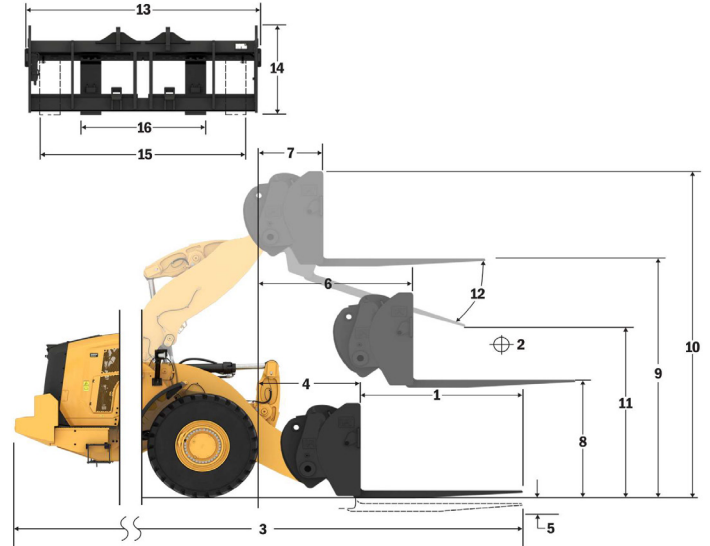

Capacity (kg)
(Calculated Load at CG Point)

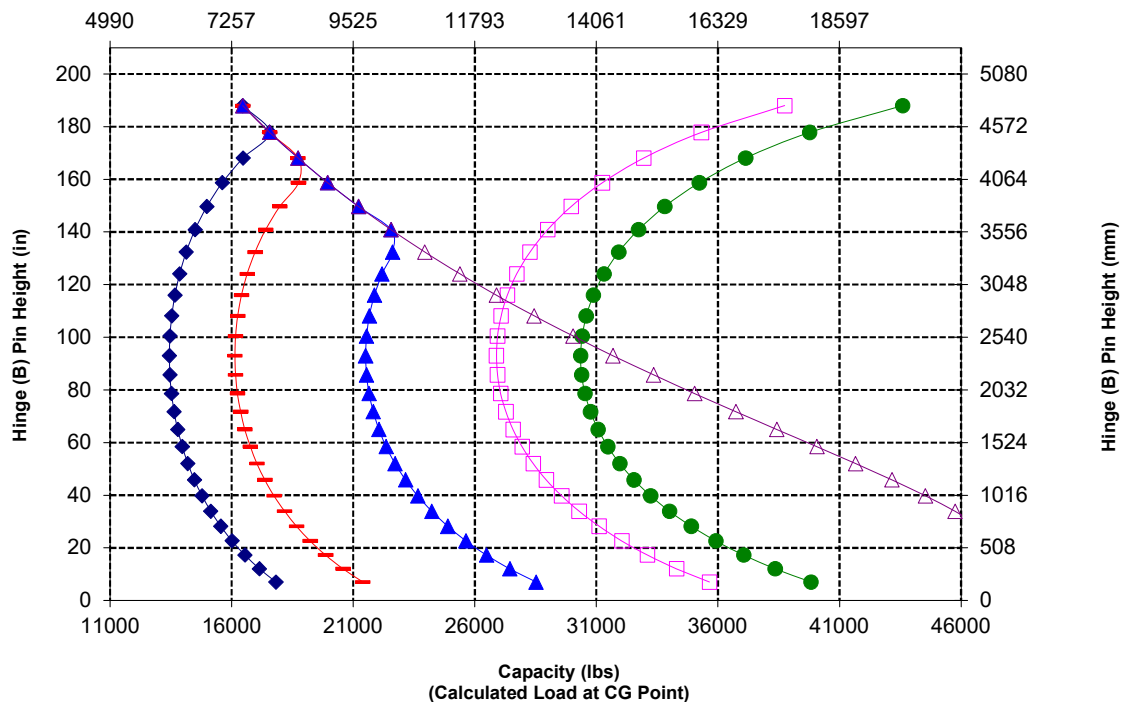

NOTE: Static tipping loads and operating weight are based on the following loader configuration: Bridgestone * VSNT L4 Tires, Air Conditioning, Ride Control, Powertrain Guard, Full Fluids, Fuel Tank, Coolant, Lubricants, and Operator.

Specifications and ratings conform to the following standards: SAE* J1197, ISO 14397-1, CEN** EN 474-3.

The rated operating load for a loader equipped with a pallet fork is determined by:
SAE J1197: 50% of full turn static tipping load or hydraulic limit.
CEN EN 474-3: 60% of full turn static tipping load on rough terrain or hydraulic limit.
CEN EN 474-3: 80% of full turn static tipping load on firm and level ground or hydraulic limit.

*SAE - Society of Automotive Engineers

**CEN - European Committee for Standardization

980 Wheel Loader Specifications

Fork Specifications

Fork Specifications

1	Tine Length	mm	2438
		in	96.0
2	Load Center	mm	1219
		in	48.0
	Static Tipping Load - Straight (Forks Level)	kq	13199
		lbs	29091
	Static Tipping Load - Articulated (Forks Level)	kq	11685
		lbs	25753
	Rated Load (SAE J1197 - 50% FTSTL)	kq	5842
		lbs	12876
	Rated Load (CEN EN 474-3 Rough Terrain - 60% FTSTL)	kq	6727
		lbs	14826
	Rated Load (CEN EN 474-3 Firm and Level Ground - 80% FTSTL)	kq	6727
		lbs	14826
3	Maximum Overall Length	mm	11202
		in	441.0
4	Reach with Forks at Ground Level	mm	1351
		in	53.2
5	*Ground to Bottom of Tine at Minimum Height and Fork Level	mm	-62
		in	-2.4
6	Reach with Arms Horizontal and Forks Level	mm	1970
		in	77.5
7	Reach with Fork at Maximum Height	mm	886
		in	34.9
8	Ground to Top of Tine with Arms Horizontal and Fork Level	mm	2135
		in	84.1
9	Ground to Top of Tine at Maximum Height and Fork Level	mm	4625
		in	182.1
10	Overall Height of Fork at Full Lift (top of carriage to ground)	mm	5665
		in	223.0
11	Clearance at Full Lift and Max Dump	mm	2280
		in	89.8
12	Max Discharge Angle from Horizontal	deg	53
13	Overall Carriage Width	mm	2833
		in	111.5
14	Overall Carriage Height	mm	1130
		in	44.5
15	Outside Tine Width (max spread)	mm	2483
		in	97.8
16	Outside Tine Width (min spread)	mm	590
		in	23.2
	Tine Width (single tine)	mm	180.0
		in	7.1
	Tine Thickness	mm	90.0
		in	3.5
	Tine Capacity	kq	11300
		lbs	24905
	Operating Weight	kq	29782
		lbs	65640

*Negative values indicate below grade

980 HL Construction Fork, FUSION

108" Carriage

96" Tine

520-7968

520-7981

*Build 14A
*Parallel Z-Bar Linkage
*High Lift Configuration

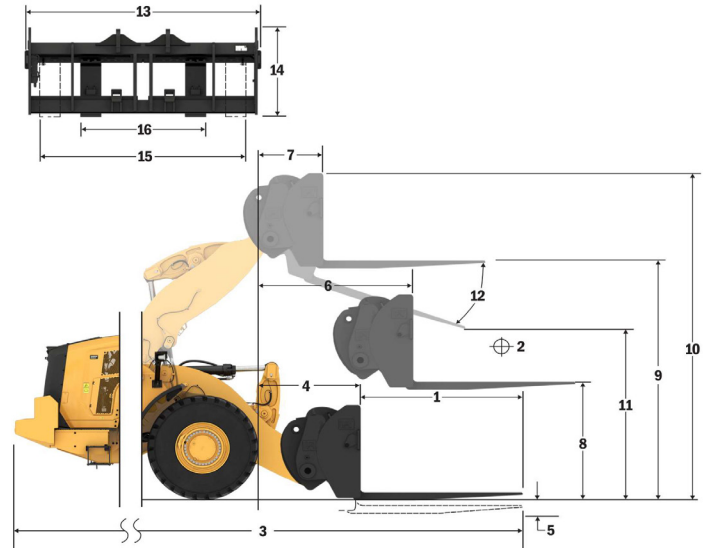

- ◆ Payload (SAE J1197)
- Payload (CEN EN 474-3 - Rough Terrain)
- ▲ Payload (CEN EN 474-3 - Firm & Level)
- ◻ Static Tipping Load - Articulated
- Static Tipping Load - Straight
- ▲ Hydraulic TR Capacity
- Hydraulic LR Capacity

NOTE: Static tipping loads and operating weight are based on the following loader configuration: Bridgestone * VSNT L4 Tires, Air Conditioning, Ride Control, Powertrain Guard, Full Fluids, Fuel Tank, Coolant, Lubricants, and Operator.

Specifications and ratings conform to the following standards: SAE* J1197, ISO 14397-1, CEN** EN 474-3.

The rated operating load for a loader equipped with a pallet fork is determined by:
SAE J1197: 50% of full turn static tipping load or hydraulic limit.
CEN EN 474-3: 60% of full turn static tipping load on rough terrain or hydraulic limit.
CEN EN 474-3: 80% of full turn static tipping load on firm and level ground or hydraulic limit.

*SAE - Society of Automotive Engineers

**CEN - European Committee for Standardization

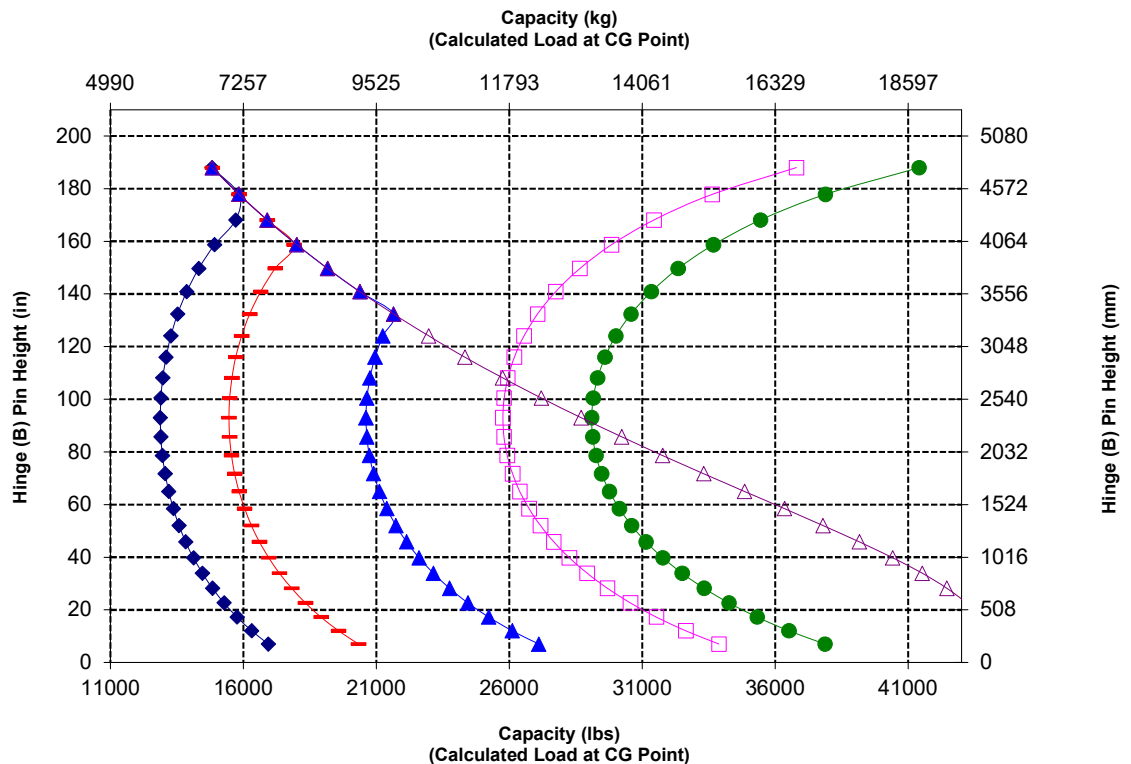

980 Wheel Loader Specifications

Fork Specifications

Fork Specifications

1	Tine Length	mm	1829
		in	72.0
2	Load Center	mm	914
		in	36.0
	Static Tipping Load - Straight (Forks Level)	kg	14048
		lbs	30961
	Static Tipping Load - Articulated (Forks Level)	kg	12414
		lbs	27362
	Rated Load (SAE J1197 - 50% FTSTL)	kg	6207
		lbs	13681
	Rated Load (CEN EN 474-3 Rough Terrain - 60% FTSTL)	kg	7449
		lbs	16417
	Rated Load (CEN EN 474-3 Firm and Level Ground - 80% FTSTL)	kg	8586
		lbs	18924
3	Maximum Overall Length	mm	10612
		in	417.8
4	Reach with Forks at Ground Level	mm	1371
		in	54.0
5	*Ground to Bottom of Tine at Minimum Height and Fork Level	mm	-96
		in	-3.8
6	Reach with Arms Horizontal and Forks Level	mm	1969
		in	77.5
7	Reach with Fork at Maximum Height	mm	885
		in	34.8
8	Ground to Top of Tine with Arms Horizontal and Fork Level	mm	2097
		in	82.5
9	Ground to Top of Tine at Maximum Height and Fork Level	mm	4586
		in	180.5
10	Overall Height of Fork at Full Lift (top of carriage to ground)	mm	5630
		in	221.6
11	Clearance at Full Lift and Max Dump	mm	2674
		in	105.3
12	Max Discharge Angle from Horizontal	deg	57
13	Overall Carriage Width	mm	2821
		in	111.1
14	Overall Carriage Height	mm	1129
		in	44.4
15	Outside Tine Width (max spread)	mm	2627
		in	103.4
16	Outside Tine Width (min spread)	mm	747
		in	29.4
	Tine Width (single tine)	mm	250.0
		in	9.8
	Tine Thickness	mm	85.0
		in	3.3
	Tine Capacity	kg	18700
		lbs	41215
	Operating Weight	kg	30095
		lbs	66329

*Negative values indicate below grade

980 HL Construction Fork, HD, FUSION

108" Carriage 72" Tine
523-4199 523-4200

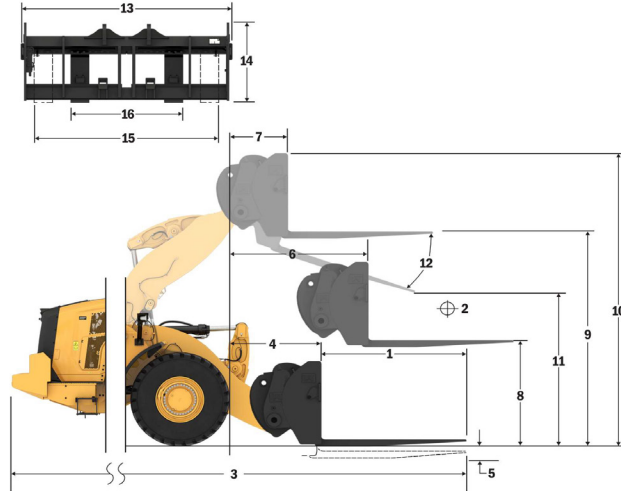

Capacity (kg)
(Calculated Load at CG Point)

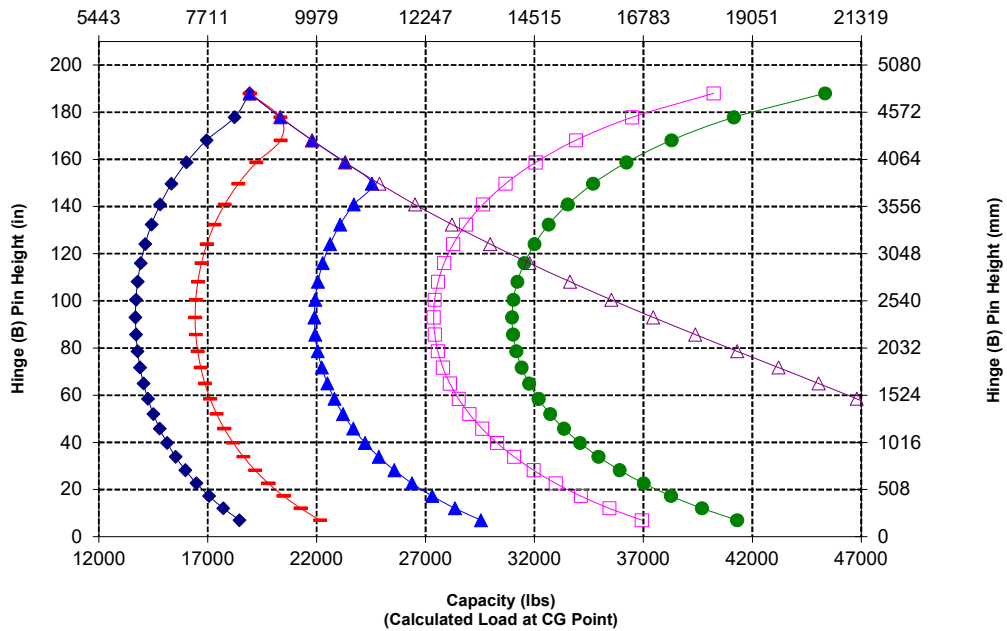

NOTE: Static tipping loads and operating weight are based on the following loader configuration: Bridgestone™ VSNLT L4 Tires, Air Conditioning, Ride Control, Powertrain Guard, Full Fluids, Fuel Tank, Coolant, Lubricants, and Operator.

Specifications and ratings conform to the following standards: SAE® J1197, ISO 14397-1, CEN** EN 474-3.

The rated operating load for a loader equipped with a pallet fork is determined by:
SAE J1197: 50% of full turn static tipping load or hydraulic limit.
CEN EN 474-3: 60% of full turn static tipping load on rough terrain or hydraulic limit.
CEN EN 474-3: 80% of full turn static tipping load on firm and level ground or hydraulic limit.

*SAE - Society of Automotive Engineers
**CEN - European Committee for Standardization



WARNING: Do not exceed tine load capacity. Individual tine capacity is stamped on the side of each tine.

980 Wheel Loader Specifications

Fork Specifications

Fork Specifications

1	Tine Length	mm	2134
		in	84.0
2	Load Center	mm	1067
		in	42.0
	Static Tipping Load - Straight (Forks Level)	kg	13409
		lbs	29553
	Static Tipping Load - Articulated (Forks Level)	kg	11838
		lbs	26090
	Rated Load (SAE J1197 - 50% FTSTL)	kg	5919
		lbs	13045
	Rated Load (CEN EN 474-3 Rough Terrain - 60% FTSTL)	kg	7103
		lbs	15654
	Rated Load (CEN EN 474-3 Firm and Level Ground - 80% FTSTL)	kg	7633
		lbs	16824
3	Maximum Overall Length	mm	10921
		in	429.9
4	Reach with Forks at Ground Level	mm	1374
		in	54.1
5	*Ground to Bottom of Tine at Minimum Height and Fork Level	mm	-96
		in	-3.8
6	Reach with Arms Horizontal and Forks Level	mm	1969
		in	77.5
7	Reach with Fork at Maximum Height	mm	885
		in	34.8
8	Ground to Top of Tine with Arms Horizontal and Fork Level	mm	2102
		in	82.7
9	Ground to Top of Tine at Maximum Height and Fork Level	mm	4591
		in	180.7
10	Overall Height of Fork at Full Lift (top of carriage to ground)	mm	5630
		in	221.6
11	Clearance at Full Lift and Max Dump	mm	2418
		in	95.2
12	Max Discharge Angle from Horizontal	deg	57
13	Overall Carriage Width	mm	2821
		in	111.1
14	Overall Carriage Height	mm	1129
		in	44.4
15	Outside Tine Width (max spread)	mm	2627
		in	103.4
16	Outside Tine Width (min spread)	mm	747
		in	29.4
	Tine Width (single tine)	mm	250.0
		in	9.8
	Tine Thickness	mm	90.0
		in	3.5
	Tine Capacity	kg	17729
		lbs	39075
	Operating Weight	kg	30197
		lbs	66554

*Negative values indicate below grade

980 HL Construction Fork, HD, FUSION 108" Carriage 84" Tine 523-4199 523-4201

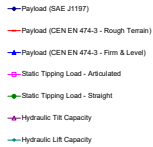
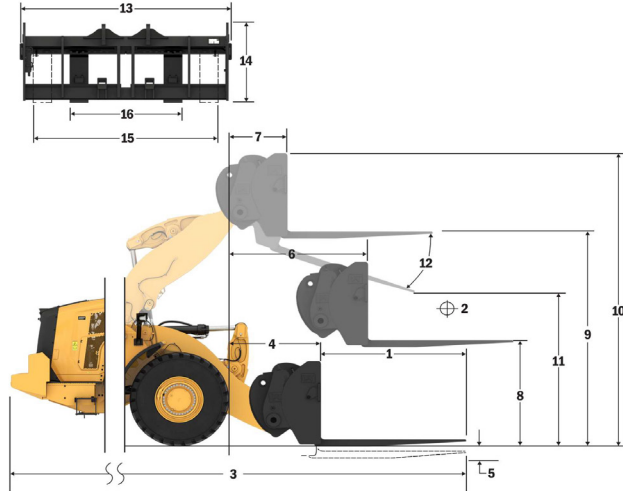

NOTE: Static tipping loads and operating weight are based on the following loader configuration: Bridgestone * VSNT L4 Tires, Air Conditioning, Ride Control, Powertrain Guard, Full Fluids, Fuel Tank, Coolant, Lubricants, and Operator.

Specifications and ratings conform to the following standards: SAE* J1197, ISO 14397-1, CEN** EN 474-3.

The rated operating load for a loader equipped with a pallet fork is determined by:
SAE J1197: 50% of full turn static tipping load or hydraulic limit.
CEN EN 474-3: 60% of full turn static tipping load on rough terrain or hydraulic limit.
CEN EN 474-3: 80% of full turn static tipping load on firm and level ground or hydraulic limit.

*SAE - Society of Automotive Engineers
**CEN - European Committee for Standardization

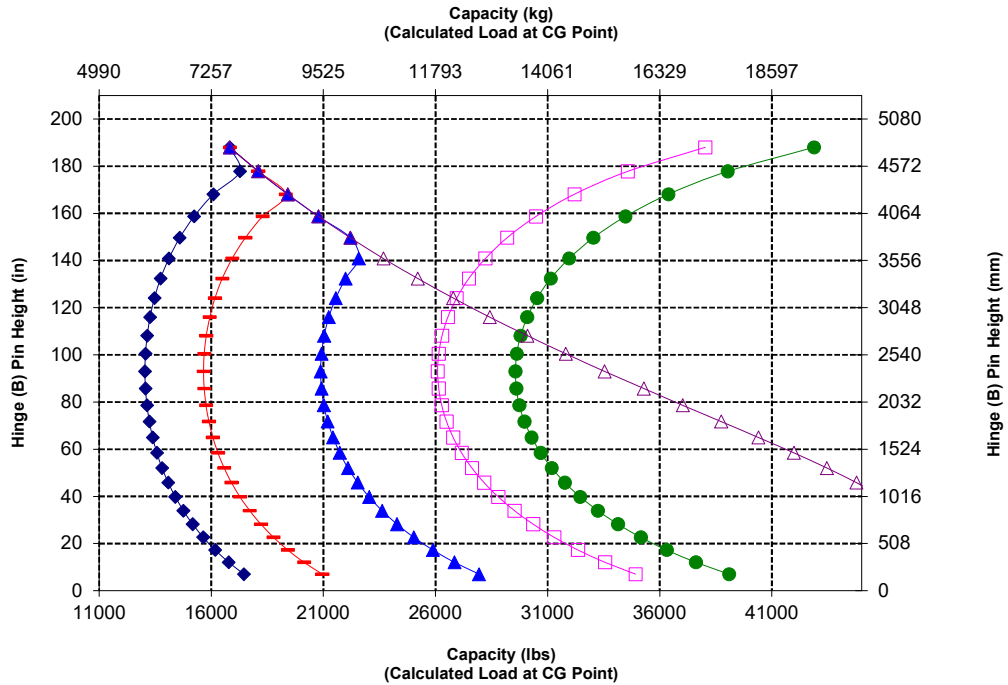

WARNING: Do not exceed tine load capacity. Individual tine capacity is stamped on the side of each tine.

980 Wheel Loader Specifications

Fork Specifications

Fork Specifications

1	Tine Length	mm	2438
		in	96.0
2	Load Center	mm	1219
		in	48.0
	Static Tipping Load - Straight (Forks Level)	kg	12757
		lbs	28117
	Static Tipping Load - Articulated (Forks Level)	kg	11245
		lbs	24783
	Rated Load (SAE J1197 - 50% FTSTL)	kg	5622
		lbs	12392
	Rated Load (CEN EN 474-3 Rough Terrain - 60% FTSTL)	kg	6747
		lbs	14870
	Rated Load (CEN EN 474-3 Firm and Level Ground - 80% FTSTL)	kg	6791
		lbs	14967
3	Maximum Overall Length	mm	11229
		in	442.1
4	Reach with Forks at Ground Level	mm	1378
		in	54.2
5	*Ground to Bottom of Tine at Minimum Height and Fork Level	mm	-94
		in	-3.7
6	Reach with Arms Horizontal and Forks Level	mm	1974
		in	77.7
7	Reach with Fork at Maximum Height	mm	890
		in	35.0
8	Ground to Top of Tine with Arms Horizontal and Fork Level	mm	2103
		in	82.8
9	Ground to Top of Tine at Maximum Height and Fork Level	mm	4593
		in	180.8
10	Overall Height of Fork at Full Lift (top of carriage to ground)	mm	5630
		in	221.6
11	Clearance at Full Lift and Max Dump	mm	2159
		in	85.0
12	Max Discharge Angle from Horizontal	deg	57
13	Overall Carriage Width	mm	2821
		in	111.1
14	Overall Carriage Height	mm	1127
		in	44.4
15	Outside Tine Width (max spread)	mm	2629
		in	103.5
16	Outside Tine Width (min spread)	mm	747
		in	29.4
	Tine Width (single tine)	mm	250.0
		in	9.8
	Tine Thickness	mm	90.0
		in	3.5
	Tine Capacity	kg	15750
		lbs	34713
	Operating Weight	kg	30348
		lbs	66887

*Negative values indicate below grade

980 HL Construction Fork, HD, FUSION 108" Carriage 96" Tine 523-4199 523-4202

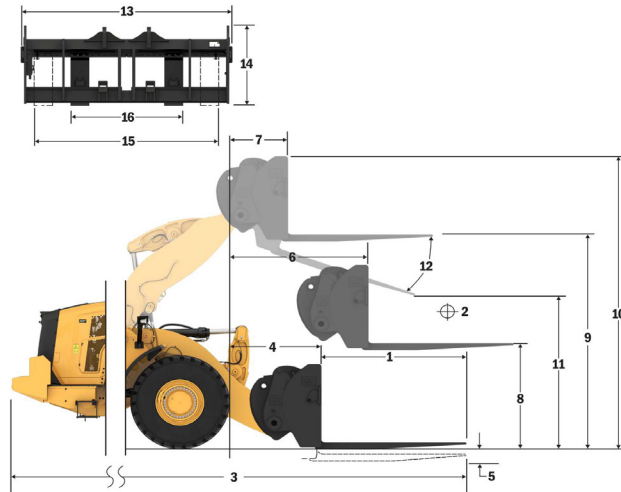

Capacity (kg)
(Calculated Load at CG Point)

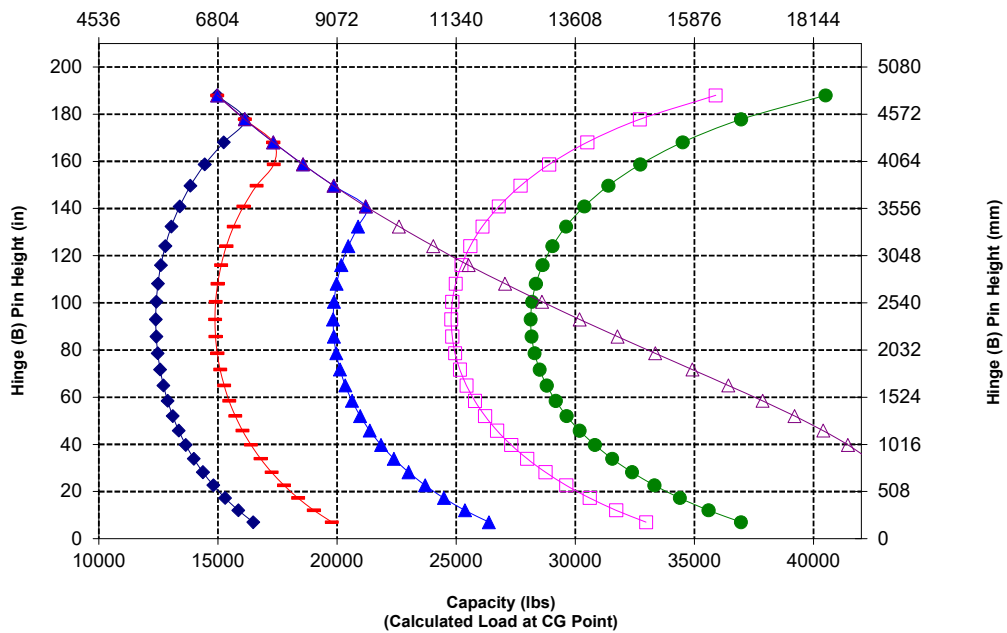

WARNING: Do not exceed tine load capacity. Individual tine capacity is stamped on the side of each tine.

980 Wheel Loader Specifications

Fork Specifications

Fork Specifications

1	Tine Length	mm	1830
		in	72.0
2	Load Center	mm	915
		in	36.0
	Static Tipping Load - Straight (Forks Level)	kq	16622
		lbs	36635
	Static Tipping Load - Articulated (Forks Level)	kq	14453
		lbs	31855
	Rated Load (SAE J1197 - 50% FTSTL)	kq	7227
		lbs	15928
	Rated Load (CEN EN 474-3 Rough Terrain - 60% FTSTL)	kq	8327
		lbs	18352
	Rated Load (CEN EN 474-3 Firm and Level Ground - 80% FTSTL)	kq	8327
		lbs	18352
3	Maximum Overall Length	mm	10445
		in	411.2
4	Reach with Forks at Ground Level	mm	1199
		in	47.2
5	*Ground to Bottom of Tine at Minimum Height and Fork Level	mm	-151
		in	-5.9
6	Reach with Arms Horizontal and Forks Level	mm	1809
		in	71.2
7	Reach with Fork at Maximum Height	mm	883
		in	34.7
8	Ground to Top of Tine with Arms Horizontal and Fork Level	mm	2024
		in	79.7
9	Ground to Top of Tine at Maximum Height and Fork Level	mm	4292
		in	169.0
10	Overall Height of Fork at Full Lift (top of carriage to ground)	mm	5067
		in	199.5
11	Clearance at Full Lift and Max Dump	mm	2676
		in	105.4
12	Max Discharge Angle from Horizontal	deg	45
13	Overall Carriage Width	mm	2217
		in	87.3
14	Overall Carriage Height	mm	840
		in	33.1
15	Outside Tine Width (max spread)	mm	2070
		in	81.5
16	Outside Tine Width (min spread)	mm	470
		in	18.5
	Tine Width (single tine)	mm	150.0
		in	5.9
	Tine Thickness	mm	65.0
		in	2.6
	Tine Capacity	kq	5246
		lbs	11562
	Operating Weight	kq	29722
		lbs	65507

*Negative values indicate below grade

980 AGG

Pallet Fork, FUSION

2x 130 mm HE Tilt Cylinders

87" Carriage 72" Tine

530-1861

530-1869

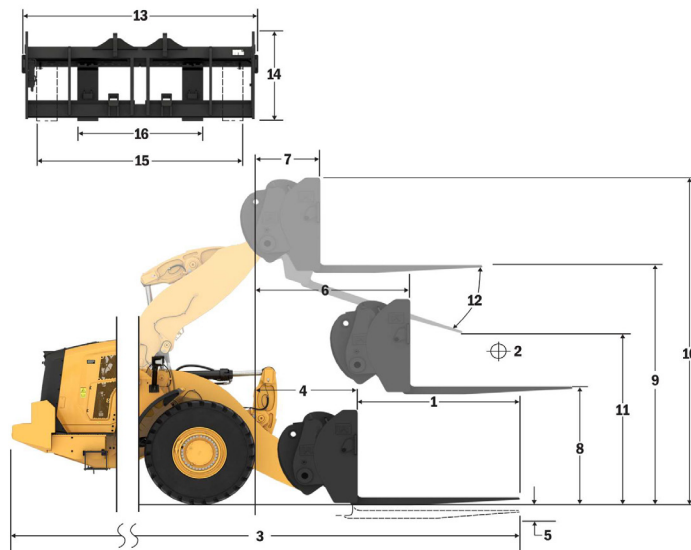

Capacity (kg)
(Calculated Load at CG Point)

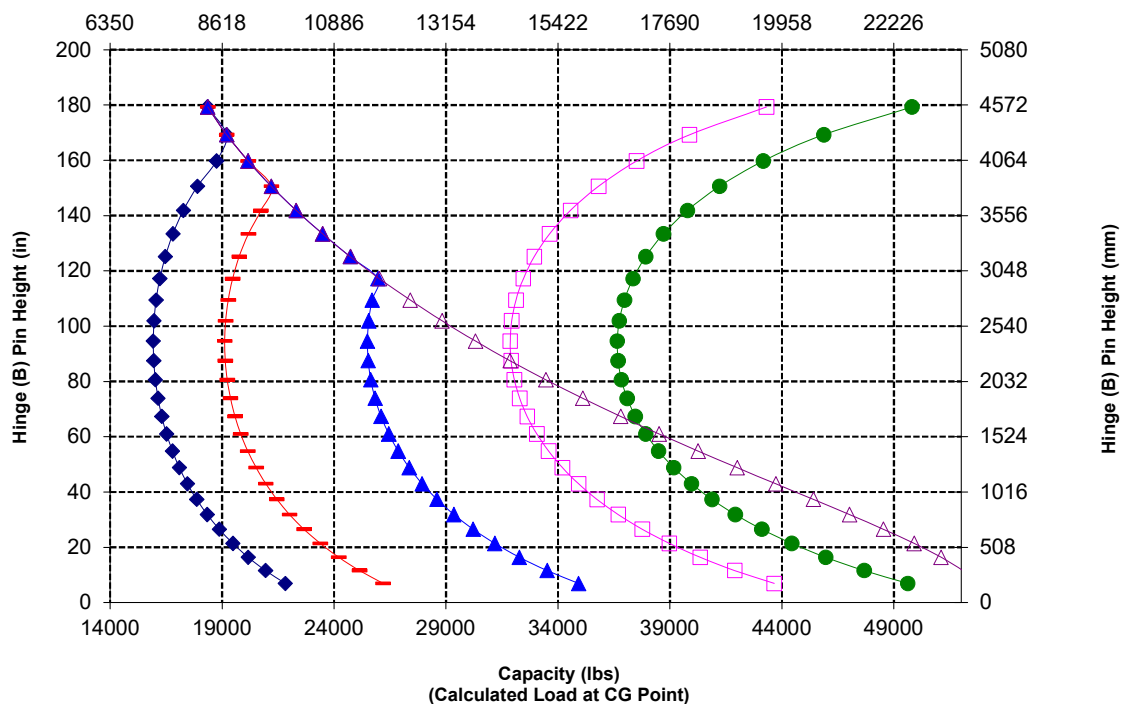

980 Wheel Loader Specifications

Fork Specifications

Fork Specifications

1	Tine Length	mm	1829
		in	72.0
2	Load Center	mm	915
		in	36.0
	Static Tipping Load - Straight (Forks Level)	kg	16347
		lbs	36029
	Static Tipping Load - Articulated (Forks Level)	kg	14170
		lbs	31231
	Rated Load (SAE J1197 - 50% FTSTL)	kg	7085
		lbs	15615
	Rated Load (CEN EN 474-3 Rough Terrain - 60% FTSTL)	kg	8502
		lbs	18738
	Rated Load (CEN EN 474-3 Firm and Level Ground - 80% FTSTL)	kg	8691
		lbs	19155
3	Maximum Overall Length	mm	10387
		in	408.9
4	Reach with Forks at Ground Level	mm	1141
		in	44.9
5	*Ground to Bottom of Tine at Minimum Height and Fork Level	mm	-65
		in	-2.5
6	Reach with Arms Horizontal and Forks Level	mm	1797
		in	70.7
7	Reach with Fork at Maximum Height	mm	870
		in	34.2
8	Ground to Top of Tine with Arms Horizontal and Fork Level	mm	2135
		in	84.0
9	Ground to Top of Tine at Maximum Height and Fork Level	mm	4403
		in	173.4
10	Overall Height of Fork at Full Lift (top of carriage to ground)	mm	5443
		in	214.3
11	Clearance at Full Lift and Max Dump	mm	2597
		in	102.3
12	Max Discharge Angle from Horizontal	deg	51
13	Overall Carriage Width	mm	2833
		in	111.5
14	Overall Carriage Height	mm	1130
		in	44.5
15	Outside Tine Width (max spread)	mm	2483
		in	97.8
16	Outside Tine Width (min spread)	mm	590
		in	23.2
	Tine Width (single tine)	mm	180.0
		in	7.1
	Tine Thickness	mm	90.0
		in	3.5
	Tine Capacity	kg	14800
		lbs	32619
	Operating Weight	kg	30161
		lbs	66474

*Negative values indicate below grade

980 AGG Construction Fork, FUSION

108" Carriage 72" Tine
520-7968 520-7979

*Build 14A
*Parallel Z-Bar Linkage
*Aggregate Handling Configuration

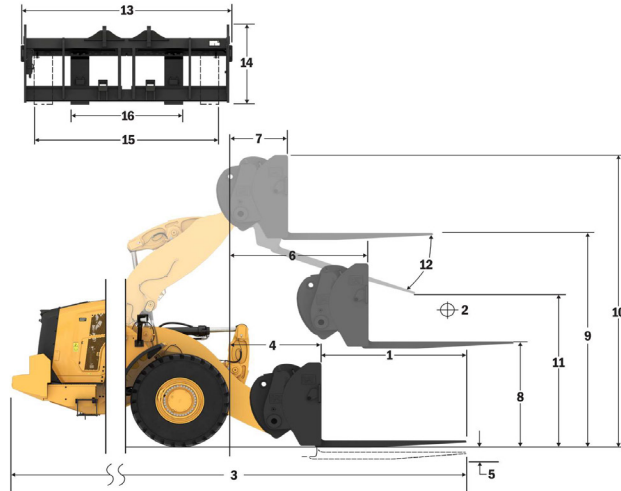

NOTE: Static tipping loads and operating weight are based on the following loader configuration: Bridgestone™ VSTN L4 Tires, Air Conditioning, Ride Control, Powertrain Guard, Full Fluids, Fuel Tank, Coolant, Lubricants, and Operator.

Specifications and ratings conform to the following standards: SAE* J1197, ISO 14397-1, CEN** EN 474-3.

The rated operating load for a loader equipped with a pallet fork is determined by:
SAE J1197: 50% of full turn static tipping load or hydraulic limit.
CEN EN 474-3: 60% of full turn static tipping load on rough terrain or hydraulic limit.
CEN EN 474-3: 80% of full turn static tipping load on firm and level ground or hydraulic limit.

*SAE - Society of Automotive Engineers
**CEN - European Committee for Standardization

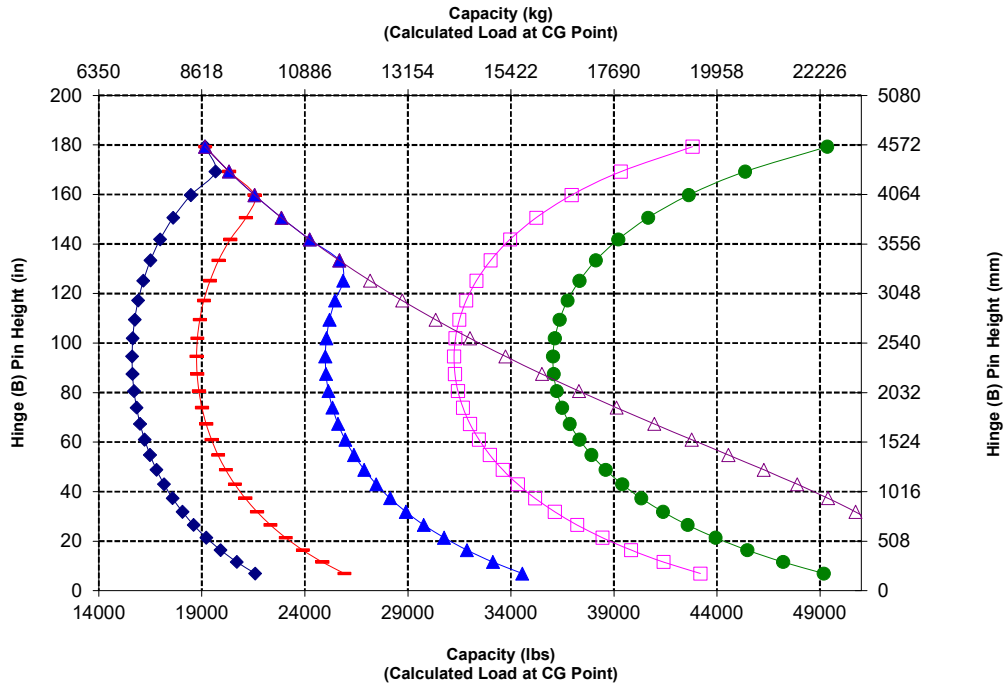

WARNING: Do not exceed tine load capacity. Individual tine capacity is stamped on the side of each tine.

980 Wheel Loader Specifications

Fork Specifications

Fork Specifications

1	Tine Length	mm	2134
		in	84.0
2	Load Center	mm	1067
		in	42.0
	Static Tipping Load - Straight (Forks Level)	kq	15637
		lbs	34463
	Static Tipping Load - Articulated (Forks Level)	kq	13546
		lbs	29855
	Rated Load (SAE J1197 - 50% FTSTL)	kq	6773
		lbs	14927
	Rated Load (CEN EN 474-3 Rough Terrain - 60% FTSTL)	kq	7759
		lbs	17102
	Rated Load (CEN EN 474-3 Firm and Level Ground - 80% FTSTL)	kq	7759
		lbs	17102
3	Maximum Overall Length	mm	10692
		in	420.9
4	Reach with Forks at Ground Level	mm	1141
		in	44.9
5	*Ground to Bottom of Tine at Minimum Height and Fork Level	mm	-65
		in	-2.5
6	Reach with Arms Horizontal and Forks Level	mm	1797
		in	70.7
7	Reach with Fork at Maximum Height	mm	870
		in	34.2
8	Ground to Top of Tine with Arms Horizontal and Fork Level	mm	2135
		in	84.0
9	Ground to Top of Tine at Maximum Height and Fork Level	mm	4403
		in	173.4
10	Overall Height of Fork at Full Lift (top of carriage to ground)	mm	5443
		in	214.3
11	Clearance at Full Lift and Max Dump	mm	2359
		in	92.9
12	Max Discharge Angle from Horizontal	deg	51
13	Overall Carriage Width	mm	2833
		in	111.5
14	Overall Carriage Height	mm	1130
		in	44.5
15	Outside Tine Width (max spread)	mm	2483
		in	97.8
16	Outside Tine Width (min spread)	mm	590
		in	23.2
	Tine Width (single tine)	mm	180.0
		in	7.1
	Tine Thickness	mm	90.0
		in	3.5
	Tine Capacity	kq	12700
		lbs	27991
	Operating Weight	kq	30223
		lbs	66611

*Negative values indicate below grade

980 AGG

Construction Fork, FUSION

108" Carriage

84" Tine

520-7968

520-7986

*Build 14A
*Parallel Z-Bar Linkage
*Aggregate Handling Configuration

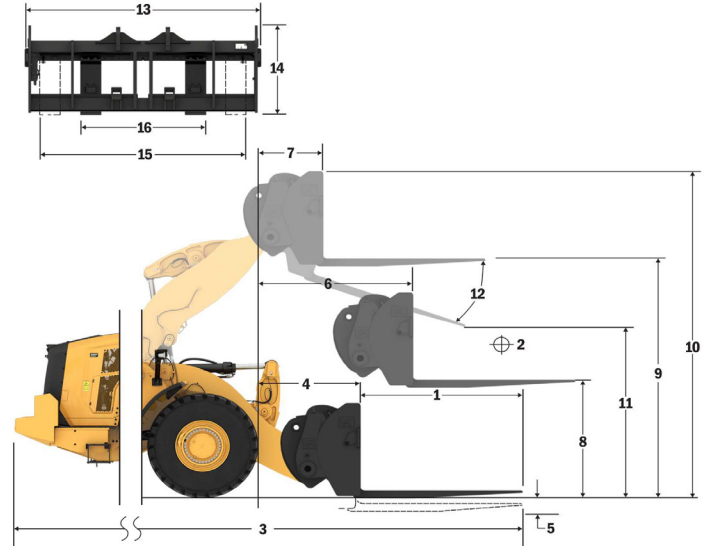

Capacity (kg)
(Calculated Load at CG Point)

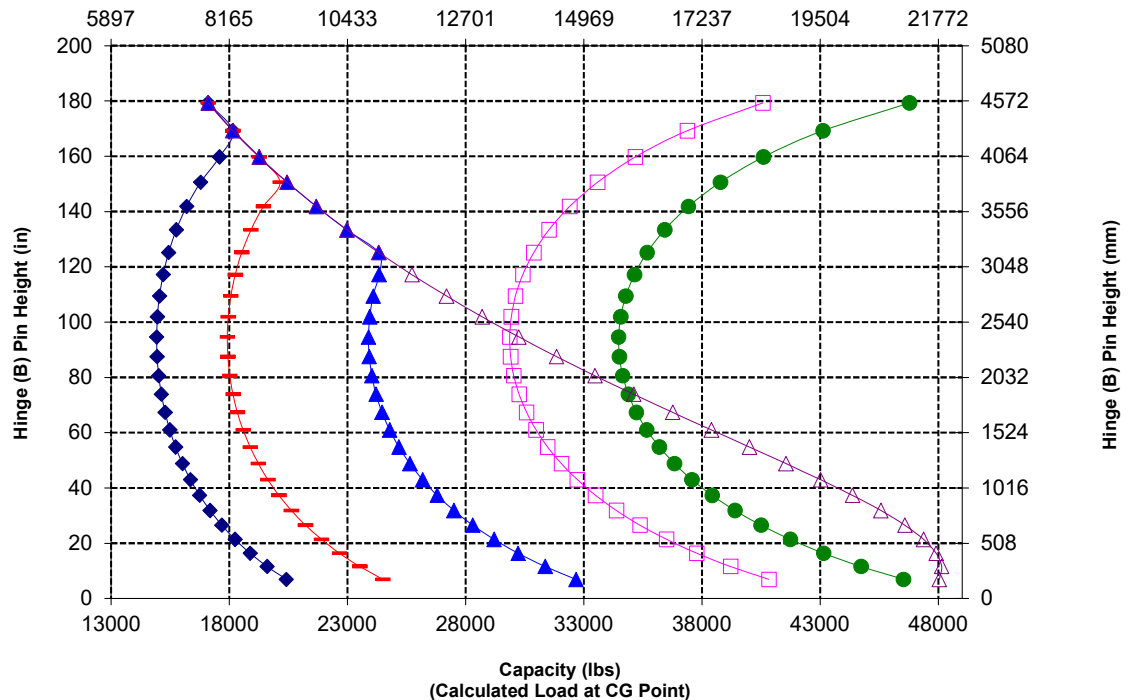

980 Wheel Loader Specifications

Fork Specifications

Fork Specifications

1	Tine Length	mm	2438
		in	96.0
2	Load Center	mm	1219
		in	48.0
	Static Tipping Load - Straight (Forks Level)	kq	14976
		lbs	33008
	Static Tipping Load - Articulated (Forks Level)	kq	12965
		lbs	28575
	Rated Load (SAE J1197 - 50% FTSTL)	kq	6483
		lbs	14288
	Rated Load (CEN EN 474-3 Rough Terrain - 60% FTSTL)	kq	6988
		lbs	15401
	Rated Load (CEN EN 474-3 Firm and Level Ground - 80% FTSTL)	kq	6988
		lbs	15401
3	Maximum Overall Length	mm	10996
		in	432.9
4	Reach with Forks at Ground Level	mm	1141
		in	44.9
5	*Ground to Bottom of Tine at Minimum Height and Fork Level	mm	-65
		in	-2.5
6	Reach with Arms Horizontal and Forks Level	mm	1797
		in	70.7
7	Reach with Fork at Maximum Height	mm	870
		in	34.2
8	Ground to Top of Tine with Arms Horizontal and Fork Level	mm	2135
		in	84.0
9	Ground to Top of Tine at Maximum Height and Fork Level	mm	4403
		in	173.4
10	Overall Height of Fork at Full Lift (top of carriage to ground)	mm	5443
		in	214.3
11	Clearance at Full Lift and Max Dump	mm	2122
		in	83.5
12	Max Discharge Angle from Horizontal	deg	51
13	Overall Carriage Width	mm	2833
		in	111.5
14	Overall Carriage Height	mm	1130
		in	44.5
15	Outside Tine Width (max spread)	mm	2483
		in	97.8
16	Outside Tine Width (min spread)	mm	590
		in	23.2
	Tine Width (single tine)	mm	180.0
		in	7.1
	Tine Thickness	mm	90.0
		in	3.5
	Tine Capacity	kq	11300
		lbs	24905
	Operating Weight	kq	30286
		lbs	66750

*Negative values indicate below grade

980 AGG

Construction Fork, FUSION

108" Carriage

96" Tine

520-7968

520-7981

*Build 14A
*Parallel Z-Bar Linkage
*Aggregate Handling Configuration

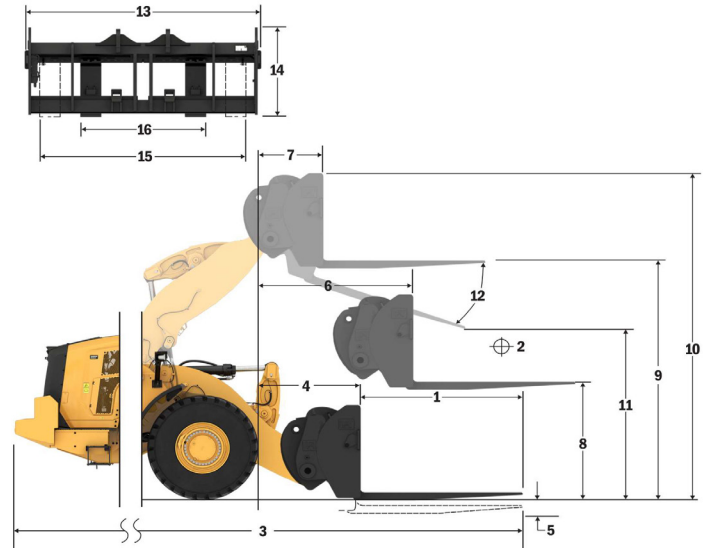

Capacity (kg)
(Calculated Load at CG Point)

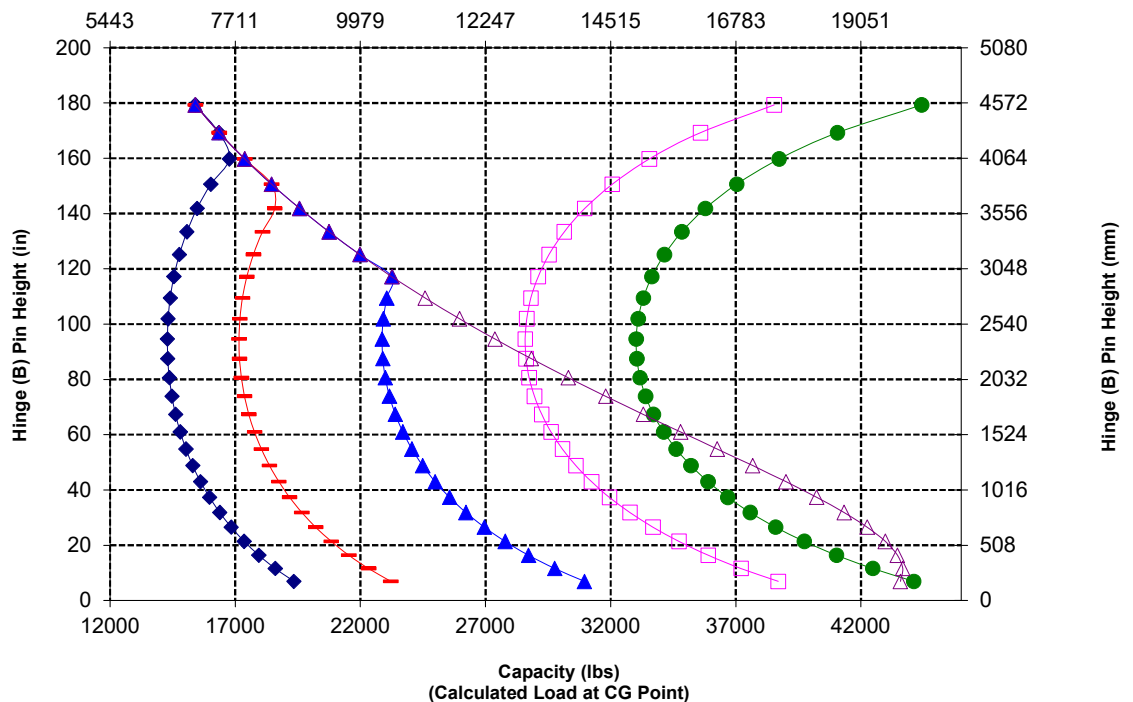

NOTE: Static tipping loads and operating weight are based on the following loader configuration: Bridgestone * VSNT L4 Tires, Air Conditioning, Ride Control, Powertrain Guard, Full Fluids, Fuel Tank, Coolant, Lubricants, and Operator.

Specifications and ratings conform to the following standards: SAE* J1197, ISO 14397-1, CEN** EN 474-3.

The rated operating load for a loader equipped with a pallet fork is determined by:
SAE J1197: 50% of full turn static tipping load or hydraulic limit.
CEN EN 474-3: 60% of full turn static tipping load on rough terrain or hydraulic limit.
CEN EN 474-3: 80% of full turn static tipping load on firm and level ground or hydraulic limit.

*SAE - Society of Automotive Engineers

**CEN - European Committee for Standardization

980 Wheel Loader Specifications

Fork Specifications

Fork Specifications

1	Tine Length	mm	1829
		in	72.0
2	Load Center	mm	914
		in	36.0
	Static Tipping Load - Straight (Forks Level)	kg	16020
		lbs	35309
	Static Tipping Load - Articulated (Forks Level)	kg	13844
		lbs	30513
	Rated Load (SAE J1197 - 50% FTSTL)	kg	6922
		lbs	15256
	Rated Load (CEN EN 474-3 Rough Terrain - 60% FTSTL)	kg	8307
		lbs	18308
	Rated Load (CEN EN 474-3 Firm and Level Ground - 80% FTSTL)	kg	8905
		lbs	19627
3	Maximum Overall Length	mm	10408
		in	409.8
4	Reach with Forks at Ground Level	mm	1162
		in	45.8
5	*Ground to Bottom of Tine at Minimum Height and Fork Level	mm	-99
		in	-3.9
6	Reach with Arms Horizontal and Forks Level	mm	1796
		in	70.7
7	Reach with Fork at Maximum Height	mm	869
		in	34.2
8	Ground to Top of Tine with Arms Horizontal and Fork Level	mm	2095
		in	82.5
9	Ground to Top of Tine at Maximum Height and Fork Level	mm	4364
		in	171.8
10	Overall Height of Fork at Full Lift (top of carriage to ground)	mm	5407
		in	212.9
11	Clearance at Full Lift and Max Dump	mm	2498
		in	98.3
12	Max Discharge Angle from Horizontal	deg	55
13	Overall Carriage Width	mm	2821
		in	111.1
14	Overall Carriage Height	mm	1129
		in	44.4
15	Outside Tine Width (max spread)	mm	2627
		in	103.4
16	Outside Tine Width (min spread)	mm	747
		in	29.4
	Tine Width (single tine)	mm	250.0
		in	9.8
	Tine Thickness	mm	85.0
		in	3.3
	Tine Capacity	kg	18700
		lbs	41215
	Operating Weight	kg	30599
		lbs	67440

*Negative values indicate below grade

980 AGG 2x 130 mm HE Tilt Cylinders
Construction Fork, HD, FUSION 108" Carriage 72" Tine
 523-4199 523-4200

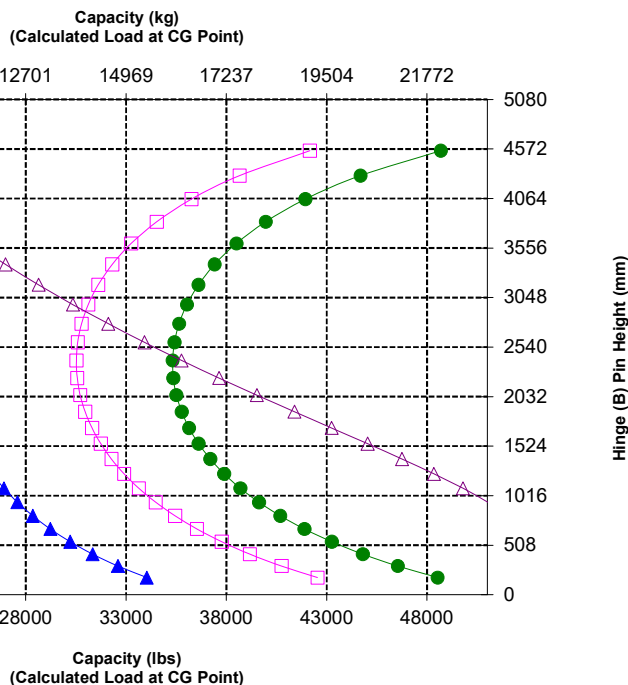
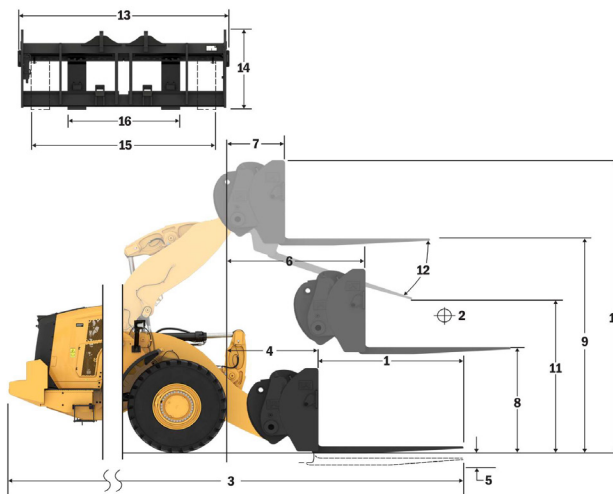

NOTE: Static tipping loads and operating weight are based on the following loader configuration: Bridgestone™ V SNT L4 Tires, Air Conditioning, Ride Control, Powertrain Guard, Full Fluids, Fuel Tank, Coolant, Lubricants, and Operator.

Specifications and ratings conform to the following standards: SAE* J1197, ISO 14397-1, CEN** EN 474-3.

The rated operating load for a loader equipped with a pallet fork is determined by:
 SAE J1197: 50% of full turn static tipping load or hydraulic limit.
 CEN EN 474-3: 60% of full turn static tipping load on rough terrain or hydraulic limit.
 CEN EN 474-3: 80% of full turn static tipping load on firm and level ground or hydraulic limit.

*SAE - Society of Automotive Engineers
 **CEN - European Committee for Standardization



WARNING: Do not exceed tine load capacity. Individual tine capacity is stamped on the side of each tine.

980 Wheel Loader Specifications

Fork Specifications

Fork Specifications

1	Tine Length	mm	2134
		in	84.0
2	Load Center	mm	1067
		in	42.0
	Static Tipping Load - Straight (Forks Level)	kg	15281
		lbs	33680
	Static Tipping Load - Articulated (Forks Level)	kg	13192
		lbs	29075
	Rated Load (SAE J1197 - 50% FTSTL)	kg	6596
		lbs	14537
	Rated Load (CEN EN 474-3 Rough Terrain - 60% FTSTL)	kg	7914
		lbs	17442
	Rated Load (CEN EN 474-3 Firm and Level Ground - 80% FTSTL)	kg	7914
		lbs	17442
3	Maximum Overall Length	mm	10717
		in	421.9
4	Reach with Forks at Ground Level	mm	1166
		in	45.9
5	*Ground to Bottom of Tine at Minimum Height and Fork Level	mm	-99
		in	-3.9
6	Reach with Arms Horizontal and Forks Level	mm	1796
		in	70.7
7	Reach with Fork at Maximum Height	mm	869
		in	34.2
8	Ground to Top of Tine with Arms Horizontal and Fork Level	mm	2100
		in	82.7
9	Ground to Top of Tine at Maximum Height and Fork Level	mm	4369
		in	172.0
10	Overall Height of Fork at Full Lift (top of carriage to ground)	mm	5407
		in	212.9
11	Clearance at Full Lift and Max Dump	mm	2247
		in	88.5
12	Max Discharge Angle from Horizontal	deg	55
13	Overall Carriage Width	mm	2821
		in	111.1
14	Overall Carriage Height	mm	1129
		in	44.4
15	Outside Tine Width (max spread)	mm	2627
		in	103.4
16	Outside Tine Width (min spread)	mm	747
		in	29.4
	Tine Width (single tine)	mm	250.0
		in	9.8
	Tine Thickness	mm	90.0
		in	3.5
	Tine Capacity	kg	17729
		lbs	39075
	Operating Weight	kg	30701
		lbs	67664

*Negative values indicate below grade

980 AGG Construction Fork, HD, FUSION

2x 130 mm HE Tilt Cylinders

108" Carriage 84" Tine

523-4199 523-4201

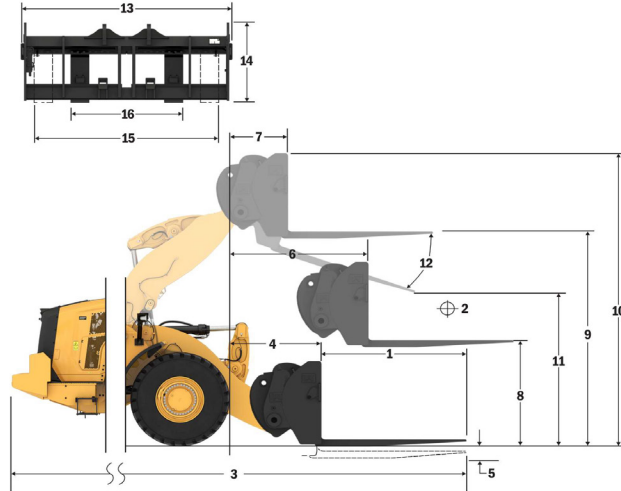

Capacity (kg)
(Calculated Load at CG Point)

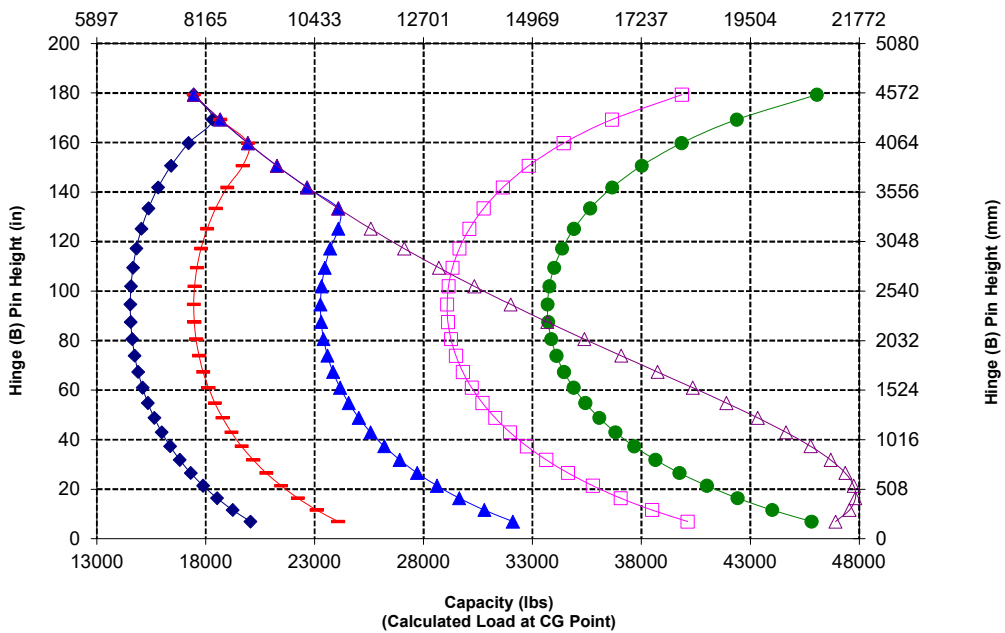

NOTE: Static tipping loads and operating weight are based on the following loader configuration: Bridgestone™ VSNLT L4 Tires, Air Conditioning, Ride Control, Powertrain Guard, Full Fluids, Fuel Tank, Coolant, Lubricants, and Operator.

Specifications and ratings conform to the following standards: SAE™ J1197, ISO 14397-1, CEN** EN 474-3.

The rated operating load for a loader equipped with a pallet fork is determined by:
SAE J1197: 50% of full turn static tipping load or hydraulic limit.
CEN EN 474-3: 60% of full turn static tipping load on rough terrain or hydraulic limit.
CEN EN 474-3: 80% of full turn static tipping load on firm and level ground or hydraulic limit.

*SAE - Society of Automotive Engineers
**CEN - European Committee for Standardization



WARNING: Do not exceed tine load capacity. Individual tine capacity is stamped on the side of each tine.

980 Wheel Loader Specifications

Fork Specifications

Fork Specifications

1	Tine Length	mm	2438
		in	96.0
2	Load Center	mm	1219
		in	48.0
	Static Tipping Load - Straight (Forks Level)	kg	14537
		lbs	32041
	Static Tipping Load - Articulated (Forks Level)	kg	12529
		lbs	27614
	Rated Load (SAE J1197 - 50% FTSTL)	kg	6265
		lbs	13807
	Rated Load (CEN EN 474-3 Rough Terrain - 60% FTSTL)	kg	7041
		lbs	15518
	Rated Load (CEN EN 474-3 Firm and Level Ground - 80% FTSTL)	kg	7041
		lbs	15518
3	Maximum Overall Length	mm	11025
		in	434.1
4	Reach with Forks at Ground Level	mm	1170
		in	46.1
5	*Ground to Bottom of Tine at Minimum Height and Fork Level	mm	-98
		in	-3.8
6	Reach with Arms Horizontal and Forks Level	mm	1801
		in	70.9
7	Reach with Fork at Maximum Height	mm	874
		in	34.4
8	Ground to Top of Tine with Arms Horizontal and Fork Level	mm	2102
		in	82.7
9	Ground to Top of Tine at Maximum Height and Fork Level	mm	4370
		in	172.1
10	Overall Height of Fork at Full Lift (top of carriage to ground)	mm	5407
		in	212.9
11	Clearance at Full Lift and Max Dump	mm	1994
		in	78.5
12	Max Discharge Angle from Horizontal	deg	55
13	Overall Carriage Width	mm	2821
		in	111.1
14	Overall Carriage Height	mm	1127
		in	44.4
15	Outside Tine Width (max spread)	mm	2629
		in	103.5
16	Outside Tine Width (min spread)	mm	747
		in	29.4
	Tine Width (single tine)	mm	250.0
		in	9.8
	Tine Thickness	mm	90.0
		in	3.5
	Tine Capacity	kg	15750
		lbs	34713
	Operating Weight	kg	30852
		lbs	67997

*Negative values indicate below grade

980 AGG
Construction Fork, HD, FUSION

2x 130 mm HE Tilt Cylinders
108" Carriage 96" Tine
523-4199 523-4202

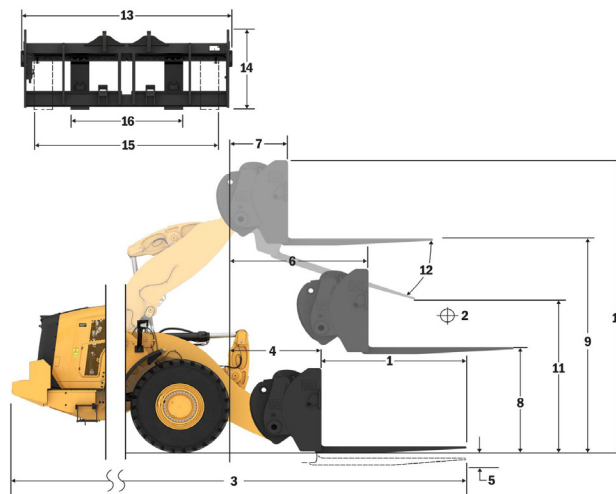

Capacity (kg)
(Calculated Load at CG Point)

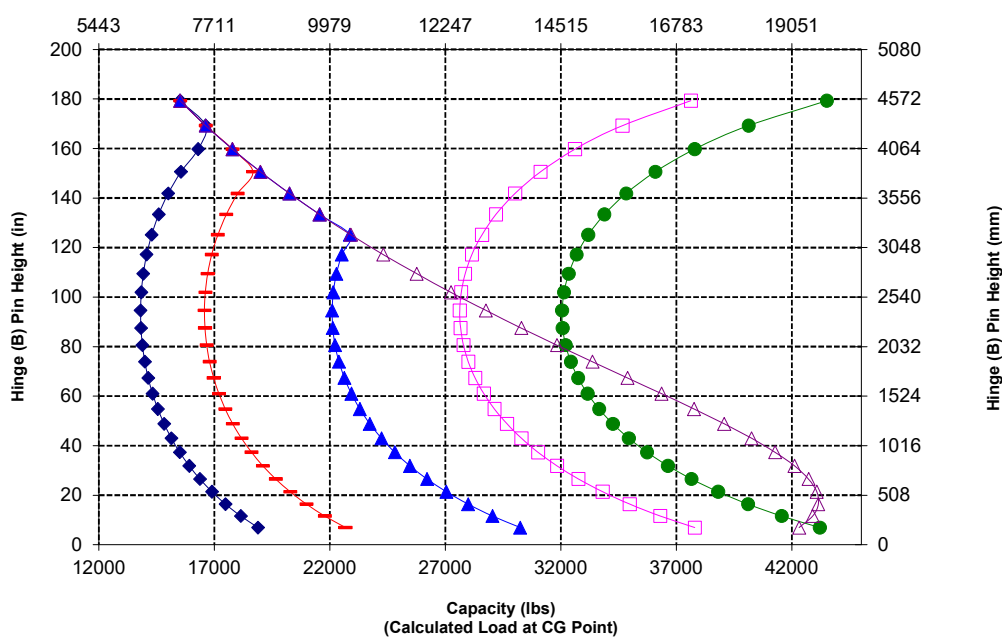

WARNING: Do not exceed tine load capacity. Individual tine capacity is stamped on the side of each tine.

980 Wheel Loader Specifications

Fork Specifications

Fork Specifications

1	Tine Length	mm	1830
		in	72.0
2	Load Center	mm	915
		in	36.0
	Static Tipping Load - Straight (Forks Level)	kg	16621
		lbs	36633
	Static Tipping Load - Articulated (Forks Level)	kg	14453
		lbs	31854
	Rated Load (SAE J1197 - 50% FTSTL)	kg	7226
		lbs	15927
	Rated Load (CEN EN 474-3 Rough Terrain - 60% FTSTL)	kg	8672
		lbs	19112
	Rated Load (CEN EN 474-3 Firm and Level Ground - 80% FTSTL)	kg	11207
		lbs	24701
3	Maximum Overall Length	mm	10445
		in	411.2
4	Reach with Forks at Ground Level	mm	1199
		in	47.2
5	*Ground to Bottom of Tine at Minimum Height and Fork Level	mm	-151
		in	-5.9
6	Reach with Arms Horizontal and Forks Level	mm	1809
		in	71.2
7	Reach with Fork at Maximum Height	mm	883
		in	34.7
8	Ground to Top of Tine with Arms Horizontal and Fork Level	mm	2024
		in	79.7
9	Ground to Top of Tine at Maximum Height and Fork Level	mm	4292
		in	169.0
10	Overall Height of Fork at Full Lift (top of carriage to ground)	mm	5067
		in	199.5
11	Clearance at Full Lift and Max Dump	mm	2676
		in	105.4
12	Max Discharge Angle from Horizontal	deg	45
13	Overall Carriage Width	mm	2217
		in	87.3
14	Overall Carriage Height	mm	840
		in	33.1
15	Outside Tine Width (max spread)	mm	2070
		in	81.5
16	Outside Tine Width (min spread)	mm	470
		in	18.5
	Tine Width (single tine)	mm	150.0
		in	5.9
	Tine Thickness	mm	65.0
		in	2.6
	Tine Capacity	kg	5246
		lbs	11562
	Operating Weight	kg	29772
		lbs	65617

*Negative values indicate below grade

980 AGG QC

Pallet Fork, FUSION

2x 150 mm HE Tilt Cylinders

87" Carriage 72" Tine

530-1861

530-1869

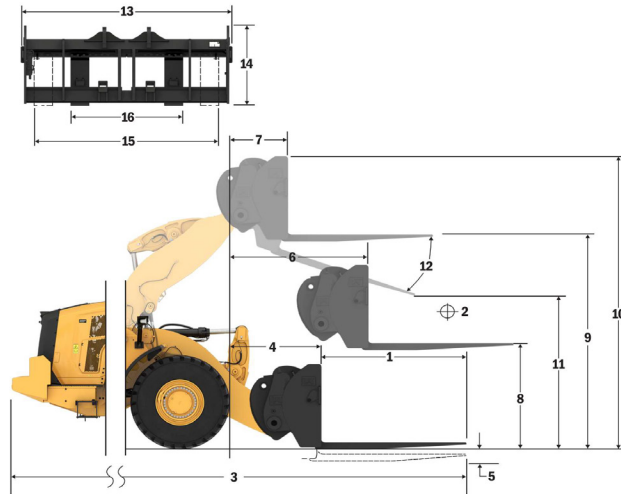

Capacity (kg)
(Calculated Load at CG Point)

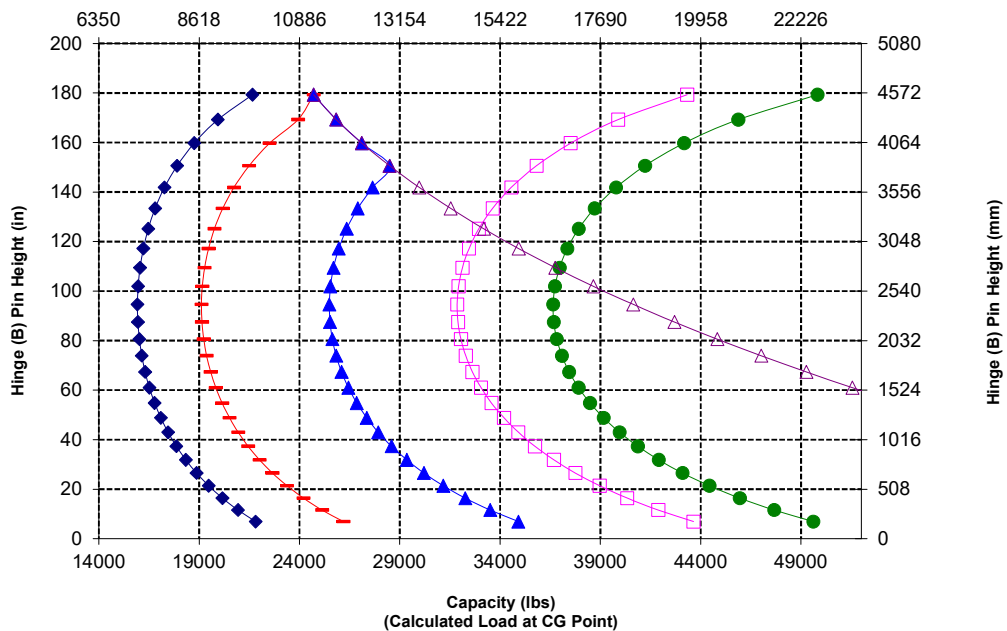

NOTE: Static tipping loads and operating weight are based on the following loader configuration: Bridgestone® VSNLT L4 Tires, Air Conditioning, Ride Control, Powertrain Guard, Full Fluids, Fuel Tank, Coolant, Lubricants, and Operator.

Specifications and ratings conform to the following standards: SAE® J1197, ISO 14397-1, CEN** EN 474-3.

The rated operating load for a loader equipped with a pallet fork is determined by:
SAE J1197: 50% of full turn static tipping load or hydraulic limit.
CEN EN 474-3: 60% of full turn static tipping load on rough terrain or hydraulic limit.
CEN EN 474-3: 80% of full turn static tipping load on firm and level ground or hydraulic limit.

*SAE - Society of Automotive Engineers
**CEN - European Committee for Standardization



WARNING: Do not exceed tine load capacity. Individual tine capacity is stamped on the side of each tine.

Fork Specifications

Fork Specifications

1	Tine Length	mm	1829
		in	72.0
2	Load Center	mm	915
		in	36.0
	Static Tipping Load - Straight (Forks Level)	kg	16347
		lbs	36028
	Static Tipping Load - Articulated (Forks Level)	kg	14169
		lbs	31229
	Rated Load (SAE J1197 - 50% FTSTL)	kg	7085
		lbs	15614
	Rated Load (CEN EN 474-3 Rough Terrain - 60% FTSTL)	kg	8501
		lbs	18737
	Rated Load (CEN EN 474-3 Firm and Level Ground - 80% FTSTL)	kg	11335
		lbs	24983
3	Maximum Overall Length	mm	10387
		in	408.9
4	Reach with Forks at Ground Level	mm	1141
		in	44.9
5	*Ground to Bottom of Tine at Minimum Height and Fork Level	mm	-65
		in	-2.5
6	Reach with Arms Horizontal and Forks Level	mm	1797
		in	70.7
7	Reach with Fork at Maximum Height	mm	870
		in	34.2
8	Ground to Top of Tine with Arms Horizontal and Fork Level	mm	2135
		in	84.0
9	Ground to Top of Tine at Maximum Height and Fork Level	mm	4403
		in	173.4
10	Overall Height of Fork at Full Lift (top of carriage to ground)	mm	5443
		in	214.3
11	Clearance at Full Lift and Max Dump	mm	2597
		in	102.3
12	Max Discharge Angle from Horizontal	deg	51
13	Overall Carriage Width	mm	2833
		in	111.5
14	Overall Carriage Height	mm	1130
		in	44.5
15	Outside Tine Width (max spread)	mm	2483
		in	97.8
16	Outside Tine Width (min spread)	mm	590
		in	23.2
	Tine Width (single tine)	mm	180.0
		in	7.1
	Tine Thickness	mm	90.0
		in	3.5
	Tine Capacity	kg	14800
		lbs	32619
	Operating Weight	kg	30211
		lbs	66585

*Negative values indicate below grade

980 AGG QC

Construction Fork, FUSION

108" Carriage
520-7968

72" Tine
520-7979

*Build 14A
*Parallel Z-Bar Linkage
*150mm HE Tilt Cylinders, for use with FUSION only

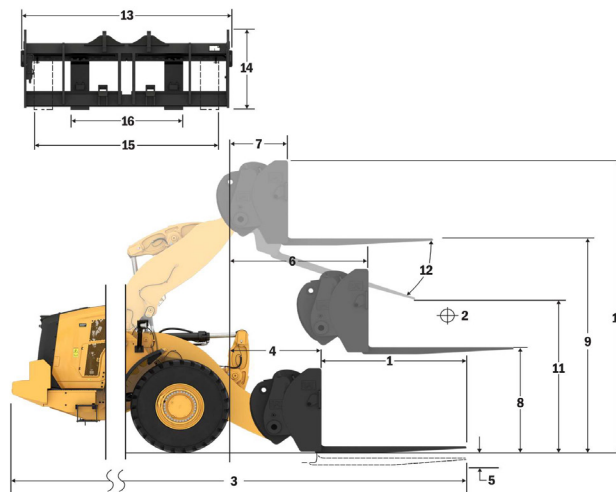

Capacity (kg)
(Calculated Load at CG Point)

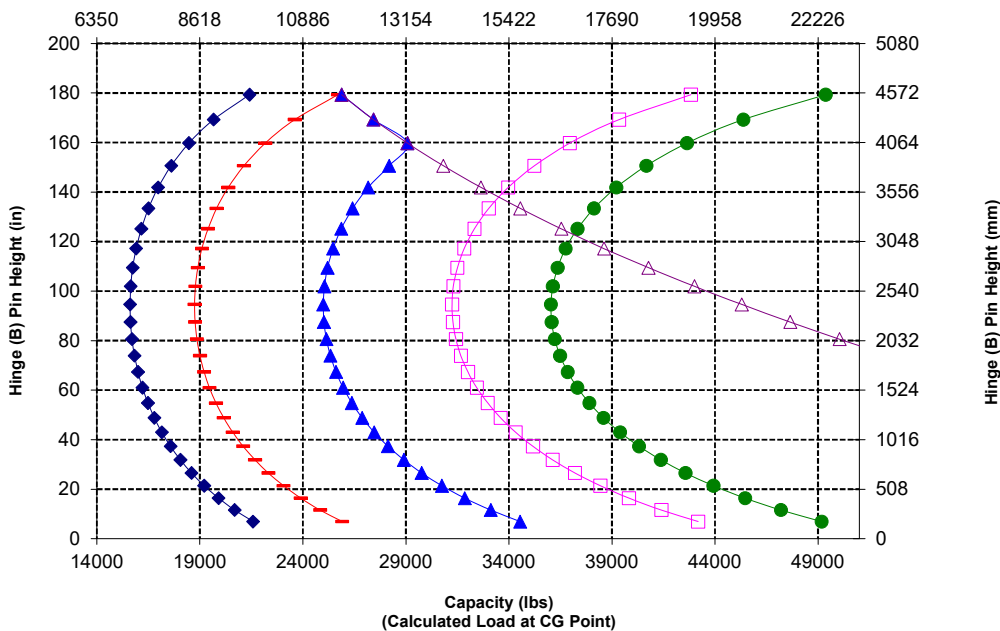

WARNING: Do not exceed tine load capacity. Individual tine capacity is stamped on the side of each tine.

980 Wheel Loader Specifications

Fork Specifications

Fork Specifications

1	Tine Length	mm	2134
		in	84.0
2	Load Center	mm	1067
		in	42.0
	Static Tipping Load - Straight (Forks Level)	kq	15636
		lbs	34462
	Static Tipping Load - Articulated (Forks Level)	kq	13545
		lbs	29853
	Rated Load (SAE J1197 - 50% FTSTL)	kq	6773
		lbs	14927
	Rated Load (CEN EN 474-3 Rough Terrain - 60% FTSTL)	kq	8127
		lbs	17912
	Rated Load (CEN EN 474-3 Firm and Level Ground - 80% FTSTL)	kq	10508
		lbs	23160
3	Maximum Overall Length	mm	10692
		in	420.9
4	Reach with Forks at Ground Level	mm	1141
		in	44.9
5	*Ground to Bottom of Tine at Minimum Height and Fork Level	mm	-65
		in	-2.5
6	Reach with Arms Horizontal and Forks Level	mm	1797
		in	70.7
7	Reach with Fork at Maximum Height	mm	870
		in	34.2
8	Ground to Top of Tine with Arms Horizontal and Fork Level	mm	2135
		in	84.0
9	Ground to Top of Tine at Maximum Height and Fork Level	mm	4403
		in	173.4
10	Overall Height of Fork at Full Lift (top of carriage to ground)	mm	5443
		in	214.3
11	Clearance at Full Lift and Max Dump	mm	2359
		in	92.9
12	Max Discharge Angle from Horizontal	deg	51
13	Overall Carriage Width	mm	2833
		in	111.5
14	Overall Carriage Height	mm	1130
		in	44.5
15	Outside Tine Width (max spread)	mm	2483
		in	97.8
16	Outside Tine Width (min spread)	mm	590
		in	23.2
	Tine Width (single tine)	mm	180.0
		in	7.1
	Tine Thickness	mm	90.0
		in	3.5
	Tine Capacity	kq	12700
		lbs	27991
	Operating Weight	kq	30273
		lbs	66721

*Negative values indicate below grade

980 AGG QC

Construction Fork, FUSION

108" Carriage

84" Tine

520-7968

520-7986

*Build 14A
*Parallel Z-Bar Linkage
*150mm HE Tilt Cylinders, for use with FUSION only

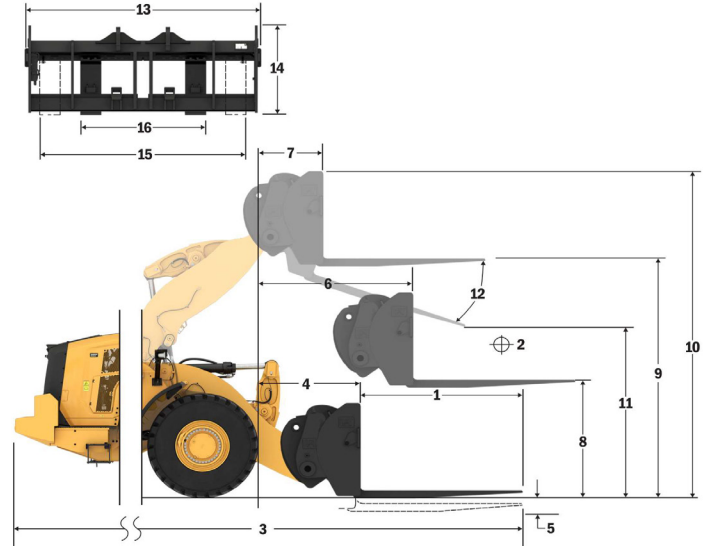

Capacity (kg)
(Calculated Load at CG Point)

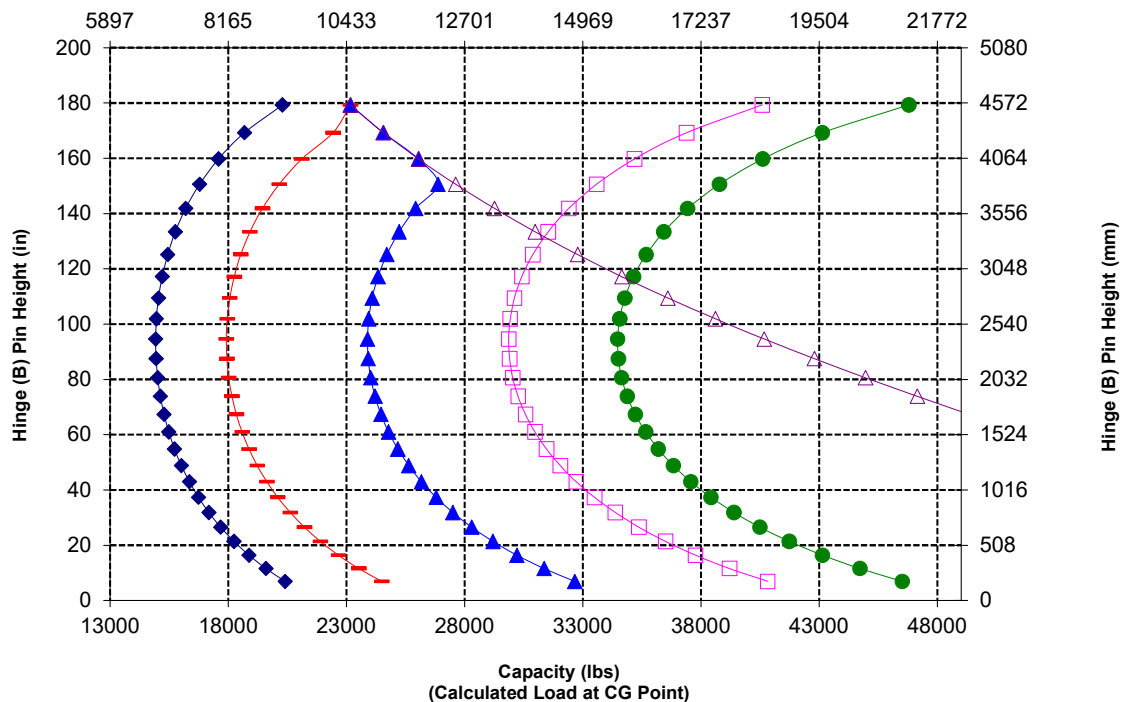

980 Wheel Loader Specifications

Fork Specifications

Fork Specifications

1	Tine Length	mm	2438
		in	96.0
2	Load Center	mm	1219
		in	48.0
	Static Tipping Load - Straight (Forks Level)	kq	14976
		lbs	33007
	Static Tipping Load - Articulated (Forks Level)	kq	12965
		lbs	28574
	Rated Load (SAE J1197 - 50% FTSTL)	kq	6482
		lbs	14287
	Rated Load (CEN EN 474-3 Rough Terrain - 60% FTSTL)	kq	7779
		lbs	17144
	Rated Load (CEN EN 474-3 Firm and Level Ground - 80% FTSTL)	kq	9491
		lbs	20919
3	Maximum Overall Length	mm	10996
		in	432.9
4	Reach with Forks at Ground Level	mm	1141
		in	44.9
5	*Ground to Bottom of Tine at Minimum Height and Fork Level	mm	-65
		in	-2.5
6	Reach with Arms Horizontal and Forks Level	mm	1797
		in	70.7
7	Reach with Fork at Maximum Height	mm	870
		in	34.2
8	Ground to Top of Tine with Arms Horizontal and Fork Level	mm	2135
		in	84.0
9	Ground to Top of Tine at Maximum Height and Fork Level	mm	4403
		in	173.4
10	Overall Height of Fork at Full Lift (top of carriage to ground)	mm	5443
		in	214.3
11	Clearance at Full Lift and Max Dump	mm	2122
		in	83.5
12	Max Discharge Angle from Horizontal	deg	51
13	Overall Carriage Width	mm	2833
		in	111.5
14	Overall Carriage Height	mm	1130
		in	44.5
15	Outside Tine Width (max spread)	mm	2483
		in	97.8
16	Outside Tine Width (min spread)	mm	590
		in	23.2
	Tine Width (single tine)	mm	180.0
		in	7.1
	Tine Thickness	mm	90.0
		in	3.5
	Tine Capacity	kq	11300
		lbs	24905
	Operating Weight	kq	30336
		lbs	66860

*Negative values indicate below grade

980 AGG QC

Construction Fork, FUSION

108" Carriage

96" Tine

520-7968

520-7981

*Build 14A
*Parallel Z-Bar Linkage
*150mm HE Tilt Cylinders, for use with FUSION only

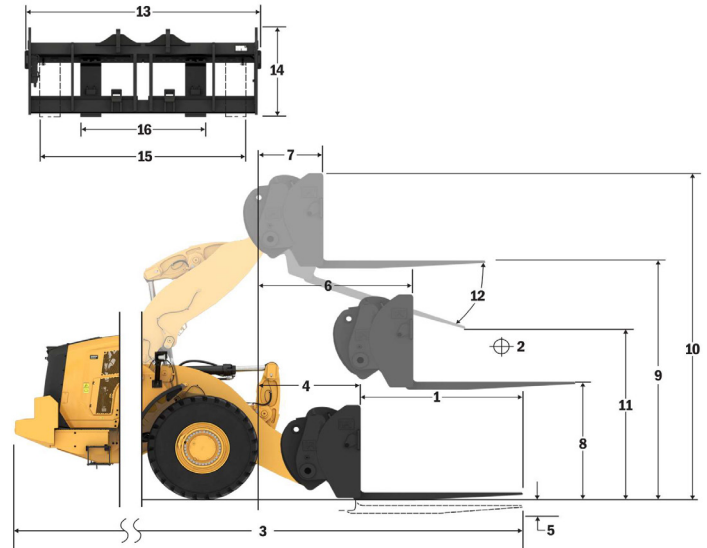

Capacity (kg)
(Calculated Load at CG Point)

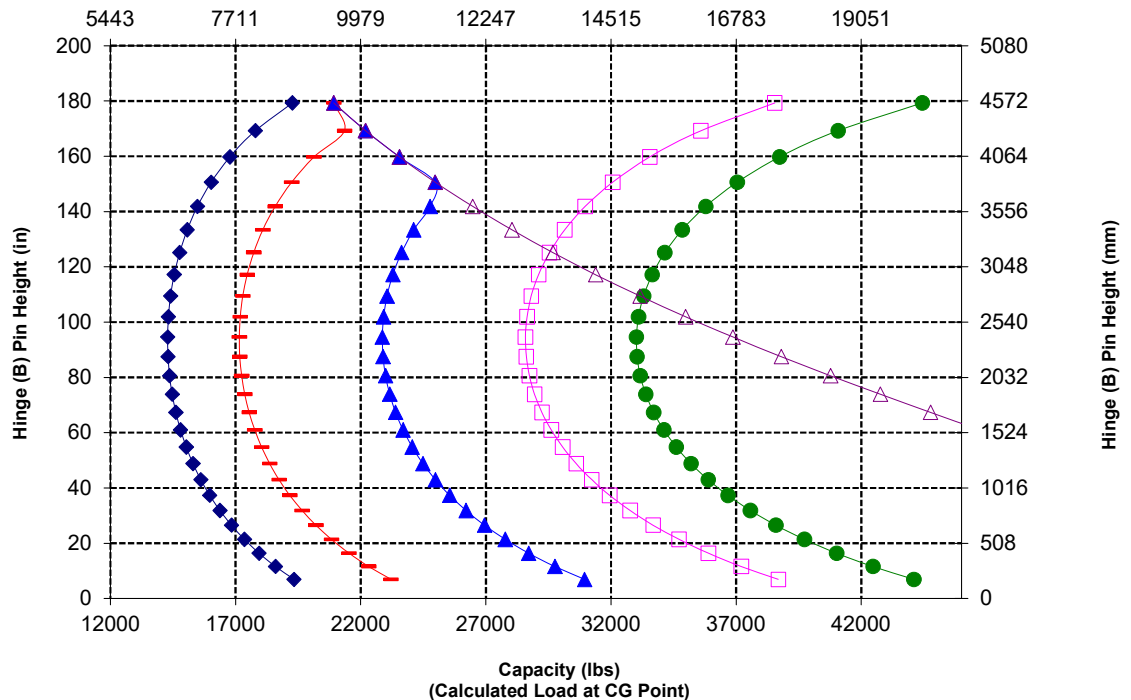

980 Wheel Loader Specifications

Fork Specifications

Fork Specifications

1	Tine Length	mm	1829
		in	72.0
2	Load Center	mm	914
		in	36.0
	Static Tipping Load - Straight (Forks Level)	kq	16020
		lbs	35307
	Static Tipping Load - Articulated (Forks Level)	kq	13843
		lbs	30511
	Rated Load (SAE J1197 - 50% FTSTL)	kq	6922
		lbs	15255
	Rated Load (CEN EN 474-3 Rough Terrain - 60% FTSTL)	kq	8306
		lbs	18307
	Rated Load (CEN EN 474-3 Firm and Level Ground - 80% FTSTL)	kq	11075
		lbs	24409
3	Maximum Overall Length	mm	10408
		in	409.8
4	Reach with Forks at Ground Level	mm	1162
		in	45.8
5	*Ground to Bottom of Tine at Minimum Height and Fork Level	mm	-99
		in	-3.9
6	Reach with Arms Horizontal and Forks Level	mm	1796
		in	70.7
7	Reach with Fork at Maximum Height	mm	869
		in	34.2
8	Ground to Top of Tine with Arms Horizontal and Fork Level	mm	2095
		in	82.5
9	Ground to Top of Tine at Maximum Height and Fork Level	mm	4364
		in	171.8
10	Overall Height of Fork at Full Lift (top of carriage to ground)	mm	5407
		in	212.9
11	Clearance at Full Lift and Max Dump	mm	2498
		in	98.3
12	Max Discharge Angle from Horizontal	deg	55
13	Overall Carriage Width	mm	2821
		in	111.1
14	Overall Carriage Height	mm	1129
		in	44.4
15	Outside Tine Width (max spread)	mm	2627
		in	103.4
16	Outside Tine Width (min spread)	mm	747
		in	29.4
	Tine Width (single tine)	mm	250.0
		in	9.8
	Tine Thickness	mm	85.0
		in	3.3
	Tine Capacity	kq	18700
		lbs	41215
	Operating Weight	kq	30649
		lbs	67550

*Negative values indicate below grade

980 AGG QC

Construction Fork, HD, FUSION

2x 150 mm HE Tilt Cylinders

108" Carriage 72" Tine

523-4199

523-4200

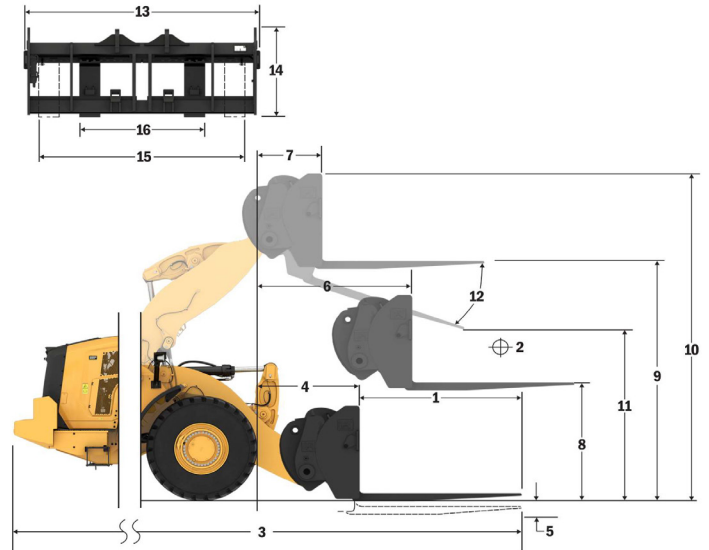

Capacity (kg)
(Calculated Load at CG Point)

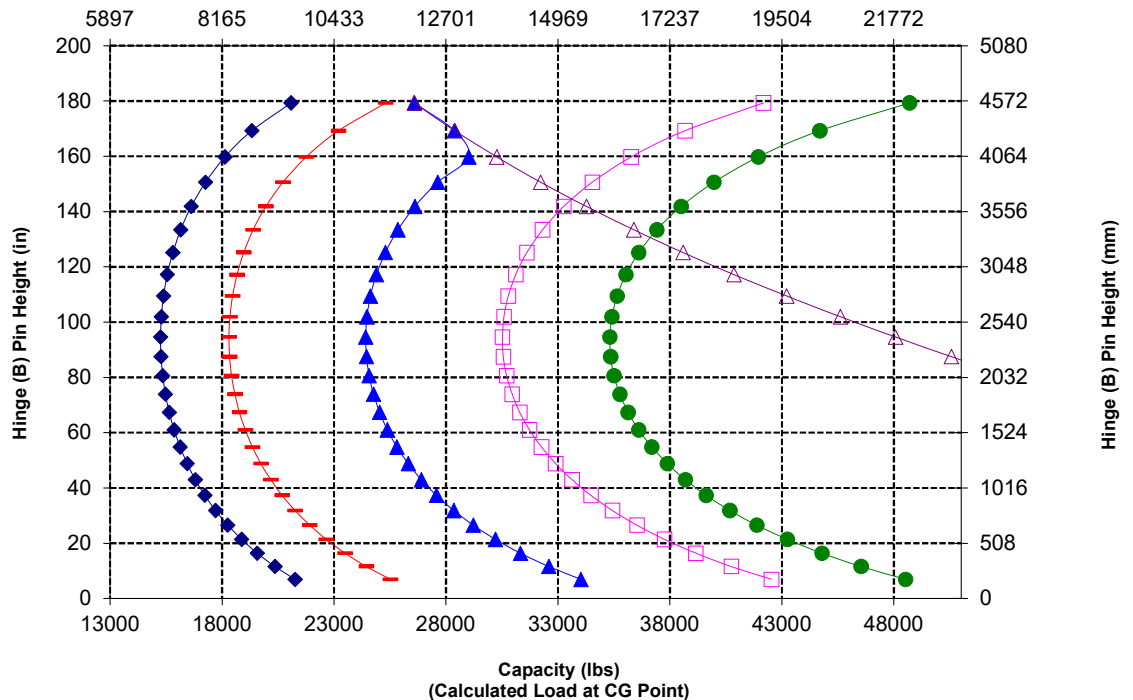

980 Wheel Loader Specifications

Fork Specifications

Fork Specifications

1	Tine Length	mm	2134
		in	84.0
2	Load Center	mm	1067
		in	42.0
	Static Tipping Load - Straight (Forks Level)	kq	15281
		lbs	33678
	Static Tipping Load - Articulated (Forks Level)	kq	13191
		lbs	29073
	Rated Load (SAE J1197 - 50% FTSTL)	kq	6595
		lbs	14536
	Rated Load (CEN EN 474-3 Rough Terrain - 60% FTSTL)	kq	7915
		lbs	17444
	Rated Load (CEN EN 474-3 Firm and Level Ground - 80% FTSTL)	kq	10553
		lbs	23258
3	Maximum Overall Length	mm	10717
		in	421.9
4	Reach with Forks at Ground Level	mm	1166
		in	45.9
5	*Ground to Bottom of Tine at Minimum Height and Fork Level	mm	-99
		in	-3.9
6	Reach with Arms Horizontal and Forks Level	mm	1796
		in	70.7
7	Reach with Fork at Maximum Height	mm	869
		in	34.2
8	Ground to Top of Tine with Arms Horizontal and Fork Level	mm	2100
		in	82.7
9	Ground to Top of Tine at Maximum Height and Fork Level	mm	4369
		in	172.0
10	Overall Height of Fork at Full Lift (top of carriage to ground)	mm	5407
		in	212.9
11	Clearance at Full Lift and Max Dump	mm	2247
		in	88.5
12	Max Discharge Angle from Horizontal	deg	55
13	Overall Carriage Width	mm	2821
		in	111.1
14	Overall Carriage Height	mm	1129
		in	44.4
15	Outside Tine Width (max spread)	mm	2627
		in	103.4
16	Outside Tine Width (min spread)	mm	747
		in	29.4
	Tine Width (single tine)	mm	250.0
		in	9.8
	Tine Thickness	mm	90.0
		in	3.5
	Tine Capacity	kq	17729
		lbs	39075
	Operating Weight	kq	30751
		lbs	67775

*Negative values indicate below grade

980 AGG QC

Construction Fork, HD, FUSION

2x 150 mm HE Tilt Cylinders

108" Carriage 84" Tine

523-4199

523-4201

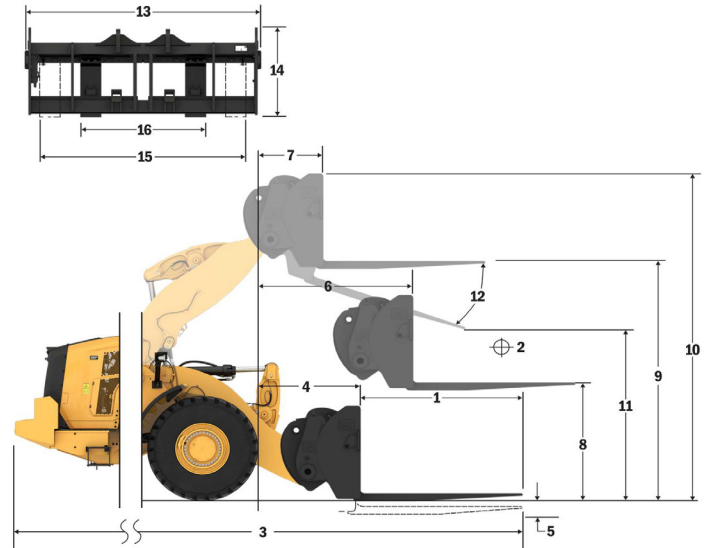

Capacity (kg)
(Calculated Load at CG Point)

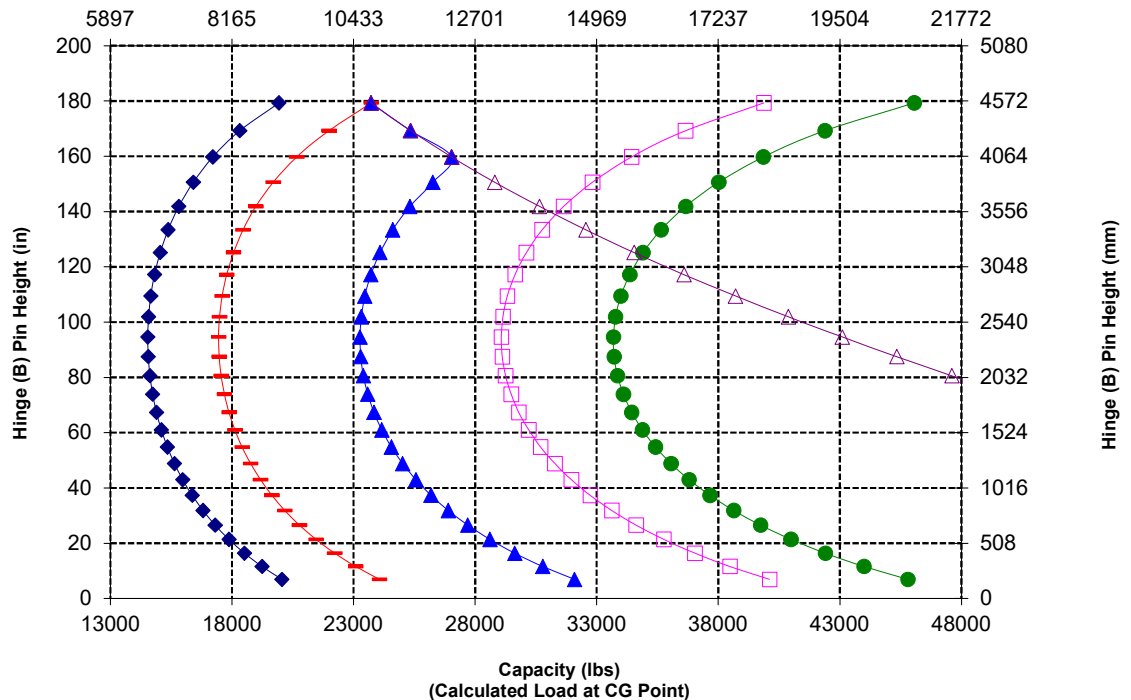

980 Wheel Loader Specifications

Fork Specifications

Fork Specifications

1	Tine Length	mm	2438
		in	96.0
2	Load Center	mm	1219
		in	48.0
	Static Tipping Load - Straight (Forks Level)	kq	14537
		lbs	32039
	Static Tipping Load - Articulated (Forks Level)	kq	12528
		lbs	27612
	Rated Load (SAE J1197 - 50% FTSTL)	kq	6264
		lbs	13806
	Rated Load (CEN EN 474-3 Rough Terrain - 60% FTSTL)	kq	7517
		lbs	16567
	Rated Load (CEN EN 474-3 Firm and Level Ground - 80% FTSTL)	kq	9628
		lbs	21221
3	Maximum Overall Length	mm	11025
		in	434.1
4	Reach with Forks at Ground Level	mm	1170
		in	46.1
5	*Ground to Bottom of Tine at Minimum Height and Fork Level	mm	-98
		in	-3.8
6	Reach with Arms Horizontal and Forks Level	mm	1801
		in	70.9
7	Reach with Fork at Maximum Height	mm	874
		in	34.4
8	Ground to Top of Tine with Arms Horizontal and Fork Level	mm	2102
		in	82.7
9	Ground to Top of Tine at Maximum Height and Fork Level	mm	4370
		in	172.1
10	Overall Height of Fork at Full Lift (top of carriage to ground)	mm	5407
		in	212.9
11	Clearance at Full Lift and Max Dump	mm	1994
		in	78.5
12	Max Discharge Angle from Horizontal	deg	55
13	Overall Carriage Width	mm	2821
		in	111.1
14	Overall Carriage Height	mm	1127
		in	44.4
15	Outside Tine Width (max spread)	mm	2629
		in	103.5
16	Outside Tine Width (min spread)	mm	747
		in	29.4
	Tine Width (single tine)	mm	250.0
		in	9.8
	Tine Thickness	mm	90.0
		in	3.5
	Tine Capacity	kq	15750
		lbs	34713
	Operating Weight	kq	30902
		lbs	68108

*Negative values indicate below grade

980 AGG QC

Construction Fork, HD, FUSION

2x 150 mm HE Tilt Cylinders

108" Carriage 96" Tine

523-4199

523-4202

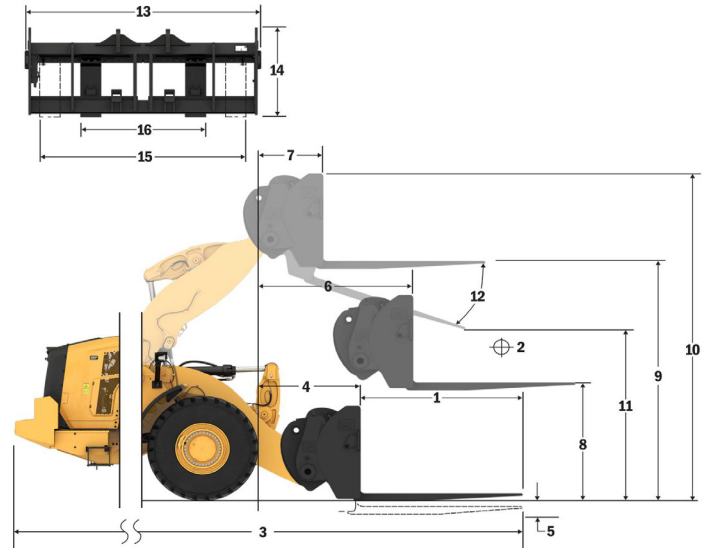

- ◆ Payload (SAE J1197)
- Payload (CEN EN 474-3 - Rough Terrain)
- ▲ Payload (CEN EN 474-3 - Firm & Level)
- Static Tipping Load - Articulated
- Static Tipping Load - Straight
- ▲ Hydraulic TR Capacity
- Hydraulic LR Capacity

NOTE: Static tipping loads and operating weight are based on the following loader configuration: Bridgestone * VSNT L4 Tires, Air Conditioning, Ride Control, Powertrain Guard, Full Fluids, Fuel Tank, Coolant, Lubricants, and Operator.

Specifications and ratings conform to the following standards: SAE* J1197, ISO 14397-1, CEN** EN 474-3.

The rated operating load for a loader equipped with a pallet fork is determined by:
 SAE J1197: 50% of full turn static tipping load or hydraulic limit.
 CEN EN 474-3: 60% of full turn static tipping load on rough terrain or hydraulic limit.
 CEN EN 474-3: 80% of full turn static tipping load on firm and level ground or hydraulic limit.

*SAE - Society of Automotive Engineers
 **CEN - European Committee for Standardization

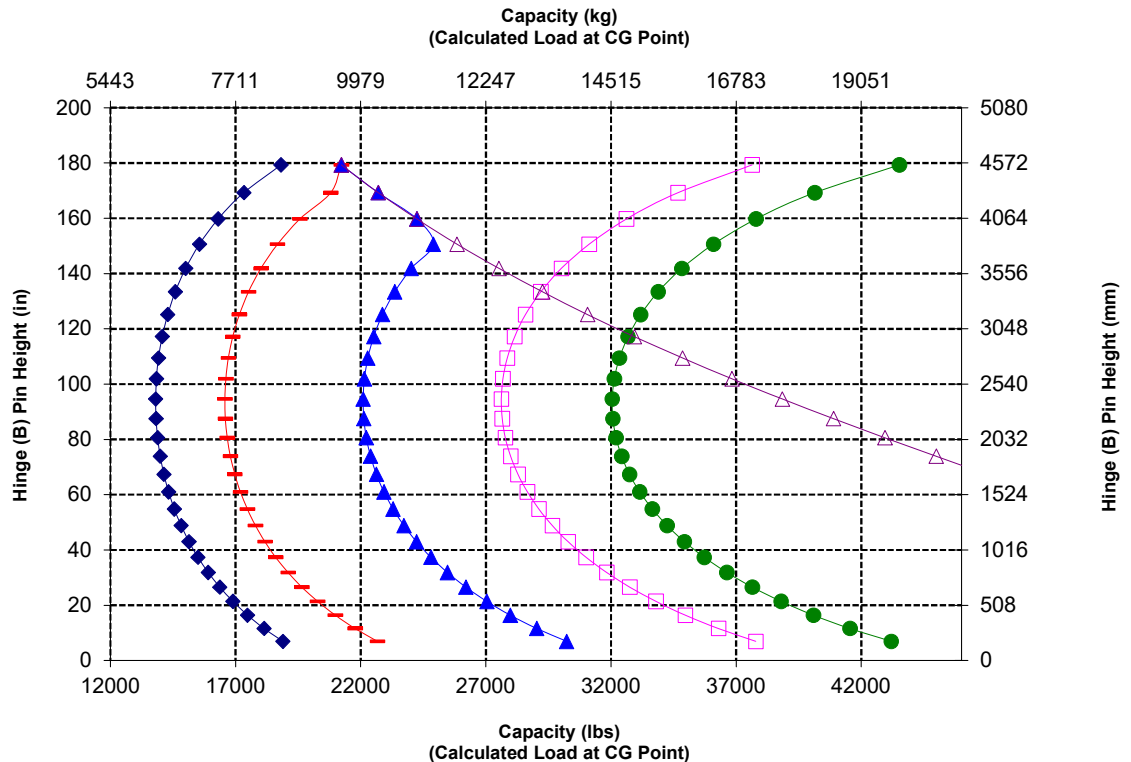

Standard and Optional Equipment

Standard and optional equipment may vary. Consult your Cat dealer for details.

	Standard	Optional		Standard	Optional
OPERATOR ENVIRONMENT			HYDRAULICS		
Cab, pressurized, sound suppression	✓		Implement system, load sensing with variable displacement piston pump	✓	
Door, remote opening system	✓		Steering system, load sensing with dedicated variable displacement piston pump	✓	
EH implement controls, parking brake	✓		Ride control, dual accumulators	✓	
Footrest		✓	3 rd auxiliary function with ride control		✓
HMU steering wheel		✓	Oil sampling valves, Cat XT™ hoses	✓	
Steering, joystick	✓		Quick coupler control		✓
Implement joystick (2V, 3V only)		✓	POWERTRAIN		
Seat belt, monitored	✓		Cat C13 engine	✓	
Entertainment radio (FM, AM, USB, Bluetooth®)		✓	Electric fuel priming pump	✓	
Entertainment radio (DAB+)		✓	Fuel-water separator and secondary fuel filter	✓	
CB radio ready		✓	Engine, air precleaner	✓	
Seat, cloth, air suspension	✓		Turbine, air precleaner		✓
Seat, suede/cloth, air suspension, heated		✓	Radiator, high debris		✓
Seat, leather/cloth, air suspension, heated/cooled		✓	Cooling fan, reversible		✓
Touchscreen display	✓		Axles, open differentials	✓	
Keypad, programmable buttons	✓		Axles, limited slip differential(s)		✓
Mirrors, heated		✓	Axles, ecology drains, AOC ready, extreme temperature seals		✓
Air conditioner, heater, defroster (auto temp, fan)	✓		Axles, oil cooler		✓
Sun visor, front, retractable	✓		Transmission, planetary, automatic power shift	✓	
Sun visor, rear, retractable	✓		Torque converter with lock-up	✓	
Windows, front, safety laminated rounded glass	✓		Heavy-duty transmission		✓
Windows, front, heavy-duty, or full guards		✓	Service brakes, hydraulic, fully enclosed wet disc, wear indicators	✓	
ON-BOARD TECHNOLOGIES			Integrated Braking System (IBS)	✓	
Autodig with Auto Set Tires	✓		Park brake, caliper on front axles, spring applied-pressure released	✓	
Operator ID & machine security	✓		Brake pedal neutralizer with decel function	✓	
Application Profiles	✓		ELECTRICAL		
Job Aids	✓		Starting and charging system, 24V	✓	
Controls Help and eOMM*	✓		Starter, electric, heavy-duty	✓	
Cat Payload Scale	✓		Cold start, 120V or 240V		✓
Cat Advanced Payload		✓	Lights: halogen, 4 work lights, 2 front roading lights with turn signals, 2 rearview lights	✓	
Cat Payload Printer with E-ticket		✓	Lights: LED		✓
Key Features Inform	✓				
Bucket Carry Display Widget	✓				
Remote Flash	✓				

(continued on next page)

* Not available in all languages

** Standard where mandated

*** Not Compatible with roading arrangements

980 Wheel Loader Specifications

Standard and Optional Equipment *(continued)*

Standard and optional equipment may vary. Consult your Cat dealer for details.

	Standard	Optional		Standard	Optional
MONITORING SYSTEM			SAFETY		
Front dash with analog gauges, LCD display, and warning lights	✓		Cat Detect rear radar system		✓
Primary touchscreen monitor (Cat Payload, quad screens, machine settings & messages)	✓		Dedicated rearview screen		✓
Tire Pressure Monitor		✓	Visibility: mirrors, rearview camera	✓	
Maintenance Reminders	✓		Multiview (360°) vision system		✓
LINKAGE			Window cleaning platform, front	✓	
Standard lift, Z-bar	✓		4-Point seat belt retractor		✓
High lift, Z-bar		✓	Reversing strobe lights***		✓
Kickouts: lift and tilt	✓		Seat belt monitoring beacon		✓
ADDITIONAL EQUIPMENT			Secondary steering system, electrical**		✓
Cat Autolube system		✓	Wheel chocks		✓
Fenders, extensions or roading		✓	Warning beacon		✓
Guards: powertrain, crankcase, cab, cylinders, rear		✓	SPECIAL CONFIGURATIONS		
Biodegradable hydraulic oil		✓	Aggregate handler		✓
High-speed oil change system		✓	Waste and scrap		✓
Rear cab access		✓	Forestry		✓
Fast fill fuel tank		✓	Steel mill		✓
Toolbox		✓	Block handler		✓

* Not available in all languages

** Standard where mandated

*** Not Compatible with roading arrangements

The following information applies to the machine at the time of final manufacture as configured for sale in the regions covered in this document. The content of this declaration is valid as of the date issued; however, content related to machine features and specifications are subject to change without notice. For additional information, please see the machine's Operation and Maintenance Manual.

For more information on sustainability in action and our progress, please visit <https://www.caterpillar.com/en/company/sustainability.html>.

Engine

- The Cat® C13 engine meets U.S. EPA Tier 4 Final, EU Stage V, Korea Stage V, China Nonroad Stage IV and Japan 2014 emission standards.
- Cat diesel engines are required to use ULSD (ultra-low sulfur diesel fuel with 15 ppm of sulfur or less) or ULSD blended with the following lower-carbon intensity fuels** up to:
 - ✓ 20% biodiesel FAME (fatty acid methyl ester)*
 - ✓ 100% renewable diesel, HVO (hydrotreated vegetable oil) and GTL (gas-to-liquid) fuels
 Refer to guidelines for successful application. Please consult your Cat dealer or "Caterpillar Machine Fluids Recommendations" (SEBU6250) for details.

* Engines with no aftertreatment devices can use higher blends, up to 100% biodiesel.

** Tailpipe greenhouse gas emissions from lower-carbon intensity fuels are essentially the same as traditional fuels.

Air Conditioning System

The air conditioning system on this machine contains the fluorinated greenhouse gas refrigerant R134a (Global Warming Potential = 1430). The system contains 1.6 kg (3.52 lb) of refrigerant, which has a CO₂ equivalent of 2.288 metric tonnes (2.522 tons).

Paint

- Based on best available knowledge, the maximum allowable concentration, measured in parts per million (PPM), of the following heavy metals in paint are:
 - Barium < 0.01%
 - Cadmium < 0.01%
 - Chromium < 0.01%
 - Lead < 0.01%

Sound Performance

Operator Sound Pressure Level (ISO 6396:2008)	72 dB(A)
Exterior Sound Power Level (ISO 6395:2008)	112 dB(A)
Operator Sound Pressure Level (ISO 6396:2008)*	72 dB(A)
Exterior Sound Power Level (ISO 6395:2008)**	109 dB(A)

*Including countries that adopt the EU and UK Directives

**EU Noise Directive 2000/14/EC and UK Noise Regulation 2001 No. 1701

Oils and Fluids

- Caterpillar factory fills with ethylene glycol coolants. Cat Diesel Engine Antifreeze/Coolant (DEAC) and Cat Extended Life Coolant (ELC) can be recycled. Consult your Cat dealer for more information.
- Cat Bio HYDO™ Advanced is an EU Ecolabel approved biodegradable hydraulic oil.
- Additional fluids are likely to be present, please consult the Operations and Maintenance Manual or the Application and Installation guide for complete fluid recommendations and maintenance intervals.

Features and Technology

- The following features and technology may contribute to fuel savings and/or carbon reduction. Features may vary. Consult your Cat dealer for details.
 - Autodig with Auto Set Tires provides consistent high bucket fill factors for up to 10% more productivity
 - Powershift transmission with lock-up clutch increases fuel efficiency while delivering optimal performance
 - Automatic engine idle shutdown system reduces idle hours
 - Extended maintenance intervals reduce fluid and filter consumption
 - Remote Flash and Remote Troubleshoot

Recycling

- The materials included in machines are categorized as below with approximate weight percentage. Because of variations of product configurations, the following values in the table may vary.

Material Type	Weight Percentage
Steel	64.23%
Iron	15.93%
Nonferrous Metal	2.54%
Mixed Metal	0.41%
Mixed-Metal and Nonmetal	0.03%
Plastic	0.61%
Rubber	9.92%
Mixed Nonmetallic	0.02%
Fluid	1.74%
Other	3.77%
Uncategorized	0.81%
Total	100%

- A machine with higher recyclability rate will ensure more efficient usage of valuable natural resources and enhance End-of-Life value of the product. According to ISO 16714 (Earthmoving machinery – Recyclability and recoverability – Terminology and calculation method), recyclability rate is defined as percentage by mass (mass fraction in percent) of the new machine potentially able to be recycled, reused or both.

All parts in the bill of material are first evaluated by component type based on a list of components defined by the ISO 16714 and Japan CEMA (Construction Equipment Manufacturers Association) standards. Remaining parts are further evaluated for recyclability based on material type.

Because of variations of product configurations, the following value in the table may vary.

Recyclability – 98%



980

Waste & Scrap Handler

Waste and scrap handler models feature guarding and reinforcement necessary for work in transfer stations, recycling depots, scrap yards, and demolition sites.

Proven Reliability

- Cat C13 engine offers increased power density with a combination of proven electronic fuel and air systems.
- Thorough component design and machine validation processes result in unmatched reliability and uptime.

Durability

- Waste and scrap handler package adds additional steel guards all around the machine to protect your investment and keep debris out of the implement valve and engine compartments.
- Heavy-duty steel cable lower steps stand up to the harshest of conditions.
- Heavy-duty transmission and axles designed to handle extreme applications.
- Automatic planetary powershift (4F/4R) transmission features durable, long-lasting components.

Superior Fuel Efficiency & Productivity

- Optional high lift linkage provides additional dump clearance.
- Optional 3rd valve hydraulics for work tools with a top clamp.
- Optional variable pitch fan and high debris cooling cores keep the cores free from debris.
- Powershift transmission with lock-up clutch increases fuel efficiency while delivering optimal performance.
- Single clutch and lock-to-lock shifting for faster acceleration and speed on grades.
- Automatic idle engine shutdown system significantly reduces idle time, overall operating hours, and fuel consumption.
- Optional limited slip differentials increase traction and reduce tire slip, lowering operating costs.
- Deeply integrated engine, power train, and hydraulic systems deliver unmatched productivity and fuel efficiency.

Safety Features

- Rearview camera enhances visibility behind the machine, helping you work safely and confidently.
- Optional multiview (360°) vision system helps the operator monitor the surroundings of the machine at all times.
- Optional Cat Detect radar technology enhances awareness by monitoring the working environment and alerts operators to hazards.
- Cab access with wide door, optional remote door opening, and stair-like steps add solid stability.
- Floor-to-ceiling windshield, large mirrors with integrated spot mirrors, and rearview camera provide industry leading all-around visibility.

Reduced Maintenance Time and Costs

- Extended fluid and filter change intervals reduce maintenance costs by up to 20%.
- Optional turbine engine air precleaner improves air filter life.
- Remote Troubleshoot can connect the machine to the dealer service department to help diagnose problems quickly so you can get back to work.
- Remote Flash works around your schedule to ensure your machine's software is up to date for optimal performance.
- The Cat App helps you manage fleet location, hours, and maintenance schedules; it also alerts you for required maintenance and allows you to request service from your local Cat dealer.
- One-piece tilting hood makes engine compartment access fast and easy.

Work in Comfort in the All New Cab

- Carbon cab air filter reduces cabin odors.
- Optional powered cabin precleaner filters the incoming air and pressurize the cab.
- Next-generation, easily adjustable seat and suspension for improved operator comfort. It comes in three trim levels and can be equipped with a 4-point harness.
- New in-cab dashboard and high-resolution touch display(s) are easy to use, intuitive, and user friendly.
- Sound suppression, seals, and viscous cab mounts decrease noise and vibration for a quieter work environment.
- The seat-mounted electro-hydraulic joystick steering system provides precision control and dramatically reduces arm fatigue, resulting in excellent comfort and accuracy. An HMU steering wheel is also available.

980 Waste & Scrap Handler Specifications

980 Waste & Scrap Handler Specifications

1. Optional window guarding to provide impact resistance to the glass
2. Added steel guards include crankcase, power train, front frame, hitch, steering cylinder, service center, cab, platform, implement valve cover, and tilt cylinder
3. Carbon cab air filter removes harsh odors
4. Optional powered cab precleaner helps to improve cab filter life and keeps the cab pressurized
5. Optional 3rd valve hydraulics available to control a work tool with a top clamp.
6. Large line of waste and scrap work tools

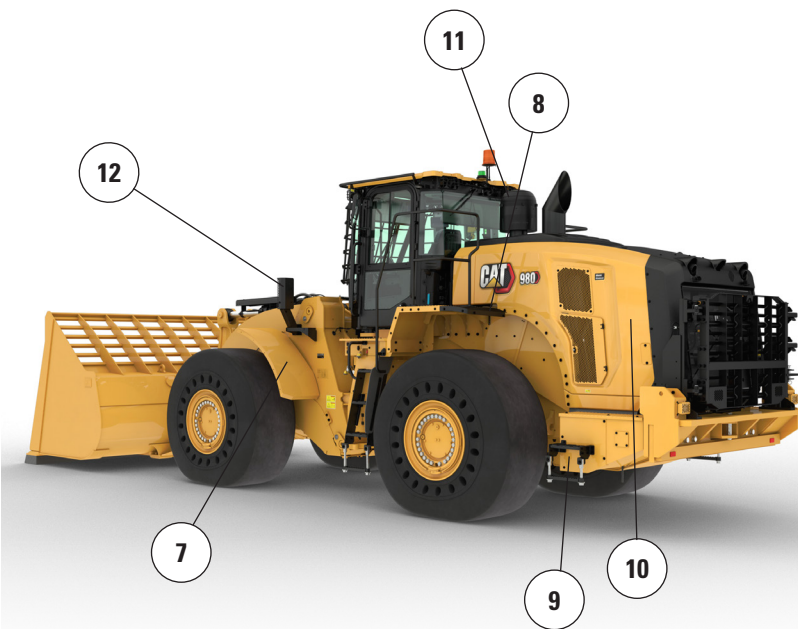
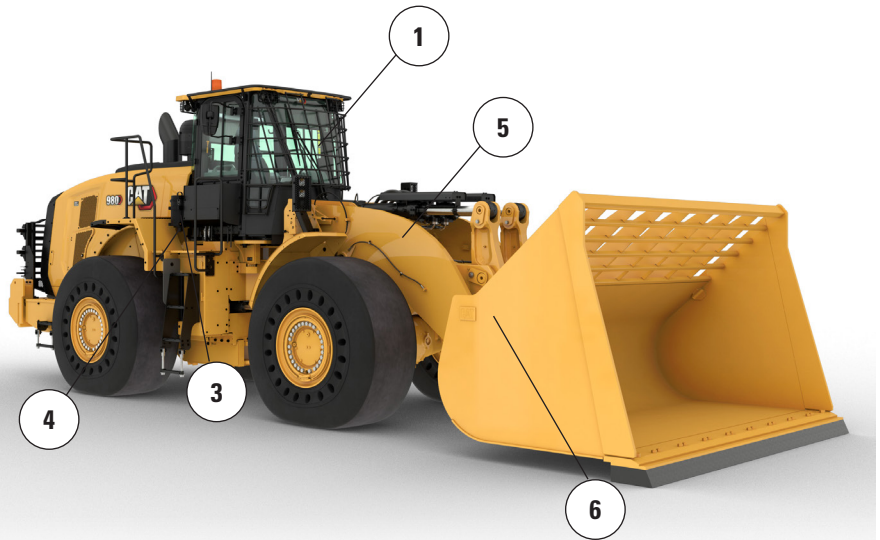

7. Narrow front steel fenders help to keep the windshield clean and are set inboard of the outer edge of the tire for added protection
8. Optional rear guard protects the rear grill and cooling package from impact
9. Heavy-duty steel cable lower steps stand up to the harshest conditions
10. Optional variable pitch fan and high debris cooling cores help to keep the cooling package clean
11. Optional turbine engine air precleaner with a trash screen option help to extend engine air filter life
12. Front lights are guarded and positioned close to the frame for added protection

980 Waste & Scrap Handler Specifications

Tire Options

Tire Brand	Brawler	Michelin	Michelin	Michelin
Tire Size	29.5-25	29.5-25	29.5-25	29.5-25
Tread Type	Solid	L-4	L-5	L-5
Tread Pattern	Traction/Smooth	XLDD1	XLDD2	XMINED2
Width over Tires – Maximum (empty)*	3216 mm 10'7"	3258 mm 10'9"	3256 mm 10'9"	3275 mm 10'9"
Width over Tires – Maximum (loaded)*	3230 mm 10'8"	3302 mm 10'10"	3296 mm 10'10"	3294 mm 10'10"
Change in Vertical Dimensions (average of front and rear)		-16 mm -0.6"	-15 mm -0.6"	-4 mm -0.2"
Change in Horizontal Reach		-31 mm -1.2"	-28 mm -1.1"	-28 mm -1.1"
Change in Clearance Circle to Outside of Tires		72 mm 2.8"	67 mm 2.6"	64 mm 2.5"
Change in Clearance Circle to Inside of Tires		-72 mm -2.8"	-67 mm -2.6"	-64 mm -2.5"
Change in Operating Weight (without Ballast)		-5928 kg -13,071 lb	-5564 kg -12,269 lb	-5240 kg -11,554 lb
Change in Static Tipping Load – Straight		-4508 kg -9,941 lb	-4231 kg -9,330 lb	-3985 kg -8,787 lb
Change in Static Tipping Load – Articulated		-3924 kg -8,653 lb	-3683 kg -8,122 lb	-3469 kg -7,649 lb
Rear Axle Oscillation Angle	±8 degrees	±13 degrees	±13 degrees	±13 degrees
Maximum Single-wheel Rise and Fall	340 mm 1'1"	549 mm 1'10"	549 mm 1'10"	549 mm 1'10"

*Width over tire bulge and includes tire growth.

Tire Brand	Bridgestone	Bridgestone	Bridgestone	Bridgestone
Tire Size	29.5R25	29.5R25	29.5R25	29.5R25
Tread Type	L-3	L-4	L-5	L-5
Tread Pattern	VJT	VSNT	VSDT	VSDL
Width over Tires – Maximum (empty)*	3263 mm 10'9"	3240 mm 10'8"	3272 mm 10'9"	3250 mm 10'8"
Width over Tires – Maximum (loaded)*	3289 mm 10'10"	3260 mm 10'9"	3301 mm 10'10"	3275 mm 10'9"
Change in Vertical Dimensions (average of front and rear)	-32 mm -1.3"	-9 mm -0.4"	-5 mm -0.2"	11 mm 0.4"
Change in Horizontal Reach	-10 mm -0.4"	-30 mm -1.2"	-30 mm -1.2"	-40 mm -1.6"
Change in Clearance Circle to Outside of Tires	59 mm 2.3"	30 mm 1.2"	72 mm 2.8"	45 mm 1.8"
Change in Clearance Circle to Inside of Tires	-59 mm -2.3"	-30 mm -1.2"	-72 mm -2.8"	-45 mm -1.8"
Change in Operating Weight (without Ballast)	-6456 kg -14,235 lb	-5772 kg -12,727 lb	-5272 kg -11,625 lb	-5064 kg -11,166 lb
Change in Static Tipping Load – Straight	-4910 kg -10,826 lb	-4390 kg -9,679 lb	-4009 kg -8,841 lb	-3851 kg -8,492 lb
Change in Static Tipping Load – Articulated	-4274 kg -9,424 lb	-3821 kg -8,425 lb	-3490 kg -7,696 lb	-3352 kg -7,392 lb
Rear Axle Oscillation Angle	±13 degrees	±13 degrees	±13 degrees	±13 degrees
Maximum Single-wheel Rise and Fall	549 mm 1'10"	549 mm 1'10"	549 mm 1'10"	549 mm 1'10"

*Width over tire bulge and includes tire growth.

980 Waste & Scrap Handler Specifications

Tire Options

Tire Brand	Maxam	Maxam	Maxam	Michelin
Tire Size	29.5-25	29.5-25	29.5-25	29.5-25
Tread Type	L-3	L-4	L-5	L-3
Tread Pattern	MS302	MS405DX	MS503	XHA2
Width over Tires – Maximum (empty)*	3270 mm 10'9"	3256 mm 10'9"	3268 mm 10'9"	3270 mm 10'9"
Width over Tires – Maximum (loaded)*	3290 mm 10'10"	3282 mm 10'10"	3304 mm 10'11"	3296 mm 10'10"
Change in Vertical Dimensions (average of front and rear)	-28 mm -1.1"	-42 mm -1.7"	-15 mm -0.6"	-49 mm -1.9"
Change in Horizontal Reach	-25 mm -1"	-12 mm -0.5"	-33 mm -1.3"	-8 mm -0.3"
Change in Clearance Circle to Outside of Tires	60 mm 2.4"	52 mm 2.1"	75 mm 2.9"	66 mm 2.6"
Change in Clearance Circle to Inside of Tires	-60 mm -2.4"	-52 mm -2.1"	-75 mm -2.9"	-66 mm -2.6"
Change in Operating Weight (without Ballast)	-6300 kg -13,892 lb	-6160 kg -13,583 lb	-5520 kg -12,172 lb	-6472 kg -14,271 lb
Change in Static Tipping Load – Straight	-4791 kg -10,564 lb	-4685 kg -10,330 lb	-4198 kg -9,257 lb	-4922 kg -10,853 lb
Change in Static Tipping Load – Articulated	-4171 kg -9,196 lb	-4078 kg -8,992 lb	-3654 kg -8,058 lb	-4284 kg -9,447 lb
Rear Axle Oscillation Angle	±13 degrees	±13 degrees	±13 degrees	±13 degrees
Maximum Single-wheel Rise and Fall	549 mm 1'10"	549 mm 1'10"	549 mm 1'10"	549 mm 1'10"

*Width over tire bulge and includes tire growth.

Tire Brand	Michelin	Bridgestone	Bridgestone	Maxam
Tire Size	875/65R29	875/65R29	875/65R29	875/65R29
Tread Type	L-3	L-3	L-4	L-4
Tread Pattern	XHA2	VTS	VLTS	MS405DX
Width over Tires – Maximum (empty)*	3373 mm 11'1"	3341 mm 11'0"	3344 mm 11'0"	3357 mm 11'1"
Width over Tires – Maximum (loaded)*	3384 mm 11'2"	3359 mm 11'1"	3366 mm 11'1"	3382 mm 11'2"
Change in Vertical Dimensions (average of front and rear)	-34 mm -1.4"	-28 mm -1.1"	-26 mm -1"	-43 mm -1.7"
Change in Horizontal Reach	-13 mm -0.5"	-10 mm -0.4"	-12 mm -0.5"	-12 mm 152 mm
Change in Clearance Circle to Outside of Tires	155 mm 6.1"	129 mm 5.1"	136 mm 5.4"	6" -152 mm
Change in Clearance Circle to Inside of Tires	-155 mm -6.1"	-129 mm -5.1"	-136 mm -5.4"	-6" -5464 kg
Change in Operating Weight (without Ballast)	-5812 kg -12,815 lb	-5532 kg -12,198 lb	-5456 kg -12,030 lb	-12,048 lb -4155 kg
Change in Static Tipping Load – Straight	-4420 kg -9,746 lb	-4207 kg -9,277 lb	-4149 kg -9,149 lb	-9,163 lb -3617 kg
Change in Static Tipping Load – Articulated	-3848 kg -8,484 lb	-3662 kg -8,075 lb	-3612 kg -7,964 lb	-7,976 lb 8,425 lb
Rear Axle Oscillation Angle	±8 degrees	±8 degrees	±8 degrees	±8 degrees
Maximum Single-wheel Rise and Fall	340 mm 1'1"	340 mm 1'1"	340 mm 1'1"	340 mm 1'1"

*Width over tire bulge and includes tire growth.

980 Waste & Scrap Handler Specifications

Operating Specifications – Buckets

Linkage		Standard Linkage	
Bucket Type		General Purpose – Pin-On	General Purpose – Hook-On – Fusion
Edge Type		Bolt-On Cutting Edges	Bolt-On Cutting Edges
Capacity – Rated	m ³	5.40	5.40
	yd ³	7.00	7.00
Capacity – Rated at 110% Fill Factor	m ³	5.90	5.90
	yd ³	7.75	7.75
Width	mm	3447	3447
	ft/in	11'3"	11'3"
16 † Dump Clearance at Maximum Lift and 45° Discharge	mm	3292	3187
	ft/in	10'9"	10'5"
17 † Reach at Maximum Lift and 45° Discharge	mm	1510	1618
	ft/in	4'11"	5'3"
Reach at Level Lift Arm and Bucket Level	mm	2994	3146
	ft/in	9'9"	10'3"
A † Digging Depth	mm	84	89
	in	3.3"	3.5"
12 † Overall Length	mm	9613	9769
	ft/in	31'7"	32'1"
B † Overall Height with Bucket at Maximum Lift	mm	6432	6536
	ft/in	21'2"	21'6"
Loader Clearance Circle Radius with Bucket at Carry Position	mm	7614	7697
	ft/in	25'0"	25'4"
Static Tipping Load, Straight (With tire deflection)	kg	N/A	N/A
	lb	N/A	N/A
Static Tipping Load, Straight (No tire deflection)	kg	29 260	27 802
	lb	64,490	61,276
Static Tipping Load, Articulated (With tire deflection)	kg	N/A	N/A
	lb	N/A	N/A
Static Tipping Load, Articulated (No tire deflection)	kg	25 415	24 063
	lb	56,015	53,036
Breakout Force (§)	kN	226	204
	lbf	50,946	45,849
Operating Weight*	kg	36 885	37 567
	lb	81,294	82,796

* Static tipping loads and operating weights shown are based on a machine configuration with Brawler 29.5X25 Smooth solid tires, full fluids, operator, cab precleaner, fabricated counterweight with rear guard, flat window glass with front guard, industrial package, ride control, standard starting, narrow fenders, turbine engine precleaner, Product Link, front limited slip differentials, power train guard, standard steering, industrial sound suppression and variable pitch fan.

† Illustration shown with Dimension charts.

(§) Measured 100 mm (4") behind tip of cutting edge with bucket hinge pin as pivot point in accordance with ISO 14397-2:2007.

(With tire deflection) Full compliance to ISO 14397-1:2007 Sections 1 thru 6, which requires 2% verification between calculations and testing.

(No tire deflection) Compliance to ISO 14397-1:2007 Sections 1 thru 5.

Other buckets are available and offerings vary by region. Consult your local Cat dealer for further details.

980 Waste & Scrap Handler Specifications

Operating Specifications – Buckets

Linkage		Standard Linkage	
Bucket Type		General Purpose – Pin-On	General Purpose – Hook-On – Fusion
Edge Type		Bolt-On Cutting Edges	Bolt-On Cutting Edges
Capacity – Rated	m ³	5.70	5.70
	yd ³	7.50	7.50
Capacity – Rated at 110% Fill Factor	m ³	6.30	6.30
	yd ³	8.25	8.25
Width	mm	3481	3481
	ft/in	11'5"	11'5"
16 † Dump Clearance at Maximum Lift and 45° Discharge	mm	3233	3123
	ft/in	10'7"	10'2"
17 † Reach at Maximum Lift and 45° Discharge	mm	1567	1668
	ft/in	5'1"	5'5"
Reach at Level Lift Arm and Bucket Level	mm	3079	3228
	ft/in	10'1"	10'7"
A † Digging Depth	mm	72	89
	in	2.8"	3.5"
12 † Overall Length	mm	9689	9851
	ft/in	31'10"	32'4"
B † Overall Height with Bucket at Maximum Lift	mm	6505	6604
	ft/in	21'5"	21'8"
Loader Clearance Circle Radius with Bucket at Carry Position	mm	7648	7739
	ft/in	25'2"	25'5"
Static Tipping Load, Straight (With tire deflection)	kg	N/A	N/A
	lb	N/A	N/A
Static Tipping Load, Straight (No tire deflection)	kg	28 232	27 540
	lb	62,225	60,698
Static Tipping Load, Articulated (With tire deflection)	kg	N/A	N/A
	lb	N/A	N/A
Static Tipping Load, Articulated (No tire deflection)	kg	24 387	23 817
	lb	53,749	52,494
Breakout Force (§)	kN	210	193
	lbf	47,341	43,442
Operating Weight*	kg	37 820	37 689
	lb	83,354	83,067

*Static tipping loads and operating weights shown are based on a machine configuration with Brawler 29.5X25 Smooth solid tires, full fluids, operator, cab precleaner, fabricated counterweight with rear guard, flat window glass with front guard, industrial package, ride control, standard starting, narrow fenders, turbine engine precleaner, Product Link, front limited slip differentials, power train guard, standard steering, industrial sound suppression and variable pitch fan.

† Illustration shown with Dimension charts.

(§) Measured 100 mm (4") behind tip of cutting edge with bucket hinge pin as pivot point in accordance with ISO 14397-2:2007.

(With tire deflection) Full compliance to ISO 14397-1:2007 Sections 1 thru 6, which requires 2% verification between calculations and testing.

(No tire deflection) Compliance to ISO 14397-1:2007 Sections 1 thru 5.

Other buckets are available and offerings vary by region. Consult your local Cat dealer for further details.

980 Waste & Scrap Handler Specifications

Operating Specifications – Buckets

Linkage		Standard Linkage	
Bucket Type		General Purpose – Pin-On	
Edge Type		Bolt-On Cutting Edges	Bolt-On Cutting Edges
Capacity – Rated	m ³	6.00	6.40
	yd ³	7.75	8.25
Capacity – Rated at 110% Fill Factor	m ³	6.60	7.00
	yd ³	8.75	9.25
Width	mm	3481	3413
	ft/in	11'5"	11'2"
16 † Dump Clearance at Maximum Lift and 45° Discharge	mm	3205	3150
	ft/in	10'6"	10'4"
17 † Reach at Maximum Lift and 45° Discharge	mm	1580	1633
	ft/in	5'2"	5'4"
Reach at Level Lift Arm and Bucket Level	mm	3107	3185
	ft/in	10'2"	10'5"
A † Digging Depth	mm	84	84
	in	3.3"	3.3"
12 † Overall Length	mm	9726	9804
	ft/in	31'11"	32'2"
B † Overall Height with Bucket at Maximum Lift	mm	6528	6608
	ft/in	21'5"	21'9"
Loader Clearance Circle Radius with Bucket at Carry Position	mm	7660	7651
	ft/in	25'2"	25'2"
Static Tipping Load, Straight (With tire deflection)	kg	N/A	N/A
	lb	N/A	N/A
Static Tipping Load, Straight (No tire deflection)	kg	28 965	28 752
	lb	63,840	63,370
Static Tipping Load, Articulated (With tire deflection)	kg	N/A	N/A
	lb	N/A	N/A
Static Tipping Load, Articulated (No tire deflection)	kg	25 132	24 933
	lb	55,392	54,954
Breakout Force (§)	kN	209	199
	lbf	47,095	44,724
Operating Weight*	kg	37 060	37 145
	lb	81,679	81,867

* Static tipping loads and operating weights shown are based on a machine configuration with Brawler 29.5X25 Smooth solid tires, full fluids, operator, cab precleaner, fabricated counterweight with rear guard, flat window glass with front guard, industrial package, ride control, standard starting, narrow fenders, turbine engine precleaner, Product Link, front limited slip differentials, power train guard, standard steering, industrial sound suppression and variable pitch fan.

† Illustration shown with Dimension charts.

(§) Measured 100 mm (4") behind tip of cutting edge with bucket hinge pin as pivot point in accordance with ISO 14397-2:2007.

(With tire deflection) Full compliance to ISO 14397-1:2007 Sections 1 thru 6, which requires 2% verification between calculations and testing.

(No tire deflection) Compliance to ISO 14397-1:2007 Sections 1 thru 5.

Other buckets are available and offerings vary by region. Consult your local Cat dealer for further details.

980 Waste & Scrap Handler Specifications

Operating Specifications – Buckets

Linkage		Standard Linkage	
Bucket Type		Waste, Dozing – Pin-On	Waste, Load and Carry – Pin-On
Edge Type		Bolt-On Cutting Edges	Rubber Edge
Capacity – Rated	m ³	9.90	10.70
	yd ³	13.00	14.00
Capacity – Rated at 110% Fill Factor	m ³	10.90	11.80
	yd ³	14.25	15.50
Width	mm	3882	3882
	ft/in	12'8"	12'8"
16 † Dump Clearance at Maximum Lift and 45° Discharge	mm	3072	2760
	ft/in	10'0"	9'0"
17 † Reach at Maximum Lift and 45° Discharge	mm	1490	1650
	ft/in	4'10"	5'4"
Reach at Level Lift Arm and Bucket Level	mm	3153	3487
	ft/in	10'4"	11'5"
A † Digging Depth	mm	110	70
	in	4.3"	2.7"
12 † Overall Length	mm	9793	10 207
	ft/in	32'2"	33'6"
B † Overall Height with Bucket at Maximum Lift	mm	7135	6962
	ft/in	23'5"	22'11"
Loader Clearance Circle Radius with Bucket at Carry Position	mm	7865	7996
	ft/in	25'10"	26'3"
Static Tipping Load, Straight (With tire deflection)	kg	N/A	N/A
	lb	N/A	N/A
Static Tipping Load, Straight (No tire deflection)	kg	30 342	27 596
	lb	66,875	60,822
Static Tipping Load, Articulated (With tire deflection)	kg	N/A	N/A
	lb	N/A	N/A
Static Tipping Load, Articulated (No tire deflection)	kg	26 227	23 791
	lb	57,804	52,437
Breakout Force (§)	kN	204	170
	lbf	46,014	38,403
Operating Weight*	kg	38 062	38 214
	lb	83,889	84,223

* Static tipping loads and operating weights shown are based on a machine configuration with Brawler 29.5X25 Smooth solid tires, full fluids, operator, cab precleaner, fabricated counterweight with rear guard, flat window glass with front guard, industrial package, ride control, standard starting, narrow fenders, turbine engine precleaner, Product Link, front limited slip differentials, power train guard, standard steering, industrial sound suppression and variable pitch fan.

† Illustration shown with Dimension charts.

(§) Measured 100 mm (4") behind tip of cutting edge with bucket hinge pin as pivot point in accordance with ISO 14397-2:2007.

(With tire deflection) Full compliance to ISO 14397-1:2007 Sections 1 thru 6, which requires 2% verification between calculations and testing.

(No tire deflection) Compliance to ISO 14397-1:2007 Sections 1 thru 5.

Other buckets are available and offerings vary by region. Consult your local Cat dealer for further details.

980 Waste & Scrap Handler Specifications

Operating Specifications – Buckets

Linkage		High Lift Linkage	
Bucket Type		General Purpose – Pin-On	General Purpose – Hook-On – Fusion
Edge Type		Bolt-On Cutting Edges	Bolt-On Cutting Edges
Capacity – Rated	m ³	5.40	5.40
	yd ³	7.00	7.00
Capacity – Rated at 110% Fill Factor	m ³	5.90	5.90
	yd ³	7.75	7.75
Width	mm	3447	3447
	ft/in	11'3"	11'3"
16 † Dump Clearance at Maximum Lift and 45° Discharge	mm	3513	3408
	ft/in	11'6"	11'2"
17 † Reach at Maximum Lift and 45° Discharge	mm	1513	1621
	ft/in	4'11"	5'3"
Reach at Level Lift Arm and Bucket Level	mm	3154	3306
	ft/in	10'4"	10'10"
A † Digging Depth	mm	82	87
	in	3.2"	3.4"
12 † Overall Length	mm	9815	9971
	ft/in	32'3"	32'9"
B † Overall Height with Bucket at Maximum Lift	mm	6653	6757
	ft/in	21'10"	22'2"
Loader Clearance Circle Radius with Bucket at Carry Position	mm	8115	8202
	ft/in	26'8"	26'11"
Static Tipping Load, Straight (With tire deflection)	kg	N/A	N/A
	lb	N/A	N/A
Static Tipping Load, Straight (No tire deflection)	kg	26 713	25 350
	lb	58,877	55,872
Static Tipping Load, Articulated (With tire deflection)	kg	N/A	N/A
	lb	N/A	N/A
Static Tipping Load, Articulated (No tire deflection)	kg	23 636	22 355
	lb	52,093	49,271
Breakout Force (§)	kN	230	207
	lbf	51,711	46,549
Operating Weight*	kg	37 019	37 700
	lb	81,589	83,091

* Static tipping loads and operating weights shown are based on a machine configuration with Brawler 29.5X25 Smooth solid tires, full fluids, operator, cab precleaner, fabricated counterweight with rear guard, flat window glass with front guard, industrial package, ride control, standard starting, narrow fenders, turbine engine precleaner, Product Link, front limited slip differentials, power train guard, standard steering, industrial sound suppression and variable pitch fan.

† Illustration shown with Dimension charts.

(§) Measured 100 mm (4") behind tip of cutting edge with bucket hinge pin as pivot point in accordance with ISO 14397-2:2007.

(With tire deflection) Full compliance to ISO 14397-1:2007 Sections 1 thru 6, which requires 2% verification between calculations and testing.

(No tire deflection) Compliance to ISO 14397-1:2007 Sections 1 thru 5.

Other buckets are available and offerings vary by region. Consult your local Cat dealer for further details.

980 Waste & Scrap Handler Specifications

Operating Specifications – Buckets

Linkage		High Lift Linkage	
Bucket Type		General Purpose – Pin-On	General Purpose – Hook-On – Fusion
Edge Type		Bolt-On Cutting Edges	Bolt-On Cutting Edges
Capacity – Rated	m ³	5.70	5.70
	yd ³	7.50	7.50
Capacity – Rated at 110% Fill Factor	m ³	6.30	6.30
	yd ³	8.25	8.25
Width	mm	3481	3481
	ft/in	11'5"	11'5"
16 † Dump Clearance at Maximum Lift and 45° Discharge	mm	3454	3343
	ft/in	11'3"	10'11"
17 † Reach at Maximum Lift and 45° Discharge	mm	1570	1671
	ft/in	5'1"	5'5"
Reach at Level Lift Arm and Bucket Level	mm	3239	3388
	ft/in	10'7"	11'1"
A † Digging Depth	mm	70	87
	in	2.7"	3.4"
12 † Overall Length	mm	9891	10 053
	ft/in	32'6"	33'0"
B † Overall Height with Bucket at Maximum Lift	mm	6725	6824
	ft/in	22'1"	22'5"
Loader Clearance Circle Radius with Bucket at Carry Position	mm	8149	8243
	ft/in	26'9"	27'1"
Static Tipping Load, Straight (With tire deflection)	kg	N/A	N/A
	lb	N/A	N/A
Static Tipping Load, Straight (No tire deflection)	kg	25 683	25 097
	lb	56,606	55,315
Static Tipping Load, Articulated (With tire deflection)	kg	N/A	N/A
	lb	N/A	N/A
Static Tipping Load, Articulated (No tire deflection)	kg	22 606	22 115
	lb	49,825	48,742
Breakout Force (§)	kN	213	196
	lbf	48,058	44,110
Operating Weight*	kg	37 953	37 823
	lb	83,648	83,361

* Static tipping loads and operating weights shown are based on a machine configuration with Brawler 29.5X25 Smooth solid tires, full fluids, operator, cab precleaner, fabricated counterweight with rear guard, flat window glass with front guard, industrial package, ride control, standard starting, narrow fenders, turbine engine precleaner, Product Link, front limited slip differentials, power train guard, standard steering, industrial sound suppression and variable pitch fan.

† Illustration shown with Dimension charts.

(§) Measured 100 mm (4") behind tip of cutting edge with bucket hinge pin as pivot point in accordance with ISO 14397-2:2007.

(With tire deflection) Full compliance to ISO 14397-1:2007 Sections 1 thru 6, which requires 2% verification between calculations and testing.

(No tire deflection) Compliance to ISO 14397-1:2007 Sections 1 thru 5.

Other buckets are available and offerings vary by region. Consult your local Cat dealer for further details.

980 Waste & Scrap Handler Specifications

Operating Specifications – Buckets

Linkage		High Lift Linkage	
Bucket Type		General Purpose – Pin-On	
Edge Type		Bolt-On Cutting Edges	Bolt-On Cutting Edges
Capacity – Rated	m ³	6.00	6.40
	yd ³	7.75	8.25
Capacity – Rated at 110% Fill Factor	m ³	6.60	7.00
	yd ³	8.75	9.25
Width	mm	3481	3413
	ft/in	11'5"	11'2"
16 † Dump Clearance at Maximum Lift and 45° Discharge	mm	3426	3370
	ft/in	11'2"	11'0"
17 † Reach at Maximum Lift and 45° Discharge	mm	1583	1636
	ft/in	5'2"	5'4"
Reach at Level Lift Arm and Bucket Level	mm	3267	3345
	ft/in	10'8"	10'11"
A † Digging Depth	mm	82	82
	in	3.2"	3.2"
12 † Overall Length	mm	9928	10 006
	ft/in	32'7"	32'10"
B † Overall Height with Bucket at Maximum Lift	mm	6749	6829
	ft/in	22'2"	22'5"
Loader Clearance Circle Radius with Bucket at Carry Position	mm	8161	8152
	ft/in	26'10"	26'9"
Static Tipping Load, Straight (With tire deflection)	kg	N/A	N/A
	lb	N/A	N/A
Static Tipping Load, Straight (No tire deflection)	kg	26 420	26 213
	lb	58,231	57,775
Static Tipping Load, Articulated (With tire deflection)	kg	N/A	N/A
	lb	N/A	N/A
Static Tipping Load, Articulated (No tire deflection)	kg	23 353	23 158
	lb	51,471	51,041
Breakout Force (§)	kN	212	202
	lbf	47,808	45,405
Operating Weight*	kg	37 193	37 278
	lb	81,974	82,161

* Static tipping loads and operating weights shown are based on a machine configuration with Brawler 29.5X25 Smooth solid tires, full fluids, operator, cab precleaner, fabricated counterweight with rear guard, flat window glass with front guard, industrial package, ride control, standard starting, narrow fenders, turbine engine precleaner, Product Link, front limited slip differentials, power train guard, standard steering, industrial sound suppression and variable pitch fan.

† Illustration shown with Dimension charts.

(§) Measured 100 mm (4") behind tip of cutting edge with bucket hinge pin as pivot point in accordance with ISO 14397-2:2007.

(With tire deflection) Full compliance to ISO 14397-1:2007 Sections 1 thru 6, which requires 2% verification between calculations and testing.

(No tire deflection) Compliance to ISO 14397-1:2007 Sections 1 thru 5.

Other buckets are available and offerings vary by region. Consult your local Cat dealer for further details.

980 Waste & Scrap Handler Specifications

Operating Specifications – Buckets

Linkage		High Lift Linkage	
Bucket Type		Waste, Dozing – Pin-On	Waste, Load and Carry – Pin-On
Edge Type		Bolt-On Cutting Edges	Rubber Edge
Capacity – Rated	m ³	9.90	10.70
	yd ³	13.00	14.00
Capacity – Rated at 110% Fill Factor	m ³	10.90	11.80
	yd ³	14.25	15.50
Width	mm	3882	3882
	ft/in	12'8"	12'8"
16 † Dump Clearance at Maximum Lift and 45° Discharge	mm	3292	2980
	ft/in	10'9"	9'9"
17 † Reach at Maximum Lift and 45° Discharge	mm	1493	1653
	ft/in	4'10"	5'5"
Reach at Level Lift Arm and Bucket Level	mm	3313	3647
	ft/in	10'10"	11'11"
A † Digging Depth	mm	108	68
	in	4.2"	2.6"
12 † Overall Length	mm	9993	10 402
	ft/in	32'10"	34'2"
B † Overall Height with Bucket at Maximum Lift	mm	7355	7183
	ft/in	24'2"	23'7"
Loader Clearance Circle Radius with Bucket at Carry Position	mm	8366	8494
	ft/in	27'6"	27'11"
Static Tipping Load, Straight (With tire deflection)	kg	N/A	N/A
	lb	N/A	N/A
Static Tipping Load, Straight (No tire deflection)	kg	27 373	25 011
	lb	60,331	55,124
Static Tipping Load, Articulated (With tire deflection)	kg	N/A	N/A
	lb	N/A	N/A
Static Tipping Load, Articulated (No tire deflection)	kg	24 107	21 973
	lb	53,132	48,430
Breakout Force (§)	kN	207	174
	lbf	46,725	39,103
Operating Weight*	kg	38 196	38 347
	lb	84,183	84,517

* Static tipping loads and operating weights shown are based on a machine configuration with Brawler 29.5X25 Smooth solid tires, full fluids, operator, cab precleaner, fabricated counterweight with rear guard, flat window glass with front guard, industrial package, ride control, standard starting, narrow fenders, turbine engine precleaner, Product Link, front limited slip differentials, power train guard, standard steering, industrial sound suppression and variable pitch fan.

† Illustration shown with Dimension charts.

(§) Measured 100 mm (4") behind tip of cutting edge with bucket hinge pin as pivot point in accordance with ISO 14397-2:2007.

(With tire deflection) Full compliance to ISO 14397-1:2007 Sections 1 thru 6, which requires 2% verification between calculations and testing.

(No tire deflection) Compliance to ISO 14397-1:2007 Sections 1 thru 5.

Other buckets are available and offerings vary by region. Consult your local Cat dealer for further details.

980 Waste & Scrap Handler Specifications

Fork Specifications

Fork Specifications

1	Tine Length	mm	2438
		in	96.0
2	Load Center	mm	1219
		in	48.0
	Static Tipping Load - Straight (Forks Level)	kg	16418
		lbs	36184
	Static Tipping Load - Articulated (Forks Level)	kg	14249
		lbs	31405
	Rated Load (SAE J1197 - 50% FTSTL)	kg	6761
		lbs	14902
	Rated Load (CEN EN 474-3 Rough Terrain - 60% FTSTL)	kg	6761
		lbs	14902
	Rated Load (CEN EN 474-3 Firm and Level Ground - 80% FTSTL)	kg	6761
		lbs	14902
3	Maximum Overall Length	mm	11113
		in	437.5
4	Reach with Forks at Ground Level	mm	1345
		in	53.0
5	*Ground to Bottom of Tine at Minimum Height and Fork Level	mm	-138
		in	-5.5
6	Reach with Arms Horizontal and Forks Level	mm	1870
		in	73.6
7	Reach with Fork at Maximum Height	mm	943
		in	37.1
8	Ground to Top of Tine with Arms Horizontal and Fork Level	mm	2174
		in	85.6
9	Ground to Top of Tine at Maximum Height and Fork Level	mm	4442
		in	174.9
10	Overall Height of Fork at Full Lift (top of carriage to ground)	mm	5814
		in	228.9
11	Clearance at Full Lift and Max Dump	mm	1871
		in	73.7
12	Max Discharge Angle from Horizontal	deg	58
13	Overall Carriage Width	mm	2751
		in	108.3
14	Overall Carriage Height	mm	1575
		in	62.0
15	Outside Tine Width (max spread)	mm	2671
		in	105.1
16	Outside Tine Width (min spread)	mm	849
		in	33.4
	Tine Width (single tine)	mm	88.9
		in	3.5
	Tine Thickness	mm	203.2
		in	8.0
	Tine Capacity	kg	11068
		lbs	24393
	Operating Weight	kg	36462
		lbs	80363

*Negative values indicate below grade

980 IW STD Pallet Fork, Pin-On

96" Tine
473-9104

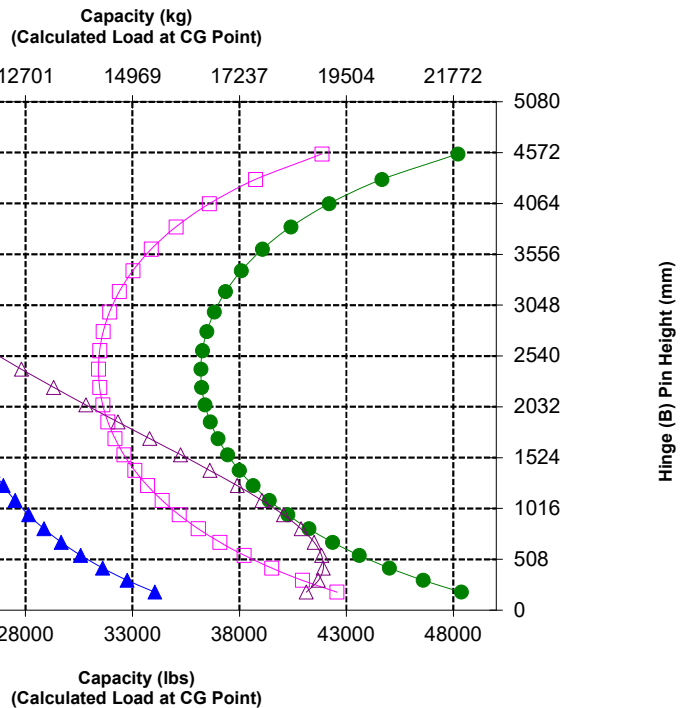
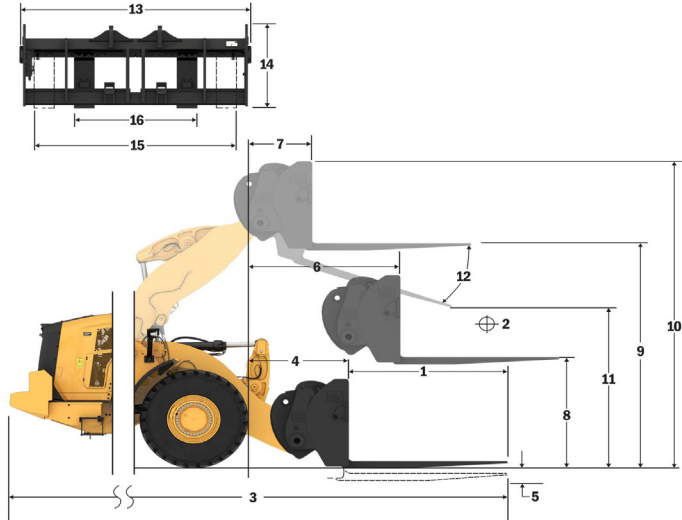

NOTE: Static tipping loads and operating weight are based on the following loader configuration: Brawler Smooth Solid Tires, Air Conditioning, Ride Control, Powertrain Guard, Full Fluids, Fuel Tank, Coolant, Lubricants, and Operator.

Specifications and ratings conform to the following standards: SAE* J1197, ISO 14397-1, CEN** EN 474-3.

The rated operating load for a loader equipped with a pallet fork is determined by:
SAE J1197: 50% of full turn static tipping load or hydraulic limit.
CEN EN 474-3: 60% of full turn static tipping load on rough terrain or hydraulic limit.
CEN EN 474-3: 80% of full turn static tipping load on firm and level ground or hydraulic limit.

*SAE - Society of Automotive Engineers
**CEN - European Committee for Standardization



WARNING: Do not exceed tine load capacity. Individual tine capacity is stamped on the side of each tine.

980 Waste & Scrap Handler Specifications

Fork Specifications

Fork Specifications

1	Tine Length	mm	2438
		in	96.0
2	Load Center	mm	1219
		in	48.0
	Static Tipping Load - Straight (Forks Level)	kg	15574
		lbs	34326
	Static Tipping Load - Articulated (Forks Level)	kg	13783
		lbs	30378
	Rated Load (SAE J1197 - 50% FTSTL)	kg	6586
		lbs	14515
	Rated Load (CEN EN 474-3 Rough Terrain - 60% FTSTL)	kg	6586
		lbs	14515
	Rated Load (CEN EN 474-3 Firm and Level Ground - 80% FTSTL)	kg	6586
		lbs	14515
3	Maximum Overall Length	mm	11302
		in	444.9
4	Reach with Forks at Ground Level	mm	1534
		in	60.4
5	*Ground to Bottom of Tine at Minimum Height and Fork Level	mm	-137
		in	-5.4
6	Reach with Arms Horizontal and Forks Level	mm	2030
		in	79.9
7	Reach with Fork at Maximum Height	mm	946
		in	37.2
8	Ground to Top of Tine with Arms Horizontal and Fork Level	mm	2174
		in	85.6
9	Ground to Top of Tine at Maximum Height and Fork Level	mm	4663
		in	183.6
10	Overall Height of Fork at Full Lift (top of carriage to ground)	mm	6035
		in	237.6
11	Clearance at Full Lift and Max Dump	mm	2334
		in	91.9
12	Max Discharge Angle from Horizontal	deg	49
13	Overall Carriage Width	mm	2751
		in	108.3
14	Overall Carriage Height	mm	1575
		in	62.0
15	Outside Tine Width (max spread)	mm	2671
		in	105.1
16	Outside Tine Width (min spread)	mm	849
		in	33.4
	Tine Width (single tine)	mm	88.9
		in	3.5
	Tine Thickness	mm	203.2
		in	8.0
	Tine Capacity	kg	11068
		lbs	24393
	Operating Weight	kg	36596
		lbs	80657

*Negative values indicate below grade

980 IW HL Pallet Fork, Pin-On

96" Tine
473-9104

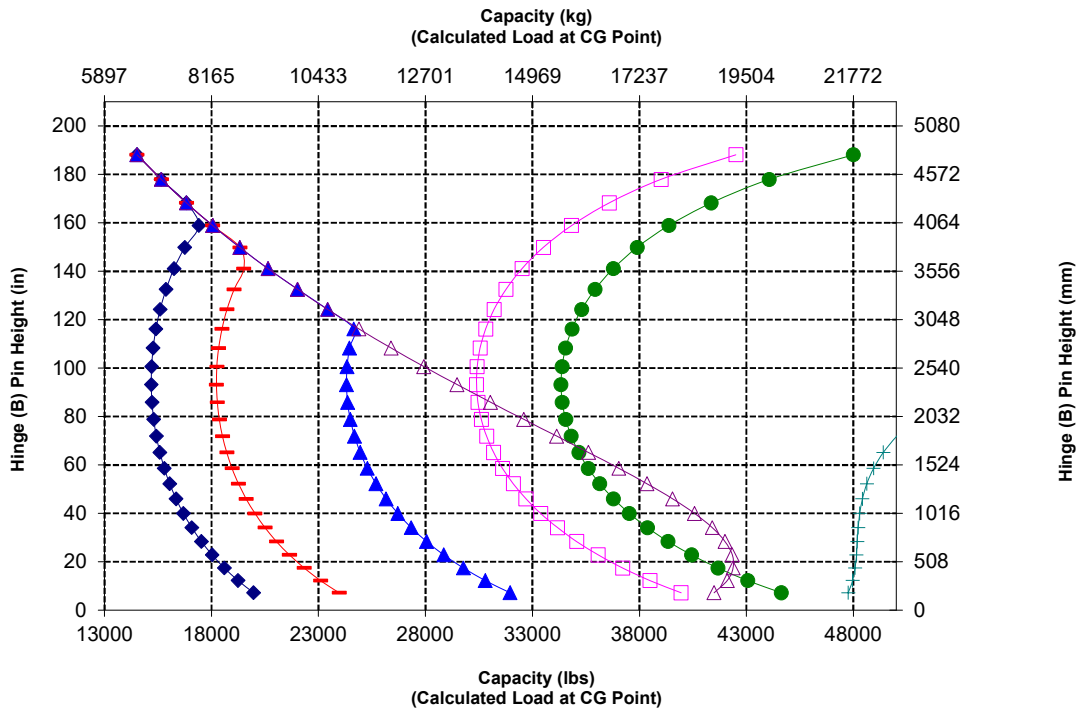
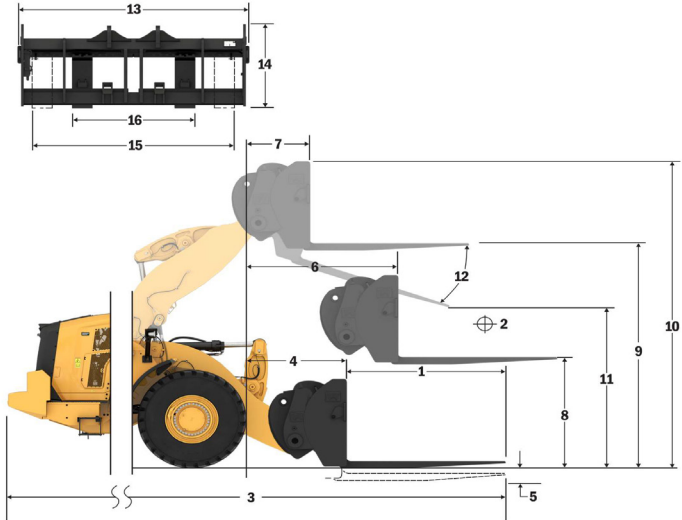

NOTE: Static tipping loads and operating weight are based on the following loader configuration: Brawler Smooth Solid Tires, Air Conditioning, Ride Control, Powertrain Guard, Full Fluids, Fuel Tank, Coolant, Lubricants, and Operator.

Specifications and ratings conform to the following standards: SAE* J1197, ISO 14397-1, CEN** EN 474-3.

The rated operating load for a loader equipped with a pallet fork is determined by:
 SAE J1197: 50% of full turn static tipping load or hydraulic limit.
 CEN EN 474-3: 60% of full turn static tipping load on rough terrain or hydraulic limit.
 CEN EN 474-3: 80% of full turn static tipping load on firm and level ground or hydraulic limit.

*SAE - Society of Automotive Engineers
 **CEN - European Committee for Standardization



WARNING: Do not exceed tine load capacity. Individual tine capacity is stamped on the side of each tine.

980 Waste & Scrap Handler Specifications

Fork Specifications

Fork Specifications

1	Tine Length	mm	1829
		in	72.0
2	Load Center	mm	914
		in	36.0
	Static Tipping Load - Straight (Forks Level)	kg	18021
		lbs	39719
	Static Tipping Load - Articulated (Forks Level)	kg	15675
		lbs	34548
	Rated Load (SAE J1197 - 50% FTSTL)	kg	7838
		lbs	17274
	Rated Load (CEN EN 474-3 Rough Terrain - 60% FTSTL)	kg	8530
		lbs	18799
	Rated Load (CEN EN 474-3 Firm and Level Ground - 80% FTSTL)	kg	8530
		lbs	18799
3	Maximum Overall Length	mm	10507
		in	413.7
4	Reach with Forks at Ground Level	mm	1349
		in	53.1
5	*Ground to Bottom of Tine at Minimum Height and Fork Level	mm	-145
		in	-5.7
6	Reach with Arms Horizontal and Forks Level	mm	1870
		in	73.6
7	Reach with Fork at Maximum Height	mm	943
		in	37.1
8	Ground to Top of Tine with Arms Horizontal and Fork Level	mm	2167
		in	85.3
9	Ground to Top of Tine at Maximum Height and Fork Level	mm	4436
		in	174.6
10	Overall Height of Fork at Full Lift (top of carriage to ground)	mm	5814
		in	228.9
11	Clearance at Full Lift and Max Dump	mm	2386
		in	93.9
12	Max Discharge Angle from Horizontal	deg	58
13	Overall Carriage Width	mm	2751
		in	108.3
14	Overall Carriage Height	mm	1581
		in	62.3
15	Outside Tine Width (max spread)	mm	2671
		in	105.1
16	Outside Tine Width (min spread)	mm	849
		in	33.4
	Tine Width (single tine)	mm	88.9
		in	3.5
	Tine Thickness	mm	203.2
		in	8.0
	Tine Capacity	kg	14742
		lbs	32491
	Operating Weight	kg	36230
		lbs	79852

*Negative values indicate below grade

980 IW STD

Pallet Fork, Pin-On

72" Tine
473-9106

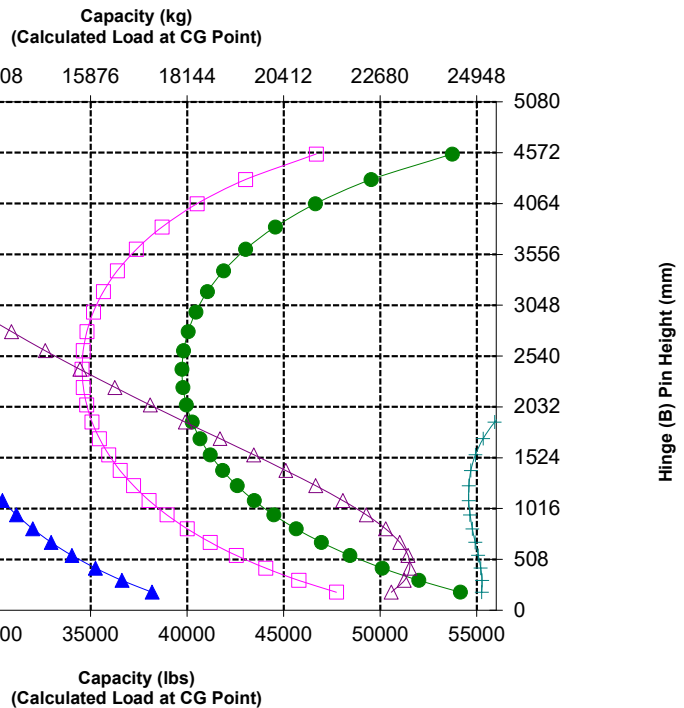
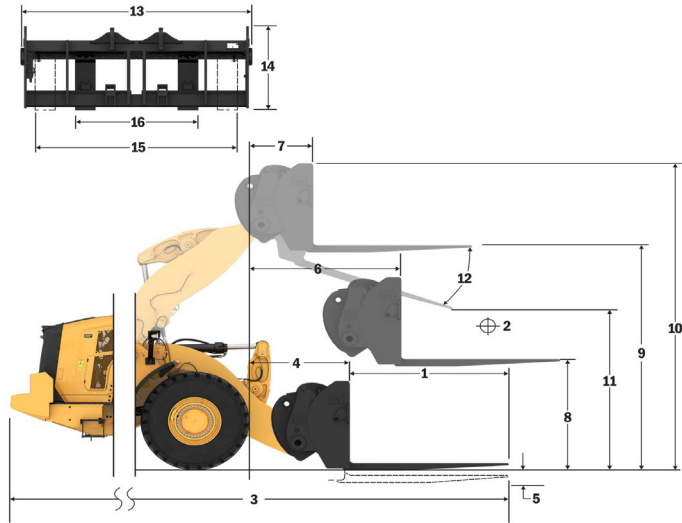

NOTE: Static tipping loads and operating weight are based on the following loader configuration: Brawler Smooth Solid Tires, Air Conditioning, Ride Control, Powertrain Guard, Full Fluids, Fuel Tank, Coolant, Lubricants, and Operator.

Specifications and ratings conform to the following standards: SAE* J1197, ISO 14397-1, CEN** EN 474-3.

The rated operating load for a loader equipped with a pallet fork is determined by:
SAE J1197: 50% of full turn static tipping load or hydraulic limit.
CEN EN 474-3: 60% of full turn static tipping load on rough terrain or hydraulic limit.
CEN EN 474-3: 80% of full turn static tipping load on firm and level ground or hydraulic limit.

*SAE - Society of Automotive Engineers
**CEN - European Committee for Standardization



WARNING: Do not exceed tine load capacity. Individual tine capacity is stamped on the side of each tine.

Fork Specifications

Fork Specifications

1	Tine Length	mm	1829
		in	72.0
2	Load Center	mm	914
		in	36.0
	Static Tipping Load - Straight (Forks Level)	kg	17059
		lbs	37597
	Static Tipping Load - Articulated (Forks Level)	kg	15127
		lbs	33339
	Rated Load (SAE J1197 - 50% FTSTL)	kg	7563
		lbs	16670
	Rated Load (CEN EN 474-3 Rough Terrain - 60% FTSTL)	kg	8317
		lbs	18330
	Rated Load (CEN EN 474-3 Firm and Level Ground - 80% FTSTL)	kg	8317
		lbs	18330
3	Maximum Overall Length	mm	10696
		in	421.1
4	Reach with Forks at Ground Level	mm	1538
		in	60.6
5	*Ground to Bottom of Tine at Minimum Height and Fork Level	mm	-143
		in	-5.6
6	Reach with Arms Horizontal and Forks Level	mm	2030
		in	79.9
7	Reach with Fork at Maximum Height	mm	946
		in	37.2
8	Ground to Top of Tine with Arms Horizontal and Fork Level	mm	2167
		in	85.3
9	Ground to Top of Tine at Maximum Height and Fork Level	mm	4657
		in	183.3
10	Overall Height of Fork at Full Lift (top of carriage to ground)	mm	6035
		in	237.6
11	Clearance at Full Lift and Max Dump	mm	2789
		in	109.8
12	Max Discharge Angle from Horizontal	deg	49
13	Overall Carriage Width	mm	2751
		in	108.3
14	Overall Carriage Height	mm	1581
		in	62.3
15	Outside Tine Width (max spread)	mm	2671
		in	105.1
16	Outside Tine Width (min spread)	mm	849
		in	33.4
	Tine Width (single tine)	mm	88.9
		in	3.5
	Tine Thickness	mm	203.2
		in	8.0
	Tine Capacity	kg	14742
		lbs	32491
	Operating Weight	kg	36364
		lbs	80146

*Negative values indicate below grade

980 IW HL

Pallet Fork, Pin-On

72" Tine
473-9106

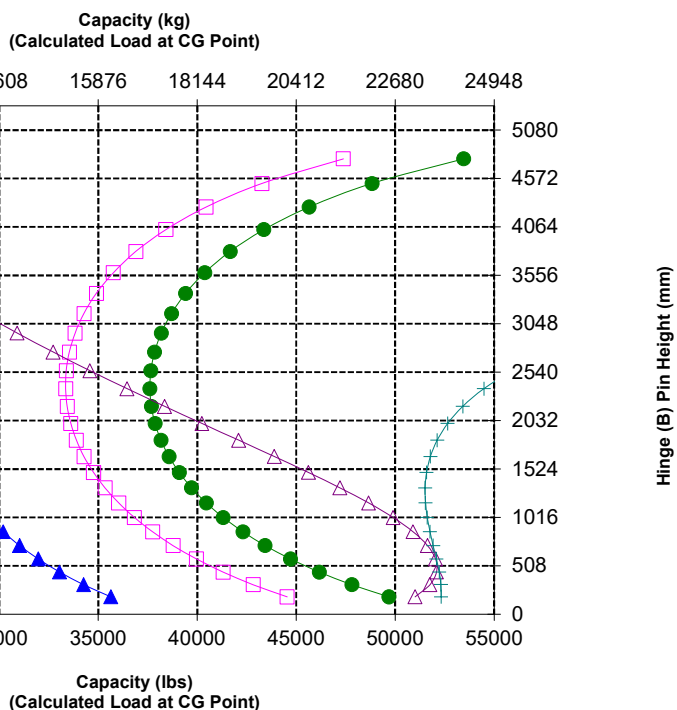
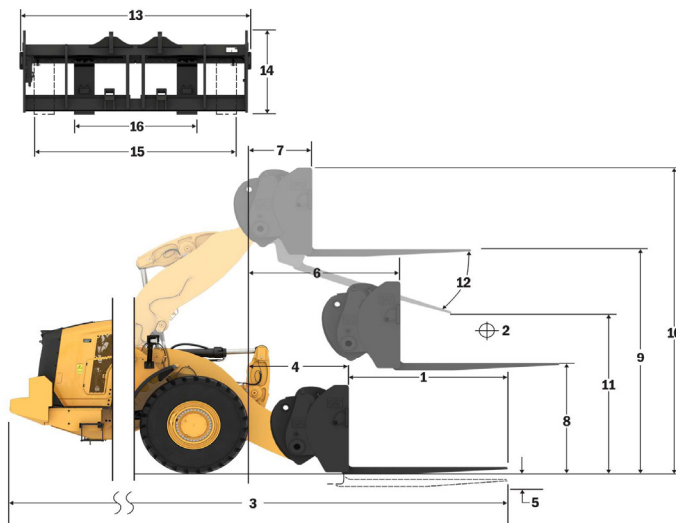

NOTE: Static tipping loads and operating weight are based on the following loader configuration: Brawler Smooth Solid Tires, Air Conditioning, Ride Control, Powertrain Guard, Full Fluids, Fuel Tank, Coolant, Lubricants, and Operator.

Specifications and ratings conform to the following standards: SAE* J1197, ISO 14397-1, CEN** EN 474-3.

The rated operating load for a loader equipped with a pallet fork is determined by:
SAE J1197: 50% of full turn static tipping load or hydraulic limit.
CEN EN 474-3: 60% of full turn static tipping load on rough terrain or hydraulic limit.
CEN EN 474-3: 80% of full turn static tipping load on firm and level ground or hydraulic limit.

*SAE - Society of Automotive Engineers
**CEN - European Committee for Standardization



WARNING: Do not exceed tine load capacity. Individual tine capacity is stamped on the side of each tine.

980 Waste & Scrap Handler Specifications

Fork Specifications

Fork Specifications

1	Tine Length	mm	1830
		in	72.0
2	Load Center	mm	915
		in	36.0
	Static Tipping Load - Straight (Forks Level)	kg	18732
		lbs	41286
	Static Tipping Load - Articulated (Forks Level)	kg	16368
		lbs	36075
	Rated Load (SAE J1197 - 50% FTSTL)	kg	8184
		lbs	18038
	Rated Load (CEN EN 474-3 Rough Terrain - 60% FTSTL)	kg	8327
		lbs	18352
	Rated Load (CEN EN 474-3 Firm and Level Ground - 80% FTSTL)	kg	8327
		lbs	18352
3	Maximum Overall Length	mm	10384
		in	408.8
4	Reach with Forks at Ground Level	mm	1225
		in	48.2
5	*Ground to Bottom of Tine at Minimum Height and Fork Level	mm	-146
		in	-5.8
6	Reach with Arms Horizontal and Forks Level	mm	1839
		in	72.4
7	Reach with Fork at Maximum Height	mm	913
		in	35.9
8	Ground to Top of Tine with Arms Horizontal and Fork Level	mm	2028
		in	79.8
9	Ground to Top of Tine at Maximum Height and Fork Level	mm	4297
		in	169.2
10	Overall Height of Fork at Full Lift (top of carriage to ground)	mm	5072
		in	199.7
11	Clearance at Full Lift and Max Dump	mm	2681
		in	105.5
12	Max Discharge Angle from Horizontal	deg	45
13	Overall Carriage Width	mm	2217
		in	87.3
14	Overall Carriage Height	mm	840
		in	33.1
15	Outside Tine Width (max spread)	mm	2070
		in	81.5
16	Outside Tine Width (min spread)	mm	470
		in	18.5
	Tine Width (single tine)	mm	150.0
		in	5.9
	Tine Thickness	mm	65.0
		in	2.6
	Tine Capacity	kg	5246
		lbs	11562
	Operating Weight	kg	35561
		lbs	78377

*Negative values indicate below grade

980 IW STD

Pallet Fork, FUSION

87" Carriage

72" Tine

530-1861

530-1869

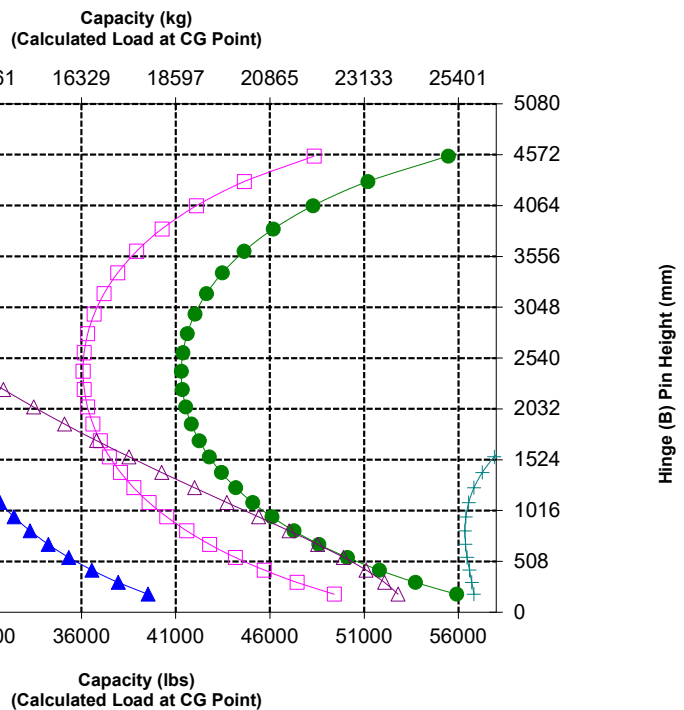
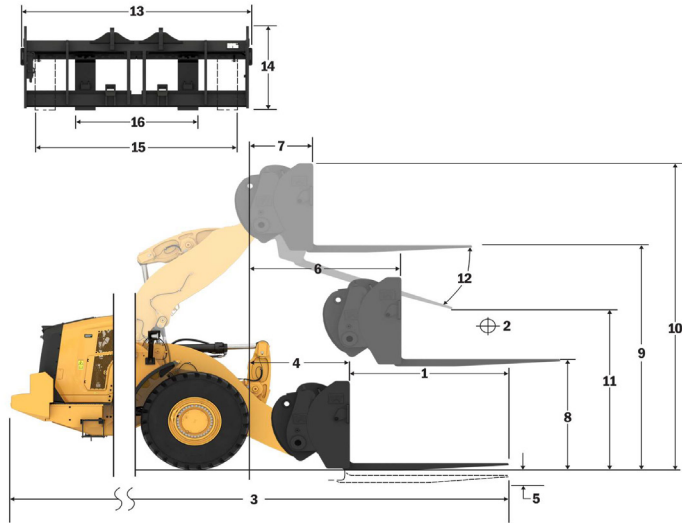

NOTE: Static tipping loads and operating weight are based on the following loader configuration: Brawler Smooth Solid Tires, Air Conditioning, Ride Control, Powertrain Guard, Full Fluids, Fuel Tank, Coolant, Lubricants, and Operator.

Specifications and ratings conform to the following standards: SAE* J1197, ISO 14397-1, CEN** EN 474-3.

The rated operating load for a loader equipped with a pallet fork is determined by:
 SAE J1197: 50% of full turn static tipping load or hydraulic limit.
 CEN EN 474-3: 60% of full turn static tipping load on rough terrain or hydraulic limit.
 CEN EN 474-3: 80% of full turn static tipping load on firm and level ground or hydraulic limit.

*SAE - Society of Automotive Engineers
 **CEN - European Committee for Standardization



WARNING: Do not exceed tine load capacity. Individual tine capacity is stamped on the side of each tine.

980 Waste & Scrap Handler Specifications

Fork Specifications

Fork Specifications

1	Tine Length	mm	1830
		in	72.0
2	Load Center	mm	915
		in	36.0
	Static Tipping Load - Straight (Forks Level)	kg	17694
		lbs	38998
	Static Tipping Load - Articulated (Forks Level)	kg	15754
		lbs	34723
	Rated Load (SAE J1197 - 50% FTSTL)	kg	7877
		lbs	17361
	Rated Load (CEN EN 474-3 Rough Terrain - 60% FTSTL)	kg	7970
		lbs	17566
	Rated Load (CEN EN 474-3 Firm and Level Ground - 80% FTSTL)	kg	7970
		lbs	17566
3	Maximum Overall Length	mm	10593
		in	417.0
4	Reach with Forks at Ground Level	mm	1434
		in	56.4
5	*Ground to Bottom of Tine at Minimum Height and Fork Level	mm	-145
		in	-5.7
6	Reach with Arms Horizontal and Forks Level	mm	2012
		in	79.2
7	Reach with Fork at Maximum Height	mm	928
		in	36.5
8	Ground to Top of Tine with Arms Horizontal and Fork Level	mm	2028
		in	79.8
9	Ground to Top of Tine at Maximum Height and Fork Level	mm	4517
		in	177.8
10	Overall Height of Fork at Full Lift (top of carriage to ground)	mm	5292
		in	208.3
11	Clearance at Full Lift and Max Dump	mm	2759
		in	108.6
12	Max Discharge Angle from Horizontal	deg	51
13	Overall Carriage Width	mm	2217
		in	87.3
14	Overall Carriage Height	mm	840
		in	33.1
15	Outside Tine Width (max spread)	mm	2070
		in	81.5
16	Outside Tine Width (min spread)	mm	470
		in	18.5
	Tine Width (single tine)	mm	150.0
		in	5.9
	Tine Thickness	mm	65.0
		in	2.6
	Tine Capacity	kg	5246
		lbs	11562
	Operating Weight	kg	35699
		lbs	78680

*Negative values indicate below grade

980 IW HL Pallet Fork, FUSION

87" Carriage 72" Tine
530-1861 530-1869

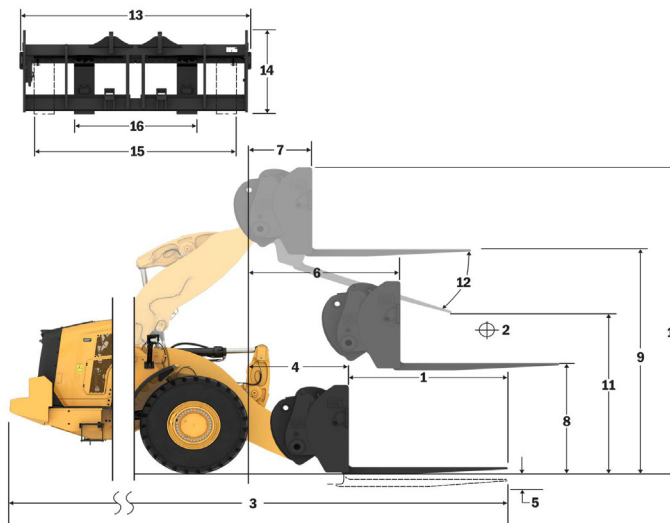

Capacity (kg)
(Calculated Load at CG Point)

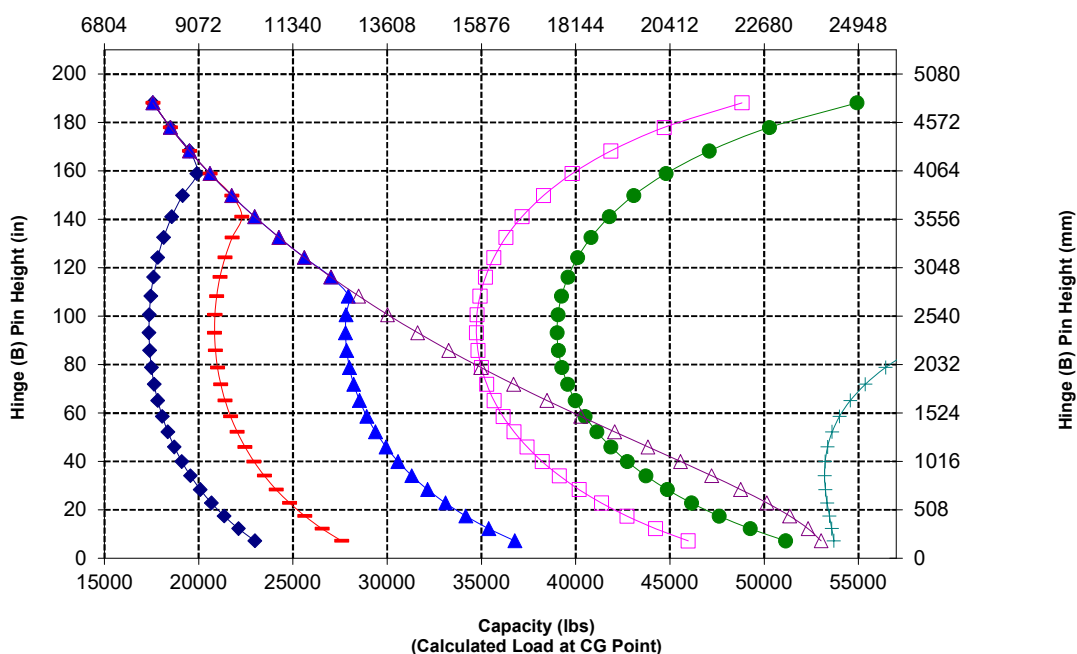

NOTE: Static tipping loads and operating weight are based on the following loader configuration: Brawler Smooth Solid Tires, Air Conditioning, Ride Control, Powertrain Guard, Full Fluids, Fuel Tank, Coolant, Lubricants, and Operator.

Specifications and ratings conform to the following standards: SAE* J1197, ISO 14397-1, CEN** EN 474-3.

The rated operating load for a loader equipped with a pallet fork is determined by:
SAE J1197: 50% of full turn static tipping load or hydraulic limit.
CEN EN 474-3: 60% of full turn static tipping load on rough terrain or hydraulic limit.
CEN EN 474-3: 80% of full turn static tipping load on firm and level ground or hydraulic limit.

*SAE - Society of Automotive Engineers
**CEN - European Committee for Standardization



WARNING: Do not exceed tine load capacity. Individual tine capacity is stamped on the side of each tine.

980 Waste & Scrap Handler Specifications

Fork Specifications

Fork Specifications

1	Tine Length	mm	1829
		in	72.0
2	Load Center	mm	914
		in	36.0
	Static Tipping Load - Straight (Forks Level)	kg	18136
		lbs	39972
	Static Tipping Load - Articulated (Forks Level)	kg	15764
		lbs	34743
	Rated Load (SAE J1197 - 50% FTSTL)	kg	7882
		lbs	17371
	Rated Load (CEN EN 474-3 Rough Terrain - 60% FTSTL)	kg	8905
		lbs	19627
	Rated Load (CEN EN 474-3 Firm and Level Ground - 80% FTSTL)	kg	8905
		lbs	19627
3	Maximum Overall Length	mm	10347
		in	407.4
4	Reach with Forks at Ground Level	mm	1189
		in	46.8
5	*Ground to Bottom of Tine at Minimum Height and Fork Level	mm	-95
		in	-3.7
6	Reach with Arms Horizontal and Forks Level	mm	1826
		in	71.9
7	Reach with Fork at Maximum Height	mm	899
		in	35.4
8	Ground to Top of Tine with Arms Horizontal and Fork Level	mm	2099
		in	82.6
9	Ground to Top of Tine at Maximum Height and Fork Level	mm	4368
		in	172.0
10	Overall Height of Fork at Full Lift (top of carriage to ground)	mm	5412
		in	213.1
11	Clearance at Full Lift and Max Dump	mm	2502
		in	98.5
12	Max Discharge Angle from Horizontal	deg	55
13	Overall Carriage Width	mm	2821
		in	111.1
14	Overall Carriage Height	mm	1129
		in	44.4
15	Outside Tine Width (max spread)	mm	2627
		in	103.4
16	Outside Tine Width (min spread)	mm	747
		in	29.4
	Tine Width (single tine)	mm	250.0
		in	9.8
	Tine Thickness	mm	85.0
		in	3.3
	Tine Capacity	kg	18700
		lbs	41215
	Operating Weight	kg	36438
		lbs	80310

*Negative values indicate below grade

980 IW STD Construction Fork, FUSION

108" Carriage
523-4199

72" Tine
523-4200

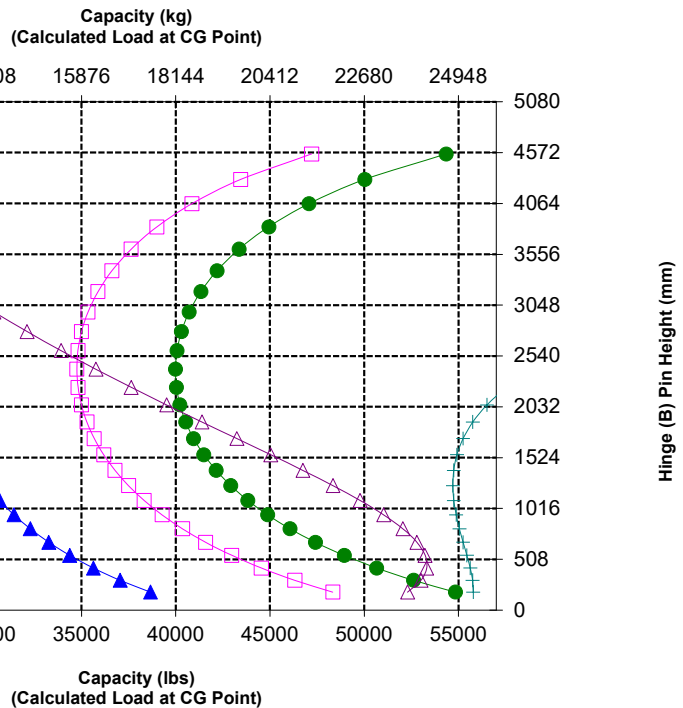
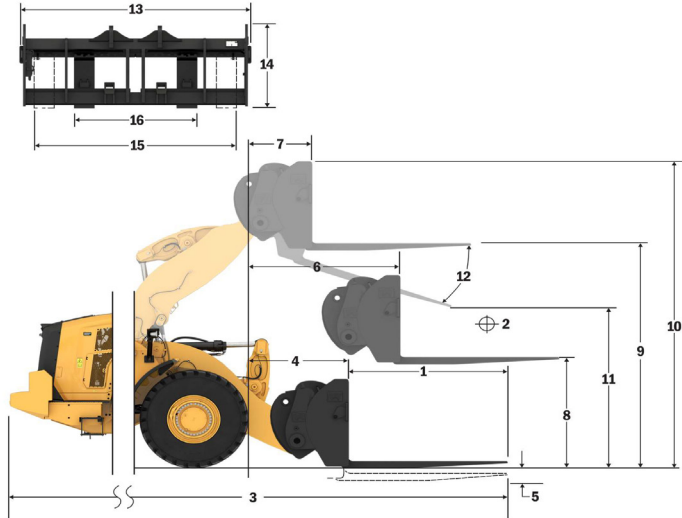

NOTE: Static tipping loads and operating weight are based on the following loader configuration: Brawler Smooth Solid Tires, Air Conditioning, Ride Control, Powertrain Guard, Full Fluids, Fuel Tank, Coolant, Lubricants, and Operator.

Specifications and ratings conform to the following standards: SAE* J1197, ISO 14397-1, CEN** EN 474-3.

The rated operating load for a loader equipped with a pallet fork is determined by:
SAE J1197: 50% of full turn static tipping load or hydraulic limit.
CEN EN 474-3: 60% of full turn static tipping load on rough terrain or hydraulic limit.
CEN EN 474-3: 80% of full turn static tipping load on firm and level ground or hydraulic limit.

*SAE - Society of Automotive Engineers

**CEN - European Committee for Standardization



WARNING: Do not exceed tine load capacity. Individual tine capacity is stamped on the side of each tine.

980 Waste & Scrap Handler Specifications

Fork Specifications

Fork Specifications

1	Tine Length	mm	1829
		in	72.0
2	Load Center	mm	914
		in	36.0
	Static Tipping Load - Straight (Forks Level)	kg	17083
		lbs	37651
	Static Tipping Load - Articulated (Forks Level)	kg	15137
		lbs	33362
	Rated Load (SAE J1197 - 50% FTSTL)	kg	7568
		lbs	16681
	Rated Load (CEN EN 474-3 Rough Terrain - 60% FTSTL)	kg	8586
		lbs	18924
	Rated Load (CEN EN 474-3 Firm and Level Ground - 80% FTSTL)	kg	8586
		lbs	18924
3	Maximum Overall Length	mm	10555
		in	415.6
4	Reach with Forks at Ground Level	mm	1397
		in	55.0
5	*Ground to Bottom of Tine at Minimum Height and Fork Level	mm	-91
		in	-3.6
6	Reach with Arms Horizontal and Forks Level	mm	1999
		in	78.7
7	Reach with Fork at Maximum Height	mm	915
		in	36.0
8	Ground to Top of Tine with Arms Horizontal and Fork Level	mm	2101
		in	82.7
9	Ground to Top of Tine at Maximum Height and Fork Level	mm	4590
		in	180.7
10	Overall Height of Fork at Full Lift (top of carriage to ground)	mm	5634
		in	221.8
11	Clearance at Full Lift and Max Dump	mm	2613
		in	102.9
12	Max Discharge Angle from Horizontal	deg	61
13	Overall Carriage Width	mm	2821
		in	111.1
14	Overall Carriage Height	mm	1129
		in	44.4
15	Outside Tine Width (max spread)	mm	2627
		in	103.4
16	Outside Tine Width (min spread)	mm	747
		in	29.4
	Tine Width (single tine)	mm	250.0
		in	9.8
	Tine Thickness	mm	85.0
		in	3.3
	Tine Capacity	kg	18700
		lbs	41215
	Operating Weight	kg	36576
		lbs	80613

*Negative values indicate below grade

980 IW HL Construction Fork, FUSION

108" Carriage 72" Tine
523-4199 523-4200

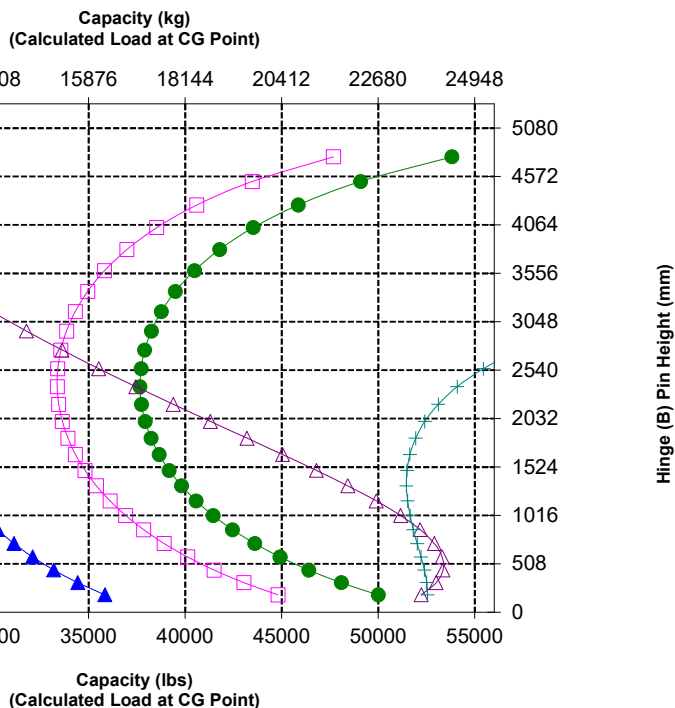
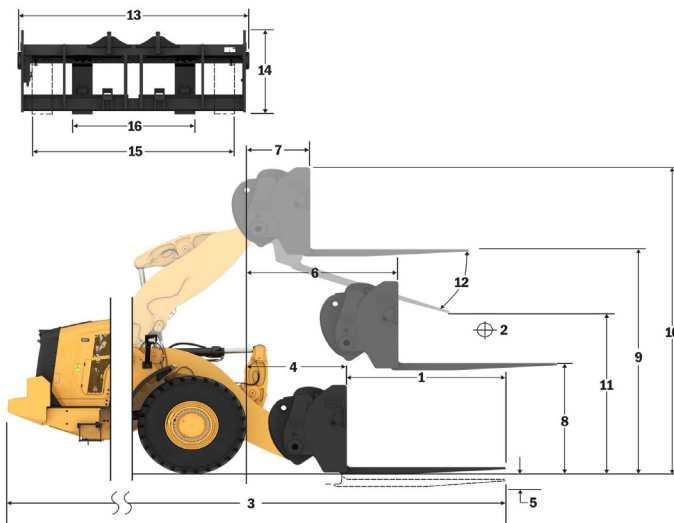

NOTE: Static tipping loads and operating weight are based on the following loader configuration: Brawler Smooth Solid Tires, Air Conditioning, Ride Control, Powertrain Guard, Full Fluids, Fuel Tank, Coolant, Lubricants, and Operator.

Specifications and ratings conform to the following standards: SAE* J1197, ISO 14397-1, CEN** EN 474-3.

The rated operating load for a loader equipped with a pallet fork is determined by:
SAE J1197: 50% of full turn static tipping load or hydraulic limit.
CEN EN 474-3: 60% of full turn static tipping load on rough terrain or hydraulic limit.
CEN EN 474-3: 80% of full turn static tipping load on firm and level ground or hydraulic limit.

*SAE - Society of Automotive Engineers
**CEN - European Committee for Standardization



WARNING: Do not exceed tine load capacity. Individual tine capacity is stamped on the side of each tine.

980 Waste & Scrap Handler Specifications

Fork Specifications

Fork Specifications

1	Tine Length	mm	2134
		in	84.0
2	Load Center	mm	1067
		in	42.0
	Static Tipping Load - Straight (Forks Level)	kg	17316
		lbs	38165
	Static Tipping Load - Articulated (Forks Level)	kg	15038
		lbs	33144
	Rated Load (SAE J1197 - 50% FTSTL)	kg	7519
		lbs	16572
	Rated Load (CEN EN 474-3 Rough Terrain - 60% FTSTL)	kg	7914
		lbs	17442
	Rated Load (CEN EN 474-3 Firm and Level Ground - 80% FTSTL)	kg	7914
		lbs	17442
3	Maximum Overall Length	mm	10655
		in	419.5
4	Reach with Forks at Ground Level	mm	1193
		in	47.0
5	*Ground to Bottom of Tine at Minimum Height and Fork Level	mm	-95
		in	-3.7
6	Reach with Arms Horizontal and Forks Level	mm	1826
		in	71.9
7	Reach with Fork at Maximum Height	mm	899
		in	35.4
8	Ground to Top of Tine with Arms Horizontal and Fork Level	mm	2104
		in	82.8
9	Ground to Top of Tine at Maximum Height and Fork Level	mm	4373
		in	172.2
10	Overall Height of Fork at Full Lift (top of carriage to ground)	mm	5412
		in	213.1
11	Clearance at Full Lift and Max Dump	mm	2251
		in	88.6
12	Max Discharge Angle from Horizontal	deg	55
13	Overall Carriage Width	mm	2821
		in	111.1
14	Overall Carriage Height	mm	1129
		in	44.4
15	Outside Tine Width (max spread)	mm	2627
		in	103.4
16	Outside Tine Width (min spread)	mm	747
		in	29.4
	Tine Width (single tine)	mm	250.0
		in	9.8
	Tine Thickness	mm	90.0
		in	3.5
	Tine Capacity	kg	17729
		lbs	39075
	Operating Weight	kg	36540
		lbs	80535

*Negative values indicate below grade

980 IW STD

Construction Fork, FUSION

108" Carriage

84" Tine

523-4199

523-4201

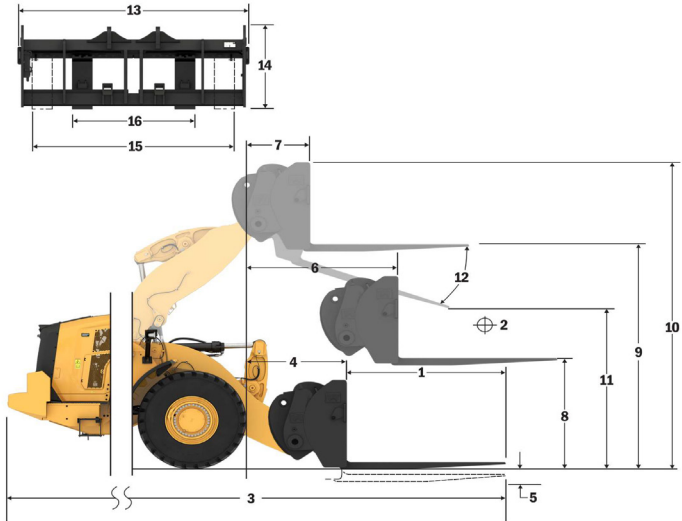

Capacity (kg)
(Calculated Load at CG Point)

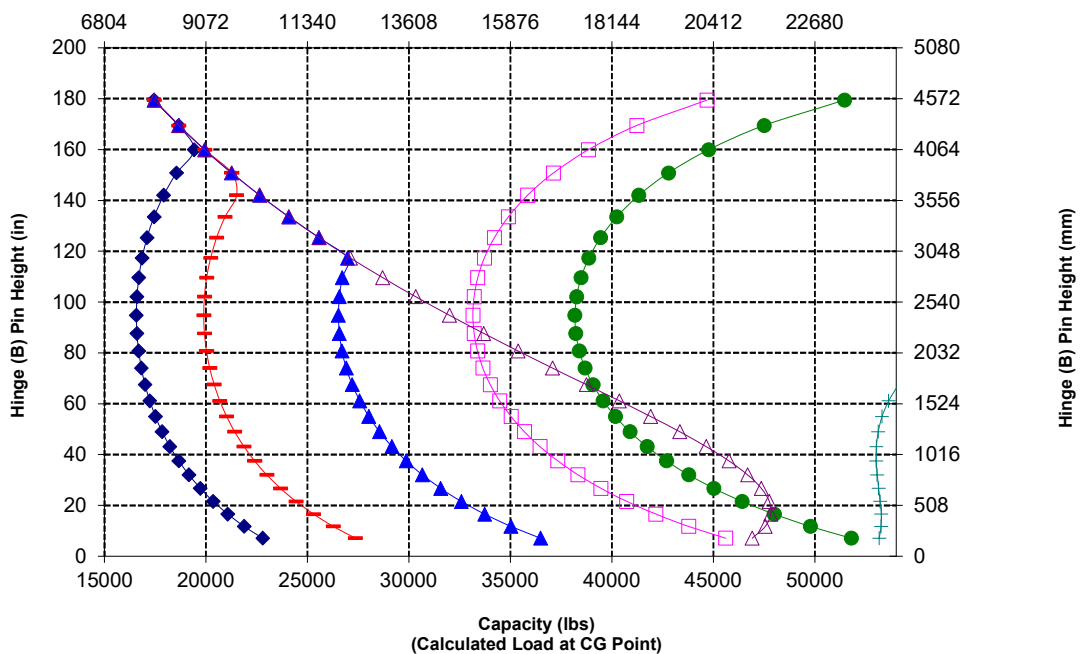

NOTE: Static tipping loads and operating weight are based on the following loader configuration: Brawler Smooth Solid Tires, Air Conditioning, Ride Control, Powertrain Guard, Full Fluids, Fuel Tank, Coolant, Lubricants, and Operator.

Specifications and ratings conform to the following standards: SAE* J1197, ISO 14397-1, CEN** EN 474-3.

The rated operating load for a loader equipped with a pallet fork is determined by:
SAE J1197: 50% of full turn static tipping load or hydraulic limit.
CEN EN 474-3: 60% of full turn static tipping load on rough terrain or hydraulic limit.
CEN EN 474-3: 80% of full turn static tipping load on firm and level ground or hydraulic limit.

*SAE - Society of Automotive Engineers
**CEN - European Committee for Standardization



WARNING: Do not exceed tine load capacity. Individual tine capacity is stamped on the side of each tine.

980 Waste & Scrap Handler Specifications

Fork Specifications

Fork Specifications

1	Tine Length	mm	2134
		in	84.0
2	Load Center	mm	1067
		in	42.0
	Static Tipping Load - Straight (Forks Level)	kg	16333
		lbs	35997
	Static Tipping Load - Articulated (Forks Level)	kg	14461
		lbs	31871
	Rated Load (SAE J1197 - 50% FTSTL)	kg	7230
		lbs	15936
	Rated Load (CEN EN 474-3 Rough Terrain - 60% FTSTL)	kg	7633
		lbs	16824
	Rated Load (CEN EN 474-3 Firm and Level Ground - 80% FTSTL)	kg	7633
		lbs	16824
3	Maximum Overall Length	mm	10863
		in	427.7
4	Reach with Forks at Ground Level	mm	1401
		in	55.2
5	*Ground to Bottom of Tine at Minimum Height and Fork Level	mm	-91
		in	-3.6
6	Reach with Arms Horizontal and Forks Level	mm	1999
		in	78.7
7	Reach with Fork at Maximum Height	mm	915
		in	36.0
8	Ground to Top of Tine with Arms Horizontal and Fork Level	mm	2106
		in	82.9
9	Ground to Top of Tine at Maximum Height and Fork Level	mm	4595
		in	180.9
10	Overall Height of Fork at Full Lift (top of carriage to ground)	mm	5634
		in	221.8
11	Clearance at Full Lift and Max Dump	mm	2346
		in	92.4
12	Max Discharge Angle from Horizontal	deg	61
13	Overall Carriage Width	mm	2821
		in	111.1
14	Overall Carriage Height	mm	1129
		in	44.4
15	Outside Tine Width (max spread)	mm	2627
		in	103.4
16	Outside Tine Width (min spread)	mm	747
		in	29.4
	Tine Width (single tine)	mm	250.0
		in	9.8
	Tine Thickness	mm	90.0
		in	3.5
	Tine Capacity	kg	17729
		lbs	39075
	Operating Weight	kg	36678
		lbs	80838

*Negative values indicate below grade

980 IW HL Construction Fork, FUSION

108" Carriage 84" Tine
523-4199 523-4201

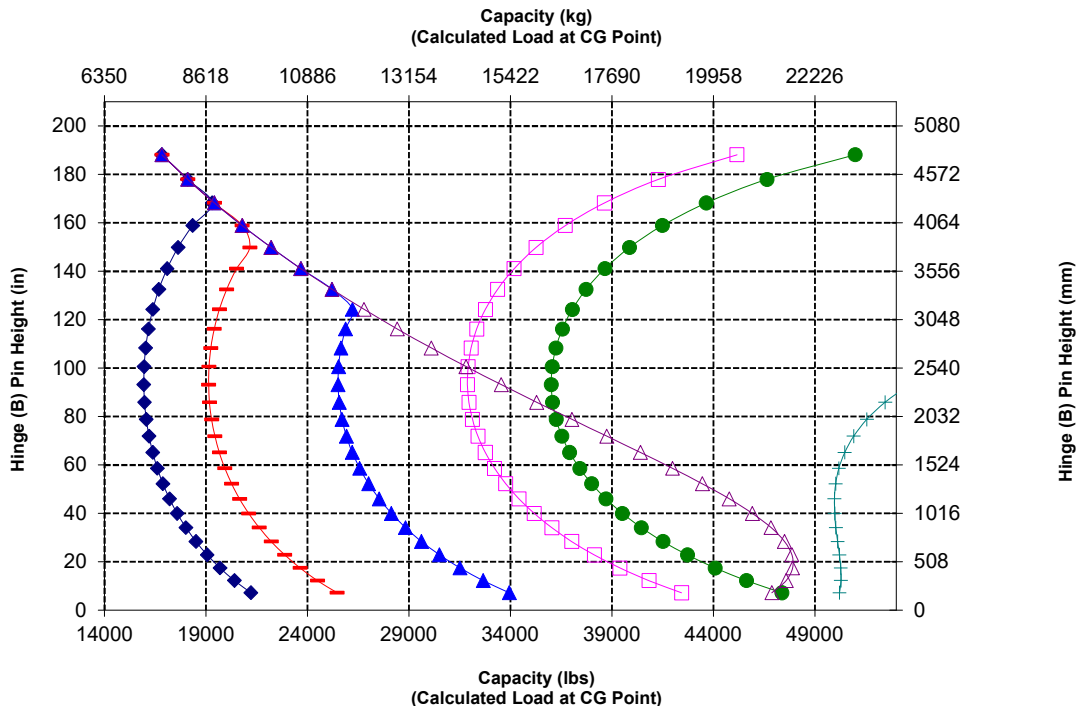
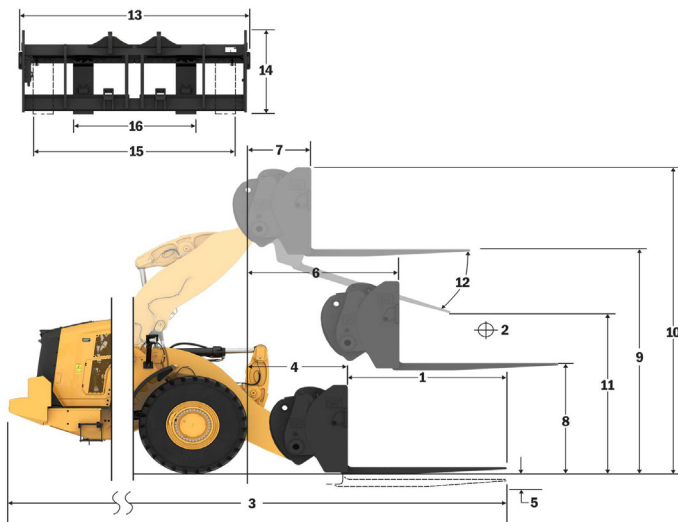

NOTE: Static tipping loads and operating weight are based on the following loader configuration: Brawler Smooth Solid Tires, Air Conditioning, Ride Control, Powertrain Guard, Full Fluids, Fuel Tank, Coolant, Lubricants, and Operator.

Specifications and ratings conform to the following standards: SAE* J1197, ISO 14397-1, CEN** EN 474-3.

The rated operating load for a loader equipped with a pallet fork is determined by:
SAE J1197: 50% of full turn static tipping load or hydraulic limit.
CEN EN 474-3: 60% of full turn static tipping load on rough terrain or hydraulic limit.
CEN EN 474-3: 80% of full turn static tipping load on firm and level ground or hydraulic limit.

*SAE - Society of Automotive Engineers
**CEN - European Committee for Standardization



WARNING: Do not exceed tine load capacity. Individual tine capacity is stamped on the side of each tine.

980 Waste & Scrap Handler Specifications

Fork Specifications

Fork Specifications

1	Tine Length	mm	2438
		in	96.0
2	Load Center	mm	1219
		in	48.0
	Static Tipping Load - Straight (Forks Level)	kg	16496
		lbs	36358
	Static Tipping Load - Articulated (Forks Level)	kg	14307
		lbs	31532
	Rated Load (SAE J1197 - 50% FTSTL)	kg	7041
		lbs	15518
	Rated Load (CEN EN 474-3 Rough Terrain - 60% FTSTL)	kg	7041
		lbs	15518
	Rated Load (CEN EN 474-3 Firm and Level Ground - 80% FTSTL)	kg	7041
		lbs	15518
3	Maximum Overall Length	mm	10964
		in	431.7
4	Reach with Forks at Ground Level	mm	1197
		in	47.1
5	*Ground to Bottom of Tine at Minimum Height and Fork Level	mm	-93
		in	-3.7
6	Reach with Arms Horizontal and Forks Level	mm	1831
		in	72.1
7	Reach with Fork at Maximum Height	mm	904
		in	35.6
8	Ground to Top of Tine with Arms Horizontal and Fork Level	mm	2106
		in	82.9
9	Ground to Top of Tine at Maximum Height and Fork Level	mm	4375
		in	172.2
10	Overall Height of Fork at Full Lift (top of carriage to ground)	mm	5412
		in	213.1
11	Clearance at Full Lift and Max Dump	mm	1998
		in	78.6
12	Max Discharge Angle from Horizontal	deg	55
13	Overall Carriage Width	mm	2821
		in	111.1
14	Overall Carriage Height	mm	1127
		in	44.4
15	Outside Tine Width (max spread)	mm	2629
		in	103.5
16	Outside Tine Width (min spread)	mm	747
		in	29.4
	Tine Width (single tine)	mm	250.0
		in	9.8
	Tine Thickness	mm	90.0
		in	3.5
	Tine Capacity	kg	15750
		lbs	34713
	Operating Weight	kg	36691
		lbs	80868

*Negative values indicate below grade

980 IW STD Construction Fork, FUSION

108" Carriage
523-4199

96" Tine
523-4202

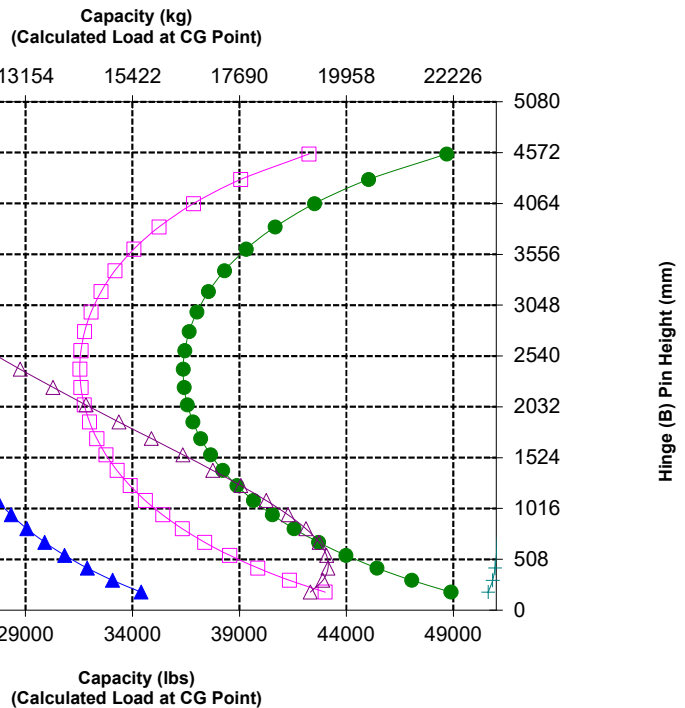
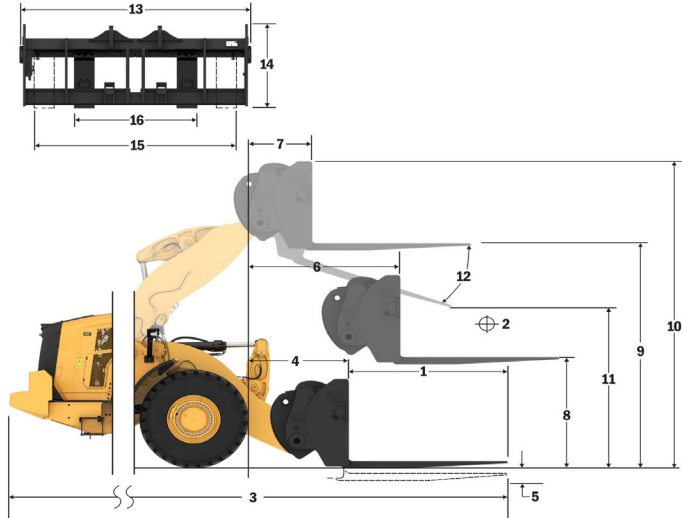

WARNING: Do not exceed tine load capacity. Individual tine capacity is stamped on the side of each tine.

980 Waste & Scrap Handler Specifications

Fork Specifications

Fork Specifications

1	Tine Length	mm	2438
		in	96.0
2	Load Center	mm	1219
		in	48.0
	Static Tipping Load - Straight (Forks Level)	kg	15576
		lbs	34328
	Static Tipping Load - Articulated (Forks Level)	kg	13773
		lbs	30356
	Rated Load (SAE J1197 - 50% FTSTL)	kg	6791
		lbs	14967
	Rated Load (CEN EN 474-3 Rough Terrain - 60% FTSTL)	kg	6791
		lbs	14967
	Rated Load (CEN EN 474-3 Firm and Level Ground - 80% FTSTL)	kg	6791
		lbs	14967
3	Maximum Overall Length	mm	11172
		in	439.8
4	Reach with Forks at Ground Level	mm	1405
		in	55.3
5	*Ground to Bottom of Tine at Minimum Height and Fork Level	mm	-89
		in	-3.5
6	Reach with Arms Horizontal and Forks Level	mm	2004
		in	78.9
7	Reach with Fork at Maximum Height	mm	920
		in	36.2
8	Ground to Top of Tine with Arms Horizontal and Fork Level	mm	2108
		in	83.0
9	Ground to Top of Tine at Maximum Height and Fork Level	mm	4597
		in	181.0
10	Overall Height of Fork at Full Lift (top of carriage to ground)	mm	5634
		in	221.8
11	Clearance at Full Lift and Max Dump	mm	2076
		in	81.7
12	Max Discharge Angle from Horizontal	deg	61
13	Overall Carriage Width	mm	2821
		in	111.1
14	Overall Carriage Height	mm	1127
		in	44.4
15	Outside Tine Width (max spread)	mm	2629
		in	103.5
16	Outside Tine Width (min spread)	mm	747
		in	29.4
	Tine Width (single tine)	mm	250.0
		in	9.8
	Tine Thickness	mm	90.0
		in	3.5
	Tine Capacity	kg	15750
		lbs	34713
	Operating Weight	kg	36829
		lbs	81171

*Negative values indicate below grade

980 IW HL Construction Fork, FUSION

108" Carriage 96" Tine
523-4199 523-4202

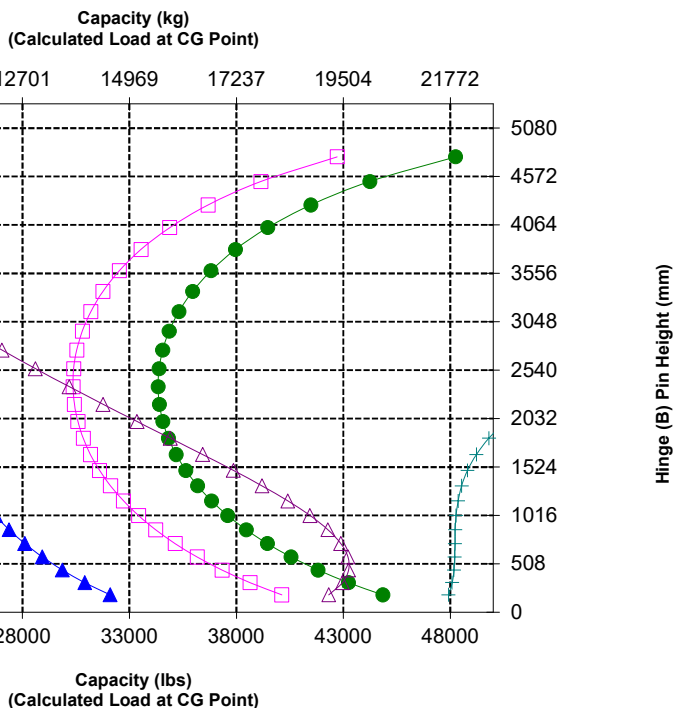
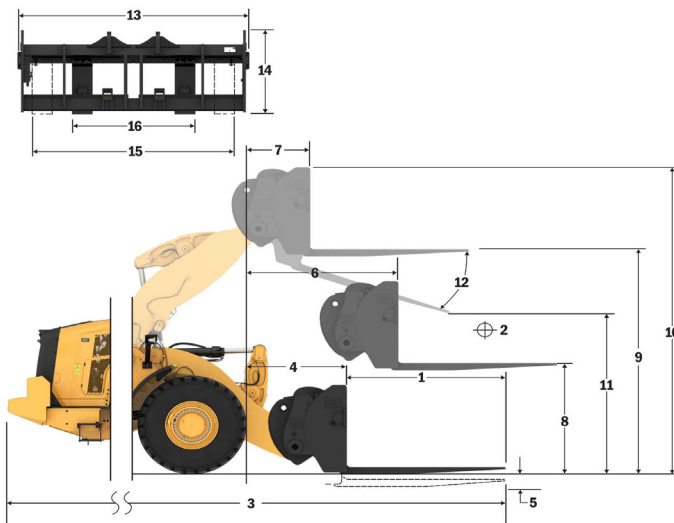

NOTE: Static tipping loads and operating weight are based on the following loader configuration: Brawler Smooth Solid Tires, Air Conditioning, Ride Control, Powertrain Guard, Full Fluids, Fuel Tank, Coolant, Lubricants, and Operator.

Specifications and ratings conform to the following standards: SAE* J1197, ISO 14397-1, CEN** EN 474-3.

The rated operating load for a loader equipped with a pallet fork is determined by:
SAE J1197: 50% of full turn static tipping load or hydraulic limit.
CEN EN 474-3: 60% of full turn static tipping load on rough terrain or hydraulic limit.
CEN EN 474-3: 80% of full turn static tipping load on firm and level ground or hydraulic limit.

*SAE - Society of Automotive Engineers
**CEN - European Committee for Standardization



WARNING: Do not exceed tine load capacity. Individual tine capacity is stamped on the side of each tine.



980

Forestry Machine

Millyard applications demand the additional performance, productivity, and safety that Cat forestry wheel loaders deliver.

Proven Reliability

- Cat C13 engine offers increased power density with a combination of proven electronic fuel and air systems.
- Thorough component design and machine validation processes result in unmatched reliability and uptime.

Durability

- Heavy-duty transmission and axles designed to handle extreme applications.
- Automatic planetary powershift (4F/4R) transmission features durable, long-lasting components.

Superior Fuel Efficiency & Productivity

- Forestry package includes additional counterweight, heavier rear frame, larger tilt cylinders, shorter tilt links, and an extreme service transmission to increase machine capacity over the base model.
- Optional variable pitch fan and high debris coolers minimize the potential for overheating and reduce downtime for radiator clean out in high debris applications.
- Optional 3rd valve auxiliary hydraulics to control work tools requiring the additional function.
- Extreme service powershift transmission with lock-up clutch increases fuel efficiency while delivering optimal performance.
- Single clutch and lock-to-lock shifting for faster acceleration and speed on grades.
- Automatic idle engine shutdown system significantly reduces idle time, overall operating hours, and fuel consumption.
- Optional limited slip differentials increase traction and reduce tire slip, lowering operating costs.
- Deeply integrated engine, power train, and hydraulic systems deliver unmatched productivity and fuel efficiency.

Safety Features

- Rearview camera enhances visibility behind the machine, helping you work safely and confidently.
- Optional multiview (360°) vision system helps the operator monitor the surroundings of the machine at all times.
- Optional Cat Detect radar technology enhances awareness by monitoring the working environment and alerts operators to hazards.
- Cab access with wide door, optional remote door opening, and stair-like steps add solid stability.
- Floor-to-ceiling windshield, large mirrors with integrated spot mirrors, and rearview camera provide industry leading all-around visibility.
- Optional access light and under-hood service light system to provide illuminated access to the machine and daily checks even in the dark.

Reduced Maintenance Time and Costs

- Extended fluid and filter change intervals reduce maintenance costs by up to 20%.
- Remote Troubleshoot can connect the machine to the dealer service department to help diagnose problems quickly so you can get back to work.
- Remote Flash works around your schedule to ensure your machine's software is up to date for optimal performance.
- The Cat App helps you manage fleet location, hours, and maintenance schedules; it also alerts you for required maintenance and allows you to request service from your local Cat dealer.
- One-piece tilting hood makes engine compartment access fast and easy.

Work in Comfort in the All New Cab

- Next-generation, easily adjustable seat and suspension for improved operator comfort. It comes in three trim levels and can be equipped with a 4-point harness.
- New in-cab dashboard and high-resolution touch display(s) are easy to use, intuitive, and user friendly.
- Sound suppression, seals, and viscous cab mounts decrease noise and vibration for a quieter work environment.
- The seat-mounted electro-hydraulic joystick steering system provides precision control and dramatically reduces arm fatigue, resulting in excellent comfort and accuracy. An HMU steering wheel is also available.

980 Forestry Machine Specifications

980 Forestry Machine Features

1. Larger tilt cylinders and optimized tilt links for increased load control in fork applications
2. Heavier rear frame and counterweight provide increased tipping loads in a millyard application
3. Extreme service transmission maintains durability
4. Optional window guarding to provide impact resistance to the glass
5. Optional 3rd function hydraulics provide auxiliary hydraulic control for work tools like millyard or logging forks
6. Wide range of millyard work tools

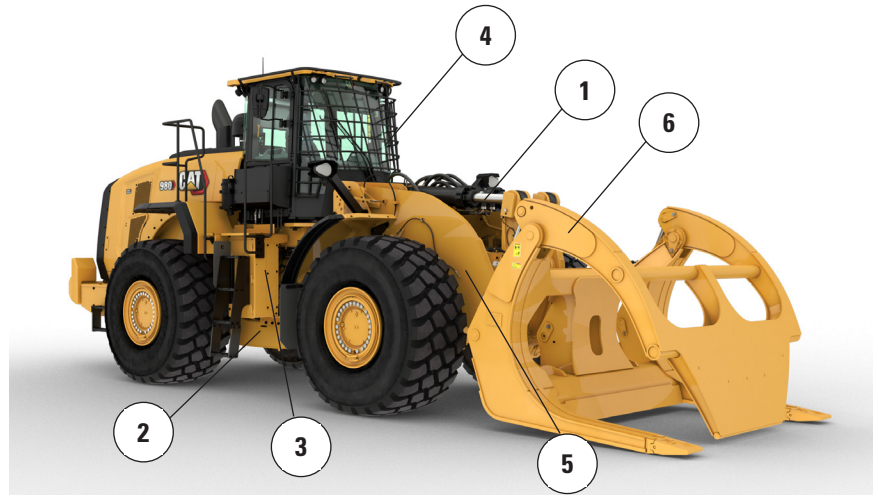

7. Optional variable pitch fan help to keep rear grill and cooling cores clean in high debris applications
8. Optional high debris/wide fin spacing cooling cores are less prone to plugging
9. Optional axle oil cooler provides lower axle oil temperatures in high braking applications
10. Optional engine and cab precleaners for use in high debris applications

980 Forestry Machine Specifications

Tire Options

Tire Brand	Bridgestone	Michelin	Bridgestone	Michelin	Maxam	Maxam
Tire Size	29.5R25	29.5R25	29.5R25	29.5R25	29.5R25	29.5R25
Tread Type	L-4	L-4	L-3	L-3	L-3	L-4
Tread Pattern	VSNT	XLDD1	VJT	XHA2	MS302	MS405DX
Width over Tires – Maximum (empty)*	3240 mm 10'8"	3258 mm 10'9"	3263 mm 10'9"	3270 mm 10'9"	3270 mm 10'9"	3256 mm 10'9"
Width over Tires – Maximum (loaded)*	3260 mm 10'9"	3302 mm 10'10"	3289 mm 10'10"	3296 mm 10'10"	3290 mm 10'10"	3282 mm 10'10"
Change in Vertical Dimensions (average of front and rear)		-7 mm -0.3"	-23 mm -0.9"	-40 mm -1.6"	-19 mm -0.8"	-33 mm -1.3"
Change in Horizontal Reach		-1 mm 0"	20 mm 0.8"	23 mm 0.9"	6 mm 0.2"	19 mm 0.7"
Change in Clearance Circle to Outside of Tires		42 mm 1.7"	29 mm 1.1"	36 mm 1.4"	30 mm 1.2"	22 mm 0.9"
Change in Clearance Circle to Inside of Tires		-42 mm -1.7"	-29 mm -1.1"	-36 mm -1.4"	-30 mm -1.2"	-22 mm -0.9"
Change in Operating Weight (without Ballast)		-156 kg -344 lb	-684 kg -1,508 lb	-700 kg -1,544 lb	-528 kg -1,164 lb	-388 kg -856 lb
Change in Static Tipping Load – Straight		-119 kg -262 lb	-520 kg -1,147 lb	-532 kg -1,174 lb	-402 kg -885 lb	-295 kg -651 lb
Change in Static Tipping Load – Articulated		-103 kg -228 lb	-453 kg -998 lb	-463 kg -1,022 lb	-350 kg -771 lb	-257 kg -566 lb
Rear Axle Oscillation Angle	±13 degrees	±13 degrees	±13 degrees	±13 degrees	±13 degrees	±13 degrees
Maximum Single-wheel Rise and Fall	549 mm 1'10"	549 mm 1'10"	549 mm 1'10"	549 mm 1'10"	549 mm 1'10"	549 mm 1'10"

*Width over tire bulge and includes tire growth.

Tire Brand	Michelin	Bridgestone	Bridgestone	Maxam
Tire Size	875/65R29	875/65R29	875/65R29	875/65R29
Tread Type	L-3	L-3	L-4	L-4
Tread Pattern	XHA2	VTS	VLTS	MS405DX
Width over Tires – Maximum (empty)*	3373 mm 11'1"	3341 mm 11'0"	3344 mm 11'0"	3357 mm 11'1"
Width over Tires – Maximum (loaded)*	3384 mm 11'2"	3359 mm 11'1"	3366 mm 11'1"	3382 mm 11'2"
Change in Vertical Dimensions (average of front and rear)	-25 mm -1"	-19 mm -0.8"	-16 mm -0.6"	-34 mm -1.3"
Change in Horizontal Reach	18 mm 0.7"	20 mm 0.8"	19 mm 0.7"	19 mm 0.7"
Change in Clearance Circle to Outside of Tires	124 mm 4.9"	99 mm 3.9"	106 mm 4.2"	122 mm 4.8"
Change in Clearance Circle to Inside of Tires	-124 mm -4.9"	-99 mm -3.9"	-106 mm -4.2"	-122 mm -4.8"
Change in Operating Weight (without Ballast)	-40 kg -88 lb	240 kg 529 lb	316 kg 697 lb	308 kg 679 lb
Change in Static Tipping Load – Straight	-30 kg -67 lb	183 kg 402 lb	240 kg 530 lb	234 kg 516 lb
Change in Static Tipping Load – Articulated	-26 kg -58 lb	159 kg 350 lb	209 kg 461 lb	204 kg 450 lb
Rear Axle Oscillation Angle	±8 degrees	±8 degrees	±8 degrees	±8 degrees
Maximum Single-wheel Rise and Fall	340 mm 1'1"	340 mm 1'1"	340 mm 1'1"	340 mm 1'1"

*Width over tire bulge and includes tire growth.

980 Forestry Machine Specifications

Fork Specifications

Fork Specifications

1	Tine Length	mm	2438
		in	96.0
2	Load Center	mm	1219
		in	48.0
	Static Tipping Load - Straight (Forks Level)	kg	15352
		lbs	33835
	Static Tipping Load - Articulated (Forks Level)	kg	13533
		lbs	29826
	Rated Load (SAE J1197 - 50% FTSTL)	kg	6766
		lbs	14913
	Rated Load (CEN EN 474-3 Rough Terrain - 60% FTSTL)	kg	8120
		lbs	17896
	Rated Load (CEN EN 474-3 Firm and Level Ground - 80% FTSTL)	kg	10826
		lbs	23861
3	Maximum Overall Length	mm	11174
		in	439.9
4	Reach with Forks at Ground Level	mm	1318
		in	51.9
5	*Ground to Bottom of Tine at Minimum Height and Fork Level	mm	-143
		in	-5.6
6	Reach with Arms Horizontal and Forks Level	mm	1840
		in	72.4
7	Reach with Fork at Maximum Height	mm	913
		in	35.9
8	Ground to Top of Tine with Arms Horizontal and Fork Level	mm	2169
		in	85.4
9	Ground to Top of Tine at Maximum Height and Fork Level	mm	4438
		in	174.7
10	Overall Height of Fork at Full Lift (top of carriage to ground)	mm	5810
		in	228.7
11	Clearance at Full Lift and Max Dump	mm	2165
		in	85.3
12	Max Discharge Angle from Horizontal	deg	47
13	Overall Carriage Width	mm	2751
		in	108.3
14	Overall Carriage Height	mm	1575
		in	62.0
15	Outside Tine Width (max spread)	mm	2671
		in	105.1
16	Outside Tine Width (min spread)	mm	849
		in	33.4
	Tine Width (single tine)	mm	88.9
		in	3.5
	Tine Thickness	mm	203.2
		in	8.0
	Tine Capacity	kg	11068
		lbs	24393
	Operating Weight	kg	31500
		lbs	69426

*Negative values indicate below grade

980 LOG

Pallet, Pin-ON

96" Tine
473-9104

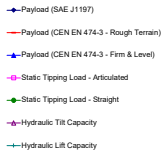
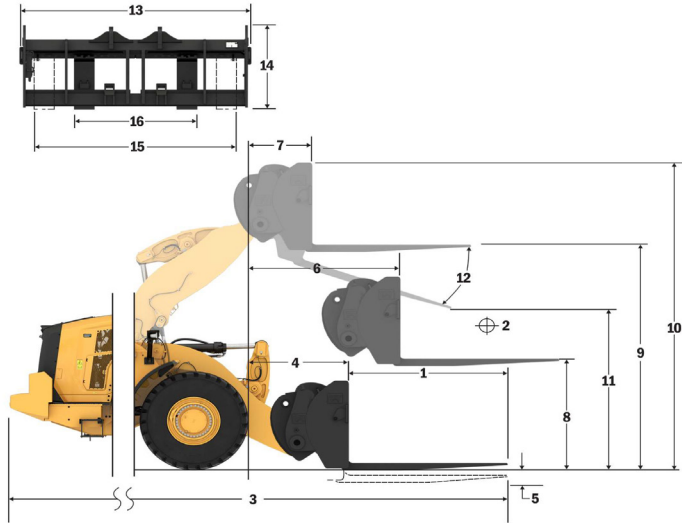

NOTE: Static tipping loads and operating weight are based on the following loader configuration: Bridgestone * VSNT L4 Tires, Air Conditioning, Ride Control, Powertrain Guard, Full Fluids, Fuel Tank, Coolant, Lubricants, and Operator.

Specifications and ratings conform to the following standards: SAE* J1197, ISO 14397-1, CEN** EN 474-3.

The rated operating load for a loader equipped with a pallet fork is determined by:
SAE J1197: 50% of full turn static tipping load or hydraulic limit.
CEN EN 474-3: 60% of full turn static tipping load on rough terrain or hydraulic limit.
CEN EN 474-3: 80% of full turn static tipping load on firm and level ground or hydraulic limit.

*SAE - Society of Automotive Engineers
**CEN - European Committee for Standardization

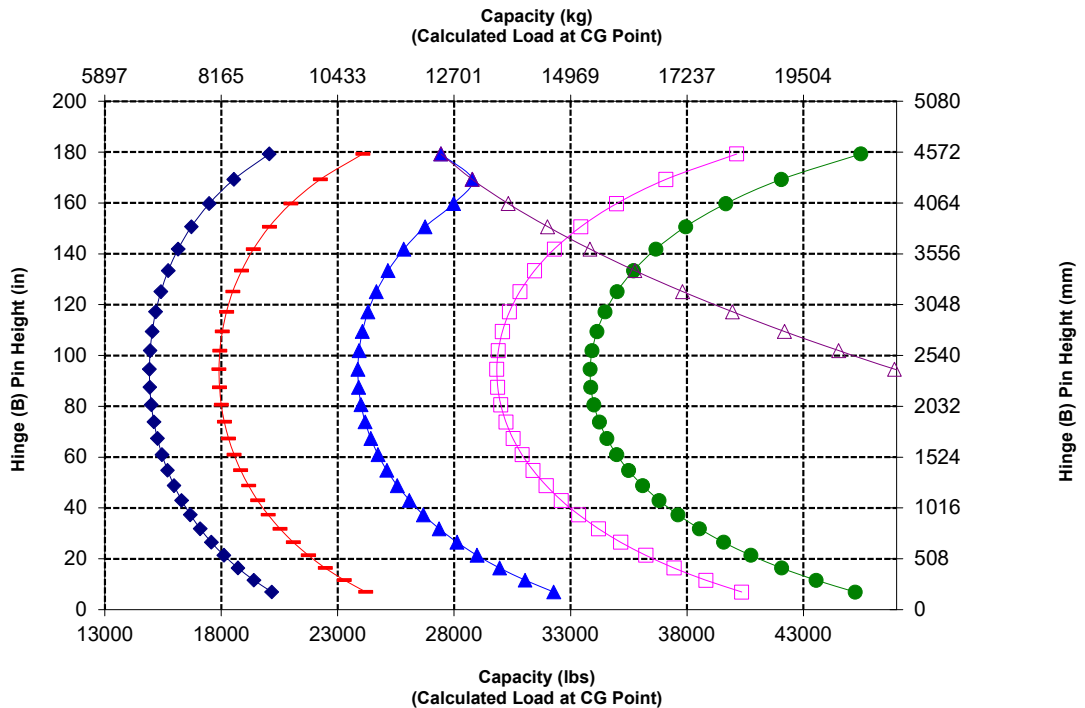

WARNING: Do not exceed tine load capacity. Individual tine capacity is stamped on the side of each tine.

980 Forestry Machine Specifications

Fork Specifications

Fork Specifications

1	Tine Length	mm	1829
		in	72.0
2	Load Center	mm	914
		in	36.0
	Static Tipping Load - Straight (Forks Level)	kg	16872
		lbs	37187
	Static Tipping Load - Articulated (Forks Level)	kg	14904
		lbs	32849
	Rated Load (SAE J1197 - 50% FTSTL)	kg	7452
		lbs	16424
	Rated Load (CEN EN 474-3 Rough Terrain - 60% FTSTL)	kg	8943
		lbs	19709
	Rated Load (CEN EN 474-3 Firm and Level Ground - 80% FTSTL)	kg	11923
		lbs	26279
3	Maximum Overall Length	mm	10568
		in	416.1
4	Reach with Forks at Ground Level	mm	1322
		in	52.1
5	*Ground to Bottom of Tine at Minimum Height and Fork Level	mm	-149
		in	-5.9
6	Reach with Arms Horizontal and Forks Level	mm	1840
		in	72.4
7	Reach with Fork at Maximum Height	mm	913
		in	35.9
8	Ground to Top of Tine with Arms Horizontal and Fork Level	mm	2163
		in	85.2
9	Ground to Top of Tine at Maximum Height and Fork Level	mm	4432
		in	174.5
10	Overall Height of Fork at Full Lift (top of carriage to ground)	mm	5810
		in	228.7
11	Clearance at Full Lift and Max Dump	mm	2607
		in	102.7
12	Max Discharge Angle from Horizontal	deg	47
13	Overall Carriage Width	mm	2751
		in	108.3
14	Overall Carriage Height	mm	1581
		in	62.3
15	Outside Tine Width (max spread)	mm	2671
		in	105.1
16	Outside Tine Width (min spread)	mm	849
		in	33.4
	Tine Width (single tine)	mm	88.9
		in	3.5
	Tine Thickness	mm	203.2
		in	8.0
	Tine Capacity	kg	14742
		lbs	32491
	Operating Weight	kg	31268
		lbs	68915

*Negative values indicate below grade

980 LOG

Pallet, Pin-ON

72" Tine
473-9106

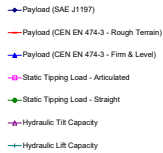
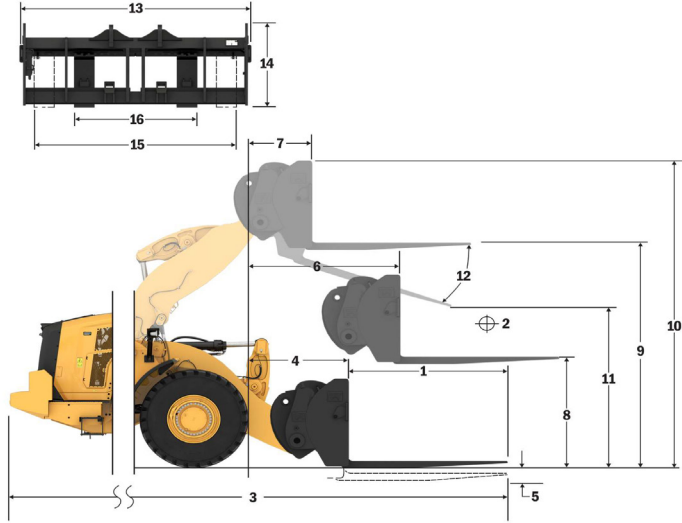

NOTE: Static tipping loads and operating weight are based on the following loader configuration: Bridgestone * VSNT L4 Tires, Air Conditioning, Ride Control, Powertrain Guard, Full Fluids, Fuel Tank, Coolant, Lubricants, and Operator.

Specifications and ratings conform to the following standards: SAE* J1197, ISO 14397-1, CEN** EN 474-3.

The rated operating load for a loader equipped with a pallet fork is determined by:
SAE J1197: 50% of full turn static tipping load or hydraulic limit.
CEN EN 474-3: 60% of full turn static tipping load on rough terrain or hydraulic limit.
CEN EN 474-3: 80% of full turn static tipping load on firm and level ground or hydraulic limit.

*SAE - Society of Automotive Engineers

**CEN - European Committee for Standardization

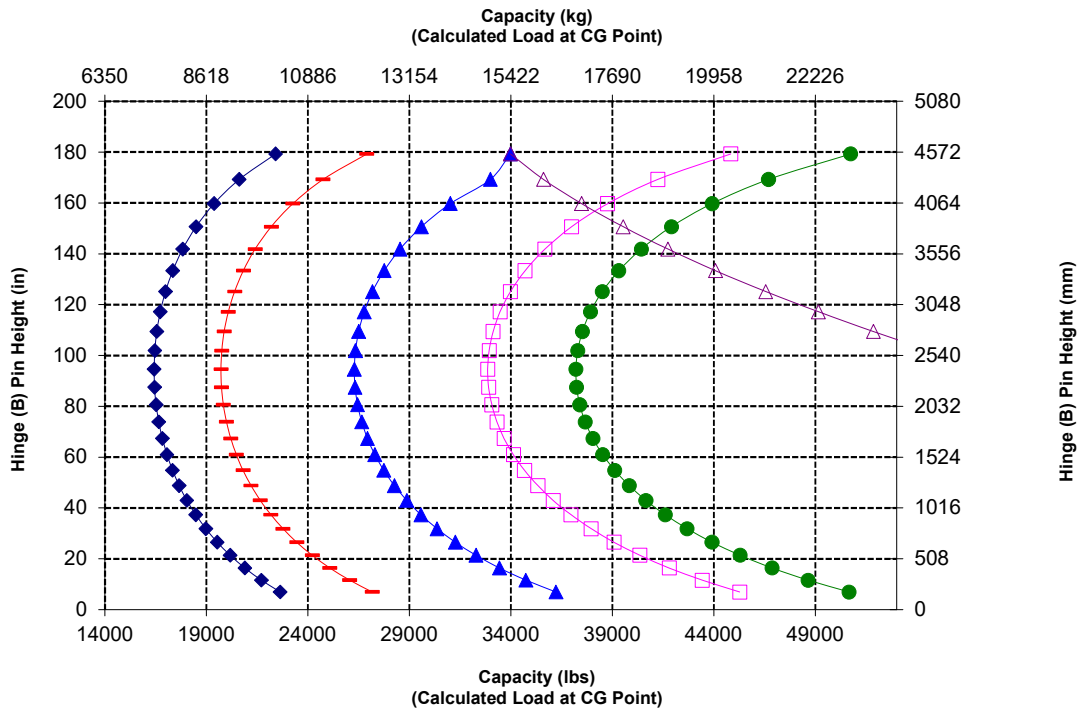

WARNING: Do not exceed tine load capacity. Individual tine capacity is stamped on the side of each tine.

980 Forestry Machine Specifications

Fork Specifications

Fork Specifications

1	Tine length	mm	1829
		in	72.0
2	Fork width	mm	2777
		in	109.3
	End area	m ²	1.69
		ft ²	18
3	Inside Height (only applies to double top clamp)	mm	0
		in	0
4	Min. opening (only applies to millyard forks)	mm	555
		in	22
	Operating Weight	kg	32765
		lbs	72234
5	Distance inside of tine tips	mm	2215
		in	87
	Static tipping load, articulated Fork level	kg	15998
		lbs	35268.4
	Static tipping load, straight Fork level	kg	18310
		lbs	40366.2
6	Max. height of fork (w/clamp open if applicable)	mm	3107
		in	122.3
7	Clearance w/full lift, 45 deg dump (if max. dump < 45)	mm	2982
		in	117.4
8	Clearance @ full lift fork level	mm	4301
		in	169.3
9	Reach w/full lift, 45 deg dump (if max. dump < 45)	mm	1600
		in	63.0
10	Reach w/lift arm horizontal and fork level	mm	3283
		in	129.2
11	*Ground to Bottom of Tool at Minimum Height and Tool Level	mm	-77
		in	-3.0
12	Width over tines	mm	2741
		in	107.9
13	Reach @ ground level	mm	2566
		in	101
14	Max. opening across tine and clamp	mm	2926
		in	115.2
15	Overall height of fork @ full lift and clamp open	mm	7408
		in	291.7
16	Overall length Tip of tine to rear of machine	mm	9983
		in	393.0
17	Clearance @ full lift and max. dump Discharge (if < 45)	mm	2939
		in	115.7
18	Clearance w/horizontal lift arms and fork level	mm	2032.4
		in	80.0
19	Reach @ full lift and fork level	mm	2356.0
		in	92.8
20	Max. discharge angle from horizontal	deg	47
		rad	0.8

*Negative values indicate below grade

980 LOG

Millyard, Pin-On

72" Tine

507-6128

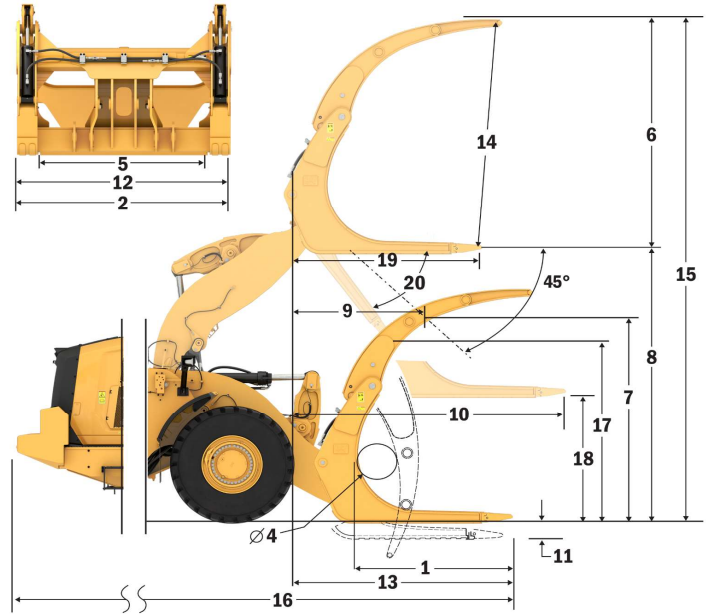

Capacity (kg)
(Calculated Load at CG Point)

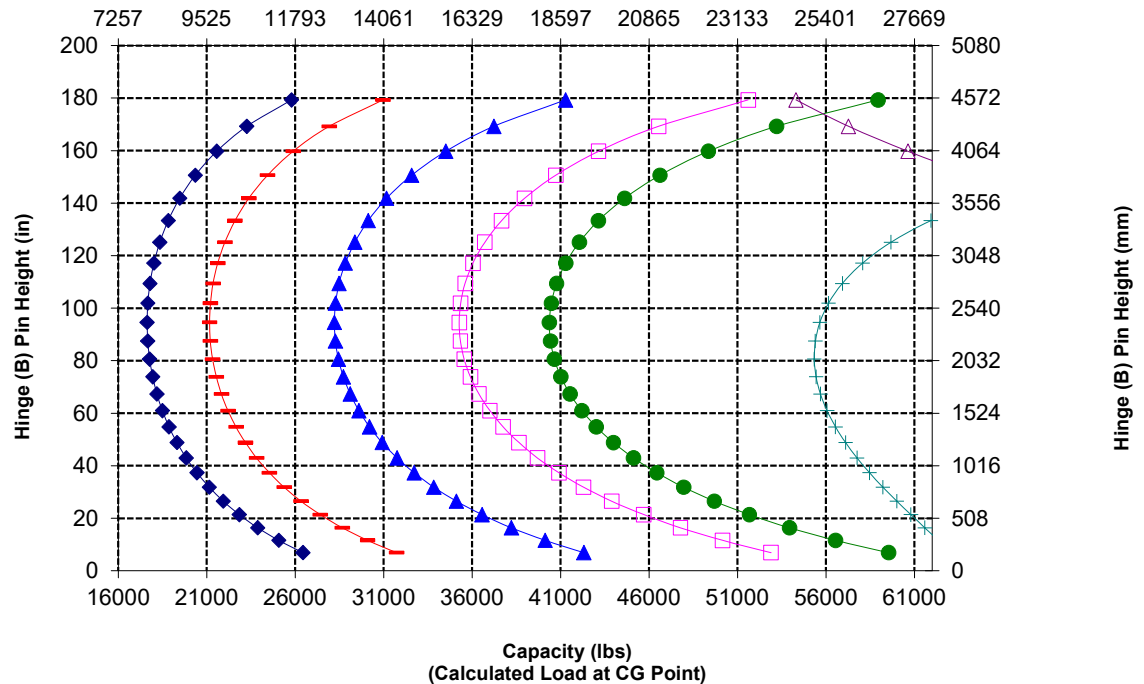

980 Forestry Machine Specifications

Fork Specifications

Fork Specifications

1	Tine length	mm	1826
		in	71.9
2	Fork width	mm	2802
		in	110.3
	End area	m ²	2.43
		ft ²	26
3	Inside Height (only applies to double top clamp)	mm	1540
		in	61
4	Min. opening (only applies to millyard forks)	mm	N/A
		in	N/A
	Operating Weight	kg	31970
		lbs	70481
5	Distance inside of tine tips	mm	2256
		in	89
	Static tipping load, articulated Fork level	kg	15920
		lbs	35097.5
	Static tipping load, straight Fork level	kg	18102
		lbs	39906.6
6	Max. height of fork (w/clamp open if applicable)	mm	3394
		in	133.6
7	Clearance w/full lift, 45 deg dump (if max. dump <= 45)	mm	2979
		in	117.3
8	Clearance @ full lift fork level	mm	4301
		in	169.3
9	Reach w/full lift, 45 deg dump (if max. dump <= 45)	mm	1603
		in	63.1
10	Reach w/lift arm horizontal and fork level	mm	3287
		in	129.4
11	*Ground to Bottom of Tool at Minimum Height and Tool Level	mm	-77
		in	-3.0
12	Width over tines	mm	2752
		in	108.4
13	Reach @ ground level	mm	2570
		in	101
14	Max. opening across tine and clamp	mm	2936
		in	115.6
15	Overall height of fork @ full lift and clamp open	mm	7695
		in	303.0
16	Overall length Tip of tine to rear of machine	mm	9987
		in	393.2
17	Clearance @ full lift and max. dump Discharge (if <= 45)	mm	2936
		in	115.6
18	Clearance w/horizontal lift arms and fork level	mm	2032.2
		in	80.0
19	Reach @ full lift and fork level	mm	2359.9
		in	92.9
20	Max. discharge angle from horizontal	deg	47
		rad	0.8

*Negative values indicate below grade

980 LOG

Logging, Pin-On

72" Tine

383-1822

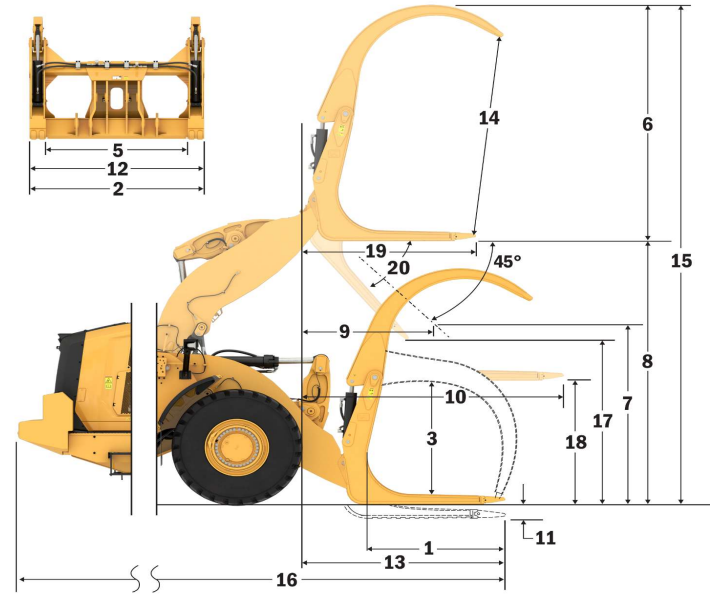

Capacity (kg)
(Calculated Load at CG Point)

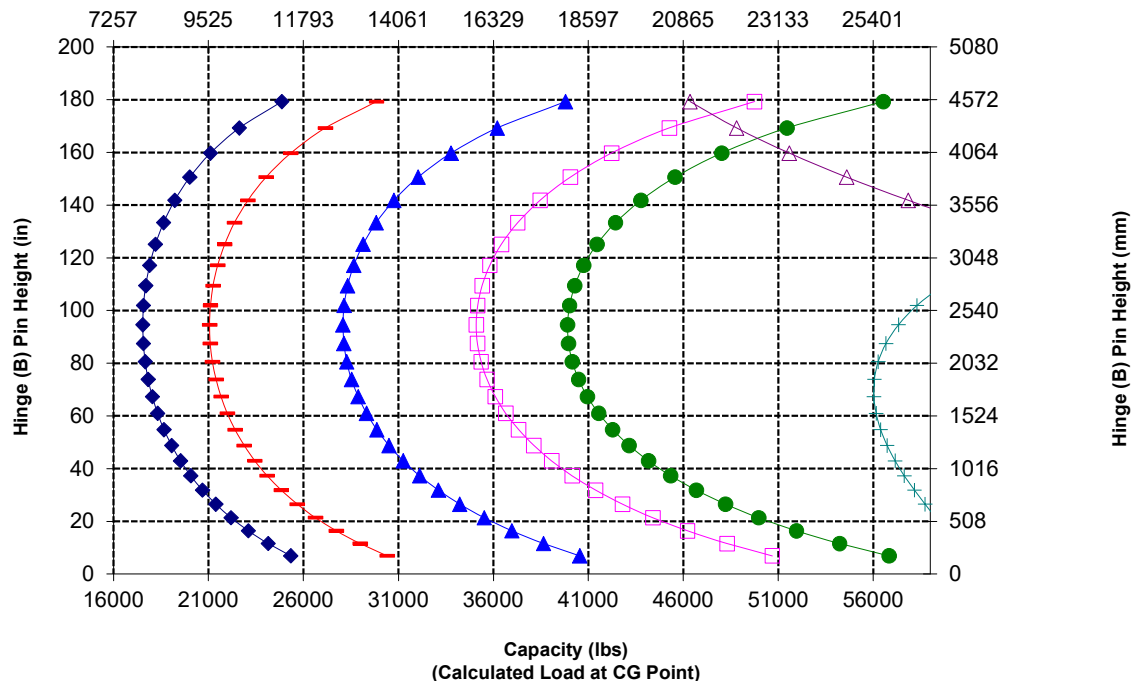



980

Steel Mill

Steel mill package is designed for the challenging work environment of steel mills and slag handling applications, incorporating an added level of safety.

Proven Reliability

- Cat C13 engine offers increased power density with a combination of proven electronic fuel and air systems.
- Thorough component design and machine validation processes result in unmatched reliability and uptime.

Durability

- Steel mill package adds additional steel guards all around the machine to protect your investment.
- Hydraulic hoses and electrical harnesses outside of the frame are insulated and wrapped with stainless steel braiding.
- Heavy-duty hinge pins with a cross hatch design and high temp bushings are purpose built
- Heavy-duty steel cable lower steps stand up to the harshest of conditions
- Heavy-duty transmission and axles designed to handle extreme applications.
- Automatic planetary powershift (4F/4R) transmission features durable, long-lasting components.

Superior Fuel Efficiency & Productivity

- Powershift transmission with lock-up clutch increases fuel efficiency while delivering optimal performance.
- Single clutch and lock-to-lock shifting for faster acceleration and speed on grades.
- Automatic idle engine shutdown system significantly reduces idle time, overall operating hours, and fuel consumption.
- Optional limited slip differentials increase traction and reduce tire slip, lowering operating costs.
- Deeply integrated engine, power train, and hydraulic systems deliver unmatched productivity and fuel efficiency.

Safety Features

- Ground-level parking brake override & engine shutdown switches for emergency machine retrieval.
- Optional rear egress stairs allows for another point of machine exit for the operator.
- In-cab parking brake and transmission override controls provide an added level of safety for a steel mill application.
- Rearview camera enhances visibility behind the machine, helping you work safely and confidently.
- Cab access with wide door, optional remote door opening, and stair-like steps add solid stability.
- Floor-to-ceiling windshield, large mirrors with integrated spot mirrors, and rearview camera provide industry leading all-around visibility.

Reduced Maintenance Time and Costs

- Extended fluid and filter change intervals reduce maintenance costs by up to 20%.
- Remote Troubleshoot can connect the machine to the dealer service department to help diagnose problems quickly so you can get back to work.
- Remote Flash works around your schedule to ensure your machine's software is up to date for optimal performance.
- The Cat App helps you manage fleet location, hours, and maintenance schedules; it also alerts you for required maintenance and allows you to request service from your local Cat dealer.
- One-piece tilting hood makes engine compartment access fast and easy.

Work in Comfort in the All New Cab

- Next-generation, easily adjustable seat and suspension for improved operator comfort. It comes in three trim levels and can be equipped with a 4-point harness.
- New in-cab dashboard and high-resolution touch display(s) are easy to use, intuitive, and user friendly.
- Sound suppression, seals, and viscous cab mounts decrease noise and vibration for a quieter work environment.
- The seat-mounted electro-hydraulic joystick steering system provides precision control and dramatically reduces arm fatigue, resulting in excellent comfort and accuracy. An HMU steering wheel is also available.

980 Steel Mill Specifications

980 Steel Mill Features

1. Hydraulic hoses and electrical harness are wrapped with a thermal sleeve
2. Hoses and harnesses outside of the frame have an additional stainless-steel sleeve applied
3. Added steel guards include crankcase, power train, front frame, hitch, steering cylinder, service center, cab, platform, implement valve cover, and tilt cylinder
4. Extreme service transmission
5. Heavy-duty hinge pins with a cross hatch design and high temp bushings are purpose built
6. Front lights are guarded and positioned close to the frame for added protection

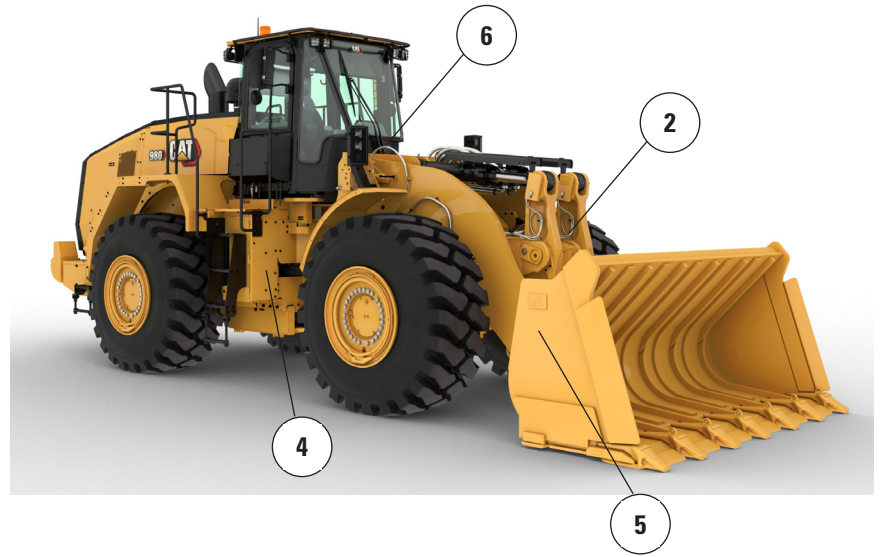

7. Ground-level parking brake override & engine shutdown switches
8. Optional rear egress with fire suppression left hand mounting point available
9. Steel roof cap and steel mirrors integrated into the cab
10. In-cab parking brake and transmission override controls
11. In-cab secondary engine start
12. Non-bonded flat front cab glass allows for easy replacement
13. Eco-Safe FR46 hydraulic fluid available from the factory
14. Optional steel hood
15. Heavy-duty steel cable steps

Tire Options

Tire Brand	Bridgestone	Michelin	Michelin	Michelin
Tire Size	29.5-25	29.5-25	29.5-25	29.5-25
Tread Type	L-4	L-4	L-5	L-5
Tread Pattern	VSNT	XLDD1	XLDD2	XMINED2
Width over Tires – Maximum (empty)*	3240 mm 10'8"	3258 mm 10'9"	3256 mm 10'9"	3275 mm 10'9"
Width over Tires – Maximum (loaded)*	3260 mm 10'9"	3302 mm 10'10"	3296 mm 10'10"	3294 mm 10'10"
Change in Vertical Dimensions (average of front and rear)		-7 mm -0.3"	-6 mm -0.2"	5 mm 0.2"
Change in Horizontal Reach		-1 mm 0"	3 mm 0.1"	3 mm 0.1"
Change in Clearance Circle to Outside of Tires		42 mm 1.7"	36 mm 1.4"	34 mm 1.3"
Change in Clearance Circle to Inside of Tires		-42 mm -1.7"	-36 mm -1.4"	-34 mm -1.3"
Change in Operating Weight (without Ballast)		-156 kg -344 lb	208 kg 459 lb	532 kg 1173 lb
Change in Static Tipping Load – Straight		-119 kg -262 lb	158 kg 349 lb	405 kg 892 lb
Change in Static Tipping Load – Articulated		-103 kg -228 lb	138 kg 304 lb	352 kg 777 lb
Rear Axle Oscillation Angle	±8 degrees	±8 degrees	±8 degrees	±8 degrees
Maximum Single-wheel Rise and Fall	340 mm 1'1"	340 mm 1'1"	340 mm 1'1"	340 mm 1'1"

*Width over tire bulge and includes tire growth.

Tire Brand	Bridgestone	Michelin	Bridgestone	Bridgestone
Tire Size	29.5R25	29.5R25	29.5R25	29.5R25
Tread Type	L-3	L-4	L-5	L-5
Tread Pattern	VJT	VSNT	VSDT	VSDL
Width over Tires – Maximum (empty)*	3263 mm 10'9"	3270 mm 10'9"	3272 mm 10'9"	3250 mm 10'8"
Width over Tires – Maximum (loaded)*	3289 mm 10'10"	3296 mm 10'10"	3301 mm 10'10"	3275 mm 10'9"
Change in Vertical Dimensions (average of front and rear)	-23 mm -0.9"	-40 mm -1.6"	4 mm 0.1"	20 mm 0.8"
Change in Horizontal Reach	20 mm 0.8"	23 mm 0.9"	0 mm 0"	-10 mm -0.4"
Change in Clearance Circle to Outside of Tires	29 mm 1.1"	36 mm 1.4"	41 mm 1.6"	15 mm 0.6"
Change in Clearance Circle to Inside of Tires	-29 mm -1.1"	-36 mm -1.4"	-41 mm -1.6"	-15 mm -0.6"
Change in Operating Weight (without Ballast)	-684 kg -1508 lb	-700 kg -1,544 lb	500 kg 1,103 lb	708 kg 1,561 lb
Change in Static Tipping Load – Straight	-520 kg -1147 lb	-532 kg -1,174 lb	380 kg 838 lb	538 kg 1,187 lb
Change in Static Tipping Load – Articulated	-453 kg -998 lb	-463 kg -1,022 lb	331 kg 730 lb	469 kg 1,033 lb
Rear Axle Oscillation Angle	±8 degrees	±8 degrees	±8 degrees	±8 degrees
Maximum Single-wheel Rise and Fall	340 mm 1'1"	340 mm 1'1"	340 mm 1'1"	340 mm 1'1"

*Width over tire bulge and includes tire growth.

980 Steel Mill Specifications

Tire Options

Tire Brand	Maxam	Maxam	Maxam	Brawler
Tire Size	29.5-25	29.5-25	29.5-25	29.5-25
Tread Type	L-3	L-4	L-5	L-3
Tread Pattern	MS302	MS405DX	MS503	XHA2
Width over Tires – Maximum (empty)*	3270 mm 10'9"	3256 mm 10'9"	3268 mm 10'9"	3227 mm 10'8"
Width over Tires – Maximum (loaded)*	3290 mm 10'10"	3282 mm 10'10"	3304 mm 10'11"	3230 mm 10'8"
Change in Vertical Dimensions (average of front and rear)	-19 mm -0.8"	-33 mm -1.3"	-6 mm -0.2"	9 mm 0.4"
Change in Horizontal Reach	6 mm 0.2"	19 mm 0.7"	-3 mm -0.1"	30 mm 1.2"
Change in Clearance Circle to Outside of Tires	30 mm 1.2"	22 mm 0.9"	44 mm 1.7"	-30 mm -1.2"
Change in Clearance Circle to Inside of Tires	-30 mm -1.2"	-22 mm -0.9"	-44 mm -1.7"	30 mm 1.2"
Change in Operating Weight (without Ballast)	-528 kg -1,164 lb	-388 kg -856 lb	252 kg 556 lb	5772 kg 12,727 lb
Change in Static Tipping Load – Straight	-402 kg -885 lb	-295 kg -651 lb	192 kg 423 lb	4390 kg 9,679 lb
Change in Static Tipping Load – Articulated	-350 kg -771 lb	-257 kg -566 lb	167 kg 368 lb	3821 kg 8,425 lb
Rear Axle Oscillation Angle	±8 degrees	±8 degrees	±8 degrees	±8 degrees
Maximum Single-wheel Rise and Fall	340 mm 1'1"	340 mm 1'1"	340 mm 1'1"	340 mm 1'1"

*Width over tire bulge and includes tire growth.

Tire Brand	Michelin	Bridgestone	Bridgestone	Maxam
Tire Size	875/65R29	875/65R29	875/65R29	875/65R29
Tread Type	L-3	L-3	L-4	L-4
Tread Pattern	XHA2	VTS	VLTS	MS405DX
Width over Tires – Maximum (empty)*	3373 mm 11'1"	3341 mm 11'0"	3344 mm 11'0"	3357 mm 11'1"
Width over Tires – Maximum (loaded)*	3384 mm 11'2"	3359 mm 11'1"	3366 mm 11'1"	3382 mm 11'2"
Change in Vertical Dimensions (average of front and rear)	-25 mm -1"	-19 mm -0.8"	-16 mm -0.6"	-34 mm -1.3"
Change in Horizontal Reach	18 mm 0.7"	20 mm 0.8"	19 mm 0.7"	19 mm 0.7"
Change in Clearance Circle to Outside of Tires	124 mm 4.9"	99 mm 3.9"	106 mm 4.2"	122 mm 4.8"
Change in Clearance Circle to Inside of Tires	-124 mm -4.9"	-99 mm -3.9"	-106 mm -4.2"	-122 mm -4.8"
Change in Operating Weight (without Ballast)	-40 kg -88 lb	240 kg 529 lb	316 kg 697 lb	308 kg 679 lb
Change in Static Tipping Load – Straight	-30 kg -67 lb	183 kg 402 lb	240 kg 530 lb	234 kg 516 lb
Change in Static Tipping Load – Articulated	-26 kg -58 lb	159 kg 350 lb	209 kg 461 lb	204 kg 450 lb
Rear Axle Oscillation Angle	±8 degrees	±8 degrees	±8 degrees	±8 degrees
Maximum Single-wheel Rise and Fall	340 mm 1'1"	340 mm 1'1"	340 mm 1'1"	340 mm 1'1"

*Width over tire bulge and includes tire growth.

Operating Specifications – Buckets

Linkage		Standard Linkage
Bucket Type		Slag – Pin-On
Edge Type		Teeth and Segments
Capacity – Rated	m ³	3.80
	yd ³	5.00
Capacity – Rated at 110% Fill Factor	m ³	4.20
	yd ³	5.50
Width	mm	3394
	ft/in	11'1"
16 † Dump Clearance at Maximum Lift and 45° Discharge	mm	3206
	ft/in	10'6"
17 † Reach at Maximum Lift and 45° Discharge	mm	1493
	ft/in	4'10"
Reach at Level Lift Arm and Bucket Level	mm	3021
	ft/in	9'10"
A † Digging Depth	mm	114
	in	4.5"
12 † Overall Length	mm	9793
	ft/in	32'2"
B † Overall Height with Bucket at Maximum Lift	mm	6016
	ft/in	19'9"
Loader Clearance Circle Radius with Bucket at Carry Position	mm	7635
	ft/in	25'1"
Static Tipping Load, Straight (With tire deflection)	kg	20 885
	lb	46,031
Static Tipping Load, Straight (No tire deflection)	kg	22 305
	lb	49,161
Static Tipping Load, Articulated (With tire deflection)	kg	17 710
	lb	39,033
Static Tipping Load, Articulated (No tire deflection)	kg	18 982
	lb	41,836
Breakout Force (§)	kN	257
	lbf	57,919
Operating Weight*	kg	33 895
	lb	74,704

* Static tipping loads and operating weights shown are based on a machine configuration with Bridgestone 29.5R25 VSNT L4 radial tires, full fluids, operator, axle oil cooler, standard counterweight, steel mill linkage, flat window, rear egress fenders, ride control, steel roof cap, standard starting, steel mill package, turbine engine precleaner, Product Link, open/open differentials, power train guard, standard steering, and sound suppression.

† Illustration shown with Dimension charts.

(§) Measured 100 mm (4") behind tip of cutting edge with bucket hinge pin as pivot point in accordance with ISO 14397-2:2007.

(With tire deflection) Full compliance to ISO 14397-1:2007 Sections 1 thru 6, which requires 2% verification between calculations and testing.

(No tire deflection) Compliance to ISO 14397-1:2007 Sections 1 thru 5.

Other buckets are available and offerings vary by region. Consult your local Cat dealer for further details.



980

Block Handler

The Cat 980 Block Handler is designed to withstand the demanding and harsh environment of block handling applications. The Block Handler's features work together to provide a durable and reliable machine to meet your needs.

Proven Reliability

- Cat C13 engine offers increased power density with a combination of proven electronic fuel and air systems.
- Thorough component design and machine validation processes result in unmatched reliability and uptime.

Durability

- Heavy-duty rims have a thicker center disc and rim section that were specifically designed to carry the additional loads that are common in a block handling application.
- Extreme service transmission with lock-up clutch torque convertor for improved performance and durability.

Superior Fuel Efficiency & Productivity

- Block handler package includes larger tilt cylinders and counterweight for increased load control.
- Rack limiting feature to prevent unintended lever contact with the blocks.
- Block handler counterweight with integrated guard offers higher payload capability for block handling.
- Powershift transmission with lock-up clutch increases fuel efficiency while delivering optimal performance.
- Single clutch and lock-to-lock shifting for faster acceleration and speed on grades.
- Automatic idle engine shutdown system significantly reduces idle time, overall operating hours, and fuel consumption.
- Optional limited slip differentials increase traction and reduce tire slip, lowering operating costs.
- Deeply integrated engine, power train, and hydraulic systems deliver unmatched productivity and fuel efficiency.

Safety Features

- Rearview camera enhances visibility behind the machine, helping you work safely and confidently.
- Optional multiview (360°) vision system helps the operator monitor the surroundings of the machine at all times.
- Optional Cat Detect radar technology enhances awareness by monitoring the working environment and alerts operators to hazards.
- Cab access with wide door, optional remote door opening, and stair-like steps add solid stability.
- Floor-to-ceiling windshield, large mirrors with integrated spot mirrors, and rearview camera provide industry leading all-around visibility.
- Optional access light and under-hood service light system to provide illuminated access to the machine and daily checks even in the dark.

Reduced Maintenance Time and Costs

- Extended fluid and filter change intervals reduce maintenance costs by up to 20%.
- Remote Troubleshoot can connect the machine to the dealer service department to help diagnose problems quickly so you can get back to work.
- Remote Flash works around your schedule to ensure your machine's software is up to date for optimal performance.
- The Cat App helps you manage fleet location, hours, and maintenance schedules; it also alerts you for required maintenance and allows you to request service from your local Cat dealer.
- One-piece tilting hood makes engine compartment access fast and easy.

Work in Comfort in the All New Cab

- Next-generation, easily adjustable seat and suspension for improved operator comfort. It comes in three trim levels and can be equipped with a 4-point harness.
- New in-cab dashboard and high-resolution touch display(s) are easy to use, intuitive, and user friendly.
- Sound suppression, seals, and viscous cab mounts decrease noise and vibration for a quieter work environment.
- The seat-mounted electro-hydraulic joystick steering system provides precision control and dramatically reduces arm fatigue, resulting in excellent comfort and accuracy. An HMU steering wheel is also available.

980 Block Handler Specifications

980 Block Handler Features

1. Larger tilt cylinders for increased load control
2. Extreme service transmission with lock-up clutch torque convertor for improved performance and durability
3. Rack limiting feature to prevent unintended lever contact with the blocks
4. Heavy-duty rims have a thicker center disc and rim section that were specifically designed to carry the additional loads that are common in a block handling application

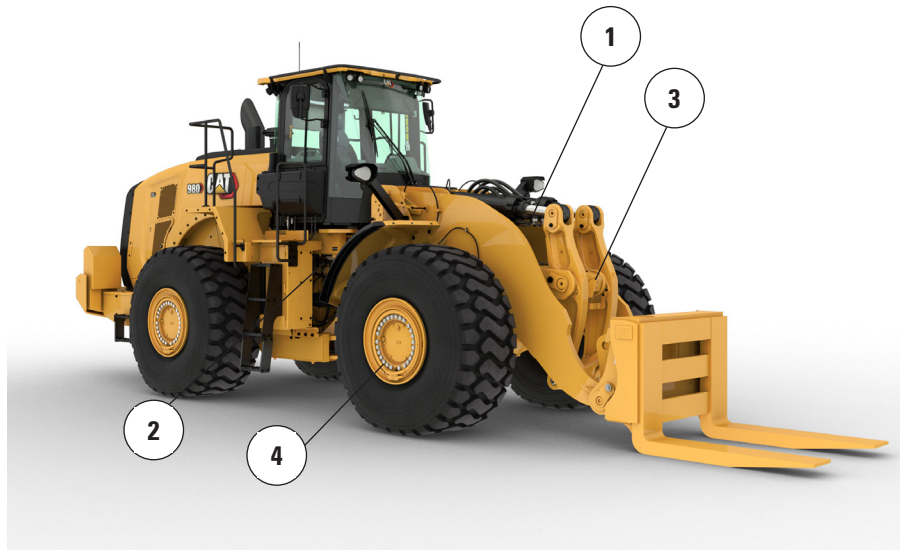

5. Heavier counterweight provides for greater tipping loads while the integrated counterweight guard protects the counterweight from impact
6. Rear frame is reinforced and features solid steel frame rails rearward of the axle
7. Optional axle oil cooler provides lower axle oil temperatures in high braking applications

980 Block Handler Specifications

Tire Options

Tire Brand	BRIDGESTONE	GOODYEAR	BRIDGESTONE
Tire Size	29.5R25	29.5R25	29.5R25
Tread Type	L-3	L3	L-5
Tread Pattern	VJT	RT-3B	VSDL
Casing Strength	**	**	**
Width over Tires – Maximum (empty)*	3263 mm 10'9"	3270 mm 10'9"	3250 mm 10'8"
Width over Tires – Maximum (loaded)*	3289 mm 10'10"	3311 mm 10'11"	3275 mm 10'9"
Change in Vertical Dimensions (average of front and rear)		-1 mm 0"	43 mm 1.7"
Change in Horizontal Reach		4 mm 0.1"	-30 mm -1.2"
Change in Clearance Circle to Outside of Tires		22 mm 0.9"	-14 mm -0.6"
Change in Clearance Circle to Inside of Tires		-22 mm -0.9"	14 mm 0.6"
Change in Operating Weight (without Ballast)		348 kg 767 lb	1392 kg 3,069 lb
Change in Static Tipping Load – Straight		265 kg 584 lb	1059 kg 2,334 lb
Change in Static Tipping Load – Articulated		230 kg 508 lb	922 kg 2,032 lb
Rear Axle Oscillation Angle	±8 degrees	±8 degrees	±8 degrees
Maximum Single-wheel Rise and Fall	340 mm 1'1"	340 mm 1'1"	340 mm 1'1"

*Width over tire bulge and includes tire growth.

980 Block Handler Specifications

Fork Specifications

Fork Specifications

1	Tine Length	mm	1495
		in	58.9
2	Load Center	mm	748
		in	29.4
	Static Tipping Load - Straight (Forks Level)	kg	21931
		lbs	48335
	Static Tipping Load - Articulated (Forks Level)	kg	19180
		lbs	42273
	Rated Load (SAE J1197 - 50% FTSTL)	kg	9590
		lbs	21137
	Rated Load (CEN EN 474-3 Rough Terrain - 60% FTSTL)	kg	11508
		lbs	25364
	Rated Load (CEN EN 474-3 Firm and Level Ground - 80% FTSTL)	kg	15344
		lbs	33819
3	Maximum Overall Length	mm	10365
		in	408.1
4	Reach with Forks at Ground Level	mm	1259
		in	49.6
5	*Ground to Bottom of Tine at Minimum Height and Fork Level	mm	-254
		in	-10.0
6	Reach with Arms Horizontal and Forks Level	mm	1766
		in	69.5
7	Reach with Fork at Maximum Height	mm	839
		in	33.0
8	Ground to Top of Tine with Arms Horizontal and Fork Level	mm	1971
		in	77.6
9	Ground to Top of Tine at Maximum Height and Fork Level	mm	4239
		in	166.9
10	Overall Height of Fork at Full Lift (top of carriage to ground)	mm	5284
		in	208.0
11	Clearance at Full Lift and Max Dump	mm	2842
		in	111.9
12	Max Discharge Angle from Horizontal	deg	47
13	Overall Carriage Width	mm	1504
		in	59.2
14	Overall Carriage Height	mm	1160
		in	45.7
15	Outside Tine Width (max spread)	mm	1454
		in	57.2
16	Outside Tine Width (min spread)	mm	1454
		in	57.2
	Tine Width (single tine)	mm	300.0
		in	11.8
	Tine Thickness	mm	115.0
		in	4.5
	Tine Capacity	kg	26488
		lbs	58380
	Operating Weight	kg	33601
		lbs	74056

*Negative values indicate below grade

980 BH

Block Handler Fork

59" Tine

453-9870

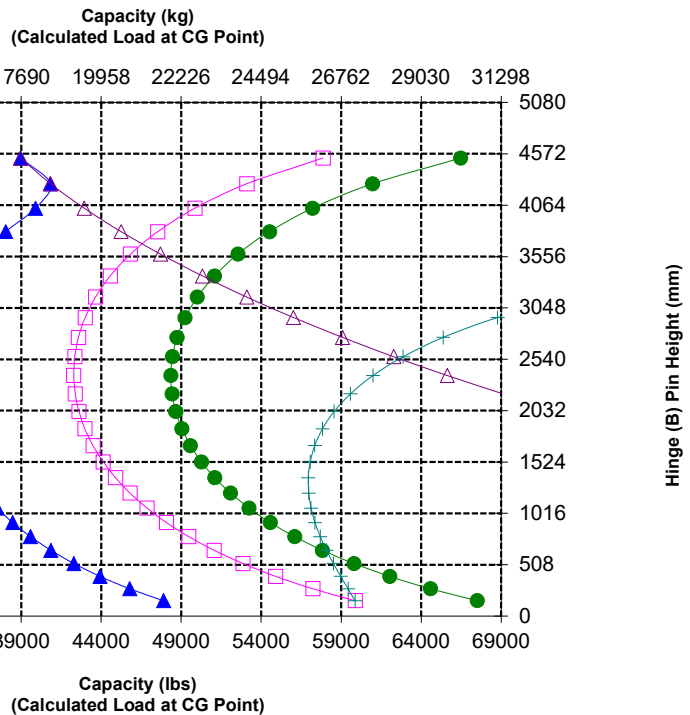
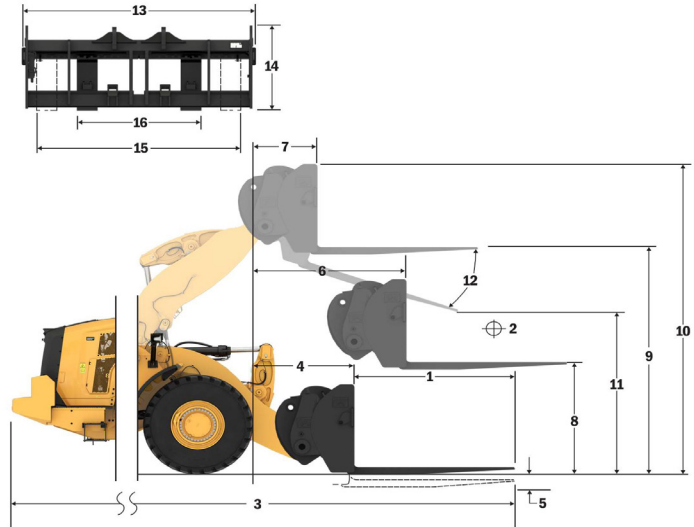

NOTE: Static tipping loads and operating weight are based on the following loader configuration: Bridgestone ** VJT L3 Tires, Air Conditioning, Ride Control, Powertrain Guard, Full Fluids, Fuel Tank, Coolant, Lubricants, and Operator.

Specifications and ratings conform to the following standards: SAE* J1197, ISO 14397-1, CEN** EN 474-3.

The rated operating load for a loader equipped with a pallet fork is determined by:
SAE J1197: 50% of full turn static tipping load or hydraulic limit.
CEN EN 474-3: 60% of full turn static tipping load on rough terrain or hydraulic limit.
CEN EN 474-3: 80% of full turn static tipping load on firm and level ground or hydraulic limit.

*SAE - Society of Automotive Engineers
**CEN - European Committee for Standardization



WARNING: Do not exceed tine load capacity. Individual tine capacity is stamped on the side of each tine.



オフロード法2014年
基準適合

For more complete information on Cat products, dealer services, and industry solutions, visit us on the web at www.cat.com.

Materials and specifications are subject to change without notice. Featured machines in photos may include additional equipment. See your Cat dealer for available options.

© 2024 Caterpillar. All Rights Reserved. CAT, CATERPILLAR, LET'S DO THE WORK, their respective logos, Product Link, Fusion, XT, "Caterpillar Corporate Yellow", the "Power Edge" and Cat "Modern Hex" trade dress as well as corporate and product identity used herein, are trademarks of Caterpillar and may not be used without permission.

AEXQ3862-00 (5-2024)
Build Number: 14B
(N Am, Europe, Japan,
China, India, Korea, Turkey,
Chile, Colombia)

