



Cat[®] 924

WHEEL LOADER

FEATURES:

CONFIGURED FOR SUCCESS

- Cat wheel loaders set the standard for productivity, fuel efficiency, operator comfort and low operating costs. The Cat 924 Small Wheel Loader features a high torque C7.1 engine that works in conjunction with an intelligent hydrostatic power train to deliver exceptional fuel efficiency. Meets Brazil MAR-1 emission standards, equivalent to U.S. EPA Tier 3 and EU Stage IIIA.

ENJOY ALL DAY COMFORT

- Have a seat in the new Cat small wheel loader and enjoy automatic temperature control, class leading sound levels, enhanced all-around visibility and low-effort joystick controls that move with you on a fully adjustable seat suspension. A large spacious operator environment combined with Caterpillar hydraulic cylinder damping and smooth predictable controls make this the most comfortable seat on your jobsite.
- An upgrade to multi-view camera and rear object detection gives you an extra eye on the jobsite while the new optional force feedback joystick steering keeps you feeling confident on those long shifts. The operator not present function helps to isolate the machine if you leave the environment; while seat belt notifications give you a gentle reminder to buckle up.

EFFICIENTLY POWERFUL

- Experience the difference with an intelligent hydrostatic power train and industry leading fuel savings through a lower maximum engine speed working in combination with a new auto engine RPM mode. This provides efficiency as standard with a boost in power when you need it. Optimize traction and minimize wheel slip with a new Auto Wheel Torque system tuned to provide peak performance while maximizing tire life and keeping operating costs low. Track your production and accurately hit your load targets with Cat Payload.

WORK MADE EASY

- Move more with the Caterpillar patented quick loading performance series buckets and optimized Z-bar linkage with enhanced forward visibility that combines the digging efficiency of a traditional Z-bar with tool carrier capabilities. The parallel lift and high tilt forces throughout the working range allow you to confidently handle loads with precise control.
- Multi-function work has never been easier with dedicated pumps for each system and a flow sharing implement valve governed by an intelligent power management system. Simultaneously lift, steer, and drive without compromise. Upgrade to autolube and tire pressure monitoring to make service easy and get to work quicker. Light the way with auto roading lights that come on at night fall.

CUSTOMIZE YOUR EXPERIENCE

- Meet your application requirements and individual preferences with Caterpillar industry first Hystat™ Operator Modes featuring four unique power train settings. Select classic torque converter for smooth rollout, conventional hystat for aggressive engine braking, an ice mode that maximizes your control on slippery underfoot, and an all new single pedal mode for simplified use.
- Fine tune machine performance with adjustments at your fingertips through programmable joysticks, soft touch buttons, and a new jog dial that works in combination with a standard touch screen display. Quickly recall attachment profiles that maintain key settings for versatility on the jobsite and optimal efficiency.

UPGRADES AND SERVICES

- Enjoy a full range of upgrades and accessories to configure your small wheel loader for a broader range of applications.
- Utilize readily available services and maintenance parts, including a range of self-service options (SSO) and dealer installed kits.



924 Wheel Loader

Purpose Built

A complete range of optional equipment and work tool attachments gives you the versatility to configure a handler package to be successful in your business. Get with Caterpillar to configure yours.



- Increased Payload:** Additional counterweight improves stability without reducing ground clearance or departure angle to maximize performance.
- Long Life Sand and Gravel Buckets:** Performance series buckets deliver higher fill factors and better material retention for significant productivity and fuel efficiency improvements. Buckets feature a long floor, open throat, curved side bars and additional serviceable wear plates including corner guards.
- Protect your Power Train:** Increase your fording depth with optional elevated breathers. Remote mounted high on the machine for the front and rear axles and hydrostatic gear box. Allows settling pond cleanout without contamination.
- Guard Your Investment:** Choose from a complete range of optional guarding to protect your machine from the harsh environment of a waste handling application. Machine guarding is purpose built to protect the machine's major components.
- Breathe Clean:** Maximize your engine life and extend filter cleaning intervals with a turbine pre-cleaner. Keep cool with a reversing fan to purge the single plane, widely spaced core cooling package and brush-less sealed alternator. Breathe clean with a powered pre-cleaner for the operator environment.
- Maximize Tire Life:** Fine tune your wheel torque to match the underfoot conditions and maximize performance while extending tire life. Standard auto wheel torque is ideal for waste handling applications.

Specifications

Engine

Engine Model	Cat® C7.1*	
Performance Mode	Automatic	
Rated Gross Power		
Rated Engine Speed	1,800 rpm	
ISO 14396	105 kW	141 hp
ISO 14396 (DIN)	143 mhp (PS)	
Rated Net Power		
SAE J1349 at Minimum Fan Speed	102 kW	137 hp
ISO 9249 at Minimum Fan Speed	102 kW	137 hp
ISO 9249 (DIN) at Minimum Fan Speed	140 mhp (PS)	

*Meets Brazil MAR-1 emission standards, equivalent to U.S. EPA Tier 3 and EU Stage IIIA.

• Advertised power is tested per the specified standard in effect at the time of manufacture.

Engine (continued)

Maximum Gross Torque		
Engine Speed	1,400 rpm	
ISO 14396	725 N-m	534 lbf-ft
Maximum Net Torque		
SAE J1349	704 N-m	519 lbf-ft
ISO 9249	711 N-m	524 lbf-ft
Displacement	427 in ³	7.01 L
Bore	4 in	105 mm
Stroke	5 in	135 mm

• Net power ratings are tested at the reference conditions for the specified standard and denote power available at the flywheel when engine is equipped with alternator, air cleaner, emission components and fan at specified speed.

Specifications (continued)

Buckets

Bucket Capacities	1.9-5.0 m ³	2.5-6.5 yd ³
-------------------	------------------------	-------------------------

Steering

Steering Cylinder		
Bore Diameter	70 mm	2.8 in
Rod Diameter	40 mm	1.6 in
Stroke	438 mm	17.2 in
Maximum Flow – Steering Pump	125 L/min	33 gal/min
Maximum Working Pressure – Steering Pump	24 130 kPa	3,500 psi
Steering Cycle Times (Full Left to Full Right)		
Minimum RPM: Pump Flow Limited	2.8 seconds	
Maximum RPM: 90 rpm Steering Wheel Speed	2.4 seconds	

Loader Hydraulic System

Maximum Flow – Implement Pump	150 L/min	40 gal/min
3rd Function Maximum Flow*	150 L/min	40 gal/min
4th Function Maximum Flow*	150 L/min	40 gal/min
Maximum Working Pressure – Implement Pump	26 000 kPa	3,771 psi
Relief Pressure – Tilt Cylinder	28 000 kPa	4,061 psi
3rd and 4th Function Maximum Working Pressure	26 000 kPa	3,771 psi
3rd and 4th Function Relief Pressure	28 000 kPa	4,061 psi
Lift Cylinder – Standard Lift Linkage:		
Bore Diameter	110 mm	4.3 in
Rod Diameter	60 mm	2.4 in
Stroke	728 mm	28.7 in
Tilt Cylinder – Standard Lift Linkage:		
Bore Diameter	130 mm	5.1 in
Rod Diameter	70 mm	2.8 in
Stroke	555 mm	21.9 in
Hydraulic Cycle Time:		
Raise (Ground Level to Maximum Lift)	5.4 seconds	
Dump (at Maximum Lift Height)	1.5 seconds	
Float Down (Maximum Lift to Ground Level)	2.6 seconds	
Total Cycle Time	9.5 seconds	

*3rd and 4th function flow is fully adjustable from 20% to 100% of maximum flow through the secondary display when equipped.

Service Refill Capacities

Fuel Tank	195 L	51.5 gal
Cooling System	32 L	8.5 gal
Engine Crankcase	19.5 L	5.2 gal
Transmission (gearbox)	8.5 L	2.2 gal
Axles:		
Front	21 L	5.5 gal
Rear	21 L	5.5 gal
Hydraulic System (including tank)	160 L	42.3 gal
Hydraulic Tank	90 L	23.8 gal

Transmission

Forward and Reverse		
Range 1*	1-13 km/h	0.6-8 mph
Range 2	13 km/h	8 mph
Range 3	27 km/h	17 mph
Range 4	40 km/h	25 mph

*Creeper control allows maximum speed range adjustability from 1 km/h (0.6 mph) to 13 km/h (8 mph) in Range 1 through the secondary display when equipped. Factory default is 7 km/h (4.4 mph).

Tires

Standard Size:	20.5 R25, radial (L-3)
Other Choices Include:	17.5 R25, radial (L-3)
	17.5-25 16 PR (L-3)
	20.5-25 16 PR (L-3)

- Other tire choices are available. Contact your Cat dealer for details.
- In certain applications, the loader's productive capabilities may exceed the tire's tonnes-km/h (ton-mph) capabilities.
- Caterpillar recommends that you consult a tire supplier to evaluate all conditions before selecting a tire model.

Cab

Rollover Protective Structure (ROPS):	ISO 3471:2008
Falling Object Protective Structure (FOPS):	ISO 3449:2005 LEVEL II

Axles

Front	Fixed
	Open differential (standard)
	Locking differential (optional)
Rear	Oscillating ±11 degrees
	Open differential (standard)
	Limited slip differential (optional)

924 Wheel Loader

CONFIGURED FOR SUCCESS:

Machine upgrades, either as a do-it-yourself option or dealer installed.

Guards

- Windshield
- Tilt cylinder
- Lights
- Fender deflectors
- Drive shaft
- Hitch
- Steering cylinders
- Side power train
- Lower power train
- Crank case

Debris Management

- Reversing fan
- Sealed alternator
- Turbine engine precleaner
- Powered cab precleaner

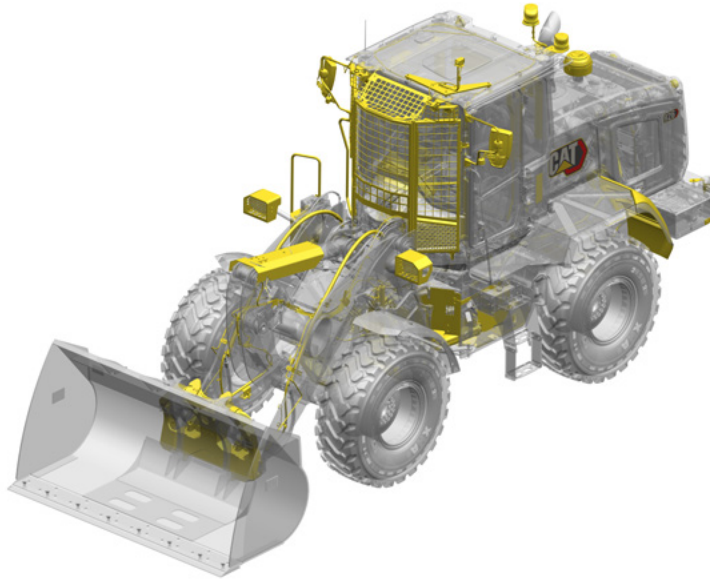

Operator Environment

- Bluetooth Key Fob
- Multi View Camera
- Internal Mirrors

Other Options

- Autolube
- Coupler: Fusion
- Auxiliary hydraulics: 3rd and 4th
- Ride control
- Fenders: extended and full coverage
- Counterweights
- Rear object detection
- Beacon: Warning and Seatbelt
- LED auxiliary lights
- Cat Payload Printer
- Tire Pressure Monitoring
- Polycarbonate windshield
- 4-point harness

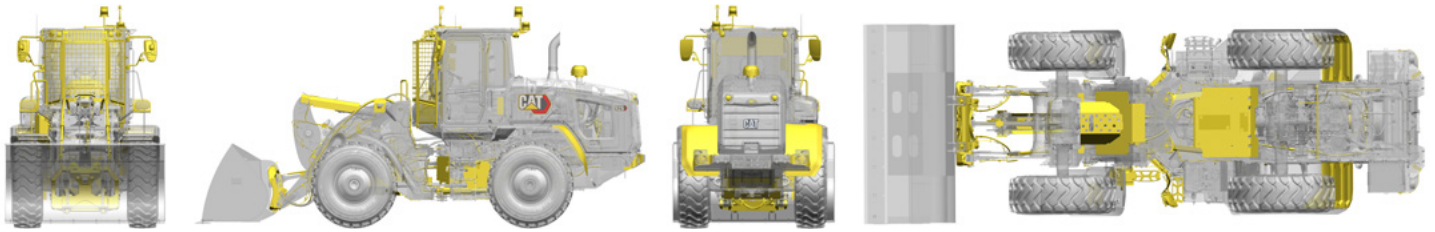

WORK TOOL ATTACHMENTS FOR EVERY JOB:

Get more from your machine with Cat attachments. Choose from a wide variety of options and tailor your machine to different tasks and conditions.



General Purpose Buckets



Light Material Buckets



High Dump Buckets



Pallet Forks



Construction Forks



Angle and Pickup Brooms



Snow Pushes



Snow Plows



Millyard Forks



Material Handling Arms

Dimensions and Operating Specifications (All dimensions are approximate. Dimensions vary with bucket and tire choice.)

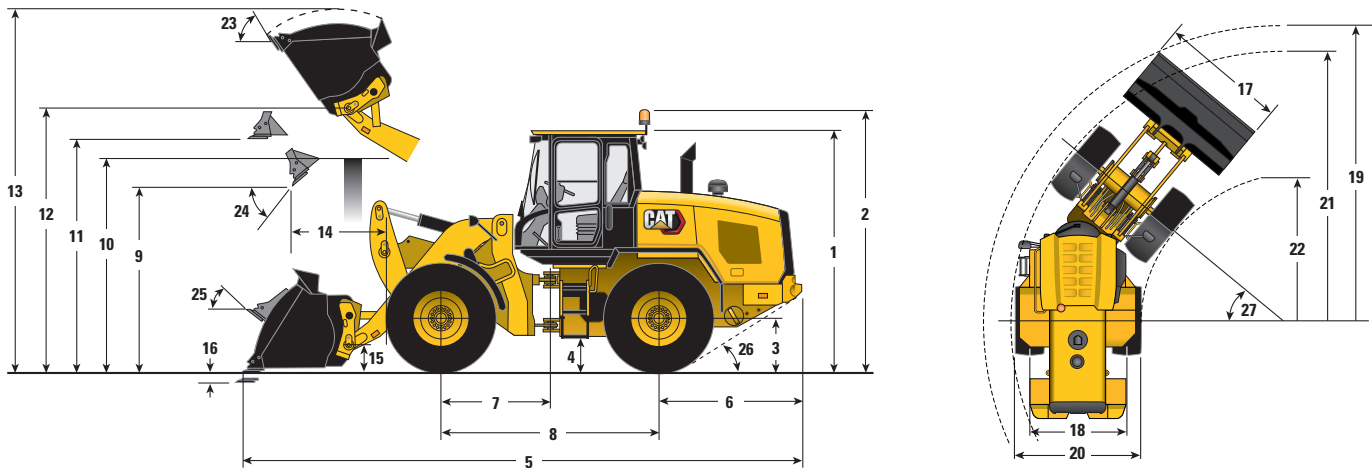

Counterweight Configuration	924 – 20.5 Tires		924 – 17.5 Tires	
	Standard	Standard	Standard	Standard
** 1 Height: Ground to Cab	3340 mm	10'11"	3252 mm	10'8"
** 2 Height: Ground to Beacon	3707 mm	12'2"	3619 mm	11'10"
** 3 Height: Ground to Axle Center	685 mm	2'3"	597 mm	2'0"
** 4 Height: Ground Clearance	397 mm	1'4"	309 mm	1'0"
* 5 Length: Overall	7418 mm	24'4"	7486 mm	24'7"
6 Length: Rear Axle to Bumper	1958 mm	6'5"	1958 mm	6'5"
7 Length: Hitch to Front Axle	1500 mm	4'11"	1500 mm	4'11"
8 Length: Wheelbase	3000 mm	9'10"	3000 mm	9'10"
* 9 Clearance: Bucket at 45°	2801 mm	9'2"	2713 mm	8'11"
** 10 Clearance: Load over Height	3308 mm	10'10"	3220 mm	10'7"
** 11 Clearance: Level Bucket	3526 mm	11'7"	3437 mm	11'3"
** 12 Height: Bucket Pin	3853 mm	12'8"	3765 mm	12'4"
** 13 Height: Overall	5068 mm	16'8"	4980 mm	16'4"
* 14 Reach: Bucket at 45°	990 mm	3'3"	1057 mm	3'6"
15 Carry Height: Bucket Pin	402 mm	1'4"	408 mm	1'4"
** 16 Dig Depth	100 mm	3.9"	188 mm	7.4"
17 Width: Bucket	2550 mm	8'4"	2550 mm	8'4"
18 Width: Tread Center	1933 mm	6'4"	1943 mm	6'4"
19 Turning Radius: Over Bucket	5916 mm	19'5"	5933 mm	19'6"
20 Width: Over Tires	2543 mm	8'4"	2456 mm	8'1"
21 Turning Radius: Outside of Tires	5404 mm	17'9"	5360 mm	17'7"
22 Turning Radius: Inside of Tires	2850 mm	9'4"	2893 mm	9'6"
23 Rack Angle at Full Lift		53°		53°
24 Dump Angle at Full Lift		49°		49°
25 Rack Angle at Carry		42°		44°
26 Departure Angle		33°		33°
27 Articulation Angle		40°		40°
* Tipping Load – Straight (ISO 14397-1:2007)	8652 kg	19,075 lb	8404 kg	18,527 lb
* Tipping Load – Full Turn (ISO 14397-1:2007)	7499 kg	16,533 lb	7282 kg	16,054 lb
* Breakout	9646 kg	21,266 lb	9691 kg	21,365 lb
* Operating Weight	11 775 kg	25,960 lb	11 417 kg	25,170 lb

*Vary with bucket.

**Vary with tire.

Dimensions listed are for a machine configured with specified tires and counterweight, 80 kg (176 lb) operator, and powertrain guard. Values listed are for a 2.1 m³ (2.7 yd³) pin on, general purpose performance series bucket with bolt-on cutting edge.

924 Environmental Declaration

The following information applies to the machine at the time of final manufacture as configured for sale in the regions covered in this document. The content of this declaration is valid as of the date issued; however, content related to machine features and specifications are subject to change without notice. For additional information, please see the machine's Operation and Maintenance Manual.

For more information on sustainability in action and our progress, please visit <https://www.caterpillar.com/en/company/sustainability>.

Engine

- The Cat® C7.1 engine meets Brazil MAR-1 emission standards, equivalent to U.S. EPA Tier 3 and EU Stage IIIA.
 - Cat engines are compatible with diesel fuel blended with the following lower-carbon intensity fuels** up to:
 - ✓ 100% biodiesel FAME (fatty acid methyl ester)*
 - ✓ 100% renewable diesel, HVO (hydrogenated vegetable oil) and GTL (gas-to-liquid) fuels
- Refer to guidelines for successful application. Please consult your Cat dealer or "Caterpillar Machine Fluids Recommendations" (SEBU6250) for details.
- *For use of blends higher than 20% biodiesel, consult your Cat dealer.*
- **Tailpipe greenhouse gas emissions from lower-carbon intensity fuels are essentially the same as traditional fuels.*

Air Conditioning System

- The air conditioning system on this machine contains the fluorinated greenhouse gas refrigerant R134a (Global Warming Potential = 1430). The system contains 1.9 kg (4.2 lb) of refrigerant which has a CO₂ equivalent of 2.717 metric tonnes (2.99 tons).

Paint

- Based on best available knowledge, the maximum allowable concentration, measured in parts per million (PPM), of the following heavy metals in paint are:
 - Barium < 0.01%
 - Cadmium < 0.01%
 - Chromium < 0.01%
 - Lead < 0.01%

Sound Performance

With cooling fan speed at 70% of maximum value:

Operator Sound Pressure Level (ISO 6396:2008) – 68 dB(A)*

Exterior Sound Power Level (ISO 6395:2008) – 101 dB(A)**

*Measurements were conducted with properly installed and maintained cab doors and windows closed.

Oils and Fluids

- Caterpillar factory fills with ethylene glycol coolants. Cat Diesel Engine Antifreeze/Coolant (DEAC) and Cat Extended Life Coolant (ELC) can be recycled. Consult your Cat dealer for more information.
- Cat Bio HYDO™ Advanced is an EU Ecolabel approved biodegradable hydraulic oil.
- Additional fluids are likely to be present, please consult the Operations and Maintenance Manual or the Application and Installation guide for complete fluid recommendations and maintenance intervals.

Features and Technology

- The following features and technology may contribute to fuel savings and/or carbon reduction. Features may vary. Consult your Cat dealer for details.
 - Cat Production Measurement
 - Auto Wheel Torque Control
 - Auto Engine RPM
 - Intelligent Hystat Transmission
 - Performance Series Buckets
 - Engine Idle Shutdown
 - Variable Displacement Pumps

Recycling

- The materials included in machines are categorized as below with approximate weight percentage. Because of variations of product configurations, the following values in the table may vary.

Material Type	Weight Percentage
Steel	67.08%
Iron	12.92%
Rubber	6.63%
Nonferrous Metal	3.42%
Other	3.10%
Fluid	2.13%
Plastic	1.51%
Uncategorized	1.39%
Mixed Metal	1.01%
Mixed-Metal and Nonmetal	0.79%
Mixed Nonmetallic	0.01%
Total	100.00%

- A machine with higher recyclability rate will ensure more efficient usage of valuable natural resources and enhance End-of-Life value of the product. According to ISO 16714:2008 (Earthmoving machinery – Recyclability and recoverability – Terminology and calculation method), recyclability rate is defined as percentage by mass (mass fraction in percent) of the new machine potentially able to be recycled, reused or both.

All parts in the bill of material are first evaluated by component type based on a list of components defined by the ISO 16714:2008 and Japan CEMA (Construction Equipment Manufacturers Association) standards. Remaining parts are further evaluated for recyclability based on material type.

Because of variations of product configurations, the following value in the table may vary.

Recyclability – 95%

STANDARD EQUIPMENT

OPERATOR ENVIRONMENT

- 75 mm (3 in) retractable seatbelt
- Automatic temperature control
- Cab, enclosed ROPS/FOPS pressurized and sound suppressed
- Push to Start
- 8 Inch Touch Screen
- Programmable Joystick
- Cup holders
- External mirrors with lower parabolic
- Ground level cab door release
- Hydraulic control lockout
- Interior cab lighting, door
- Lunch box storage
- Radio ready speakers
- Seat mounted electronic implement controls, adjustable
- Sliding glass on side window
- Column mounted multi function control lights, wipers, turn signal
- Suspension seat, fabric
- Tilt steering wheel
- Tinted front glass
- Wet arm wiper/washer, 2-speed and intermittent, front
- Wet arm wiper washer, rear
- Mounting Provision
- Digital hour meter, odometer and tachometer
- Digital ground speedometer and direction indicator
- Engine coolant temperature gauge
- Fuel and diesel exhaust fluid levels
- Hydraulic oil temperature gauge

POWER TRAIN

- Cat C7.1 engine
- Auto idle shut down feature
- Auto Engine RPM
- Meets Brazil MAR-1 emission standards, equivalent to U.S. EPA Tier 3 and EU Stage IIIA.
- Turbocharged and aftercooled
- Filtered crankcase breather
- Power Modes (standard and performance)
- Dry type air cleaner
- Coolant protection to -34 °C (-29 °F)
- Fuel priming pump, automatic
- Fuel water separator
- Differential lock in front axle
- Axle seal guards
- Enclosed wet disc full hydraulic brakes
- Parking brake, electric
- Lubed for life driveshafts
- Hydrostatic transmission with electronic control
- Operator modes (TC, Hystat, Single Pedal and Ice)
- Directional shift aggressiveness (fast, medium, slow)
- Auto Wheel Torque control, adjust wheel torque
- Creeper control, adjust ground speed
- Single plane cooling package, wide 6 fins per inch density
- Hydraulically driven demand cooling fan
- Scheduled Oil Sampling (S-O-SSM) port, engine, coolant, transmission

HYDRAULICS

- Automatic lift and bucket kickouts, adjustable in-cab
- Bucket and fork modes, adjustable in-cab
- Cylinder damping at kickout and mechanical end stops
- Fine mode control (fast, medium, slow)
- Hydraulic response setting (fast, medium, slow)
- Hydraulic diagnostic connectors and S-O-S ports
- Hydraulic sight gauge, visible
- Load sensing hydraulics and steering
- Seat mounted hydraulic joystick controls

ELECTRICAL

- Alternator, 115-amp, heavy duty
- 12V power supply in cab (2)
- Batteries, 1,000 CCA (2) 24-volt system, disconnect switch
- Back up alarm
- Emergency shutdown switch
- LED rear stop and turn lights
- Heavy duty gear reduction starter
- Product Link™
- Remote jump start post
- Resettable main and critical function breakers
- Roading lights front and rear

OTHER

- Large-access enclosure doors with adjustable close/open force
- Parallel lift loader linkage
- Recovery hitch with pin
- Remote mounted lubrication points
- Lockable compartments

924 Wheel Loader

OPTIONAL EQUIPMENT

OPERATOR ENVIRONMENT

- Joystick steering – 25 mph (40 kph) capable
- Radio packages
- Telescoping Steering Column
- Deluxe seat – fully adjustable fabric air suspension seat with mid seat backrest
- Premium seat – fully adjustable leather and fabric air suspension with high backrest and air lumbar support. Seat is heated and ventilated on bottom cushion and backrest.
- Rear Object Detection
- Multi View Camera
- Front View Camera, roof mounted
- Heated external Mirrors (2)
- Electrically adjustable and heated external mirrors (2)
- Internal Mirrors (2)
- Sunscreen, front and rear
- Operator Not Present system
- Powered precleaned for cab air
- Cab guarding

POWER TRAIN

- Differential, limited slip, rear
- Differential lock in front axle
- Powertrain Guarding
- Range of Tire Options
- Fenders (extended cover and full coverage)

HYDRAULICS

- Auxiliary flow, third and fourth function
- Connect Under Pressure Disconnects
- Ride Control System, adjustable via display
- Autolube, integrated in display
- Biodegradable Oil
- Debris packages (low, medium, high)

ELECTRICAL

- Cold start package
- Ether starting aid, block heater and additional batteries, 1,000 CCA (4 total)
- Lights, auxiliary, halogen or LED with engine compartment lights
- Beacon light, strobe
- Light Guarding

OTHER OPTIONAL EQUIPMENT

- Coupler (Fusion)
- Heavy Counterweight
- Cat Payload Printer
- Cylinder Guarding
- Range of Work Tool Attachments

NOTE: Not all features are available in all regions.



For more complete information on Cat products, dealer services, and industry solutions, visit us on the web at www.cat.com

© 2024 Caterpillar
All rights reserved

Materials and specifications are subject to change without notice. Featured machines in photos may include additional equipment. See your Cat dealer for available options.

CAT, CATERPILLAR, LET'S DO THE WORK, their respective logos, "Caterpillar Corporate Yellow," the "Power Edge" and Cat "Modern Hex" trade dress as well as corporate and product identity used herein, are trademarks of Caterpillar and may not be used without permission.

AEHQ8460 (01-2024)
Build Number: 14A
(AME, AUZ, CIS, LACD,
Southeast Asia)

