

Example of screen layout

XLM SWITCHGEAR

Emergency Transfer and Load Management (XLM) paralleling switchgear is designed for applications that require control of multiple engine generator sets and utility sources. XLM (208-38kV) switchgear allows for the provision of power through single or multiple distribution breakers..

XLM standard controls overlay onto switchgear with configurable power flow including options for feeding the load through main lugs or electrically operated distribution circuit breakers.

STANDARD FEATURES

Choice of Operator Interface Touchscreen:

- 19" Surface Acoustic Wave Color TFT
- 15" Resistive Color TFT
 - Intuitive Operation through Informative Overview and Detail Screens
 - Control and Monitoring of System Parameters
 - Control and Monitoring of Genset and Utility Parameters
 - Password Protection for Critical Settings
 - Alarm Logging and Annunciation
- Circuit Breaker Control Switch with indicators
- Audible Alarm & Horn Silence Button
- Emergency Stop Button for Each generator
- "Instant Auto" Switch to Return System to Ready State
- Standard 2 Year Warranty

AVAILABLE OPTIONS

- Redundant Touchscreens
- Redundant Communication Networks
- ATS and UPS Communication & Display
- Data Table Interface for Remote Monitoring
- Historical Trending (19" Touchscreen)
- Remote Event Notification
- Extended Warranty & Preventative Maintenance
- Utility Interconnect Multifunction Relay (Utility Grade)

CONTROL FUNCTIONS

- High Speed Supervisory Network
- Automatic Start/Stop
- Automatic "Dead Bus" Coordination
- Automatic Power Factor Control when in Parallel with Utility Power
- Programmable Load Shed / Load Add Functions
- Networked Engine Communications (requires Cat[®] EMCP3.2, 3.3, 4.2, 4.3, 2+)
- Generator & Utility Protection (Industrial Grade)
- Engine Tuning
- Mode Selection
- Selectable Auto/ Manual Control
- Password Protection for Protective Settings and Setup
- Load/No Load Test

MONITORING FUNCTIONS

- NFPA 99/110 Compliant Alarm Annunciation with Audible Horn
- Engine/Generator Parameters & Setpoints
- Voltage, Frequency, Phase Current, Power Factor, kW, kVAR, kWh, kVARh
- Engine Control Mimic Screen with gauges for
 - RPM
 - DC Battery Voltage
 - Oil Pressure
 - Engine Coolant Temperature
 - Engine Hours
 - Number of Starts
- Circuit Breaker Status
- ATS Status (option)
- Alarm Summary and Settings Reports
- Load Charts

Functional Description	
Cat Engine-Generators	208-15kV
Switchgear Voltages and Frequencies	208V-38kV, 50/60Hz
Environmental Parameters	
Humidity	0 to 95% Noncondensing
Operating Temperatures	0° to 50° C
Storage Temperature	-20° C to +60° C
Enclosures	NEMA 1 or NEMA 3R, Freestanding Construction
Standards	
Seismic	IBC, CBC, UBC & OSHPD Certified
Low Voltage	NEMA SG-5
	CSA
	ANSI C37.51
	ANSI C37.20.1
	UL 1558 or UL 891
Medium Voltage	NFPA 110, NFPA 99 and NFPA 70
	NEMA SG-5
	ANSI / IEEE C37.20.2
	CSA-C22.2 No. 31-M89
	EEMAC G8-3.2
	NFPA 70, NFPA 99 and NFPA 1110

Typical XLM Application Example

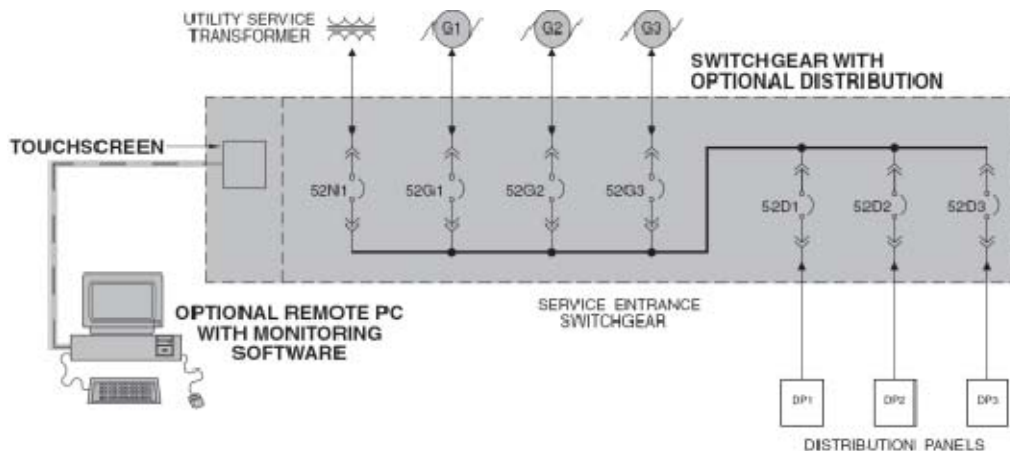

Information contained in this publication may be considered confidential. Discretion is recommended when distributing. Materials and specifications are subject to change without notice.

CAT, CATERPILLAR, LET'S DO THE WORK, their respective logos, "Caterpillar Corporate Yellow," the "Power Edge" and Cat "Modern Hex" trade dress as well as corporate and product identity used herein, are trademarks of Caterpillar and may not be used without permission.