



Shown with optional padfoot shell kit configuration.

# Cat<sup>®</sup> CS16

## Smooth Drum Vibratory Soil Compactor

**The Cat<sup>®</sup> CS16 Vibratory Soil Compactor features a smooth drum and is ideally suited for granular soil applications or cohesive soil applications with the use of an optional padfoot shell kit. A reliable propel system improves performance and efficiency and compaction technology solutions help you reach target density faster.**

### Efficient Power

- Built around a dual pump propel system, two pumps provide separate dedicated flow to the drum drive motor and rear axle motor for exceptional gradeability and traction in forward and reverse.
- Powered by a Cat<sup>®</sup> C4.4 engine that meets U.S. EPA Tier 4 Final emission standards.
- Eco-mode limits engine RPM helping to reduce fuel consumption.
- Engine Idle Shutdown Timer reduces fuel burn and unnecessary idle time by shutting down the machine after a pre-set idling period.
- A variable speed cooling fan operates at the lowest possible speed for optimal cooling.
- Bolt-on leveling blade option increases machine versatility.

### Exceptional Compaction Performance

- High static linear loads and amplitudes.
- Exclusive eccentric weight design provides high reliability, smooth performance and low noise.
- Automatic Speed Control and Auto-vibe functions make it easy to ensure consistent, high-quality compaction.
- The Variable Frequency option provides a wide range of frequencies to help maximize compaction performance.
- Increase machine versatility with the addition of an oval or square padfoot shell kit, allowing your smooth drum machine to compact semi-cohesive and cohesive materials.

### Safe and Comfortable Work Environment

- A rear vision camera with large color touchscreen display enhances visibility for more complete operator control and safety.
- The pivoting seat with integrated multifunction LCD display and control console move with the operator.
- Outstanding visibility to the front and rear of machine.
- Low sound levels and vibration for greater operator comfort and productivity.
- Operators are protected from the elements by a climate-controlled ROPS/FOPS cab with hinged glass windows.

### Enhance Quality and Productivity with Technology

- Get complete process control with increased coverage and more uniform compaction results using the optional exclusive semi-autonomous Command for Compaction technology to automate compaction.
- Optional Cat Compact technologies help you consistently meet compaction targets faster, more uniformly, and in fewer passes – saving on fuel and reducing rework and material costs.
  - Exclusive Machine Drive Power (MDP) is an energy-based measurement and can be used on all soil types.
  - Compaction Meter Value (CMV) is an accelerometer-based measurement for granular soils.

# Cat® CS16 Smooth Drum Vibratory Soil Compactor

## Virtually Maintenance Free

- Maintenance-free hitch with sealed-for-life bearings.
- Ground-level access to the engine compartment and cooling module for easy service and fluid sampling.
- Monitor fluid conditions with regular sampling to help extend change intervals up to 500 hours engine oil, 3000 hours eccentric housing and hydraulic oil, and 12000 hours coolant.
- Extended maintenance intervals not only reduce downtime but decrease the amount of fluid and filters that are replaced over the life of the machine.

- VisionLink® takes the guesswork out of managing your entire fleet—regardless of size or equipment manufacturer\*—by providing maintenance needs, machine hours, location, fuel usage, idle time, diagnostic codes, and more through interactive dashboards on your mobile device or desktop, helping you make informed decisions that lower costs, simplify maintenance, and improve safety and security on your jobsite.

\* Data field availability can vary by equipment manufacturer and is provided through an application programming interface (API).

## Vibratory Soil Compactor Selection Guide

Not all compactors are ideal for every job. This chart helps you select which model is best suited for your work. Not all models listed are available in each region. Contact your Cat dealer representative for more information.

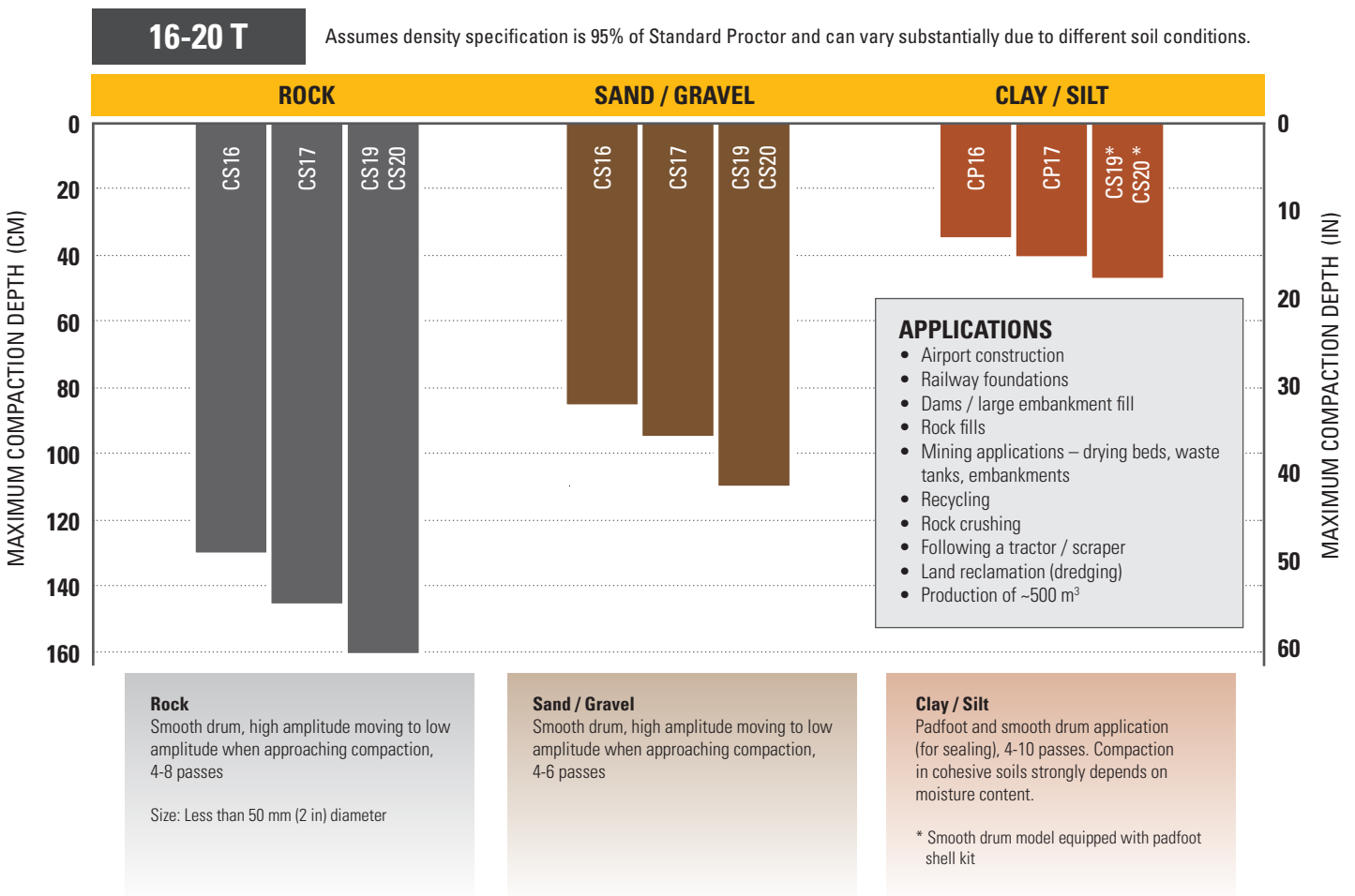

# Cat® CS16 Smooth Drum Vibratory Soil Compactor

## Standard and Optional Equipment

Standard and optional equipment may vary. Consult your Cat dealer for details.

	Standard	Optional		Standard	Optional
<b>OPERATOR ENVIRONMENT</b>			<b>POWERTRAIN</b>		
ROPS/FOPS Cab with Climate Control, Cloth Seat, Exterior Rear View Mirrors	✓		Cat C4.4 Engine	✓	
Sun Visor (Cab)		✓	Air Cleaner, Dual Element	✓	
Roll-Down Screen (Cab)		✓	Three Speed Throttle Switch including Eco-mode	✓	
Adjustable Seat with Integrated Console	✓		Automatic Speed Control (ASC)	✓	
LCD Display with Lockable Vandalism Guard	✓		Dual Propel Pumps; One for Drum Drive, One for Rear Axle	✓	
Adjustable Tilting Steering Column with Integrated Cup Holders	✓		Fuel Filter, Water Separator, Priming Pump, Water Indicator	✓	
Rear Vision Camera System with Color Touchscreen Display	✓		Tilting Radiator / Hydraulic Oil Cooler	✓	
High Visibility 50 mm (2 in) Seat Belt	✓		Dual Braking System	✓	
High Visibility 76 mm (3 in) Seat Belt		✓	Two-Speed Hydrostatic Transmission	✓	
12-volt Power Outlet	✓		Limited Slip Differential	✓	
Horn, Backup Alarm	✓		Transmission Guard		✓
<b>VIBRATORY SYSTEM</b>			<b>ELECTRICAL</b>		
Smooth Drum	✓		24 volt Electrical System	✓	
Removable Shell Kit – Oval or Square Pads		✓	100 ampere Alternator	✓	
Pod-Style Eccentric Weight Housings	✓		750 Cold-cranking Amps Battery Capacity	✓	
Dual Amplitude, Single Frequency	✓		<b>OTHER</b>		
Variable Frequency		✓	Lockable Engine Enclosure, Hydraulic and Fuel Tanks	✓	
Auto-vibe Function	✓		Sight Gauges for Hydraulic Oil Level and Radiator Coolant Level	✓	
Single Adjustable Steel Scraper	✓		S•O•S <sup>SM</sup> Sampling Values: Engine Oil, Hydraulic Oil, and Coolant	✓	
Dual Adjustable Steel Scrapers		✓	Factory Filled Bio-Hydraulic Oil		✓
Dual Adjustable Polyurethane Scrapers		✓	Halogen Working Lights (4)	✓	
Leveling Blade		✓	Halogen Working Lights (8)		✓
<b>TECHNOLOGY SOLUTIONS</b>			Amber Rotating Beacon		✓
VisionLink	✓				
Measure – Machine Drive Power (MDP)		✓			
Measure – Compaction Meter Value (CMV)		✓			
Command for Compaction		✓			

# Cat® CS16 Smooth Drum Vibratory Soil Compactor

## Technical Specifications

### Engine and Powertrain

Engine Model	Cat C4.4	
Emissions	U.S. EPA Tier 4 Final	
Engine Power – ISO 14396:2002	129.4 kW	173.5 hp
Gross Power – SAE J1995:2014	131 kW	175.7 hp
Net Power – ISO 9249:2007*	109.7 kW	147.1 hp
Net Power – SAE J1349:2011*	108.3 kW	145.2 hp
Number of Cylinders	4	
Displacement	4.4 L	268.5 in <sup>3</sup>
Stroke	127 mm	5 in
Bore	105 mm	4.1 in
Max. Travel Speed (Forward or Reverse)	11.4 km/h	7.1 mph
Theoretical Gradeability, with or without vibration**	59%	

\* Net power advertised is the power available at the engine flywheel when equipped with a fan at maximum speed, air cleaner, clean emissions module, and alternator.

\*\* Actual gradeability may vary based on site conditions and machine configuration. Refer to the Operation and Maintenance Manual for more information.

### Vibratory System

Frequency		
Standard	28 Hz	1680 vpm
During Eco-mode Operation	25.5 Hz	1527 vpm
Optional Variable Frequency	23.3-28 Hz	1400-1680 vpm
Nominal Amplitude @ 28 Hz (1680 vpm)		
High	2.1 mm	0.083 in
Low	0.98 mm	0.039 in
Centrifugal Force @ 28 Hz (1680 vpm)		
Maximum	335 kN	75,234 lb
Minimum	156 kN	35,163 lb
VM Class at High Amplitude (Cab Configuration)	VM5	
Static Linear Load		
ROPS/FOPS Cab	49.4 kg/cm	276.6 lbs/in

### Weights

#### Operating Weight

ROPS/FOPS Cab	16 143 kg	35,589 lb
Leveling Blade	16 796 kg	37,029 lb
Oval Padfoot Shell Kit	17 545 kg	38,680 lb
Oval Padfoot Shell Kit and Leveling Blade	18 198 kg	40,120 lb

#### Weight at Drum

ROPS/FOPS Cab	10 542 kg	23,241 lb
Leveling Blade	11 498 kg	25,349 lb
Oval Padfoot Shell Kit	11 941 kg	26,325 lb
Oval Padfoot Shell Kit and Leveling Blade	12 898 kg	28,435 lb

Operating weights are approximate and consider full fluids, 80 kg (176 lb) operator, cab with heat and air conditioning.

### Service Refill Capacities

Fuel Tank	307 L	81.1 gal
Diesel Exhaust Fluid (DEF) Tank	19 L	5 gal
Cooling System	28.2 L	7.4 gal
Heating System	1.2 L	0.3 gal
Engine Oil with Filter	11.6 L	3.1 gal
Eccentric Weight Housings (combined)	26 L	6.9 gal
Axle and Final Drives	18 L	4.8 gal
Hydraulic Tank	50 L	13.2 gal

# Cat® CS16 Smooth Drum Vibratory Soil Compactor

## Technical Specifications

### Dimensions

<b>1A</b>	Overall Length	6.1 m	19.8 ft
<b>1B</b>	Optional Leveling Blade	6.5 m	21.5 ft
<b>2A</b>	Overall Width	2.3 m	7.7 ft
<b>2B</b>	Optional Leveling Blade	2.5 m	8.2 ft
<b>3</b>	Drum Width	2134 mm	84 in
<b>4</b>	Drum Shell Thickness	40 mm	1.6 in
<b>5</b>	Drum Diameter	1534 mm	60.4 in
<b>6</b>	Overall Height	3.1 m	10.2 ft
<b>7</b>	Wheelbase	2.9 m	9.5 ft
<b>8</b>	Ground Clearance	427 mm	16.8 in
<b>9</b>	Curb Clearance	489 mm	19.3 in
<b>10</b>	Optional Leveling Blade Height	683 mm	26.9 in
	Inside Turning Radius	3.7 m	12.1 ft
	Hitch Articulation Angle	34°	
	Hitch Oscillation Angle	15°	

### Optional Padfoot Shell Kits

Number of Pads	120	
Number of Chevrons	16	
Oval Pads		
Pad Height	89.1 mm	3.5 in
Pad Face Area	63.5 cm <sup>2</sup>	9.8 in <sup>2</sup>
Square Pads		
Pad Height	89.2 mm	3.5 in
Pad Face Area	105.7 cm <sup>2</sup>	16.4 in <sup>2</sup>

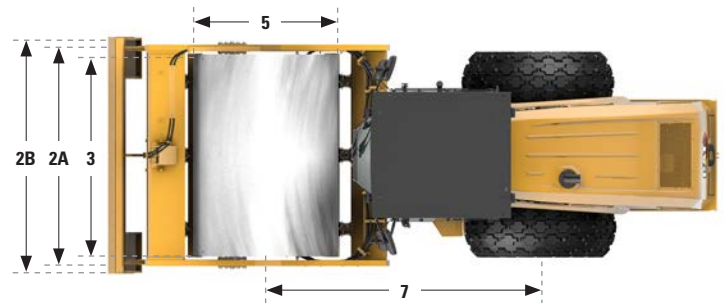
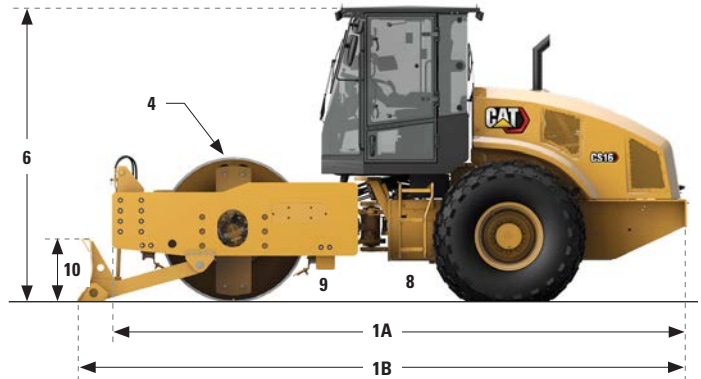

# Cat® CS16 Smooth Drum Vibratory Soil Compactor

## Environmental Declaration

The following information applies to the machine at the time of final manufacture as configured for sale in the regions covered in this document. The content of this declaration is valid as of the date issued; however, content related to machine features and specifications are subject to change without notice. For additional information, please see the machine's Operation and Maintenance Manual.

For more information on sustainability in action and our progress, please visit [www.caterpillar.com/en/company/sustainability.html](http://www.caterpillar.com/en/company/sustainability.html).

## ENGINE

- The Cat C4.4 is available in configurations that meet U.S. EPA Tier 4 Final emissions standards.
- Cat diesel engines are required to use ULSD (ultra-low sulfur diesel fuel with 15 ppm of sulfur or less) or ULSD blended with the following lower-carbon intensity fuels\* up to:
  - ✓ 20% biodiesel FAME (fatty acid methyl ester)
  - ✓ 100% renewable diesel, HVO (hydrotreated vegetable oil) and GTL (gas-to-liquid) fuels

Refer to guidelines for successful application. Please consult your Cat dealer or "Caterpillar Machine Fluids Recommendations" (SEBU6250) for details.

*\*Tailpipe greenhouse gas emissions from lower-carbon intensity fuels are essentially the same as traditional fuels.*

## AIR CONDITIONING SYSTEM

The air conditioning system on this machine contains the fluorinated greenhouse gas refrigerant R134a (Global Warming Potential = 1430). The system contains 0.8 kg (1.8 lb) of refrigerant, which has a CO<sub>2</sub> equivalent of 1.144 metric tonnes (1.261 tons).

## PAINT

- Based on best available knowledge, the maximum allowable concentration, measured in parts per million (PPM), of the following heavy metals in paint are:
  - Barium < 0.01%
  - Cadmium < 0.01%
  - Chromium < 0.01%
  - Lead < 0.01%

## SOUND PERFORMANCE

Operator Sound Pressure Level (ISO 6396:2008) with cooling fan speed at 70% of maximum value – 79 dB(A)

Exterior Sound Power Level (ISO 6395:2008) with cooling fan speed at 100% of maximum value – 108 dB(A)

- The operator sound pressure level is measured according to the test procedures and conditions specified in ISO 6396:2008 for a cab offered by Caterpillar, when properly installed and maintained and tested with the door and windows closed. The measurements were conducted at 70% of the maximum engine cooling fan speed.
- The exterior sound power level is measured according to the test procedures and conditions specified in ISO 6395:2008 for a Caterpillar machine that is properly equipped and maintained. The measurements were conducted at 100% of the maximum engine cooling fan speed.
- Hearing protection may be needed when operating with an open operator station and cab (when not properly maintained for doors/windows open) for extended periods or in noisy environment(s).

## OILS AND FLUIDS

- Caterpillar factory fills with ethylene glycol coolants. Cat Diesel Engine Antifreeze/Coolant (DEAC) and Cat Extended Life Coolant (ELC) can be recycled. Consult your Cat dealer for more information.
- Cat BIO HYDO™ Advanced is an EU Ecolabel approved biodegradable hydraulic oil.
- Additional fluids are likely to be present, please consult the Operations and Maintenance Manual or the Application and Installation guide for complete fluid recommendations and maintenance intervals.

## FEATURES AND TECHNOLOGY

- The following features and technology may contribute to fuel savings and/or carbon reduction. Features may vary. Consult your Cat dealer for details.
  - Standard Eco-mode limits engine RPM, lowering overall fuel consumption
  - Optional compaction control technology reduces unnecessary passes, increasing operating efficiency
  - Extended maintenance intervals reduce fluid and filter consumption
  - Engine Idle Shutdown Timer reduces unproductive hours and fuel burned
  - Variable speed cooling fan operates at the lowest speed for optimal cooling

## RECYCLING

- The materials included in machines are categorized as below with approximate weight percentage. Because of variations of product configurations, the following values in the table may vary.

Material Type	Weight Percentage
Steel	79.40%
Iron	5.96%
Nonferrous Metal	1.04%
Mixed Metal	0.01%
Mixed-Metal and Nonmetal	1.57%
Plastic	0.96%
Rubber	0.76%
Mixed Nonmetallic	0.13%
Fluid	1.61%
Other	2.27%
Uncategorized	6.30%
Total	100%

- A machine with higher recyclability rate will ensure more efficient usage of valuable natural resources and enhance End-of-Life value of the product. According to ISO 16714:2008 (Earthmoving machinery – Recyclability and recoverability – Terminology and calculation method), recyclability rate is defined as percentage by mass (mass fraction in percent) of the new machine potentially able to be recycled, reused or both.

All parts in the bill of material are first evaluated by component type based on a list of components defined by the ISO 16714:2008 and Japan CEMA (Construction Equipment Manufacturers Association) standards. Remaining parts are further evaluated for recyclability based on material type.

Because of variations of product configurations, the following value in the table may vary.

Recyclability – 96%



# Cat® CS16 Smooth Drum Vibratory Soil Compactor

---

For more complete information on Cat products, dealer services, and industry solutions, visit us on the web at [www.cat.com](http://www.cat.com)

© 2023 Caterpillar  
All rights reserved

Materials and specifications are subject to change without notice. Featured machines in photos may include additional equipment.  
See your Cat dealer for available options.

CAT, CATERPILLAR, LET'S DO THE WORK, their respective logos, "Caterpillar Corporate Yellow," the "Power Edge" and Cat "Modern Hex" trade dress as well as corporate and product identity used herein, are trademarks of Caterpillar and may not be used without permission.

VisionLink is a trademark of Caterpillar Inc., registered in the United States and in other countries.

QEHO3097 (12-2023)  
Build Number: 03A  
(N Am)

