



Cat[®] CS14

Smooth Drum Vibratory Soil Compactor

The Cat[®] CS14 Vibratory Soil Compactor features a smooth drum and is ideally suited for granular soil applications or cohesive soil applications with the use of an optional padfoot shell kit. A reliable propel system improves performance and efficiency and compaction technology solutions help you reach target density faster.

Efficient Power

- Built around a dual pump propel system, two pumps provide separate dedicated flow to the drum drive motor and rear axle motor for exceptional gradeability and traction in forward and reverse.
- Powered by a Cat[®] C7.1 engine that emits equivalent to U.S. EPA Tier 3 and EU Stage IIIA.
- Eco-mode limits engine RPM helping to reduce fuel consumption.
- Engine Idle Shutdown Timer reduces fuel burn and unnecessary idle time by shutting down the machine after a pre-set idling period.
- A variable speed cooling fan operates at the lowest possible speed for optimal cooling.
- Bolt-on leveling blade option increases machine versatility.

Exceptional Compaction Performance

- High static linear loads and amplitudes.
- Exclusive eccentric weight design provides high reliability, smooth performance and low noise.
- Automatic Speed Control and Auto-vibe functions make it easy to ensure consistent, high-quality compaction.
- The Variable Frequency option provides a wide range of frequencies to help maximize compaction performance.
- Increase machine versatility with the addition of an oval or square padfoot shell kit, allowing your smooth drum machine to compact semi-cohesive and cohesive materials.

Safe and Comfortable Work Environment

- A rear vision camera with large color touchscreen display enhances visibility for more complete operator control and safety.
- The pivoting seat with integrated multifunction LCD display and control console move with the operator.
- Outstanding visibility to the front and rear of machine.
- Low sound levels and vibration for greater operator comfort and productivity.
- Operators are protected from the elements by a standard equipped sun canopy, optional ROPS/FOPS canopy or optional climate-controlled ROPS/FOPS cab with hinged glass windows.

Enhance Quality and Productivity with Technology

- Optional Cat Compact technologies help you consistently meet compaction targets faster, more uniformly, and in fewer passes – saving on fuel and reducing rework and material costs.
 - Exclusive Machine Drive Power (MDP) is an energy-based measurement and can be used on all soil types.
 - Compaction Meter Value (CMV) is an accelerometer-based measurement for granular soils.



Cat® CS14 Smooth Drum Vibratory Soil Compactor

Virtually Maintenance Free

- Maintenance-free hitch with sealed-for-life bearings.
- Ground-level access to the engine compartment and cooling module for easy service and fluid sampling.
- Monitor fluid conditions with regular sampling to help extend change intervals up to 500 hours engine oil, 3000 hours eccentric housing and hydraulic oil, and 12000 hours coolant.
- Extended maintenance intervals not only reduce downtime but decrease the amount of fluid and filters that are replaced over the life of the machine.

- VisionLink® takes the guesswork out of managing your entire fleet—regardless of size or equipment manufacturer*—by providing maintenance needs, machine hours, location, fuel usage, idle time, diagnostic codes, and more through interactive dashboards on your mobile device or desktop, helping you make informed decisions that lower costs, simplify maintenance, and improve safety and security on your jobsite.

* Data field availability can vary by equipment manufacturer and is provided through an application programming interface (API).

Vibratory Soil Compactor Selection Guide

This chart helps you select which model is best suited for your work. Not all models listed are available in each region. Contact your Cat dealer representative for more information.

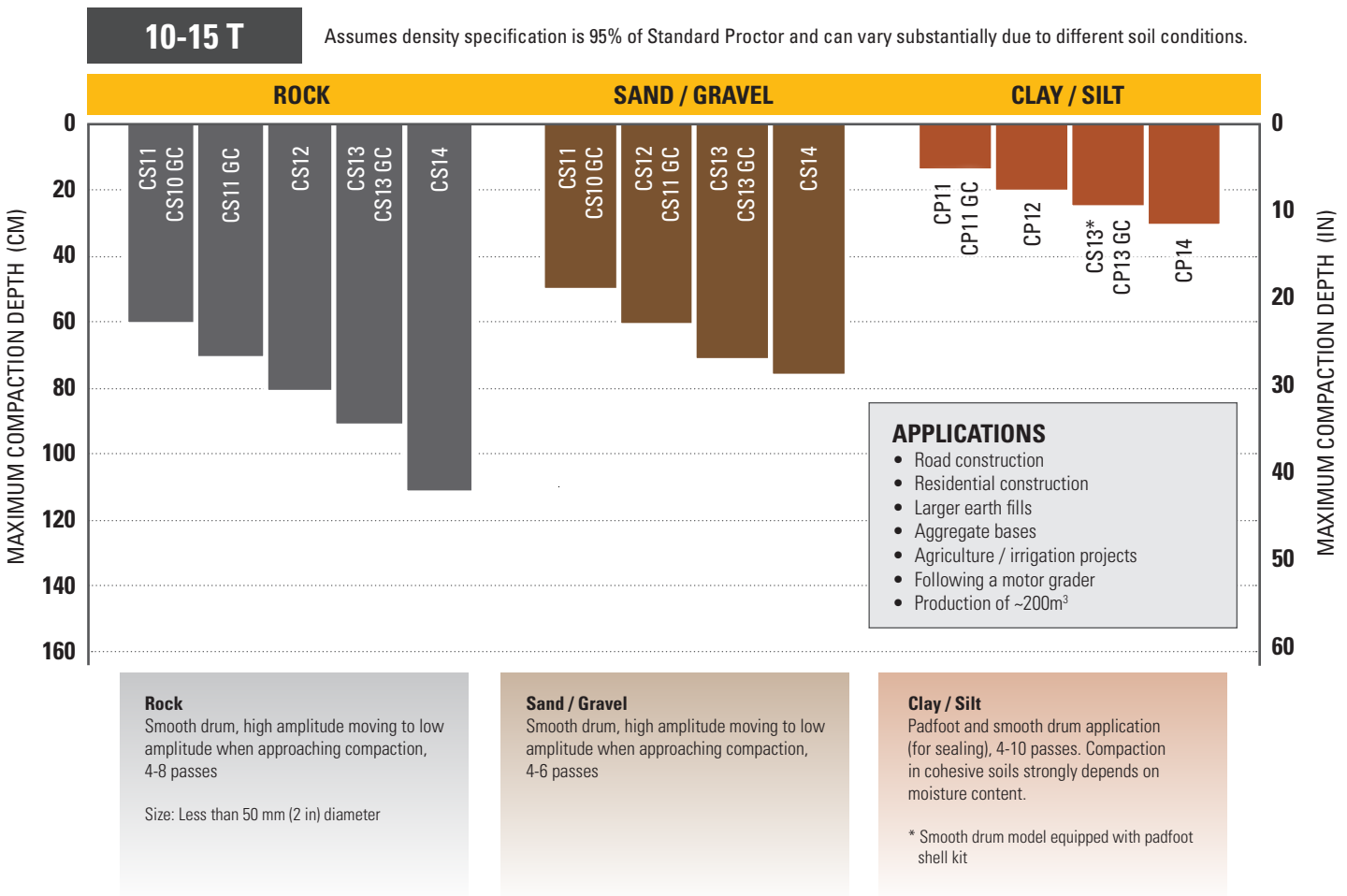

Cat® CS14 Smooth Drum Vibratory Soil Compactor

Standard and Optional Equipment

Standard and optional equipment may vary. Consult your Cat dealer for details.

	Standard	Optional		Standard	Optional
OPERATOR ENVIRONMENT			POWERTRAIN		
Steel Sun Canopy with Handrails, Floor Mat, Vinyl Seat	✓		Cat® C7.1 Engine	✓	
ROPS/FOPS Canopy with Handrails, Floor Mat, Vinyl Seat		✓	Air Cleaner, Dual Element	✓	
ROPS/FOPS Cab with Climate Control, Cloth Seat, Exterior Rear View Mirrors		✓	Three Speed Throttle Switch including Eco-mode	✓	
Sun Visor (Cab)		✓	Automatic Speed Control (ASC)	✓	
Roll-Down Screen (Cab)		✓	Dual Propel Pumps; One for Drum Drive, One for Rear Axle	✓	
Adjustable Seat with Integrated Console	✓		Fuel Filter, Water Separator, Priming Pump, Water Indicator	✓	
LCD Display with Lockable Vandalism Guard	✓		Tilting Radiator / Hydraulic Oil Cooler	✓	
Adjustable Tilting Steering Column with Integrated Cup Holders	✓		Dual Braking System	✓	
Rear Vision Camera System with Color Touchscreen Display	✓		Two-Speed Hydrostatic Transmission	✓	
High Visibility 50 mm (2 in) Seat Belt	✓		Limited Slip Differential	✓	
12-volt Power Outlet	✓		Transmission Guard		✓
Horn, Backup Alarm	✓		ELECTRICAL		
VIBRATORY SYSTEM			24 volt Electrical System	✓	
Smooth Drum	✓		100 ampere Alternator	✓	
Removable Shell Kit – Oval or Square Pads		✓	750 Cold-cranking Amps Battery Capacity	✓	
Pod-Style Eccentric Weight Housings	✓		OTHER		
Dual Amplitude, Single Frequency	✓		Lockable Engine Enclosure, Hydraulic and Fuel Tanks	✓	
Variable Frequency		✓	Sight Gauges for Hydraulic Oil Level and Radiator Coolant Level	✓	
Auto-vibe Function	✓		S•O•S SM Sampling Values: Engine Oil, Hydraulic Oil, and Coolant	✓	
Single Adjustable Steel Scraper	✓		Halogen Working Lights (4)	✓	
Dual Adjustable Steel Scrapers		✓	Halogen Working Lights (8)		✓
Dual Adjustable Polyurethane Scrapers		✓	Amber Rotating Beacon		✓
Leveling Blade		✓			
TECHNOLOGY SOLUTIONS					
VisionLink®	✓				
Measure – Machine Drive Power (MDP)		✓			
Measure – Compaction Meter Value (CMV)		✓			

Cat® CS14 Smooth Drum Vibratory Soil Compactor

Technical Specifications

Engine and Powertrain

Engine Model	Cat C7.1	
Emissions	U.S. EPA Tier 3, EU Stage IIIA equivalent	
Engine Power – ISO 14396:2002	116.1 kW	155.7 hp
Gross Power – SAE J1995:2014	117.5 kW	157.6 hp
Net Power – ISO 9249:2007*	98.2 kW	131.7 hp
Net Power – SAE J1349:2011*	97 kW	130.1 hp
Number of Cylinders	6	
Displacement	7 L	427.8 in ³
Stroke	135 mm	5.3 in
Bore	105 mm	4.1 in
Max. Travel Speed (Forward or Reverse)	11.4 km/h	7.1 mph
Theoretical Gradeability, with or without vibration**	57%	

* Net power advertised is the power available at the engine flywheel when equipped with a fan at maximum speed, air cleaner, and alternator.

** Actual gradeability may vary based on site conditions and machine configuration. Refer to the Operation and Maintenance Manual for more information.

Vibratory System

Frequency		
Standard	30.5 Hz	1830 vpm
During Eco-mode Operation	27.7 Hz	1664 vpm
Optional Variable Frequency	23.3-30.5 Hz	1400-1830 vpm
Nominal Amplitude @ 30.5 Hz (1830 vpm)		
High	2.1 mm	0.083 in
Low	0.98 mm	0.039 in
Centrifugal Force @ 30.5 Hz (1830 vpm)		
Maximum	301 kN	67,653 lb
Minimum	141 kN	31,680 lb
VM Class at High Amplitude (Cab Configuration)	VM4	
Static Linear Load		
Steel Sun Canopy	42 kg/cm	235.2 lbs/in
ROPS/FOPS Canopy	42.3 kg/cm	236.7 lbs/in
ROPS/FOPS Cab	42.5 kg/cm	238 lbs/in

Weights

Operating Weight

Steel Sun Canopy	13 895 kg	30,633 lb
ROPS/FOPS Canopy	14 070 kg	31,019 lb
ROPS/FOPS Cab	14 245 kg	31,405 lb

Weight at Drum

Steel Sun Canopy	8965 kg	19,764 lb
ROPS/FOPS Canopy	9020 kg	19,886 lb
ROPS/FOPS Cab	9069 kg	19,994 lb

Overall Weight Increase with Optional Attachments

Oval Padfoot Shell Kit	1517 kg	3344 lb
Square Padfoot Shell Kit	1676 kg	3695 lb
Leveling Blade	653 kg	1440 lb

Operating weights are approximate and consider full fluids and 80 kg (176 lb) operator. Cab weights include heat and air conditioning.

Optional attachment weight reflects the overall weight of the attachment itself, not the weight of the attachment installed on the machine.

Service Refill Capacities

Fuel Tank	242 L	63.9 gal
Cooling System	31.9 L	8.4 gal
Heating System	1.2 L	0.3 gal
Engine Oil with Filter	17.4 L	4.6 gal
Eccentric Weight Housings (combined)	26 L	6.9 gal
Axle and Final Drives	18 L	4.8 gal
Hydraulic Tank	50 L	13.2 gal

Cat® CS14 Smooth Drum Vibratory Soil Compactor

Technical Specifications

Dimensions

1A	Overall Length	6.1 m	19.8 ft
1B	Optional Leveling Blade	6.5 m	21.5 ft
2A	Overall Width	2.3 m	7.7 ft
2B	Optional Leveling Blade	2.5 m	8.2 ft
3	Drum Width	2134 mm	84 in
4	Drum Shell Thickness	30 mm	1.2 in
5	Drum Diameter	1534 mm	60.4 in
6	Overall Height		
	Canopy	3.1 m	10.2 ft
	Cab	3.1 m	10.2 ft
7	Wheelbase	2.9 m	9.5 ft
8	Ground Clearance	428 mm	16.9 in
9	Curb Clearance	487 mm	19.2 in
10	Optional Leveling Blade Height	683 mm	26.9 in
	Inside Turning Radius	3.7 m	12.1 ft
	Hitch Articulation Angle	34°	
	Hitch Oscillation Angle	15°	

Optional Padfoot Shell Kits

	Number of Pads	120	
	Number of Chevrons	16	
	Oval Pads		
	Pad Height	89.1 mm	3.5 in
	Pad Face Area	63.5 cm ²	9.8 in ²
	Square Pads		
	Pad Height	89.2 mm	3.5 in
	Pad Face Area	105.7 cm ²	16.4 in ²

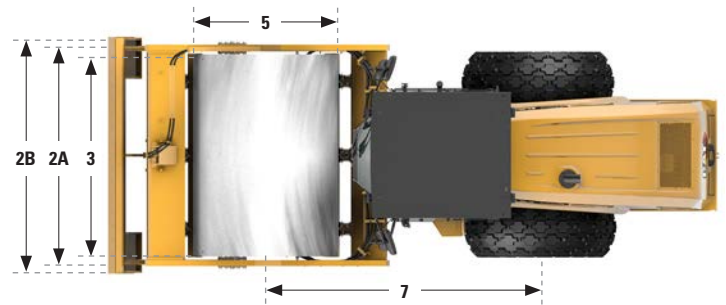
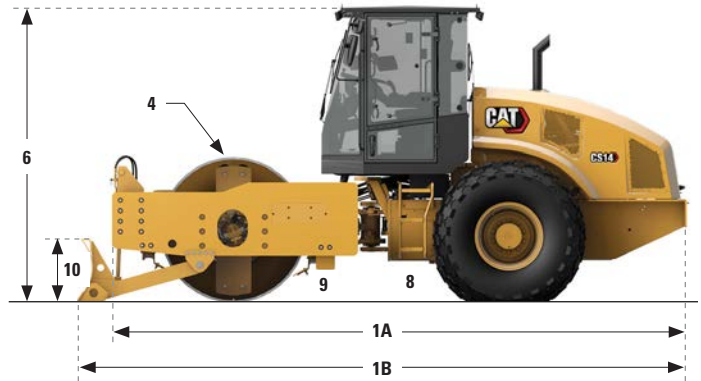

Cat® CS14 Smooth Drum Vibratory Soil Compactor

Environmental Declaration

The following information applies to the machine at the time of final manufacture as configured for sale in the regions covered in this document. The content of this declaration is valid as of the date issued; however, content related to machine features and specifications are subject to change without notice. For additional information, please see the machine's Operation and Maintenance Manual.

For more information on sustainability in action and our progress, please visit www.caterpillar.com/en/company/sustainability.html.

ENGINE

- The Cat C7.1 emits equivalent to U.S. EPA Tier 3, EU Stage IIIA.
- Cat engines are compatible with diesel fuel blended with the following lower-carbon intensity fuels* up to:
 - ✓ 20% biodiesel FAME (fatty acid methyl ester)
 - ✓ 100% renewable diesel, HVO (hydrotreated vegetable oil) and GTL (gas-to-liquid) fuels

Refer to guidelines for successful application. Please consult your Cat dealer or "Caterpillar Machine Fluids Recommendations" (SEBU6250) for details.

**Tailpipe greenhouse gas emissions from lower-carbon intensity fuels are essentially the same as traditional fuels.*

AIR CONDITIONING SYSTEM

The air conditioning system on this machine contains the fluorinated greenhouse gas refrigerant R134a (Global Warming Potential = 1430). The system contains 0.8 kg (1.8 lb) of refrigerant, which has a CO₂ equivalent of 1.144 metric tonnes (1.261 tons).

PAINT

- Based on best available knowledge, the maximum allowable concentration, measured in parts per million (PPM), of the following heavy metals in paint are:
 - Barium < 0.01%
 - Cadmium < 0.01%
 - Chromium < 0.01%
 - Lead < 0.01%

SOUND PERFORMANCE

Operator Sound Pressure Level (ISO 6396:2008) with cooling fan speed at 70% of maximum value – 80 dB(A)

Exterior Sound Power Level (ISO 6395:2008) with cooling fan speed at 100% of maximum value – 109 dB(A)

- The operator sound pressure level is measured according to the test procedures and conditions specified in ISO 6396:2008 for a cab offered by Caterpillar, when properly installed and maintained and tested with the door and windows closed. The measurements were conducted at 70% of the maximum engine cooling fan speed.
- The exterior sound power level is measured according to the test procedures and conditions specified in ISO 6395:2008 for a Caterpillar machine that is properly equipped and maintained. The measurements were conducted at 100% of the maximum engine cooling fan speed.
- Hearing protection may be needed when operating with an open operator station and cab (when not properly maintained for doors/windows open) for extended periods or in noisy environment(s).

OILS AND FLUIDS

- Caterpillar factory fills with ethylene glycol coolants. Cat Diesel Engine Antifreeze/Coolant (DEAC) and Cat Extended Life Coolant (ELC) can be recycled. Consult your Cat dealer for more information.
- Cat BIO HYDO™ Advanced is an EU Ecolabel approved biodegradable hydraulic oil.
- Additional fluids are likely to be present, please consult the Operations and Maintenance Manual or the Application and Installation guide for complete fluid recommendations and maintenance intervals.

FEATURES AND TECHNOLOGY

- The following features and technology may contribute to fuel savings and/or carbon reduction. Features may vary. Consult your Cat dealer for details.
 - Standard Eco-mode limits engine RPM, lowering overall fuel consumption
 - Optional compaction control technology reduces unnecessary passes, increasing operating efficiency
 - Extended maintenance intervals reduce fluid and filter consumption
 - Engine Idle Shutdown Timer reduces unproductive hours and fuel burned
 - Variable speed cooling fan operates at the lowest speed for optimal cooling

RECYCLING

- The materials included in machines are categorized as below with approximate weight percentage. Because of variations of product configurations, the following values in the table may vary.

Material Type	Weight Percentage
Steel	77.92%
Iron	6.44%
Nonferrous Metal	1.12%
Mixed Metal	0.01%
Mixed-Metal and Nonmetal	1.75%
Plastic	1.01%
Rubber	0.40%
Mixed Nonmetallic	0.14%
Fluid	1.78%
Other	0.25%
Uncategorized	6.94%
Total	100%

- A machine with higher recyclability rate will ensure more efficient usage of valuable natural resources and enhance End-of-Life value of the product. According to ISO 16714:2008 (Earthmoving machinery – Recyclability and recoverability – Terminology and calculation method), recyclability rate is defined as percentage by mass (mass fraction in percent) of the new machine potentially able to be recycled, reused or both.

All parts in the bill of material are first evaluated by component type based on a list of components defined by the ISO 16714:2008 and Japan CEMA (Construction Equipment Manufacturers Association) standards. Remaining parts are further evaluated for recyclability based on material type.

Because of variations of product configurations, the following value in the table may vary.

Recyclability – 96%

Cat® CS14 Smooth Drum Vibratory Soil Compactor

For more complete information on Cat products, dealer services, and industry solutions, visit us on the web at www.cat.com

© 2023 Caterpillar
All rights reserved

Materials and specifications are subject to change without notice. Featured machines in photos may include additional equipment.
See your Cat dealer for available options.

CAT, CATERPILLAR, LET'S DO THE WORK, their respective logos, "Caterpillar Corporate Yellow," the "Power Edge" and Cat "Modern Hex" trade dress as well as corporate and product identity used herein, are trademarks of Caterpillar and may not be used without permission.

VisionLink is a trademark of Caterpillar Inc., registered in the United States and in other countries.

QEHO3095 (12-2023)
Build Number: 03A
(U.S. EPA Tier 3, EU Stage IIIA)

