

# 428/432/434/444

## BACKHOE LOADERS



	428	432	434	444
<b>Engine Power</b>	55 kW, 70 kW, or 74.4 kW	74.4 kW or 82 kW	74.4 kW	74.4 kW or 82 kW
<b>Operating Weight</b>	8270 kg (55.4 kW Engine) 8345 kg (70 kW/74.5 kW Engine)	8469 kg	9170 kg	9462 kg
<b>Dig Depth</b>	4778 mm (5700 mm) (E-Stick)	4778 mm (6150 mm) (E-Stick)	4827 mm (5748 mm) (E-Stick)	4827 mm (6218 mm) (E-Stick)
<b>Loader Breakout Force</b>	54.8 kN	54.8 kN	60.7 kN	60.7 kN
<b>Controls</b>	Mechanical Levers (Joysticks Optional)	Electro Hydraulic Seat Mounted Joysticks	Mechanical Levers (Joysticks Optional)	Electro Hydraulic Seat Mounted Joysticks

\*Engine meets EU Stage V emission standards.



## ORIGINAL DNA

The first Cat® backhoe loader hit the road in 1985. The machine was co-developed by a team of designers in Illinois, U.S. and a manufacturing team in Desford, UK. The machines are still designed by experts to meet the needs of today's operators. Every model provides reliability, power and a top-quality operator environment to see you through the toughest projects. The latest backhoe loader range is crafted from 35 years of passion, expertise and experience.

# CAT®

# SIDE SHIFT BACKHOE LOADERS

## TAKE CONTROL IN YOUR CAT BACKHOE LOADER



### MORE CONTROL FOR YOU

- + **SAVE FUEL** – SAVE UP TO 10% IN FUEL WITH THE CAT C3.6 ENGINE (COMPARED TO PREVIOUS GENERATION OF MACHINES), WHICH IS DESIGNED TO MEET THE LATEST EMISSIONS STANDARDS.
- + **RANGE OF CONTROL OPTIONS** – SELECT YOUR COMFORT OPTION: MECHANICAL, PILOT OR SEAT-MOUNTED ELECTRO-HYDRAULIC CONTROLS GIVING MORE COMFORT AND CONTROL THAN EVER BEFORE.
- + **CHOOSE YOUR SETTINGS** – USE THE DISPLAY SCREEN TO SET YOUR PERSONAL OPERATOR PREFERENCES, SO YOU CAN WORK AT A PACE THAT SUITS YOU, EVERY TIME.
- + **EASY TO OWN AND OPERATE** – WITH MONTHLY PAYMENT OPTIONS, FUEL SAVINGS AND BEST-QUALITY PARTS AND ENGINEERING, IT'S EASIER AND MORE AFFORDABLE THAN EVER TO OWN AND OPERATE A CAT BACKHOE LOADER.



## **POWERFUL LOAD SENSING** **HYDRAULIC SYSTEM**

---

### **FLOW-SHARING VALVES**

Actively manage the flow of oil between each function of the machine. When the operator demands multiple operations the machine responds, providing smooth, effortless operation.

---

### **LIFTING PERFORMANCE**

The option of a larger boom cylinder (fitted as standard on 432 and 444) is available on the 428 and 434 giving increased lifting performance against the standard boom cylinder. This option is available with either mechanical or pilot controls.

---

### **VARIABLE DISPLACEMENT PISTON PUMP**

A high capacity variable displacement piston pump allows for perfect matching of power and operator demand, providing power when it is needed while contributing to great fuel economy.

---

### **MORE COMFORT AND CONTROL**

The 432 and 444 are available with electro-hydraulic controls, and the operator can customize both the speed and responsiveness of all hydraulic commands on both the loader and excavator end of the machine to get the perfect feeling of control. This, as well as the pattern changer, is managed through the display screen. Adjustable auxiliary flow can also be adjusted through the display screen allowing the operator to perfectly match machine and attachment.

# BACKHOES

BUILT FOR THE TASK



## HIGH-ROTATION LINKAGE

The Cat backhoe linkage provides an industry-leading 205 degrees of bucket rotation. This design helps with material retention when truck loading and with vertical wall-trenching. Improved performance and efficiency are achieved by the ability to do more with less movement.

## EXCAVATOR-STYLE BOOM

Whether close-up truck loading or digging over obstacles, the iconic excavator-style boom tackles the toughest jobs with ease. Combine this versatility with powerful breakout forces, controllability, and a powerful hydraulic system, the Cat Backhoe Loader is capable of high levels of productivity with minimum effort. The boom is a narrow design, ensuring maximum visibility to the attachment and ground. On the 432 and 444, the hoe comes with the choice of either a 4.3 m or 4.9 m stick option.

## CAT CUSHION SWING

The standard Cat Cushion Swing System smooths the backhoe swing function when returning to the trench. Operators will immediately appreciate being able to line up the bucket edge on the trench wall faster and with more control.

## SIDE SHIFT FRAME

The Side Shift Frame has exterior lock clamps, with no disassembly needed when servicing. The frame is a solid design with E-Coat protection preventing material build up in the frame, reducing the risk of rust and increasing the life of the frame.

## EXTENDIBLE STICK

The extendible stick comes as an option for applications where more versatility is needed. Increasing dig depth and reach capability by 921 mm reduces the amount of machine repositioning and therefore reducing site damage and increasing productivity. A sliding inner section design helps to ensure the wear pads remain as dirt free as possible, prolonging adjustment and replacement intervals. Auxiliary lines, for operating hydraulic attachments, have been routed so that they are protected from damage when working in the narrowest of trenches.

## POWERED SIDE SHIFT (OPTIONAL)

Available as an option either from the factory or as a dealer fitted kit, the powered side shift solution provides a hydraulic service to allow the operator to easily position the backhoe across the full width of the Side Shift Frame. Ideal for use in areas with minimal space and utility applications such as gas, electrical, and telecoms.

## POWER TRAIN

# POWERFUL, PROVEN AND EFFICIENT

## C3.6 ENGINE

The Cat C3.6 engine, which meets EU Stage V emission standards, reduces owning and operating costs while maintaining the same performance and power as the C4.4 engine. The aftertreatment is a compact, maintenance-free solution of Diesel Oxidation Catalyst (DOC), Selective Catalytic Reduction (SCR) and Diesel Particulate Filter (DPF). The Cat C3.6 engine is a turbocharged in-line four-cylinder, four-stroke cycle with direct injection diesel engine. Cold starting capability down to  $-25^{\circ}\text{C}$  comes as standard with a cold starting package option allowing the machine to start down to  $-47^{\circ}\text{C}$ . This engine has a 12 volt starting motor with a 750 CCA maintenance-free battery. This engine gives up to 10% fuel savings, based upon application and machine setting, compared to the C4.4 engine.

## POWER MANAGEMENT MODES

Three power management modes are available: Eco, Standard and Standard Plus. Depending upon application or performance needs, the operator can select the mode that gives optimum results. Eco mode limits both pump flow and engine speed giving higher fuel saving benefits whereas Standard Plus gives maximum pump flow and engine speed, providing increased power and performance where needed.

## TRANSMISSIONS

The 4-speed manual transmission with a floor mounted gear shift lever is available as the entry level offering. Improved operator comfort and reduced fatigue are achieved with the 4-speed powershift transmission using the directional control lever to shift gears. The 6-speed automatic shift transmission is an available option, providing greater efficiency by ensuring that the correct gear is always selected. The Lock-up Torque Converter option is ideal for those who do a lot of roading as it can give up to 15% fuel efficiency savings on the road and maintain travel speed in hilly environments.

## EQUAL SIZED TIRES (EST)

With four equal sized tires, the 434 and 444 models are capable of increased lifting performance. Better flotation makes an EST ideal for applications with poor ground conditions. The EST machines also offer all wheel steering to improve maneuverability around the job site.

## AXLES AND DIFFERENTIAL LOCK

Heavy duty axles and a 100% locking rear differential come as standard on Cat backhoe loaders. The axles provide high durability whilst providing superb traction on uneven surfaces. No daily greasing is required on the front axle helping to save both time and money, keeping owning and operating costs as low as possible. The Diff-lock improves performance by giving maximum traction in all conditions.





## LOADER PERFORMANCE

### MAKING LIGHT WORK OF LIFTING AND LOADING

#### PARALLEL LIFT

---

Parallel lift loader arms offer excellent forward visibility and self-leveling, ensuring excellent material retention throughout the lift and lower cycles.

#### RIDE CONTROL

---

This option offers loader suspension to improve operator comfort and productivity. When moving around the job site or transporting the machine on the road, ride control provides extra stability which creates an easier ride for the operator and helps material retention to improve operator efficiency.

#### RETURN TO DIG

---

Return to Dig allows the operator to return the bucket to a preset level, this is great for applications with repetitive work cycles especially when working with forks. When not required, for instance when grading with the loader bucket, Return to Dig can be turned off within the display screen.

#### INTEGRATED TOOLCARRIER (IT) QUICK COUPLER (QC)

---

This option is available from the factory or as a dealer fitted kit, providing the extra versatility needed when working in multiple applications. This coupler allows a quick and safe change between multiple attachments from the inside of the cab.

# OPERATOR ENVIRONMENT

## CUSTOMIZE YOUR EXPERIENCE TO INCREASE PRODUCTIVITY AND EFFICIENCY

### LCD OPERATOR DISPLAY

The LCD operator display comes standard as a softkey display or can be upgraded to touchscreen. Through the interactive display you can get updates on machine diagnostics and upcoming service intervals, as well as being able to configure various performance parameters dependent on configuration. This helps to match machine performance to operator preference further increasing productivity and efficiency. Both displays have a speedometer on the home page allowing operators to check their ground speed whilst on the move. Optional machine security system is embedded into the display screen helping to keep your Cat backhoe loader secure and retains the selected machine settings by security code. The touchscreen display includes a QR code linking operators to an operator training page where they will find videos highlighting key operation and maintenance support.



### OPERATOR COMFORT

The air suspension seat comes standard with switches and controls ergonomically located within reach of the operator. Diff-Lock button, Transmission kickdown and auxiliary controls are all located on the loader control giving power and control at the operator's fingertips. Great visibility allows the operator to get the job done in a safe and efficient manner. A heated seat offering is available for those wanting the additional comfort in cold conditions.



### SEAT-MOUNTED CONTROLS

Seat mounted Electro Hydraulic Controls are available as standard on the 432 and 444. The loader or excavator can be operated from any seated position, even whilst sat offset helping to improve productivity and performance all in a safe and efficient manner. The Electro Hydraulic solution also offers operators the ability to speed up or slow down the hydraulics to match machine performance to either their preference or the job at hand.



### PILOT JOYSTICK CONTROLS

Pilot Joystick Controls are available as an option on the 428 and 434. The controls to operate the excavator end are mounted on fully adjustable pods that the operator can position to their preference. These controls increase operator comfort by having them located in the most ergonomic position as well as being more accessible and smoother to operate than the standard mechanical controls. The loader joystick control includes a thumb roller for operating the auxiliary hydraulics as well as a F-N-R switch to support quick loading cycles.

# ATTACHMENTS

A WIDE RANGE OF CATERPILLAR ATTACHMENTS ARE AVAILABLE TO MEET THE NEEDS OF YOUR JOB SITE APPLICATIONS.

Our attachments are engineered, balanced and tested to each Cat backhoe loader model, promising to minimize stress and optimize performance.

## LOADER BUCKETS

General Purpose (GP) loader buckets are available as well as the hydraulically operated Multi-Purpose (MP) bucket.

### OTHER AVAILABLE LOADER TOOLS INCLUDE:

- + BROOMS
- + MATERIAL HANDLING ARMS
- + TRUSS BOOMS
- + FORKS
- + BLADES

## EXCAVATING BUCKETS

Cat Attachments provide a range of buckets in various sizes. It is easy to find the correct bucket for the application with a range including:

- + STANDARD DUTY
- + HEAVY DUTY
- + HIGH CAPACITY HD
- + DITCH CLEANING
- + CRIBBING
- + GRADING
- + TRAPEZOIDAL
- + DUAL CYLINDER TILTING

### OTHER AVAILABLE BACKHOE TOOLS INCLUDE:

- + COLD PLANERS
- + HAMMERS
- + AUGERS
- + VIBRATORY COMPACTION PLATES
- + RIPPER

## BACKHOE QUICK COUPLER

Manual or hydraulic backhoe couplers make rear tool exchange quick, easy and safe. Cat dual-lock couplers have a self-adjusting wedge design to ensure a tight fit. They also feature a safety lock which automatically engages.





EASY TO OPERATE

# EASY TO MAINTAIN

## DAILY SERVICE POINTS

Caterpillar understands that the easier a task is the more likely it is to be done. We have ensured that servicing the Cat backhoe loader is as simple as it can be. All daily check points are grouped together and are easy to access from a large service platform.

## HINGED COOLING PACK

The hood opens to reveal the engine and a unique Cat designed hinged cooling pack. The air conditioning pack lifts up and the radiator tilts forward with no tooling required, giving easy access for debris removal whether you are in the workshop or on a job site, keeping optimal cooling performance.

## WEAR PAD ADJUSTMENTS

The Extendible Stick (E-Stick) is designed to be self-lubricating, to minimize the need for operator interaction. The stabilizers and E-Stick all have easily adjustable wear pads that require no disassembly. When wear pad adjustments are necessary, the adjustment bolts are easy to access, taking minutes to complete.

## CAT FILTERS

All Cat filters are vertically mounted for spill free servicing and reduced oil contamination. These low micron filters remove microscopic particles from the oil, keeping the engine, transmission and hydraulic system running smoothly for years.

## SERVICE LIGHTING

Optional service lighting places LED spotlights both under the hood and in the battery box. These allow operators access to daily check points like the battery and quick disconnect switch in all weather and lighting situations.

## BATTERY/STORAGE BOX

The batteries and battery disconnect switch are conveniently located in the external right hand side lockable storage box for easy access. The box also leaves sufficient space to be able to store grease gun, spanner, etc.



# YOUR MACHINE

## YOUR SUPPORT



### MACHINE SELECTION

---

Your dealer can help you with your machine purchase decision, based on your requirements and help keep operating costs to a minimum. Is the machine you have in mind exactly the best for your job, or could there be a more suitable solution?

### CUSTOMER VALUE AGREEMENTS (CVA'S)

---

Your Cat dealer can offer a comprehensive range of CVA's which can be individually tailored to suit your requirements. Dealers can offer a range of options from a full preventative maintenance with Scheduled Oil Sampling (S·O·S<sup>SM</sup>) package to a parts only CVA. Protect your valuable investment and know exactly what your monthly payments will be to help you run your business.

### EQUIPMENT PROTECTION PLAN (EPP)

---

You count on your Cat machines to get the job done, day in and day out. Choose a protection plan that's just as dependable and long-lasting. EPP offers the only coverage designed specifically for new Cat equipment – giving you the highest level of repair cost protection available. Talk to your dealer today to find out what EPP solution is the best for you!

### FINANCE

---

Have you explored the range of options available from your dealer to finance your machine? They can offer a selection of attractive packages tailored to suit your every requirement.

### TRAINING AND SUPPORT

---

Speak to your dealer about any additional support you may need. They can give you the latest in operating techniques to minimize wear and tear, maximize productivity, lower owning and operating costs and help you make the most of the fantastic features offered on the Cat backhoe loaders.

# TECHNICAL SPECIFICATIONS

See *cat.com* for complete specifications.

ENGINE	55.4 KW	70 KW	74.4 KW	82 KW
MACHINE	428	428	428/432/434/444	432/444
<b>Ratings at 2,200 rpm</b>				
<b>Gross Peak Power SAE J1995:2014</b>	55.8 kW/76 hp (@2200 RPM)	71.3 kW/97 hp (@2200 RPM)	83.1 kW/113 hp (@1800 RPM)	86.5 kW/118 hp (@1800 RPM)
<b>Engine Power ISO 14396:2002 @ 2200 RPM</b>	55.4 kW/75 hp	70 kW/95 hp	74.4 kW/101 hp	82 kW/111 hp
<b>Torque Rise (net)</b>	86% @ 1,200 rpm	43% @ 1,500 rpm	48% @ 1,500 rpm	48% @ 1,500 rpm
<b>Gross Peak Torque – SAE J1995</b>	423 N·m	413 N·m	454 N·m	504 N·m
<b>Bore</b>	98 mm	98 mm	98 mm	98 mm
<b>Stroke</b>	120 mm	120 mm	120 mm	120 mm
<b>Displacement</b>	3.6 L	3.6 L	3.6 L	3.6 L

- All hp figures using DIN metric horsepower.
- No derating required up to 3048 m altitude. Auto derate protects hydraulic and transmission systems.
- Meets EU Stage V emission standards.
- Advertised power is tested per the specified standard in effect at the time of manufacture.

TRANSMISSION	STANDARD SHIFT TRANSMISSION	POWERSHIFT TRANSMISSION	AUTOSHIFT TRANSMISSION	AUTOSHIFT TRANSMISSION WITH LOCK-UP TORQUE CONVERTER
MACHINE	428/434	428/432/434	428/432/434/444	428/432/434/444
<b>Forward</b>				
<b>1st</b>	6 km/hr	6 km/hr	6 km/hr	6 km/hr
<b>2nd</b>	9 km/hr	10 km/hr	10 km/hr	10 km/hr
<b>3rd</b>	21 km/hr	20 km/hr	13 km/hr	13 km/hr
<b>4th</b>	40 km/hr	40 km/hr	20 km/hr	20 km/hr
<b>5th</b>	—	—	27 km/hr	27 km/hr
<b>6th</b>	—	—	40 km/hr	40 km/hr
<b>Reverse</b>				
<b>1st</b>	6 km/hr	6 km/hr	6 km/hr	6 km/hr
<b>2nd</b>	9 km/hr	13 km/hr	13 km/hr	13 km/hr
<b>3rd</b>	21 km/hr	27 km/hr	27 km/hr	27 km/hr
<b>4th</b>	40 km/hr	—	—	—

- Travel speeds of 428 and 432 backhoe loader at full throttle, when equipped with 480/80-26 rear tires.
- Travel speeds of 434 and 444 backhoe loader at full throttle, when equipped with 440/80-28 rear tires.

# TECHNICAL SPECIFICATIONS

See [cat.com](http://cat.com) for complete specifications.

WEIGHTS*				
<b>Machine</b>	428	432	434	444
<b>Operating Weight*</b>	8270 kg (55 kW) 8345 kg (70 kW/ 74.5 kW)	8469 kg	9170 kg	9462 kg
<b>Operating Weight (maximum) (Rollover Protective Structure [ROPS] capacity)</b>	11 000 kg	11 000 kg	11 500 kg	11 500 kg
<b>Cab, ROPS/Falling Object Protective Structure (FOPS)</b>	Standard	Standard	Standard	Standard
<b>Autoshift Transmission</b>	96 kg	109 kg	109 kg	109 kg
<b>Ride Control</b>	15 kg	15 kg	15 kg	15 kg
<b>MP Bucket (1.03 m³)</b>				
with Fold-over Forks	860 kg	860 kg	—	—
without Fold-over Forks	674 kg	674 kg	—	—
<b>MP Bucket (1.15 m³)</b>				
with Fold-over Forks	—	—	975 kg	—
without Fold-over Forks	—	—	776 kg	—
<b>MP Bucket (1.3 m³)</b>				
with Fold-over Forks	—	—	—	1020 kg
without Fold-over Forks	—	—	—	841 kg
<b>Loader QC</b>	185 kg	185 kg	185 kg	185 kg
<b>4.3 m Extendible Stick</b>	208 kg	199 kg	203 kg	199 kg
<b>4.9 m Extendible Stick</b>	—	355 kg	—	355 kg
<b>Minimum Counterweight Recommendations – Standard Stick</b>				
<b>Loader Bucket GP</b>	115 kg	115 kg	0 kg	0 kg
<b>Loader Bucket MP</b>	0 kg	0 kg	0 kg	0 kg
<b>Loader QC</b>	0 kg	0 kg	115 kg	115 kg
<b>Minimum Counterweight Recommendations – 4.3 m Extendible Stick</b>				
<b>Loader Bucket GP</b>	460 kg	460 kg	0 kg	0 kg
<b>Loader Bucket MP</b>	0 kg	0 kg	0 kg	0 kg
<b>Loader QC</b>	240 kg	240 kg	115 kg	115 kg
<b>Minimum Counterweight Recommendations – 4.9 m Extendible Stick</b>				
<b>Loader Bucket GP</b>	—	460 kg	—	0 kg
<b>Loader Bucket MP</b>	—	240 kg	—	0 kg
<b>Loader QC</b>	—	460 kg	—	115 kg
<b>Total Gross Weight Not to Exceed</b>	11 000 kg	11 000 kg	11 500 kg	11 500 kg
*Machine Configuration – 4.3 m standard stick hoe; standard cab with A/C; 600 mm standard duty hoe bucket; no counterweight; 80 kg operator; full fuel tank; 428 – 55 kW/70 kW HRC engine; AWD standard shift transmission; 1.03 m³ MP loader bucket; 340/80-20 and 480/80-26 tires; One Way Auxiliary Lines; AWD Guard; Front Fenders; HD Battery. 432 – 74.5 kW HRC engine; AWD powershift transmission; 1.03 m³ MP loader bucket; 340/80-20 and 480/80-26 tires; One Way Auxiliary Lines; AWD Guard; Front Fenders; HD Battery. 434 – 74.5 kW HRC engine; AWD standard shift transmission; 1.15 m³ MP loader bucket; 440/80R24 tires. 444 – 74.5 kW HRC engine; AWD autoshift transmission; 1.3 m³ MP loader bucket; 440/80R28 tires.				

AXLE RATINGS		
<b>Machine</b>	428/432	434/444
<b>Front Axle, AWD</b>		
<b>Static</b>	23 500 kg	22 964 kg
<b>Dynamic</b>	9000 kg	9186 kg
<b>Rear Axle</b>		
<b>Static</b>	26 500 kg	22 964 kg
<b>Dynamic</b>	10 000 kg	9186 kg

HYDRAULIC SYSTEM		
<b>Machine</b>	428/434	432/444
<b>Type</b>	Closed Center	Closed Center
<b>Pump Type</b>	Variable-Flow, Axial Piston	Variable-Flow, Axial Piston
<b>Pump Capacity @ 2,200 rpm</b>	160 L/min	187 L/min
<b>System Pressure</b>		
<b>Backhoe</b>	250 bar	250 bar
<b>Loader</b>	250 bar	250 bar

STEERING		
<b>Machine</b>	428/432	434/444
<b>Type</b>	Front Wheel	Front Wheel
<b>Power Steering</b>	Hydrostatic	Hydrostatic
<b>AWD Cylinder, One (1) Double-acting</b>		
<b>Bore</b>	65 mm	85 mm
<b>Stroke</b>	106 mm	117 mm
<b>Rod Diameter</b>	40 mm	42 mm
<b>Axle Oscillation</b>	8 mm	8 mm
<b>Turning Circle</b>		
<b>AWD (inner wheel not braked)</b>		
<b>Outside Front Wheels</b>	9,273 mm	9,800 mm
<b>Outside Widest Loader Bucket</b>	11,622 mm	12,590 mm

SERVICE REFILL CAPACITIES		
<b>Machine</b>	428/432	434/444
<b>Cooling System with A/C</b>	18 L	17.5 L
<b>Fuel Tank</b>	160 L	160 L
<b>Engine Oil with Filter</b>	9 L	9 L
<b>Diesel Exhaust Fluid</b>	19 L	19 L
<b>Transmission (Standard Shift)</b>	18 L	18 L
<b>Transmission (Powershift/Autoshift)</b>	19 L	19 L
<b>Rear Axle</b>	16 L	16 L
<b>Planetaries</b>	1.7 L	1.7 L
<b>Front Axle</b>	11 L	14 L
<b>Planetaries</b>	0.7 L	1.7 L
<b>Hydraulic System</b>	95 L	95 L
<b>Hydraulic Tank</b>	42 L	42 L

# 428 AND 432 TECHNICAL SPECIFICATIONS

See [cat.com](http://cat.com) for complete specifications.

## MACHINE DIMENSIONS

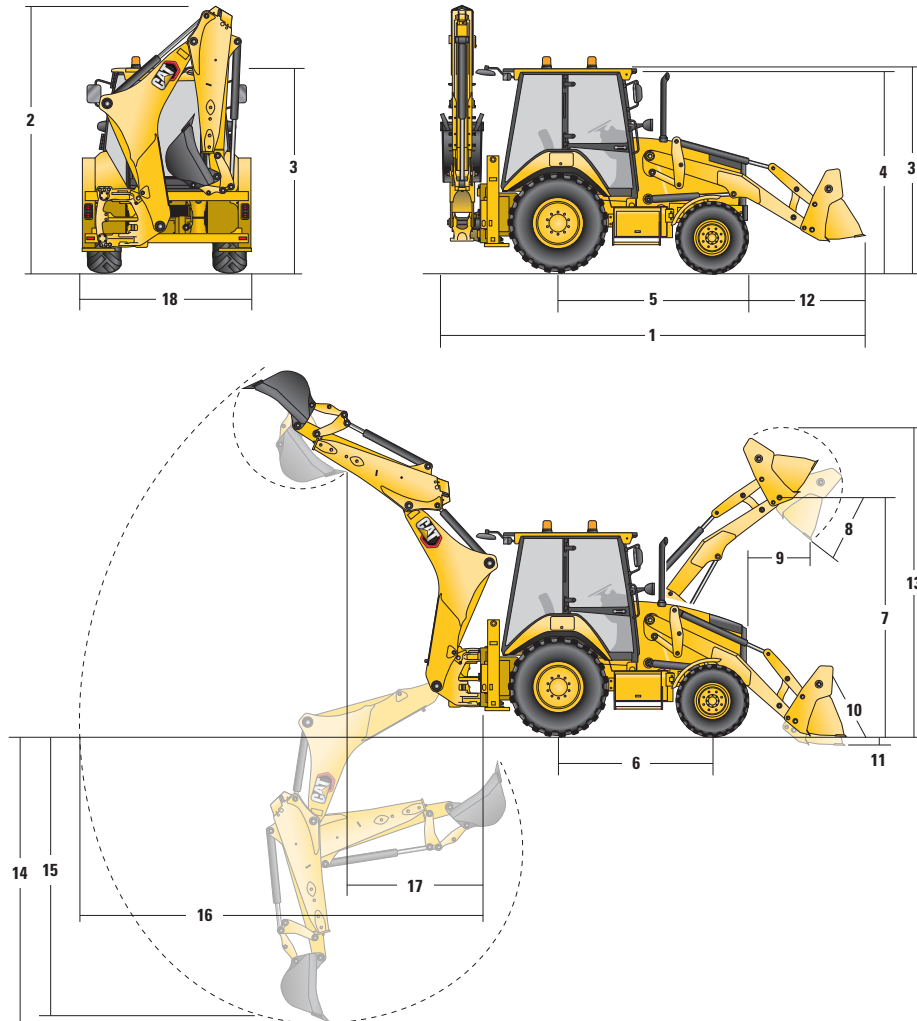

	Parallel Lift Loader			Parallel Lift Loader with QC	
	GP – 1.0 m <sup>3</sup>	MP – 1.03 m <sup>3</sup>	MP with Forks – 1.03 m <sup>3</sup>	GP/QC – 1.0 m <sup>3</sup>	MP/QC – 1.03 m <sup>3</sup>
<b>1</b> Overall Length in Rooding Position	5747 mm	5728 mm	5728 mm	5832 mm	5744 mm
Overall Transportation Length	5754 mm	5711 mm	5711 mm	5864 mm	5758 mm
<b>2</b> Overall Transportation Height	3786 mm	3786 mm	3786 mm	3786 mm	3786 mm
Overall Width	2352 mm	2352 mm	2352 mm	2352 mm	2352 mm
<b>3</b> Height to Top of Cab/Canopy	2835 mm	2835 mm	2835 mm	2835 mm	2835 mm
<b>4</b> Height to Top of Exhaust Stack	2731 mm	2731 mm	2731 mm	2731 mm	2731 mm
<b>5</b> Rear Axle Centerline to Front Grill	2705 mm	2705 mm	2705 mm	2705 mm	2705 mm
<b>6</b> Wheelbase	2200 mm	2200 mm	2200 mm	2200 mm	2200 mm

Dimensions and performance specifications shown are for machines equipped with 340/80-20 front tires, 480/80-26 rear tires, Std Cab, E-Stick, 610 mm standard duty bucket, and 1.03 m<sup>3</sup> MP loader bucket and standard equipment unless otherwise specified.

# 428 AND 432 TECHNICAL SPECIFICATIONS

See [cat.com](http://cat.com) for complete specifications.

LOADER BUCKET DIMENSIONS AND PERFORMANCE					
	Parallel Lift Loader			Parallel Lift Loader with QC	
	GP – 1.0 m <sup>3</sup>	MP – 1.03 m <sup>3</sup>	MP with Forks – 1.03 m <sup>3</sup>	GP/QC – 1.0 m <sup>3</sup>	MP/QC – 1.03 m <sup>3</sup>
<b>Capacity (SAE rated)</b>	1.0 m <sup>3</sup>	1.03 m <sup>3</sup>	1.03 m <sup>3</sup>	1.03 m <sup>3</sup>	1.03 m <sup>3</sup>
<b>Width</b>	2406 mm	2406 mm	2406 mm	2406 mm	2406 mm
<b>Lift Capacity at Maximum Height</b>	3765 kg	3525 kg	3340 kg	3546 kg	3315 kg
<b>Lift Breakout Force</b>	54 658 N	53 161 N	51 449 N	51 543 N	50 732 N
<b>Tilt Breakout Force</b>	54 221 N	59 763 N	58 818 N	48 159 N	53 312 N
<b>Tipping Load at Breakout Point</b>	6838 kg	6821 kg	6666 kg	6287 kg	6481 kg
<b>7 Maximum Hinge Pin Height</b>	3492 mm	3492 mm	3492 mm	3492 mm	3492 mm
<b>8 Dump Angle at Full Height</b>	45°	45°	45°	45°	45°
<b>  Dump Height at Maximum Angle</b>	2789 mm	2813 mm	2813 mm	2703 mm	2782 mm
<b>9 Dump Reach at Maximum Angle</b>	805 mm	732 mm	732 mm	838 mm	784 mm
<b>10 Maximum Bucket Rollback at Ground Level</b>	38°	38°	38°	39°	38°
<b>11 Digging Depth</b>	67 mm	101 mm	101 mm	106 mm	86 mm
<b>  Maximum Grading Angle</b>	114°	116°	116°	112°	114°
<b>12 Grill to Bucket Cutting Edge, Carry Position</b>	1474 mm	1457 mm	1457 mm	1558 mm	1473 mm
<b>13 Maximum Operating Height</b>	4358 mm	4395 mm	4395 mm	4391 mm	4437 mm
<b>Weight (does not include teeth)</b>	438 kg	674 kg	860 kg	456 kg	693 kg

Dimensions and performance specifications shown are for machines equipped with 340/80-20 front tires, 480/80-26 rear tires, Standard cab, E-Stick, 610 mm standard duty bucket, and 1.03 m<sup>3</sup> MP loader bucket and standard equipment unless otherwise specified.

BACKHOE DIMENSIONS AND PERFORMANCE					
	432 only				
	Standard Stick – 4.3 m	E-stick Retracted – 4.3 m	E-stick Extended – 4.3 m	E-stick Retracted – 4.9 m	E-stick Extended – 4.9 m
<b>14 Digging Depth, SAE Maximum</b>	4297 mm	4300 mm	5290 mm	4636 mm	5665 mm
<b>  Digging Depth, Manufacturer's Maximum</b>	4778 mm	4764 mm	5682 mm	5181 mm	6150 mm
<b>15 Digging Depth, 2400 mm Flat Bottom</b>	3914 mm	3918 mm	4985 mm	4293 mm	5373 mm
<b>  Digging Depth, 600 mm Flat Bottom</b>	4254 mm	4257 mm	5251 mm	4611 mm	5631 mm
<b>  Digging Depth, 600 mm Flat Bottom, Manufacturer's</b>	4734 mm	4738 mm	5682 mm	5144 mm	6131 mm
<b>  Reach from Rear Axle Centerline at Ground Line</b>	6740 mm	6746 mm	7672 mm	7217 mm	8169 mm
<b>16 Reach from Swing Pivot at Ground Line</b>	5650 mm	5656 mm	6582 mm	6127 mm	7079 mm
<b>  Maximum Operating Height</b>	5664 mm	5664 mm	6260 mm	6230 mm	6953 mm
<b>  Loading Height</b>	3990 mm	3999 mm	4595 mm	4554 mm	5277 mm
<b>17 Loading Reach</b>	1702 mm	1650 mm	2515 mm	1573 mm	2335 mm
<b>  Swing Arc</b>	180°	180°	180°	180°	180°
<b>  Bucket Rotation</b>	205°	205°	205°	205°	205°
<b>18 Stabilizer Overall Width</b>	2352 mm	2352 mm	2352 mm	2352 mm	2352 mm
<b>  Bucket Dig Force</b>	63 445 N	63 417 N	63 417 N	63 426 N	63 426 N
<b>  Stick Dig Force 428:</b>	36 225 N	36 891 N	26 967 N	—	—
<b>  Stick Dig Force 432:</b>	42 829 N	43 540 N	31 743 N	47 244 N	35 171 N

Dimensions and performance specifications shown are for machines equipped with 340/80-20 front tires, 480/80-26 rear tires, Standard cab, E-Stick, 610 mm standard duty bucket, and 1.03 m<sup>3</sup> MP loader bucket and standard equipment unless otherwise specified.

# 434 AND 444 TECHNICAL SPECIFICATIONS

See [cat.com](http://cat.com) for complete specifications.

## MACHINE DIMENSIONS

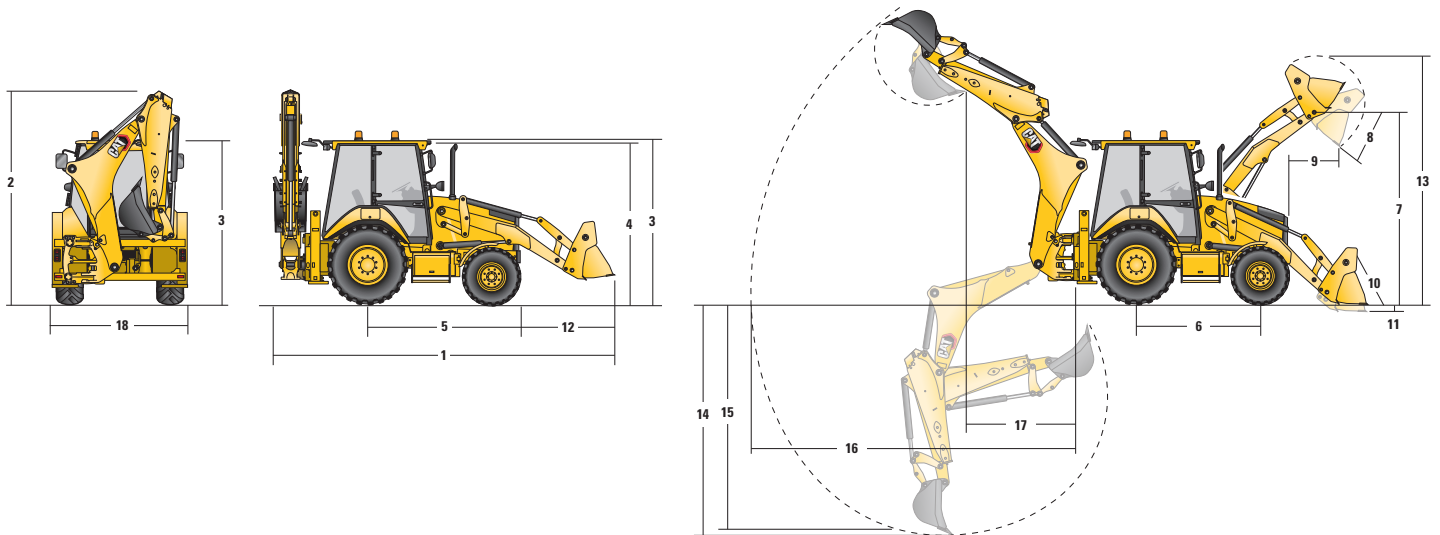

	Parallel Lift Loader			Parallel Lift Loader with QC	
	GP – 1.3 m <sup>3</sup>	MP – 1.3 m <sup>3</sup>	MP with Forks – 1.3 m <sup>3</sup>	GP/QC – 1.3 m <sup>3</sup>	MP/QC – 1.3 m <sup>3</sup>
<b>1</b> Overall Length in roading position	5824 mm	5847 mm	5847 mm	5840 mm	5877 mm
Overall Transportation Length	5859 mm	5889 mm	5889 mm	5933 mm	5978 mm
<b>2</b> Overall Transport Height (standard stick)	3826 mm	3826 mm	3826 mm	3826 mm	3826 mm
Overall Transport Height (extendible stick) (4.9 m)	4005 mm	4005 mm	4005 mm	4005 mm	4005 mm
Overall Width	2322 mm	2322 mm	2322 mm	2322 mm	2322 mm
<b>3</b> Height to Top of Cab/Canopy	2897 mm	2897 mm	2897 mm	2897 mm	2897 mm
<b>4</b> Height to Top of Exhaust Stack	2861 mm	2861 mm	2861 mm	2861 mm	2861 mm
<b>5</b> Rear Axle Centerline to Front Grill	2795 mm	2795 mm	2795 mm	2795 mm	2795 mm
<b>6</b> Wheelbase AWD	2235 mm	2235 mm	2235 mm	2235 mm	2235 mm

Dimensions and performance specifications shown are for machines equipped with 440/80R28 rear tires, standard cab, standard stick with 600 mm standard duty bucket, and 1.3 m<sup>3</sup> MP loader bucket and standard equipment unless otherwise specified.

	1.15 m <sup>3</sup> Buckets		
	GP – 1.15 m <sup>3</sup>	MP – 1.15 m <sup>3</sup>	MP with Forks – 1.15 m <sup>3</sup>
<b>1</b> Overall Length in Roading Position	5852 mm	5840 mm	5840 mm
Overall Transportation Length	5921 mm	5900 mm	5877 mm
<b>2</b> Overall Transportation Height	3780 mm	3780 mm	3780 mm
Overall Width	2322 mm	2322 mm	2322 mm
<b>3</b> Height to Top of Cab/Canopy	2875 mm	2875 mm	2875 mm
<b>4</b> Height to Top of Exhaust Stack	2783 mm	2783 mm	2783 mm
<b>5</b> Rear Axle Centerline to Front Grill	2795 mm	2795 mm	2795 mm
<b>6</b> Wheelbase AWD	2235 mm	2235 mm	2235 mm

Dimensions and performance specifications shown are for machines equipped with 440/80R24 tires, standard cab, standard stick with 600 mm standard duty bucket, no counterweight, 1.15m<sup>3</sup> MP loader bucket and standard equipment unless otherwise specified.

# 434 AND 444 TECHNICAL SPECIFICATIONS

See [cat.com](http://cat.com) for complete specifications.

LOADER BUCKET DIMENSIONS AND PERFORMANCE			
	1.15 m <sup>3</sup> Buckets		
	GP – 1.15 m <sup>3</sup>	MP – 1.15 m <sup>3</sup>	MP with Forks – 1.15 m <sup>3</sup>
Capacity (SAE rated)	1.15 m <sup>3</sup>	1.15 m <sup>3</sup>	1.15 m <sup>3</sup>
Width	2434 mm	2434 mm	2434 mm
Lift Capacity at Maximum Height	4626 kg	4303 kg	4118 kg
Lift Breakout Force	60 977 N	58 278 N	56 714 N
Tilt Breakout Force	63 092 N	63 334 N	62 809 N
Tipping Load at Breakout Point	6858 kg	6669 kg	6579 kg
7 Maximum Hinge Pin Height	3518 mm	3518 mm	3518 mm
8 Dump Angle at Full Height	45°	45°	45°
Dump Height at Maximum Angle	2745 mm	2760 mm	2779 mm
9 Dump Reach at Maximum Angle	923 mm	908 mm	907 mm
10 Maximum Bucket Rollback at Ground Level	44°	44°	44°
11 Digging Depth	154 mm	153 mm	142 mm
Maximum Grading Angle	109°	110°	110°
12 Grill to Bucket Cutting Edge, Carry Position	1491 mm	1479 mm	1459 mm
13 Maximum Operating Height	4397 mm	4463 mm	4463 mm
Weight (does not include teeth)	448 kg	776 kg	975 kg

Dimensions and performance specifications shown are for machines equipped with 440/80R24 tires, standard cab, standard stick with 600 mm standard duty bucket, no counterweight, 1.15m<sup>3</sup> MP loader bucket and standard equipment unless otherwise specified.

LOADER BUCKET DIMENSIONS AND PERFORMANCE					
	1.3 m <sup>3</sup> Buckets			Parallel Lift Loader with QC	
	GP – 1.3 m <sup>3</sup>	MP – 1.3 m <sup>3</sup>	MP with Forks – 1.3 m <sup>3</sup>	GP/QC – 1.3 m <sup>3</sup>	MP/QC – 1.3 m <sup>3</sup>
Capacity (SAE rated)	1.3 m <sup>3</sup>	1.3 m <sup>3</sup>	1.3 m <sup>3</sup>	1.3 m <sup>3</sup>	1.3 m <sup>3</sup>
Width	2434 mm	2434 mm	2434 mm	2434 mm	2434 mm
Lift Capacity at Maximum Height	4663 kg	4310 kg	4130 kg	4416 kg	4046 kg
Lift Breakout Force	60 672 N	57 112 N	55 303 N	57 809 N	53 966 N
Tilt Breakout Force	62 442 N	58 441 N	57 041 N	55 980 N	50 955 N
Tipping Load at Breakout Point	7503 kg	7109 kg	6937 kg	7054 kg	6606 kg
7 Maximum Hinge Pin Height	3615 mm	3615 mm	3615 mm	3615 mm	3615 mm
8 Dump Angle at Full Height	45°	45°	45°	45°	45°
Dump Height at Maximum Angle	2847 mm	2826 mm	2826 mm	2794 mm	2763 mm
9 Dump Reach at Maximum Angle	923 mm	944 mm	944 mm	971 mm	1008 mm
10 Maximum Bucket Rollback at Ground Level	42°	42°	42°	42°	42°
11 Digging Depth	56 mm	56 mm	56 mm	59 mm	55 mm
Maximum Grading Angle	111°	111°	111°	110°	108°
12 Grill to Bucket Cutting Edge, Carry Position	1464 mm	1488 mm	1488 mm	1482 mm	1518 mm
13 Maximum Operating Height	4617 mm	4621 mm	4621 mm	4663 mm	4685 mm
Weight (does not include teeth)	472 kg	827 kg	1020 kg	637 kg	989 kg

Dimensions and performance specifications shown are for machines equipped with 440/80R24 tires, standard cab, standard stick with 600 mm standard duty bucket, no counterweight, 1.15m<sup>3</sup> MP loader bucket and standard equipment unless otherwise specified.



# 434 AND 444 TECHNICAL SPECIFICATIONS

See [cat.com](http://cat.com) for complete specifications.

BACKHOE DIMENSIONS AND PERFORMANCE					
	Standard Stick	E-stick Retracted – 4.3 m	E-stick Extended – 4.3 m	E-stick Retracted – 4.9 m	E-stick Extended – 4.9 m
<b>14 Digging Depth, SAE Maximum</b>	4331 mm	4335 mm	5312 mm	4686 mm	5707 mm
<b>Digging Depth, Manufacturer's Maximum</b>	4826 mm	4831 mm	5747 mm	5271 mm	6218 mm
<b>15 Digging Depth, 2400 mm Flat Bottom</b>	3956 mm	3960 mm	5022 mm	4341 mm	5416 mm
<b>Digging Depth, 600 mm Flat Bottom</b>	4288 mm	4291 mm	5278 mm	4654 mm	5671 mm
<b>Digging Depth, 600 mm Flat Bottom, Manufacturer's</b>	4818 mm	4823 mm	5744 mm	5244 mm	6215 mm
<b>Reach from Rear Axle Centerline at Ground Line</b>	6742 mm	6748 mm	7673 mm	7219 mm	8171 mm
<b>16 Reach from Swing Pivot at Ground Line</b>	5652 mm	5658 mm	6583 mm	6129 mm	7081 mm
<b>Maximum Operating Height</b>	5596 mm	5595 mm	6163 mm	6172 mm	6869 mm
<b>Loading Height</b>	3927 mm	3938 mm	4505 mm	4495 mm	5192 mm
<b>17 Loading Reach</b>	1808 mm	1758 mm	2641 mm	1696 mm	2482 mm
<b>Swing Arc</b>	180°	180°	180°	180°	180°
<b>Bucket Rotation</b>	205°	205°	205°	205°	205°
<b>18 Stabilizer Overall Width</b>	2352 mm	2352 mm	2352 mm	2352 mm	2352 mm
<b>Bucket Dig Force</b>	63 433 N	63 404 N	63 404 N	63 414 N	63 414 N
<b>Stick Dig Force</b>	42 770 N	43 468 N	31 646 N	47 173 N	35 084 N

Dimensions and performance specifications shown are for machines equipped with 440/80R28 rear tires, standard cab, standard stick with 600 mm standard duty bucket, and 1.3 m<sup>3</sup> MP loader bucket and standard equipment unless otherwise specified.

# STANDARD AND OPTIONAL EQUIPMENT

Standard and optional equipment may vary by region. Consult your Cat dealer for details.

MACHINE	428	432	434	444
<b>CAB ROPS AND FOPS</b>				
Cab, Standard	S	S	S	S
Cab, Deluxe	O	O	O	O
<b>TIRES/STEERING/BRAKES</b>				
All Wheel Drive	S	S	S	S
All Wheel Steer	NA	NA	S	S
100% Differential Lock	S	S	S	S
Hydraulic Boosted Brakes	S	S	S	S
Front Tires, 18 Inch	S	S	NA	NA
Front Tires, 20 Inch	O	O	NA	NA
Rear Tires, 26 Inch	O	O	NA	NA
Rear Tires, 28 Inch	S	S	NA	NA
Front and Rear Tires, 24 Inch	NA	NA	S	S
Front and Rear Tires, 28 Inch	NA	NA	O	O
<b>ENGINE/TRANSMISSION</b>				
Engine, C3.6 55.4 kW	S	NA	NA	NA
Engine, C3.6 70 kW	O	NA	NA	NA
Engine, C3.6 74.4 kW	O	S	S	S
Engine, C3.6 82 kW	NA	O	NA	O
Battery, 750 CCA, Standard	S	S	S	S
Battery, 750 CCA, Heavy Duty	O	O	O	O
Hinged Radiator Pack	S	S	S	S
Auto Idle	O	S	O	S
Eco Mode	O	S	O	S
Standard Mode	S	S	S	S
Standard + Mode	O	S	O	S
Engine Block Heater	O	O	O	O
Transmission Neutralizer	S	S	S	S
F-N-R on Loader Joystick	O	S	O	S
Transmission, Four Speed Standard Shift	S	NA	S	NA
Transmission, Four Speed Powershift	O	S	O	NA
Transmission, Six Speed Autoshift (not on 55 kW Engine)	O	O	O	S
Transmission, Six Speed Autoshift with Lock-Up Torque Converter (not on 55 kW engine)	O	O	O	O
<b>CONTROLS</b>				
Controls, Electro Hydraulic Seat Mounted Joysticks	NA	S	NA	S
Controls, Mechanical Levers	S	NA	S	NA
Controls, Pilot Joysticks	O	NA	O	NA
Pattern Selector (ISO/SAE)	O	S	O	O
Power Steering, Hydrostatic	S	S	S	S

S = STANDARD  
O = OPTIONAL  
NA = Not Available

**Not all features are available in all regions. Please check with your local Cat dealer for specific offering availability in your area.**

For additional information, refer to the Technical Specifications brochure available at [www.cat.com](http://www.cat.com) or your Cat dealer.

# STANDARD AND OPTIONAL EQUIPMENT

Standard and optional equipment may vary by region. Consult your Cat dealer for details.

MACHINE	428	432	434	444
<b>ELECTRICAL</b>				
Display Screen, Soft Key	S	S	S	S
Display Screen, Touchscreen	O	O	O	O
Product Link™, Cellular	S	S	S	S
Product Link, Dual Mode (cellular and satellite)	O	O	O	O
Reversing Alarm	S	S	S	S
Stabilizer Alarm	S	S	S	S
Beacon, Strobe	O	O	O	O
Worklights, Halogen	S	S	S	S
Worklights, LED	O	O	O	O
Roading Lights, Halogen	S	S	S	S
Roading Lights, LED	O	O	O	O
<b>HYDRAULICS</b>				
Variable Displacement Piston Pump	S	S	S	S
Hydraulic Quick Disconnects	O	O	O	O
Side Shift Lock	S	S	S	S
Hydraulic Oil Cooler	S	S	S	S
Hydraulic Lines, One Way	O	O	O	O
Hydraulic Lines, Two Way	O	O	O	O
Loader Kickout, Float	S	S	S	S
Loader Kickout, Return to Dig	S	S	S	S
Powered Side Shift	O	O	O	O
Ride Control	O	O	O	O
Continuous Flow	O	S	O	S
Programmable Auxiliary Flow	O	S	O	S
<b>BOOMS, STICKS AND LINKAGES</b>				
Stick Standard, 4.3 m	S	S	S	S
Stick Extending, 4.3 m	O	O	O	O
Stick Extending, 4.9 m	NA	O	NA	O
Hoe Quick Coupler, Mechanical	O	O	O	O
Hoe Quick Coupler, Hydraulic	O	O	O	O
Loader Quick Coupler, Hydraulic	O	O	O	O
Transport Lock, Swing	S	S	S	S
Transport Lock, Boom	S	S	S	S
<b>OTHER ATTACHMENTS</b>				
Counterweight, 115 kg	O	O	O	O
Counterweight, 240 kg	O	O	NA	NA
Counterweight, 460 kg	O	O	NA	NA
Front Fenders	O	O	O	O
Street Pads, Stabilizers	O	O	O	O
External Tool Box	S	S	S	S
Transport Tie Downs	S	S	S	S
S = STANDARD O = OPTIONAL NA = Not Available				

Not all features are available in all regions. Please check with your local Cat dealer for specific offering availability in your area.

For additional information, refer to the Technical Specifications brochure available at [www.cat.com](http://www.cat.com) or your Cat dealer.

# Side Shift Backhoe Loaders Environmental Declaration

The following information applies to the machine at the time of final manufacture as configured for sale in the regions covered in this document. The content of this declaration is valid as of the date issued; however, content related to machine features and specifications are subject to change without notice. For additional information, please see the machine's Operation and Maintenance Manual.

For more information on sustainability in action and our progress, please visit <https://www.caterpillar.com/en/company/sustainability>.

## Engine

- The Cat® C3.6 engine meets EU Stage V emission standards.
  - Cat diesel engines are required to use ULSD (ultra-low sulfur diesel fuel with 15 ppm of sulfur or less) or ULSD blended with the following lower-carbon intensity fuels\* up to:
    - ✓ 20% biodiesel FAME (fatty acid methyl ester)
    - ✓ 100% renewable diesel, HVO (hydrotreated vegetable oil) and GTL (gas-to-liquid) fuels
- Refer to guidelines for successful application. Please consult your Cat dealer or "Caterpillar Machine Fluids Recommendations" (SEBU6250) for details.
- \*Tailpipe greenhouse gas emissions from lower-carbon intensity fuels are essentially the same as traditional fuels.*

## Air Conditioning System

- The air conditioning system on this machine contains the fluorinated greenhouse gas refrigerant R134a or R1234yf. See the label or instruction manual for identification of the gas. If equipped with R134a (Global Warming Potential = 1430), the system contains 1.6 kg (3.5 lb) of refrigerant which has a CO<sub>2</sub> equivalent of 2.3 metric tonnes (2.5 tons).

## Paint

- Based on best available knowledge, the maximum allowable concentration, measured in parts per million (PPM), of the following heavy metals in paint are:
  - Barium < 0.01%
  - Cadmium < 0.01%
  - Chromium < 0.01%
  - Lead < 0.01%

## Sound Performance

Operator Sound Pressure Level  
(ISO 6396:2008) – 76 dB(A)\*

Exterior Sound Power Level  
(SAE J88 JUNE 2013) – 77 dB(A)

Engine	428	432	434	444
55.4 kW	101 dB	—	—	—
70 kW	102 dB	—	—	—
74.4 kW	103 dB	103 dB	103 dB	103 dB
82 kW	—	103 dB	-	103 dB

\*Measurements were conducted with properly installed and maintained cab doors and windows closed.

## Oils and Fluids

- Caterpillar factory fills with ethylene glycol coolants. Cat Diesel Engine Antifreeze/Coolant (DEAC) and Cat Extended Life Coolant (ELC) can be recycled. Consult your Cat dealer for more information.
- Cat Bio HYDO™ Advanced is an EU Ecolabel approved biodegradable hydraulic oil.
- Additional fluids are likely to be present, please consult the Operations and Maintenance Manual or the Application and Installation guide for complete fluid recommendations and maintenance intervals.

## Features and Technology

- The following features and technology may contribute to fuel savings and/or carbon reduction. Features may vary. Consult your Cat dealer for details.
  - Extended maintenance intervals not only reduce downtime but decrease the amount of fluid and filters that are replaced over the life of the machine.
  - Auto Idle helps reduce unnecessary fuel burn and greenhouse gas emissions by allowing the engine to automatically go into idle mode when the machine is not working.

## Recycling

- The materials included in machines are categorized as below with approximate weight percentage. Because of variations of product configurations, the following values in the table may vary.

Material Type	Weight Percentage
Steel	62.73
Iron	13.68
Other	6.33
Rubber	4.53
Uncategorized	3.81
Fluid	3.66
Nonferrous Metal	2.61
Plastic	2.12
Mixed Metal	0.48
Mixed Nonmetallic	0.04
Mixed-Metal & Nonmetal	0.01
Total	100.00%

- A machine with higher recyclability rate will ensure more efficient usage of valuable natural resources and enhance End-of-Life value of the product. According to ISO 16714:2008 (Earthmoving machinery – Recyclability and recoverability – Terminology and calculation method), recyclability rate is defined as percentage by mass (mass fraction in percent) of the new machine potentially able to be recycled, reused, or both.

All parts in the bill of material are first evaluated by component type based on a list of components defined by the ISO 16714:2008 and Japan CEMA (Construction Equipment Manufacturers Association) standards. Remaining parts are further evaluated for recyclability based on material type.

Because of variations of product configurations, the following value in the table may vary.

Recyclability – 92%

# NOTES

# NOTES

# NOTES

For more complete information on Cat products, dealer services and industry solutions, visit us on the web at [www.cat.com](http://www.cat.com)

© 2025 Caterpillar. All Rights Reserved.

Materials and specifications are subject to change without notice. Featured machines in photos may include additional equipment. See your Cat dealer for available options.

CAT, CATERPILLAR, LET'S DO THE WORK, VisionLink™, their respective logos, "Caterpillar Corporate Yellow," the "Power Edge" and Cat "Modern Hex" trade dress as well as corporate and product identity used herein, are trademarks of Caterpillar and may not be used without permission.

[www.cat.com](http://www.cat.com) [www.caterpillar.com](http://www.caterpillar.com)

AEHQ8455-01 (09-2025)  
Replaces AEHQ8455-00  
Build Number: 07A  
(Europe)

