

Cat[®] Underground Mining Hard Rock Vehicles Product Line



R1300G

R1300G Underground Mining Loader

Engine Power @ 2,200 rpm – ISO 14396:2002		
Engine	117 kW	(157 hp)
Engine Model	Cat® 3306B DITA	
Tire Size	17.5 × R25	

Dimensions

Nominal Payload Capacity	6800 kg	(14,991 lb)
Gross Machine Operating Weight	29 702 kg	(65,482 lb)
Bucket Capacity (Standard)	3.1 m ³	(4.1 yd ³)
Bucket Width	2200 mm	(86.6 in)
Width (Overall Including Bucket)	2290 mm	(90.2 in)
Width (Overall Excluding Bucket)	2109 mm	(83 in)
Height (Overall)	2120 mm	(83.5 in)
Length (Tramming)	8714 mm	(343.1 in)
Outer Clearance Radius	5717 mm	(225.1 in)
Inner Clearance Radius	2825 mm	(111.2 in)
Hydraulic Cycle Time	Secs	
Raise	5.0	
Dump	2.0	
Lower	2.3	
Total	9.3	
Axle Oscillation	± 10°	
Articulation Angle	± 42.5°	
Ground Clearance	321 mm	(12.6 in)

Speeds Forward	km/h	(mph)
1st	4.5	(2.8)
2nd	7.8	(4.8)
3rd	15	(9.3)
4th	26.3	(16.3)

Speeds Reverse	km/h	(mph)
1st	4.5	(2.8)
2nd	7.8	(4.8)
3rd	14.8	(9.2)
4th	23	(14.3)

Fuel Capacities	Liters	US Gallons	Imperial Gallons
Fuel Tank	295	77.9	64.9

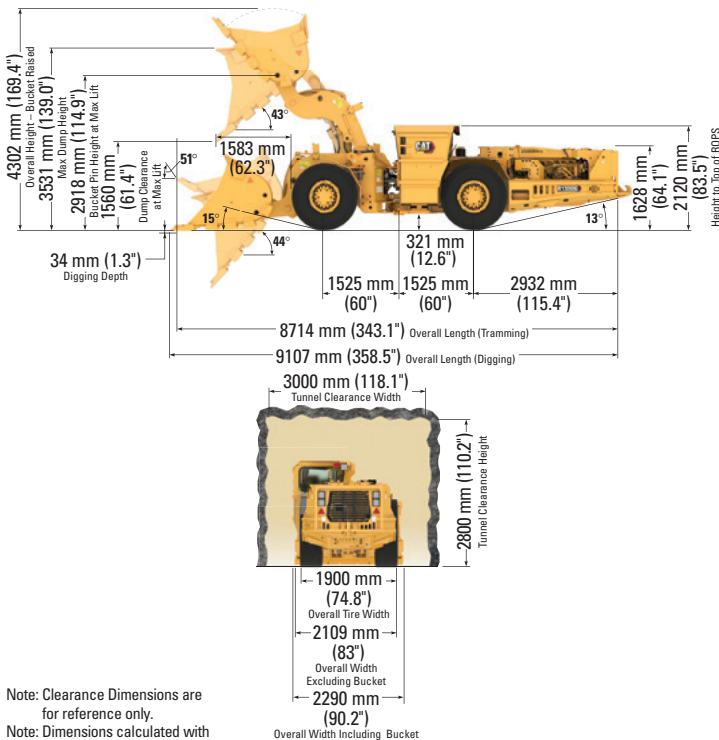

Note: Clearance Dimensions are for reference only.
Note: Dimensions calculated with Half Arrow Hardware.

R1600H

R1600H Underground Mining Loader

Engine Power @ 1,800 rpm – ISO 14396:2002		
VR Engine	202 kW	(271 hp)
Tier 3 Engine	202 kW	(271 hp)
Engine Model	Cat C11	
Tire Size	18.00 × R25	

Dimensions

Nominal Payload Capacity	10 200 kg	(22,487 lb)
Gross Machine Mass	44 204 kg	(97,453 lb)
Bucket Capacity (Standard)	4.8 m ³	(6.3 yd ³)
Bucket Width	2600 mm	(102.4 in)
Width (Overall Including Bucket)	2723 mm	(107.2 in)
Width (Overall Excluding Bucket)	2564 mm	(100.9 in)
Height (Overall)	2400 mm	(94.5 in)
Length (Tramming)	9711 mm	(382.3 in)
Outer Clearance Radius	6638 mm	(261.3 in)
Inner Clearance Radius	3291 mm	(129.6 in)
Hydraulic Cycle Time	Secs	
Raise	7.6	
Dump	1.6	
Lower	2.0	
Total	11.2	
Axle Oscillation	± 10°	
Articulation Angle	± 42.5°	
Ground Clearance	344 mm	(13.5 in)

Speeds Forward	km/h	(mph)
1st	4.5	(2.8)
2nd	9	(5.6)
3rd	16.8	(10.4)
4th	27.5	(17.1)

Speeds Reverse	km/h	(mph)
1st	5	(3.1)
2nd	11	(6.8)
3rd	19	(11.8)
4th	29.3	(18.2)

Fuel Capacities	Liters	US Gallons	Imperial Gallons
Fuel Tank	400	105.7	88.0
Secondary Fuel Tank (If Equipped)	330	87.2	72.6

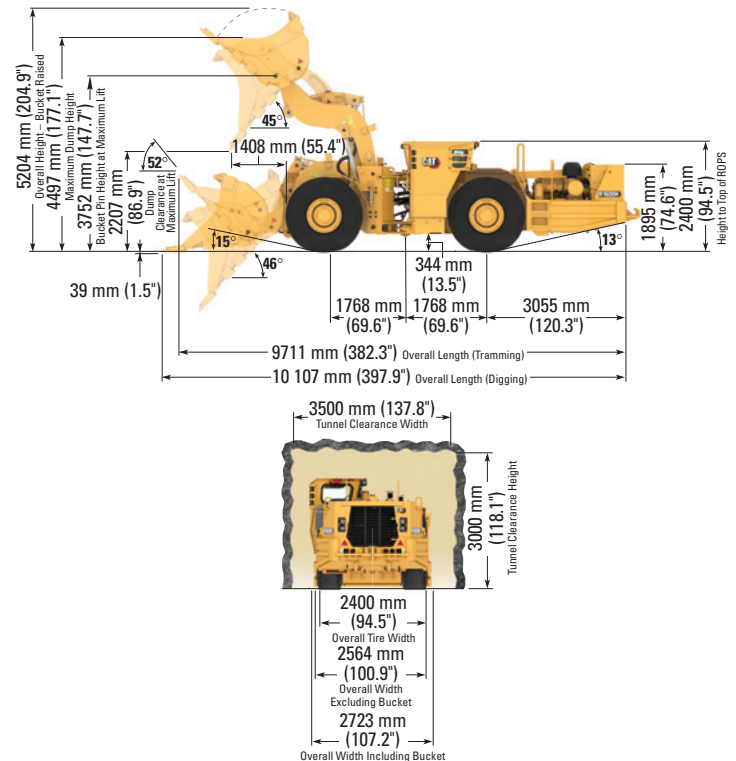

R1700 Underground Mining Loader

Engine Power @ 2,050 rpm – ISO 14396:2002		
EU Stage V Engine	257 kW	(345 hp)
Engine Power @ 1,800 rpm – ISO 14396:2002		
Tier 3 Engine	269 kW	(361 hp)
VR Engine	269 kW	(361 hp)
Engine Model	Cat C13	
Tire Size	26.5 × R25	

Dimensions

Nominal Payload Capacity – Trimming	15 000 kg	(33,069 lb)
Nominal Payload Capacity – Truck Loading	15 000 kg	(33,069 lb)
Gross Machine Mass	62 930 kg	(138,737 lb)
Bucket Capacity (Standard)	5.7 m ³	(7.5 yd ³)
Bucket Width	2830 mm	(111 in)
Width (Overall Including Bucket)	2860 mm	(113 in)
Width (Overall Excluding Bucket)	2727 mm	(107 in)
Height (Overall)	2541 mm	(100 in)
Length (Trimming)	10 806 mm	(425 in)
Outside Clearance Radius	6857 mm	(270 in)
Inside Clearance Radius	3139 mm	(123.5 in)
Hydraulic Cycle Time	Secs	
Raise	6.8	
Dump	3.3	
Lower	2.9	
Total	13.2	
Axle Oscillation	± 8°	
Articulation Angle	± 44°	
Ground Clearance	393 mm	(15 in)

Speeds Forward	km/h	(mph)
1st	4.9	(3)
2nd	9.2	(5.7)
3rd	16.4	(10.2)
4th	28.8	(17.9)

Speeds Reverse	km/h	(mph)
1st	5.9	(3.7)
2nd	10.5	(6.5)
3rd	18.7	(11.6)
4th	32.5	(20.2)

Fuel Capacities	Liters	US Gallons	Imperial Gallons
Fuel Tank (Bolt In)	486	128.4	106.9

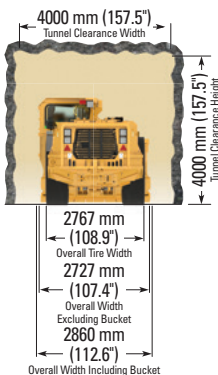
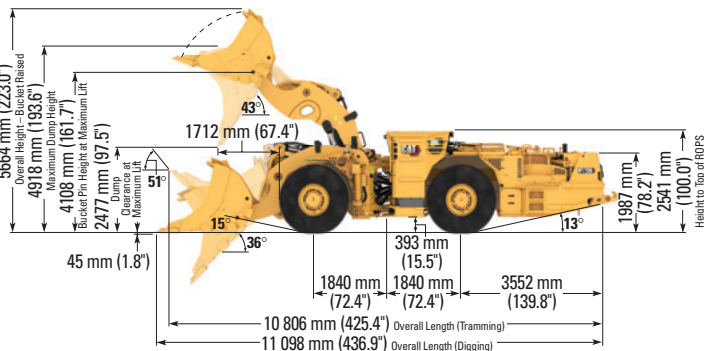

Note: Clearance Dimensions are for reference only.
Note: Dimensions calculated with Half Arrow Hardware.

R1700 XE Underground Mining Loader – Battery Electric

Traction Motor	Cat, Switched Reluctance
Rated Power – Peak	250 kW (335 hp)
Rated Power – Nominal	220 kW (295 hp)
Rated Torque (peak, nominal = @ 12 km/h (7.5 mph) and nominal power)	3200 N·m/660 N·m (2360 lbf·ft/443 lbf·ft)

Auxiliary Motor	Cat, Switched Reluctance
Rated Power (peak, nominal)	226 kW 303 hp
Rated Torque (peak, nominal = 1,600 equivalent rpm)	600 N·m/531 N·m (443 lbf·ft/392 lbf·ft)

Inverter Rating	350A (nominal DC), 715VDC
Battery Chemistry	Li-Ion
Charging Method	Ultra Fast Charge Onboard
Tire Size	26.5R25

Dimensions

Nominal Payload Capacity	15 000 kg	(33,069 lb)
Operating Mass	48 743 kg	(107,460 lb)
Bucket Capacity (Standard)	5.7 m ³	(7.5 yd ³)
Bucket Width	2830 mm	(111 in)
Width (Overall Including Bucket)	2923 mm	(115 in)
Width (Overall Excluding Bucket)	2729 mm	(107 in)
Height (Overall)	2541 mm	(100 in)
Length (Trimming)	10 855 mm	(427 in)
Outside Clearance Radius	6997 mm	(272 in)
Inside Clearance Radius	3189 mm	(124 in)
Hydraulic Cycle Time	Secs	
Raise	6.8	
Dump	3.3	
Lower	2.9	
Total	13.2	
Axle Oscillation	± 8°	
Articulation Angle	± 44°	
Ground Clearance	393 mm	(15 in)

Grade Performance

	25 Degree Ambient, 2% Rolling Resistance				
Grade (%)	0	5	10	15	20
Loaded – km/h (mph)	18 (11.2)	14.8 (9.2)	8.6 (5.3)	6.1 (3.8)	4.8 (3)
Unloaded – km/h (mph)	18 (11.2)	18 (11.2)	11.1 (6.9)	7.9 (4.9)	6.2 (3.9)

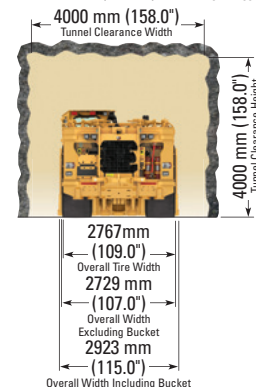
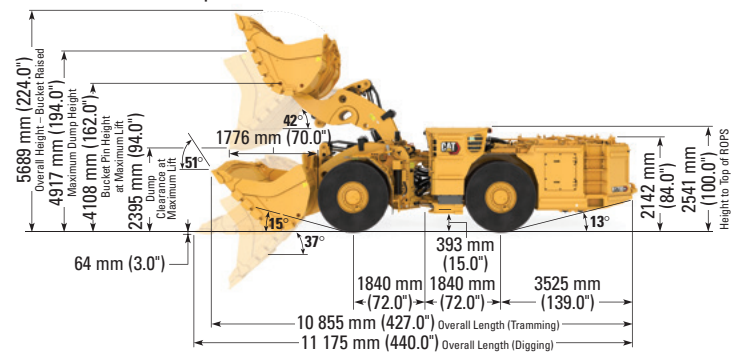

R2900G

R2900G Underground Mining Loader

Engine Power @ 1,800 rpm - ISO 14396:2002

VR Engine	299 kW	(401 hp)
Tier 3 Engine	299 kW	(401 hp)
Engine Model	Cat C15	
Tire Size	29.5 × R29	

Dimensions

Nominal Payload Capacity	17 200 kg	(37,920 lb)
Gross Machine Mass	73 451 kg	(161,932 lb)
Bucket Capacity (Standard)	7.2 m ³	(9.4 yd ³)
Bucket Width	3054 mm	(120.4 in)
Width (Overall Including Bucket)	3176 mm	(125.0 in)
Width (Overall Excluding Bucket)	3010 mm	(118.5 in)
Height (Overall)	2886 mm	(113.6 in)
Length (Tramming)	10 949 mm	(431.1 in)
Outer Clearance Radius	7323 mm	(288.3 in)
Inner Clearance Radius	3383 mm	(133.2 in)
Hydraulic Cycle Time	Secs	

Raise	9.2
Dump	3.4
Lower	3.1
Total	15.7

Axle Oscillation	± 8°
Articulation Angle	± 42.5°
Ground Clearance	465 mm (18.3 in)

Speeds Forward	km/h	(mph)
1st	5.1	(3.2)
2nd	9.7	(6.0)
3rd	17.3	(10.7)
4th	30.4	(18.9)

Speeds Reverse	km/h	(mph)
1st	6.6	(4.1)
2nd	12.0	(7.5)
3rd	21.5	(13.4)
4th	32.8	(20.4)

Fuel Capacities	Liters	US Gallons	Imperial Gallons
Fuel Tank (Dual)	1425	376.4	313.5

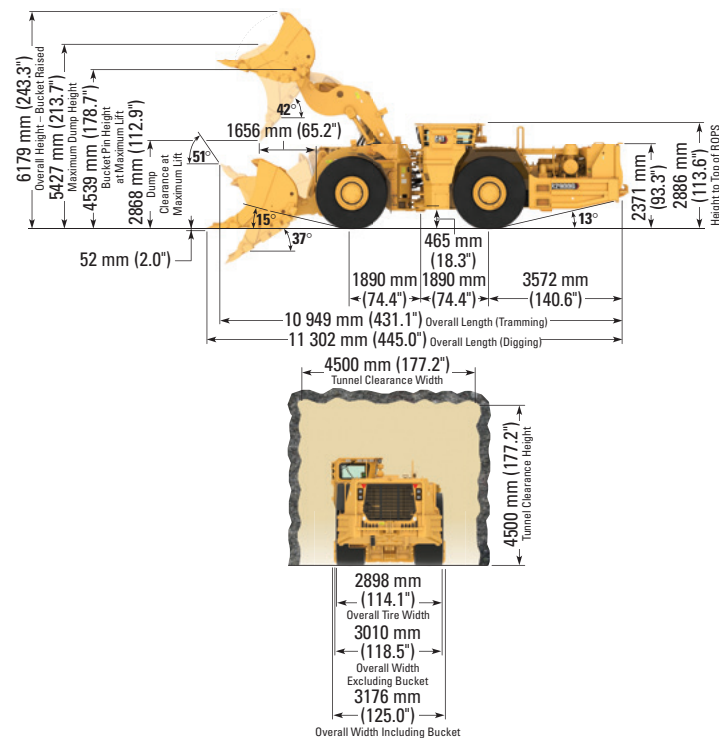

R2900 XE

R2900 XE Underground Mining Loader – Diesel Electric

Engine Power @ 1,600 rpm

Stage V Engine – ISO 14396:2002	335 kW	(449 hp)
Tier 2/Stage II Engine – ISO 14396:2002	333 kW	(447 hp)
Engine Model	Cat C15	
Transmission Type	Cat switched reluctance electric drive	

Tire Size	29.5 × R29
-----------	------------

Dimensions

Nominal Payload Capacity	18 500 kg	(40,785 lb)
Gross Machine Mass	78 089 kg	(172,157 lb)
Bucket Capacity (Standard)	7.4 m ³	(9.7 yd ³)
Bucket Width	3054 mm	(120 in)
Width (Overall Including Bucket)	3090 mm	(122 in)
Width (Overall Excluding Bucket)	3028 mm	(119 in)
Height (Overall)	2860 mm	(113 in)
Length (Tramming)	11 033 mm	(434 in)
Outside Clearance Radius	7270 mm	(286 in)
Inside Clearance Radius	3391 mm	(134 in)
Hydraulic Cycle Time	Secs	

Raise	9
Dump	2.8
Lower	3.5
Total	15.3

Axle Oscillation	± 8°
Articulation Angle	± 42.5°
Ground Clearance	405 mm (16 in)

Speeds Forward (virtual)	km/h	(mph)
1st	5.8	(3.6)
2nd	9.5	(5.9)
3rd	17	(10.6)
4th	24.6	(15.3)
5th	33.4	(20.8)

Speeds Reverse (virtual)	km/h	(mph)
1st	6	(3.7)
2nd	10.1	(6.3)
3rd	18	(11.3)
4th	26	(16.2)
5th	32.9	(20.4)

Fuel Capacities	Liters	US Gallons	Imperial Gallons
Fuel Tank (Bolt In)	660	174.4	---

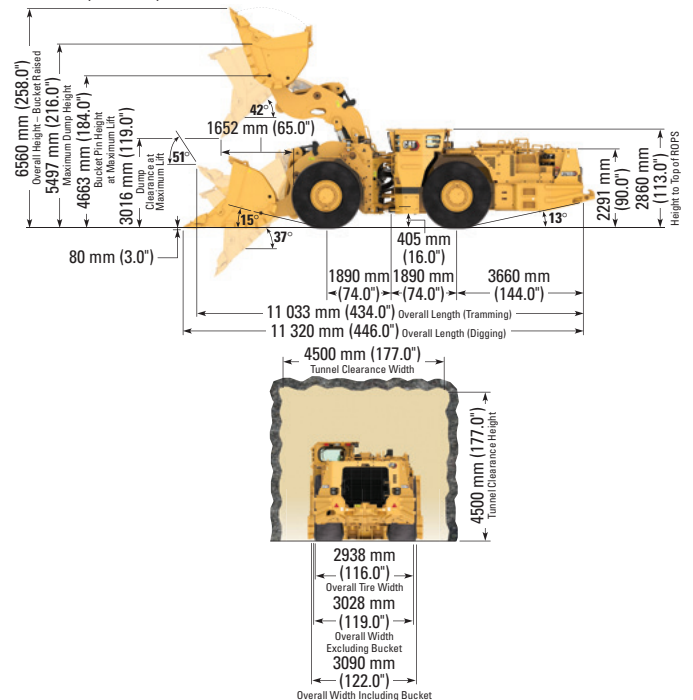

R3000H

R3000H Underground Mining Loader

Engine Power @ 1,800 rpm – ISO 14396:2002

VR Engine	299 kW	(401 hp)
Tier 3 Engine	299 kW	(401 hp)
Engine Model	Cat C15	
Tire Size	35/65 R33	

Dimensions

Nominal Payload Capacity	20 000 kg	(44,092 lb)
Gross Machine Mass	82 000 kg	(180,779 lb)
Bucket Capacity (Standard)	8.9 m ³	(11.6 yd ³)
Bucket Width	3354 mm	(132.0 in)
Width (Overall Including Bucket)	3454 mm	(136.0 in)
Width (Overall Excluding Bucket)	3200 mm	(126.0 in)
Height (Overall)	3002 mm	(118.2 in)
Length (Tramming)	11 150 mm	(439.0 in)
Outside Clearance Radius	7536 mm	(296.7 in)
Inside Clearance Radius	3247 mm	(127.8 in)
Hydraulic Cycle Time	Secs	
Raise	8.8	
Dump	1.85	
Lower	3.54	
Total	14.2	
Axle Oscillation	± 8°	
Articulation Angle	± 42.5°	
Ground Clearance	476 mm	(18.7 in)

Speeds Forward	km/h	(mph)
1st	4.9	(3)
2nd	9.1	(5.7)
3rd	16.4	(10.2)
4th	28.2	(17.5)

Speeds Reverse		
1st	6.6	(4.1)
2nd	11.5	(7.1)
3rd	20.5	(12.7)
4th	31.3	(19.4)

Fuel Capacities	Liters	US Gallons	Imperial Gallons
Fuel Tank (Dual)	1539	406.5	338.5

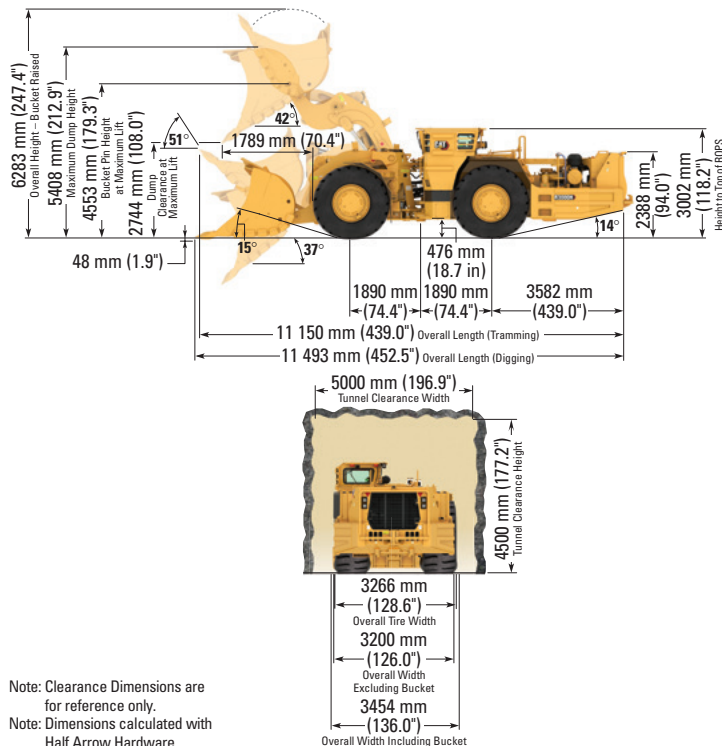

Note: Clearance Dimensions are for reference only.
Note: Dimensions calculated with Half Arrow Hardware.

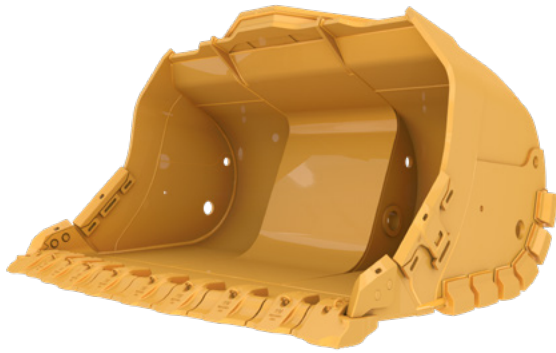

Bucket Capacities

	Size		Width	
	m ³	(yd ³)	mm	(inch)
R1300G				
513-7350	2.5	(3.3)	2010	(79.1)
186-9278	2.8	(3.7)	2010	(79.1)
243-6143 (STD)	3.1	(4.1)	2200	(86.6)
243-6224	3.4	(4.4)	2400	(94.5)
157-3624 (EB)	2.4	(3.1)	2200	(86.6)
R1600H				
514-5710	4.2	(5.5)	2600	(102.4)
203-1792 (STD)	4.8	(6.3)	2600	(102.4)
227-4704	5.6	(7.3)	2600	(102.4)
514-5720	5.9	(7.7)	2900	(114.2)
260-5198 (EB)	4.8	(6.3)	2600	(102.4)
598-8733 (BTB)	5.3	(6.9)	2932	(115.4)
R1700				
467-1827 (STD)	5.7	(7.5)	2840	(112)
467-1828	6.1	(8.0)	2982	(117)
467-1829	6.6	(8.6)	2932	(115)
616-0585	7.2	(9.4)	2932	(115)
467-1830	7.5	(9.8)	3254	(128)
549-5378	8.0	(10.5)	3354	(132)
467-1831 (LM)	8.6	(11.2)	3492	(137)
566-6471 (EB)	5.8	(7.6)	2780	(109)
561-1775 (BTB)	6.8	(8.9)	2962	(117)
581-6671 (BTB)	7.5	(9.8)	3376	(133)
R1700 XE				
467-1827 (STD)	5.7	(7.5)	2840	(112)
467-1828	6.1	(8.0)	2982	(117)
467-1829	6.6	(8.6)	2932	(115)
467-1830	7.5	(9.8)	3254	(128)
561-1775 (BTB)	6.8	(8.9)	2962	(117)
R2900G				
303-8806	6.3	(8.2)	3054	(120.2)
249-4899 (STD)	7.2	(9.4)	3054	(120.2)
249-4892	8.3	(10.9)	3154	(124.2)
249-4893	8.9	(11.6)	3354	(132.0)
R2900 XE				
638-3510 (STD)	7.4	9.7	3054	(120)
638-3511	8.6	11.2	3154	(124)
638-3512	9.2	12	3354	(132)
638-3513	9.8	12.8	3454	(136)
R3000H				
356-1320 (STD)	8.9	(11.6)	3354	(132.0)
524-6458	9.5	(12.4)	3476	(136.9)
372-1680	10.5	(13.7)	3454	(136.0)
372-1695 (LM)	11.6	(15.2)	3754	(147.8)

(STD) Standard Bucket
 (EB) Ejector Bucket
 (LM) Light Material Bucket
 (BTB) Bolt-Together Bucket

Ground Engaging Tools (GET) Options

Cat Modular Segment Welded GET System

Individual segments are configured to form Lip Assemblies that cover all LHD size classes. Modular Shrouds deliver welded part reliability with the replacement simplicity of a mechanical system. Wear indicators are visible from the topside to help establish maintenance intervals.

Available for all LHD models, on all bucket sizes.

Cat Bolt-On Half-Arrow (BOHA) GET

The bolt-on half arrow (BOHA) system delivers best-in-class lip protection with fewer parts than competitive systems. Reducing maintenance cost through better protection, and fewer parts to manage. BOHA segments have superior hardness vs. welded components.

Available for all LHD models, on all bucket sizes.

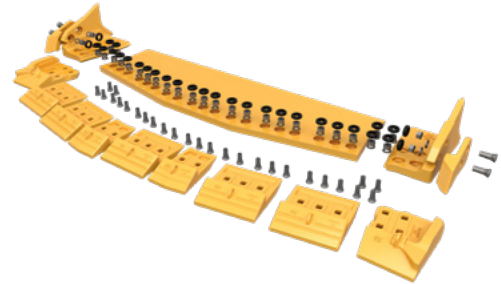

Cat Durilock™ Shroud System With Cat Infinite™ Retention

The Cat Durilock™ Shrouds adapt to your ever-changing mining environment in minutes without having to change the base edge or retention system. Infinite™ secures the three shroud systems for maintenance free retention.

Available for R1700, R2900G, R2900 XE and R3000H LHDs, on all dump bucket and bolt-together bucket sizes.



For more information, please refer to
 Cat® Mining Ground Engaging Tools Product Catalog – PEBJ0030
 Cat® Mining Ground Engaging Tools Parts Catalog – PEBJ0031

MEC500 Mobile Equipment Charger

Weights

MEC500	1656 kg	(3,650 lb)
MEC500 with Optional Skid (pictured below)	2037 kg	(4,490 lb)

Electrical Specifications

Rated Power (AC Input)	500 kW
Rated Current (DC Output)	700 Amps
Voltage Range	400-660 VAC
Voltage Output	300-1,000 VAC
Frequency Range	45-65 Hz
Input Supply (AC Input)	3-Phase Insulated Terra (IT)
Cable Output	
Cat Proprietary Connector	700 Amp



Cat® MineStar™ is the mining industry’s most comprehensive and thoroughly integrated suite of technology offerings. MineStar has been delivering results for many years and is proven on mine sites around the world—the majority of them surface operations. As more miners pivot from open pit to underground mines, Caterpillar has expanded our technology portfolio to ensure we’re able to support them just as we’ve done on the surface for decades. No matter the size, type or complexity of your underground operation, Cat MineStar can help you deal with the challenges you face every day: Controlling costs. Extending equipment life. Working more productively. And keeping people safe.

Cat MineStar Solutions have the ability to track, monitor, automate and manage all types of assets—from people to production machines to light vehicles on site. Offerings can be deployed individually or integrated to create a comprehensive technology system that is scalable and configurable to the needs of your operation. And they work with any brand of equipment, sharing data across existing machines, systems and technologies. We’ll work alongside you to develop a customized technology roadmap, helping you with the change management that is key to the successful adoption of technology. Whether you integrate a single technology or a multi-purpose solution, you can expect a safer, more productive and more efficient operation.

For more information visit: <https://www.cat.com/minestar>

LOADER STANDARD EQUIPMENT

ELECTRICAL

- Alternator
- Auxiliary battery receptacle
- Battery disconnect switch, ground level
- Diagnostic connector
- Electric starting, 24V
- Engine shutdown switch
- External lighting, front, rear (halogen or LED depending on selected model)
- Low maintenance batteries
- Reversing alarm
- Starting and charging system

OPERATOR ENVIRONMENT

- Cat Electronic Monitoring System (Cat EMS)
- Electric horns
- Gauges
 - Engine coolant temperature
 - Hydraulic oil temperature
 - Fuel level
 - Speedometer
 - Tachometer
- Indicator lights
- Open operator station (ROPS/FOPS) structure (except R2900 XE and R3000H)
- Operator presence system (except on R1300G)
- Suspension seat with retractable seat belt (depends on selected model)
- Hydraulic implement controls, single joystick
- Pilot hydraulic implement controls (single joystick)
- Stic Steering

POWER TRAIN

- Cat engine (model varies depending on selected loader)
- Engine air intake pre-cleaner
- Electric fuel priming pump (except R1300G)
- Long life coolant
- Planetary auto shift transmission
- Radiator, cross flow
- SAFR™ full hydraulic enclosed wet, multiple-disc brakes, oil-cooled
- Transmission neutralizer
- Torque converter
- Traction Control (R1700 and R2900 XE)
- Electric drive with automatic generator (R2900 XE)
- Single electric drive motor (R2900 XE)

OTHER STANDARD EQUIPMENT

- Brake lights
- Bucket, dump (size varies depending on selected loader)
- Bucket positioner, return to dig (optional on R1300G)
- Catalytic exhaust purifier/muffler group
- Decals, international pictographics
- Engine and transmission belly guards
- Fenders, front, rear
- Fire wall
- Fuel system manual shut off tap
- Handholds
- Operator and maintenance manual, English and other applicable local languages to select
- Protective wear bars
- S-O-SSM port
 - Coolant
 - Engine oil
 - Hydraulic oil
 - Transmission oil
- Swing out radiator grill
- Ventilated hood and covers
- Tires and rims: A tire must be selected from the mandatory attachments section of the machine price list. Base machine price includes a standard tubeless rim allowance only.

NOTE: Additional equipment may be standard on selected models. Consult model specalog for more information.

For R1700 XE battery electric loader standard and optional equipment, please refer to R1700 XE technical specification AEXQ3328.

LOADER OPTIONAL EQUIPMENT

- Battery and engine shutdown switch
 - Ground level isolation, in cab isolation switch
 - Ground level isolation, engine shutdown switch
 - Ground level isolation, in cab isolation, engine shutdown switch
- Brake pressure gauges
- Brake release arrangements
 - Recovery hook
 - Recovery bar
- Buckets
 - Cutting edge, Modular Weld-on Half-Arrow (MWOHA)
 - Cutting edge, Bolt-On Half-Arrow (BOHA)
 - Cutting edge, Cat Durilock™ Shroud System
 - Mechanical Attached Shroud (MAS)
 - Mechanically Attached Wear Plate System (MAWPS)
 - Heel shrouds
 - Dump, Ejector, Bolt-together and Light Material buckets.
 - Lip fully welded or tack welded
 - Wear bars
 - Wear liner
- Cover, anti vandalism for shipping
- Drawbar attachment, bolt-on
- Dual fuel tanks (selected models only)
- Engine options (except R1300G)
 - Engine, Ventilation Reduction (VR)
 - Engine, Tier 3
 - Engine, EU Stage V (R1700 and R2900 XE)
- Fast fill system
 - Coolant
 - Engine oil
 - Fuel (single or dual tanks)
 - Hydraulic oil
 - Transmission oil
- Fire suppression system
 - Ansul
 - Foam, water based
- Fluids
 - Arctic fuel
 - Arctic coolant
- Guard, rear side quarter window
- Handrails, fold down
- Hydraulic system
 - Ejector bucket ready
 - Alternate implement/pilot control configuration
- Idle timer (standard on R2900 XE)
- Lighting
 - External lighting system, front, rear, LED work lights
- Lubrication system
 - Automatic
 - Centralized
- Mine transfer
 - Mine transfer ready rear frame (tack welded)
 - Lifting group, mine transfer
- Operator station ROPS/FOPS enclosed (standard on R2900 XE and R3000H)
 - Air conditioning and heater
 - Cab pressurizer and filter
 - Dome light
 - Radio ready compartment for radio and speakers
- Park brake switch engagement
 - Push to apply
 - Pull to apply
- Payload monitoring system
- Reflective tape
- Remote control interface (excludes transmitter and receiver)
- Reversible steering
- Ride control system
- Rim
 - Tube type
 - Spare (tube or tubeless)
 - Rim identification numbering
- Seat covers
 - Tee and standard
- Secondary steering system
- Technology
 - Cat® MineStar™ – Fleet, Detect, Health and Command
 - Vital Information Management System (VIMS) Gen 3 (except R1600H, R1700, R2900 XE and R3000H, which have Product Link™ system as standard)
- Tee seat
- Tire arrangements
 - Bridgestone VSMS2–VMDL–VSDL
- Wear protection bars
 - Cab/ROPS
 - Hydraulic tank
 - Radiator
- Windows
 - Single pane
 - Dual pane

NOTE: Not all features are available in all regions and models. See your Cat dealer for more information.

AD30 Underground Mining Truck

Engine Power @ 1,800 rpm – ISO 14396:2002			
VR Engine	299 kW	(401 hp)	
Tier 3 Engine	299 kW	(401 hp)	
Engine Model	Cat C15		
Tire Size	26.5 × R25		

Dimensions

Nominal Payload Capacity (Dump Body)	30 000 kg	(66,138 lb)
Nominal Payload Capacity (Ejector Body)	27 000 kg	(59,525 lb)
Gross Machine Mass	60 000 kg	(132,277 lb)
Body Capacity (Standard)	14.4 m ³	(18.8 yd ³)
Width (Overall)	2690 mm	(105.9 in)
Height (Overall)	2600 mm	(102.4 in)
Length (Overall)	10 153 mm	(399.7 in)
Dump Height	5602 mm	(220.6 in)
Outside Clearance Radius	8571 mm	(337.4 in)
Inside Clearance Radius	5030 mm	(198.0 in)
Hydraulic Cycle Time	Secs	
Raise	10.5	
Lower	11.2	
Total	21.7	
Axle Oscillation	± 10°	
Articulation Angle	± 42.5°	
Ground Clearance	400 mm	(15.7 in)
Speeds Forward	km/h	(mph)
1st	6.3	(3.9)
2nd	11.3	(7.0)
3rd	20.8	(12.9)
4th	36.7	(22.8)
Speeds Reverse		
1st	7.1	(4.4)

Fuel Capacities	Liters	US Gallons	Imperial Gallons
Fuel Tank	410	108	90

AD45 Underground Mining Truck

Engine Power @ 2,000 rpm – ISO 14396:2002			
EU Stage V Engine	446 kW	(598 hp)	
VR Engine	433 kW	(581 hp)	
Tier 3/Stage IIIA Equivalent Engine	433 kW	(581 hp)	
Engine Model	Cat C18		
Tire Size	29.5 × R29		

Dimensions

Nominal Payload Capacity	45 000 kg	(99,208 lb)
Gross Machine Mass	88 820 kg	(195,815 lb)
Body Capacity (Standard)	21.3 m ³	(27.9 yd ³)
Width (Overall)	3020 mm	(118.9 in)
Height (Overall)	3035 mm	(119.5 in)
Length (Overall)	11 196 mm	(440.8 in)
Dump Height	6361 mm	(250.4 in)
Outside Clearance Radius	9420 mm	(371.0 in)
Inside Clearance Radius	5310 mm	(209.0 in)
Body Hoist (Stage V Engine Model)	Secs	
Raise	15	
Lower	21	
Total	36	
Body Hoist (Other Engine Models)	Secs	
Raise	14	
Lower	21	
Total	35	
Axle Oscillation	± 10°	
Articulation Angle	± 42.5°	
Ground Clearance	441 mm	(17.4 in)
Speeds Forward	km/h	(mph)
1st	7	(4.4)
2nd	9.5	(5.9)
3rd	12.9	(8.0)
4th	17.3	(10.8)
5th	23.5	(14.6)
6th	31.7	(19.7)
7th	42.4	(26.4)
Speeds Reverse		
1st	6.8	(4.2)
2nd	9	(5.6)

Fuel Capacities	Liters	US Gallons	Imperial Gallons
Fuel Tank	764	201.8	168.1

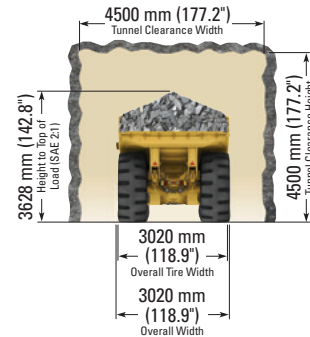
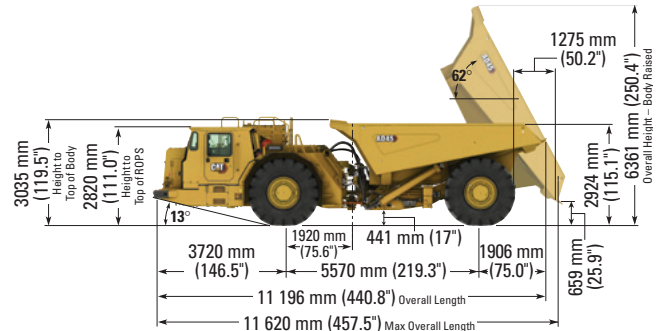
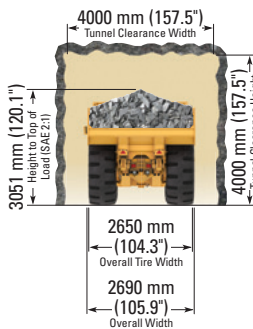
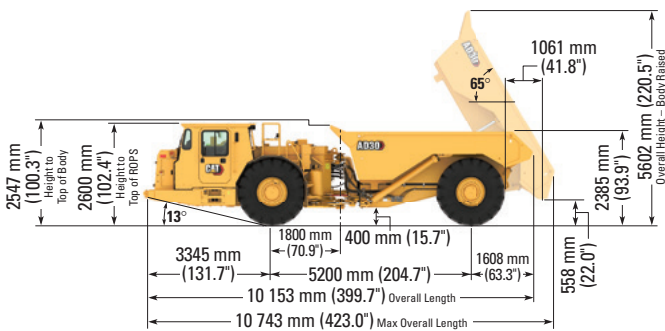

Note: Clearance Dimensions are for reference only.

AD63 Underground Mining Truck

Engine Power @ 1,800 rpm – ISO 14396:2002
 Stage V Engine 593 kW (795 hp)
 Engine Model Cat C27
 Tire Size 35 × 65 R33

Dimensions

Nominal Payload Capacity	63 000 kg	(138,891 lb)
Gross Machine Mass	118 940 kg	(262,218 lb)
Body Capacity (Standard)	26.9 m ³	(35.2 yd ³)
Width (Overall)	3346 mm	(132.0 in)
Height (Overall)	3202 mm	(126.0 in)
Length (Overall)	12 040 mm	(474.0 in)
Dump Height	6969 mm	(274.0 in)
Outside Clearance Radius	10 005 mm	(393.9 in)
Inside Clearance Radius	5540 mm	(218.1 in)
Body Hoist	Secs	
Raise	13	
Lower	24	
Total	37	
Axle Oscillation	± 10°	
Articulation Angle	± 42.5°	
Ground Clearance	393 mm	(15.5 in)
Speeds Forward	km/h	(mph)
1st	6.5	(4.1)
2nd	9.2	(5.7)
3rd	12.4	(7.7)
4th	16.6	(10.3)
5th	22.5	(14.0)
6th	30.3	(18.9)
7th	41.0	(25.5)
Speeds Reverse		
1st	8.6	(5.3)

Fuel Capacities	Liters	US Gallons	Imperial Gallons
Fuel Tank	900	237.7	--



Body Capacities

All Capacities = (SAE 2:1)		Size	Width		Height	
Model	m ³	(yd ³)	mm	(inch)	mm	(inch)
AD30						
613-7031	11.3	(14.8)	2690	(105.9)	2285	(90.0)
613-7034 (STD)	14.4	(18.8)	2690	(105.9)	2385	(93.9)
613-7037 (WB)	16.8	(21.9)	3040	(119.7)	2295	(90.4)
613-7036	17.5	(22.9)	2840	(111.8)	2560	(100.8)
613-7027 (EB) ¹	15.2	(19.9)	2898	(114.1)	2616	(103.0)
613-7029 (EB) ²	16.8	(21.9)	2898	(114.1)	2791	(109.9)
AD45						
568-7264	18.0	(23.5)	3000	(118.1)	2720	(107.1)
568-7256 (STD)	21.3	(27.9)	3000	(118.1)	2925	(115.2)
568-7260	25.1	(32.8)	3200	(126.0)	3070	(120.9)
568-7265 (EB) ³	22.9	(29.9)	3200	(126.0)	3177	(125.1)
AD63						
592-0787 (STD)	26.9	(35.2)	3290	(129.5)	3045	(119.9)
592-0789	32.6	(42.6)	3480	(137.0)	3326	(130.9)
592-0790	33.8	(44.2)	3480	(137.0)	3426	(134.9)
592-0791	36.6	(47.9)	3480	(137.0)	3473	(136.7)
588-8056 (LM)	38.3	(50.1)	3500	(138.0)	3473	(136.7)

(STD) Standard Body
 (WB) Wide Body
 (EB) Ejector Body
 (LM) Light Material Body
¹613-7028 in the U.S.
²613-7030 in the U.S.
³568-7266 in the U.S.

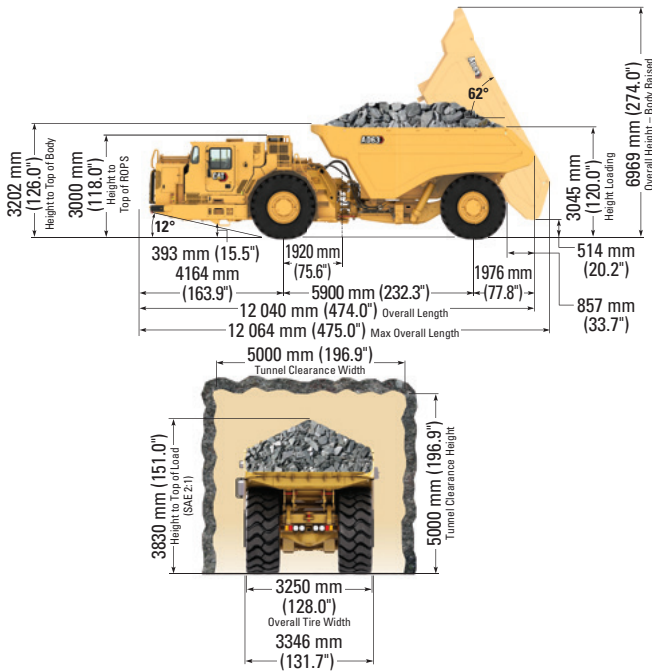

TRUCK STANDARD EQUIPMENT

ELECTRICAL

- 12V power supply in cab
- Alternator
- Auxiliary battery receptacle
- Battery disconnect switch, ground level
- Circuit breaker, 80-amp
- Diagnostic connector
- Electric starting, 24V
- Engine shutdown switch, ground level
- Lighting (halogen or LED on selected models)
 - Brake and tail light, LED
 - Headlights with dimmer switch
 - Rear work light (cab mounted)
 - Reversing lights
- Low maintenance batteries
- Reversing alarm
- Starting and charging system

OPERATOR ENVIRONMENT

- Cat Electronic Monitoring System (Cat EMS)
- Electric horns
- Gauges
 - Engine coolant temperature
 - Transmission coolant temperature
 - Hydraulic oil temperature
 - Fuel level
 - Speedometer
 - Tachometer
- Indicator lights
 - Alert warning light
 - Body up position warning
 - Brake drag indicator
 - High beam
 - Residual brake pressure warning
 - Retarder application
 - Turn signal
- Low hydraulic level warning
- Open operator station ROPS/FOPS structure (except AD63)
- Operator presence system (auto park brake)
- Rearview mirrors
- Tilt/telescopic steering wheel (tilt only on AD22)
- Suspension seat Cat Comfort TLV2 with retractable seat belt
- Trainer/passenger seat and seat belt
- Turn signal indicators (AD45 and AD63)

POWER TRAIN

- Cat engine (model varies depending on selected truck)
- Automatic brake retarder control (manual on AD22)
- Auto shift transmission
- Electric fuel priming pump (manual on AD22)
- Exhaust, turbo compartment shielding
- Four wheel drive
- Long life coolant
- Programmable ground speed limiting
- Programmable gear block out with tray up
- Radiator cap manual release
- Radiator, cross flow
- SAFR full hydraulic enclosed wet, multiple-disc brakes, oil-cooled
- Torque converter, standard with automatic lockup

OTHER STANDARD EQUIPMENT

- Body, Dump (size varies depending on selected truck)
- Catalytic exhaust purifier/muffler group
- Centralized lubrication points
- Decals, international pictographics
- Dual fuel tank (AD45 and AD63 only)
- Engine and transmission belly guards
- Fenders, front, rear flaps
- Fire wall
- Front axle suspension (AD45 and AD63 only)
- Frame lifting lugs
- Front and rear tow pin
- Front rubber bumpers (AD45 and AD63 only)
- Fuel system manual shut off tap
- Hand hold (access on/off top deck)
- Hitch, articulated and oscillated
- Operator and maintenance manual, English and other applicable local languages to select
- Secondary steering system (AD63 only)
- S-O-S port
 - Coolant
 - Engine oil
 - Hydraulic oil
 - Transmission oil
- Swing out radiator grill
- Ventilated hood and covers
- Tires and rims: A tire must be selected from the mandatory attachments section of the machine price list. Base machine price includes a standard tubeless rim allowance only.

NOTE: Additional equipment may be standard on selected models. Consult model specalog for more information.

TRUCK OPTIONAL EQUIPMENT

- Battery shutdown
 - Ground level isolation, in cab isolation switch
 - Ground level isolation, engine shutdown switch
 - Ground level isolation, in cab isolation, engine shutdown switch
- Body
 - Dump
 - Ejector (except AD63)
- Body liners
- Brake pressure gauges
- Camera, color rear facing
- Cover, anti vandalism for shipping
- Engine options
 - Diesel particulate filter (for use with VR engine only)
 - Engine, Ventilation Reduction (VR) (except AD63)
 - Tier 3 (except AD63)
 - EU Stage V engine (optional on AD45 and standard on AD63)
- Fast fill system
 - Coolant
 - Engine oil
 - Fuel
 - Hydraulic oil
 - Transmission oil
- Fire suppression system
 - Foam, water based
- Fluids
 - Arctic fuel
 - Arctic coolant
- Lighting
 - Headlights with dimmer switch, LED
 - Rear work light (cab mounted), LED
 - Reversing lights, LED
- Lubrication system
 - Automatic, dump or ejector body
 - Centralized, ejector body
- Mine transfer
 - Mine transfer ready front frame (tack welded)
 - Mine transfer ready dump body (tack welded)
 - Mine transfer ready ejector body (tack welded)
- Operator station ROPS/FOPS enclosed (standard on AD63)
 - Air conditioning
 - Cab pressurizer and filter
 - Dome light
 - Heater
 - Radio ready compartment for radio and speakers
 - Sun visor
 - Window, sliding cab door
- Park brake switch engagement
 - Push to apply
 - Pull to apply
- Payload
 - Truck Payload Measurement System (TPMS)
 - Remote display for TPMS
- Reflective tape
- Rims
 - Rim identification numbering
 - Spare, tubeless
- Seat
 - Suspension seat Cat Comfort TLV2, vinyl
 - Suspension seat tee, mechanical
 - Cat Advanced Ride Management (ARM) seat with four point seatbelt harness (AD63)
- Seat cover
 - Tee and Cat Comfort TLV2
 - Seat cover, companion
- Secondary steering system
- Switches
 - Engine shutdown, fire suppression activation
 - Idle timer
 - Engine shutdown, fire suppression activation/idle timer
- Technology
 - Cat[®] MineStar™ -- Fleet, Detect, Health and Command
 - Vital Information Management System (VIMS) Gen 3 (except AD45 and AD63, which have Product Link™ system as standard)
- Tire arrangements
 - Tire Bridgestone VSNT – VSDL

NOTE: Not all features are available in all regions and models. See your Cat dealer for more information.

MODEL VS DRIVE SIZES



R1300G	R1600H	R1700	R1700 XE	R2900G	R2900 XE	R3000H
3.0 w × 2.8 h	3.5 w × 3.0 h	4.0 w × 4.0 h	4.0 w × 4.0 h	4.5 w × 4.5 h	4.5 w × 4.5 h	5.0 w × 4.5 h
3306B @	C11 @	C13 @	Battery Electric	C15 @	C15 @	C15 @
117 kW (157 hp)	202 kW (271 hp)	257 kW (345 hp)	15 000 kg (33,069 lb)	299 kW (401 hp)	335 kW (449 hp)	299 kW (401 hp)
6800 kg (14,991 lb)	10 200 kg (22,487 lb)	15 000 kg (33,069 lb)		17 200 kg (37,920 lb)	18 500 kg (40,785 lb)	20 000 kg (44,092 lb)



	AD30	AD45	AD63
	4.0w × 4.0h	4.5w × 4.5h	5.0w × 5.0h
	C15 @	C18 @	C27 @
	299 kW (401 hp)	446 kW (598 hp)	593 kW (795 hp)
Dump Body	30 000 kg (66,138 lb)	45 000 kg (99,208 lb)	63 000 kg (138,891 lb)
Ejector Body	27 000 kg (59,525 lb)	40 000 kg (88,185 lb)	

PASS MATCH TABLE

	R1300G	R1600H	R1700 / R1700 XE	R2900 / R2900 XE	R3000H
AD30	5 Pass	3 Pass			
AD45		4/5 Pass	3 Pass	3 Pass	
AD63				3/4 Pass	3 Pass

Guide to Pass Match

- Pass match table is based on standard bucket and body.
- Bucket and body sizes will change match pass figures.
- Bucket and body sizes should be matched to material weight.
- Actual pass match will vary depending on the density and the swell factor.
- Rear loading will depend on bucket and body widths. Recommendation is side loading.

Technical Specification References

Loaders

R1300G – AEXQ3477

R1600H – AEXQ3521

R1700 – AEXQ3514

R2900G – AEXQ3471

R2900 XE – AEXQ3327

R3000H – AEXQ3478

R1700 XE and MEC500 – AEXQ3328

Trucks

AD30 – AEXQ3472

AD45 – AEXQ3473

AD63 – AEXQ3458

Ground Engaging Tools

Cat® Mining Ground Engaging Tools Product Catalog – PEBJ0030

Cat® Mining Ground Engaging Tools Parts Catalog – PEBJ0031

For more complete information on Cat products, dealer services, and industry solutions, visit us on the web at www.cat.com

AECQ1050-10

© 2024 Caterpillar
All Rights Reserved
Printed in U.S.A.

Materials and specifications are subject to change without notice.
Featured machines in photos may include additional equipment.
See your Caterpillar dealer for available options.

CAT, CATERPILLAR, LET'S DO THE WORK, their respective logos, "Caterpillar Corporate Yellow," the "Power Edge" and Cat "Modern Hex" trade dress as well as corporate and product identity used herein, are trademarks of Caterpillar and may not be used without permission.

