

Operation and Maintenance Manual

**403J-E17T, 404J-E22T, and 404J-E22TA
Industrial Engines**

Important Safety Information

Most accidents that involve product operation, maintenance and repair are caused by failure to observe basic safety rules or precautions. An accident can often be avoided by recognizing potentially hazardous situations before an accident occurs. A person must be alert to potential hazards. This person should also have the necessary training, skills and tools to perform these functions correctly.

Incorrect operation, lubrication, maintenance or repair of this product can be dangerous and could result in injury or death.

Do not operate or perform any lubrication, maintenance or repair on this product, until you have read and understood the operation, lubrication, maintenance and repair information.

Safety precautions and warnings are provided in this manual and on the product. If these hazard warnings are not heeded, bodily injury or death could occur to you or to other persons.

The hazards are identified by the "Safety Alert Symbol" and followed by a "Signal Word" such as "DANGER", "WARNING" or "CAUTION". The Safety Alert "WARNING" label is shown below.



The meaning of this safety alert symbol is as follows:

Attention! Become Alert! Your Safety is Involved.

The message that appears under the warning explains the hazard and can be either written or pictorially presented.

Operations that may cause product damage are identified by "NOTICE" labels on the product and in this publication.

Perkins cannot anticipate every possible circumstance that might involve a potential hazard. The warnings in this publication and on the product are, therefore, not all inclusive. You must not use this product in any manner different from that considered by this manual without first satisfying yourself that you have considered all safety rules and precautions applicable to the operation of the product in the location of use, including site-specific rules and precautions applicable to the worksite. If a tool, procedure, work method or operating technique that is not specifically recommended by Perkins is used, you must satisfy yourself that it is safe for you and for others. You should also ensure that you are authorized to perform this work, and that the product will not be damaged or become unsafe by the operation, lubrication, maintenance or repair procedures that you intend to use.

The information, specifications, and illustrations in this publication are on the basis of information that was available at the time that the publication was written. The specifications, torques, pressures, measurements, adjustments, illustrations, and other items can change at any time. These changes can affect the service that is given to the product. Obtain the complete and most current information before you start any job. Perkins dealers or Perkins distributors have the most current information available.



When replacement parts are required for this product Perkins recommends using Perkins replacement parts.

Failure to heed this warning can lead to premature failures, product damage, personal injury or death.

In the United States, the maintenance, replacement, or repair of the emission control devices and systems may be performed by any repair establishment or individual of the owner's choosing.

Table of Contents

Foreword	4
----------------	---

Safety Section

Safety Messages	6
General Hazard Information.....	17
Burn Prevention.....	20
Fire Prevention and Explosion Prevention.....	22
Crushing Prevention and Cutting Prevention..	24
Mounting and Dismounting	24
High Pressure Fuel Lines	24
Before Starting Engine	27
Engine Starting.....	28
Engine Stopping	28
Electrical System.....	28
Engine Electronics.....	29

Product Information Section

General Information	31
Product Identification Information	51

Operation Section

Lifting and Storage	53
Features and Controls.....	58
Engine Diagnostics	64
Engine Starting.....	65
Engine Operation	69
Cold Weather Operation	71
Engine Stopping	75

Maintenance Section

Refill Capacities.....	76
Maintenance Recommendations	95
Maintenance Interval Schedule.....	98

Warranty Section

Warranty Information.....	147
---------------------------	-----

Reference Information Section

Reference Materials	148
---------------------------	-----

Index Section

Index.....	150
------------	-----

Foreword

California Proposition 65 Warning

Diesel engine exhaust and some of its constituents are known to the State of California to cause cancer, birth defects, and other reproductive harm.



WARNING – This product can expose you to chemicals including ethylene glycol, which is known to the State of California to cause birth defects or other reproductive harm. For more information go to:

www.P65Warnings.ca.gov

Do not ingest this chemical. Wash hands after handling to avoid incidental ingestion.



WARNING – This product can expose you to chemicals including lead and lead compounds, which are known to the State of California to cause cancer, birth defects, or other reproductive harm. For more information go to:

www.P65Warnings.ca.gov

Wash hands after handling components that may contain lead.

Literature Information

This manual contains safety, operation instructions, lubrication, and maintenance information. This manual should be stored in or near the engine area in a literature holder or literature storage area. Read, study, and keep the manual with the literature and engine information.

English is the primary language for all Perkins publications. The English used facilitates translation and consistency.

Some photographs or illustrations in this manual show details or attachments that may be different from your engine. Guards and covers may have been removed for illustrative purposes. Continuing improvement and advancement of product design may have caused changes to your engine which are not included in this manual. Whenever a question arises regarding your engine, or this manual, please consult with your Perkins dealer or your Perkins distributor for the latest available information.

Safety

This safety section lists basic safety precautions. In addition, this section identifies hazardous, warning situations. Read and understand the basic precautions listed in the safety section before operating or performing lubrication, maintenance, and repair on this product.

Operation

Operating techniques outlined in this manual are basic. The operating techniques assist with developing the skills and techniques required to operate the engine more efficiently and economically. Skill and techniques develop as the operator gains knowledge of the engine and the capabilities of the engine.

The operation section is a reference for operators. Photographs and illustrations guide the operator through procedures of inspecting, starting, operating, and stopping the engine. This section also includes a discussion of electronic diagnostic information.

Maintenance

The maintenance section is a guide to engine care. The illustrated, step-by-step instructions are grouped by service hours and/or calendar time maintenance intervals. Items in the maintenance schedule are referenced to detailed instructions that follow.

Recommended service should be performed at the appropriate intervals as indicated in the Maintenance Interval Schedule. The actual operating environment of the engine also governs the Maintenance Interval Schedule. Therefore, under severe, dusty, wet, or freezing cold operating conditions, more frequent lubrication, and maintenance than is specified in the Maintenance Interval Schedule may be necessary.

The maintenance schedule items are organized for a preventive maintenance management program. If the preventive maintenance program is followed, a periodic tune-up is not required. The implementation of a preventive maintenance management program should minimize operating costs through cost avoidances resulting from reductions in unscheduled downtime and failures.

Maintenance Intervals

Perform maintenance on items at multiples of the original requirement. Each level and/or individual items in each level should be shifted ahead or back depending upon your specific maintenance practices, operation, and application. Perkins recommends that the maintenance schedules be reproduced and displayed near the engine as a convenient reminder. Perkins also recommends that a maintenance record be maintained as part of the permanent record of the engine.

Your authorized Perkins dealer or your Perkins distributor can assist you in adjusting your maintenance schedule to meet the needs of your operating environment.

Overhaul

Major engine overhaul details are not covered in the Operation and Maintenance Manual except for the interval and the maintenance items in that interval. Major repairs are best left to trained personnel or an authorized Perkins distributor or dealer. Your Perkins dealer or your Perkins distributor offers various options regarding overhaul programs. If you experience a major engine failure, there are also numerous after failure overhaul options available. Consult with your Perkins dealer or your Perkins distributor for information regarding these options.

Safety Section

i09868653

Safety Messages

There may be several specific warning signs on your engine. The exact location and a description of the warning signs are reviewed in this section. Become familiar with all warning signs.

Ensure that all the warning signs are legible. Clean the warning signs or replace the warning signs if the words cannot be read or if the illustrations are not visible. Use a cloth, water, and soap to clean the warning signs. Do not use solvents, gasoline, or other harsh chemicals. Solvents, gasoline, or harsh chemicals could loosen the adhesive that secures the warning signs. The warning signs that are loosened could drop off the engine.

Replace any warning sign that is damaged or missing. If a warning sign is attached to a part of the engine that is replaced, install a new warning sign on the replacement part. Your Perkins distributor can provide new warning signs.

(1) Universal Warning



Do not operate or work on this equipment unless you have read and understand the instructions and warnings in the Operation and Maintenance Manuals. Failure to follow the instructions or heed the warnings could result in serious injury or death.

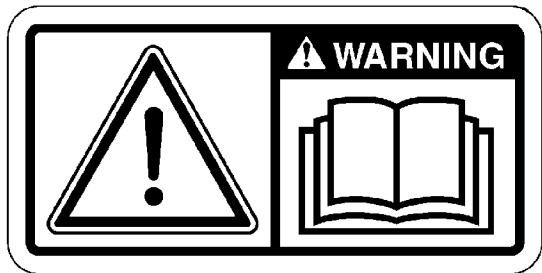

Illustration 1

g01154807

Typical example

The Universal Warning label (1) is on the side of the valve mechanism cover. Refer to illustration 2 .

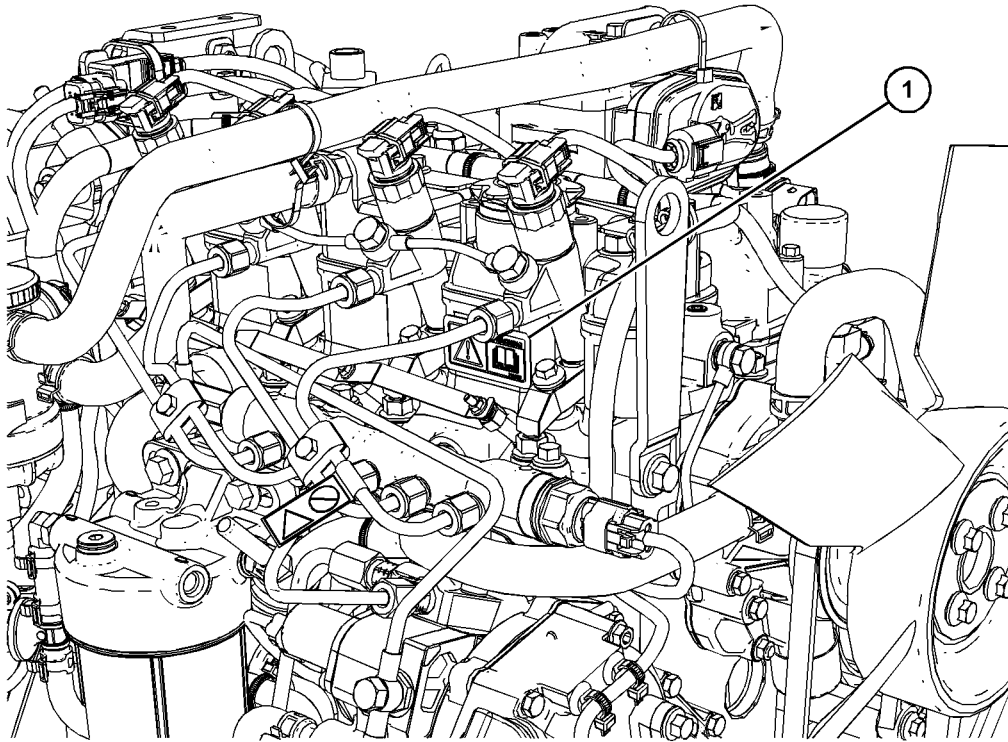

Illustration 2
Typical example

g06310205

(2) Hand (High Pressure)

⚠ WARNING

Contact with high pressure fuel may cause fluid penetration and burn hazards. High pressure fuel spray may cause a fire hazard. Failure to follow these inspection, maintenance and service instructions may cause personal injury or death.



Illustration 3
Typical example

g02382677

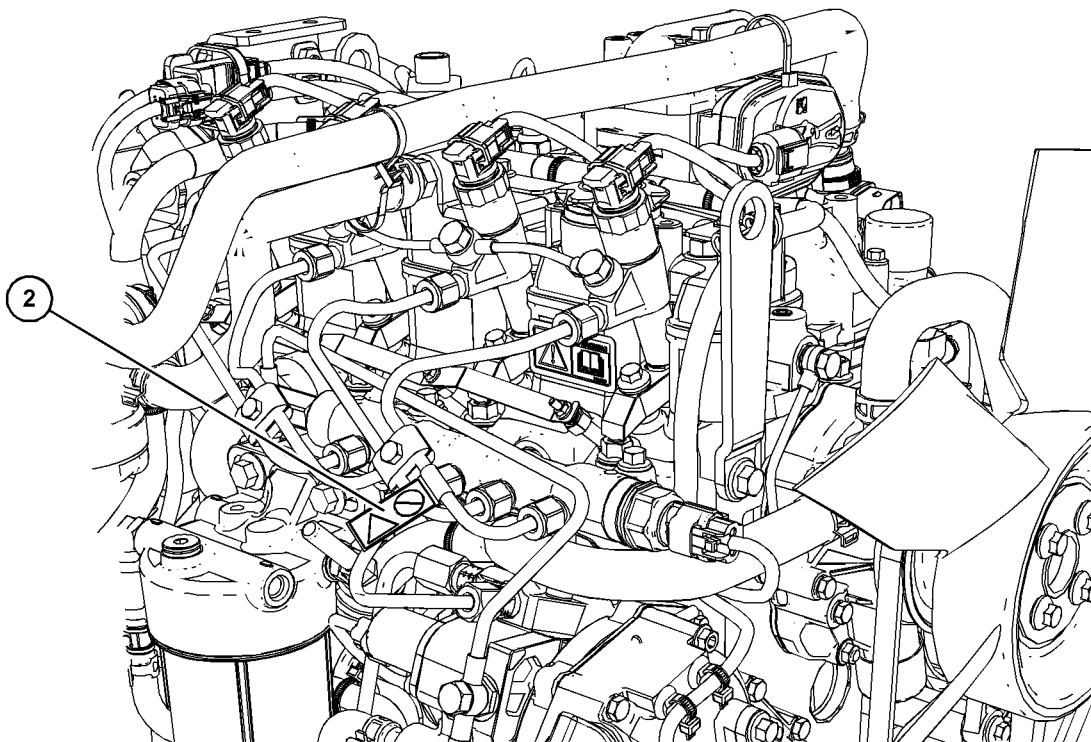

Illustration 4

g06310206

Typical example

The warning label for the Hand (High Pressure) (2) is a wrap around label that is installed on the high-pressure fuel line.

(3) Ether Warning

An ether warning label should be installed on the air cleaner or close to the air cleaner. The location will depend on the application.

WARNING

Do not operate or work on this equipment unless you have read and understand the instructions and warnings in the Operation and Maintenance Manuals. Failure to follow the instructions or heed the warnings could result in serious injury or death.



Illustration 5

g01154809

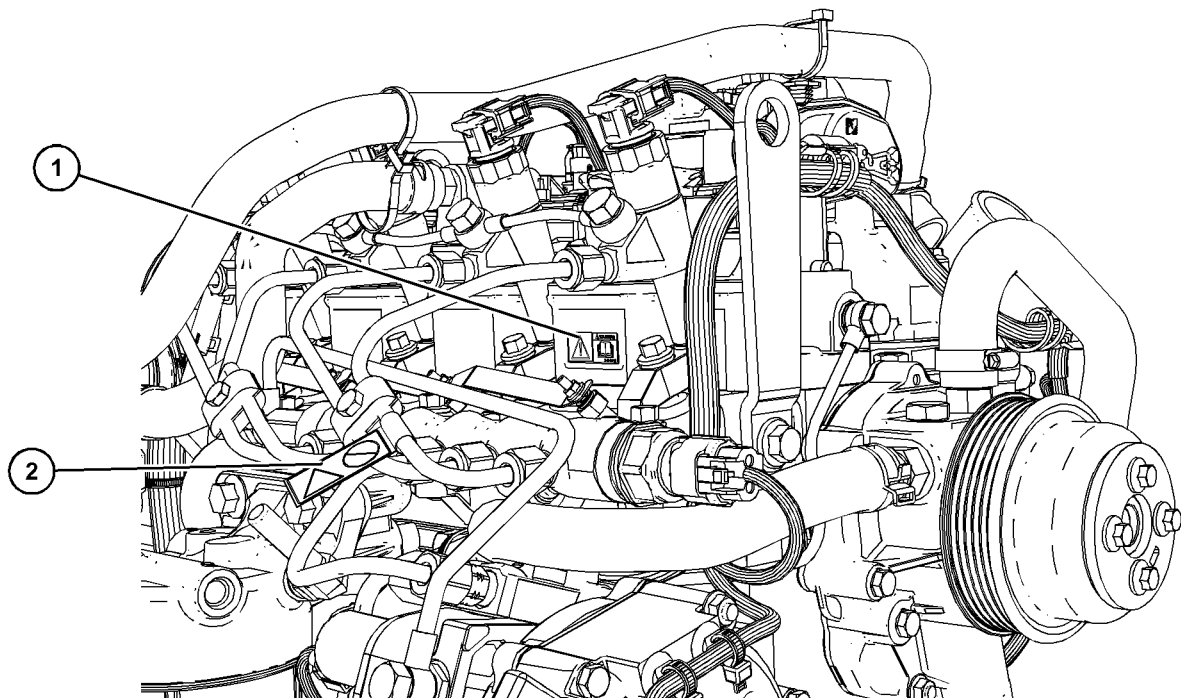

Illustration 6

g06543925

Typical example of an industrial engine fitted with a Balancer

(1) Universal Warning label

(2) Hand (High Pressure) label

Industrial Open Power Unit (IOPU) Engines

4 Cylinder IOPU

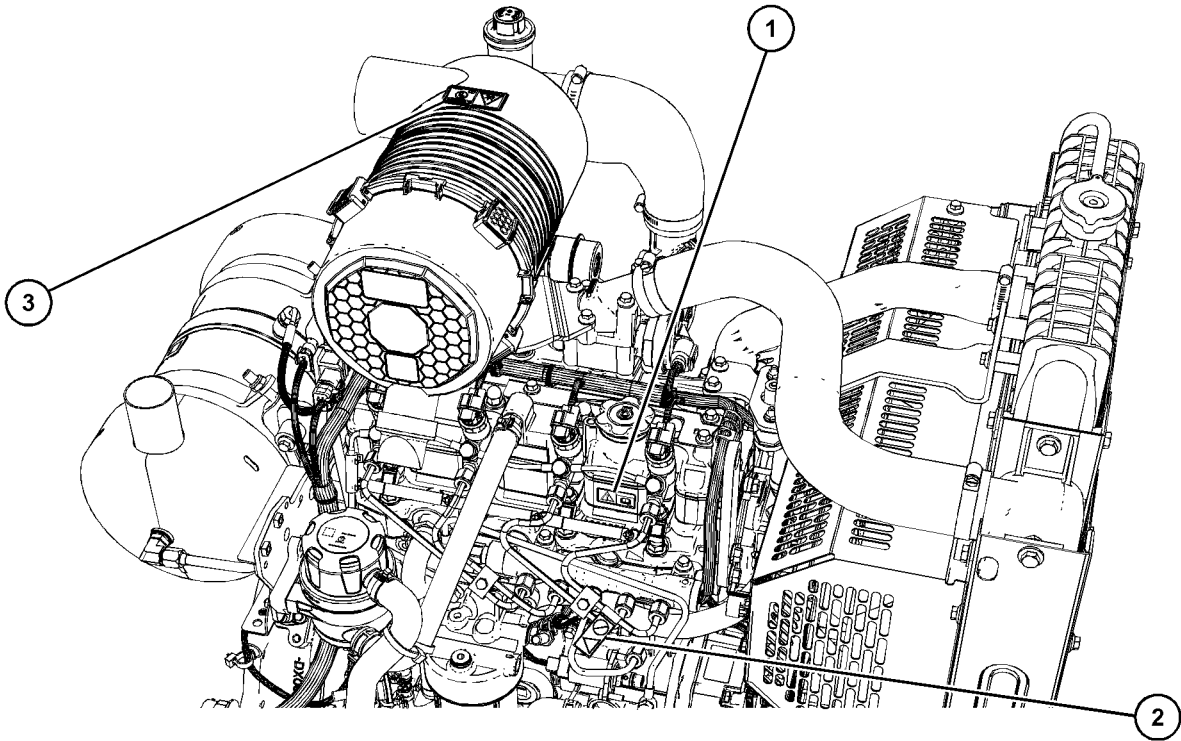

Illustration 7
Typical example

g07520353

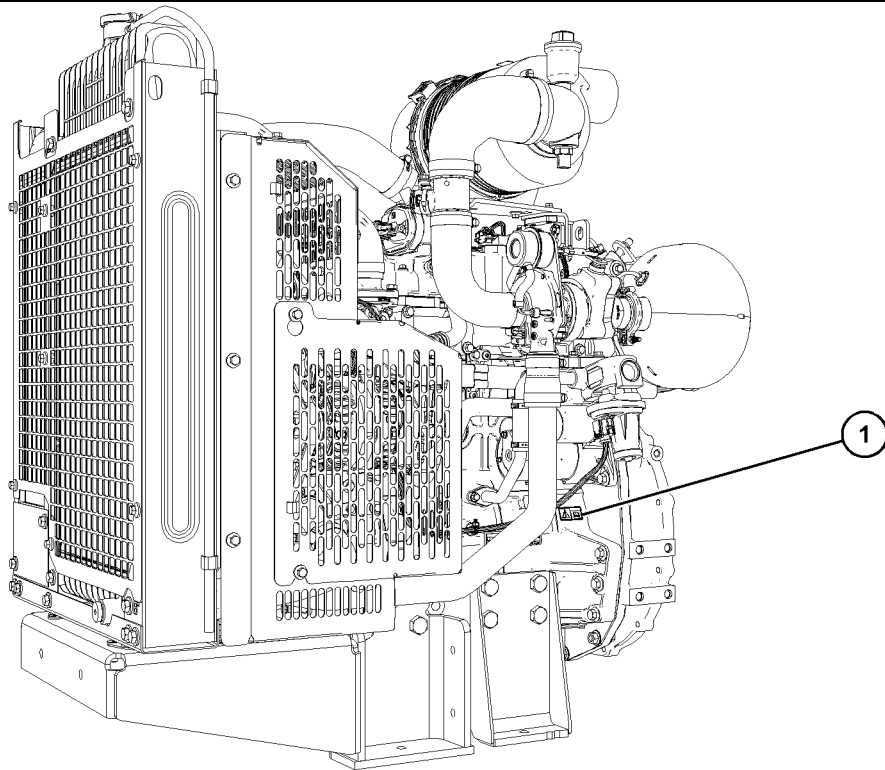

Illustration 8

g07520365

Typical example

(1) Universal Warning



Do not operate or work on this equipment unless you have read and understand the instructions and warnings in the Operation and Maintenance Manuals. Failure to follow the instructions or heed the warnings could result in serious injury or death.

(2) Hand (High Pressure)



Contact with high pressure fuel may cause fluid penetration and burn hazards. High pressure fuel spray may cause a fire hazard. Failure to follow these inspection, maintenance and service instructions may cause personal injury or death.

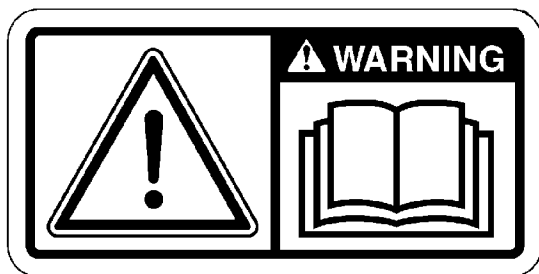

Illustration 9

g01154807

Typical example



Illustration 10

g02382677

Typical example

(3) Ether Warning

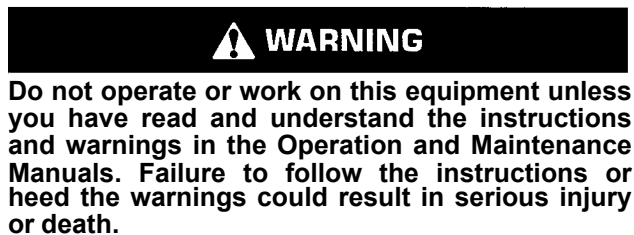

Illustration 11

g01154809

3 Cylinder IOPU

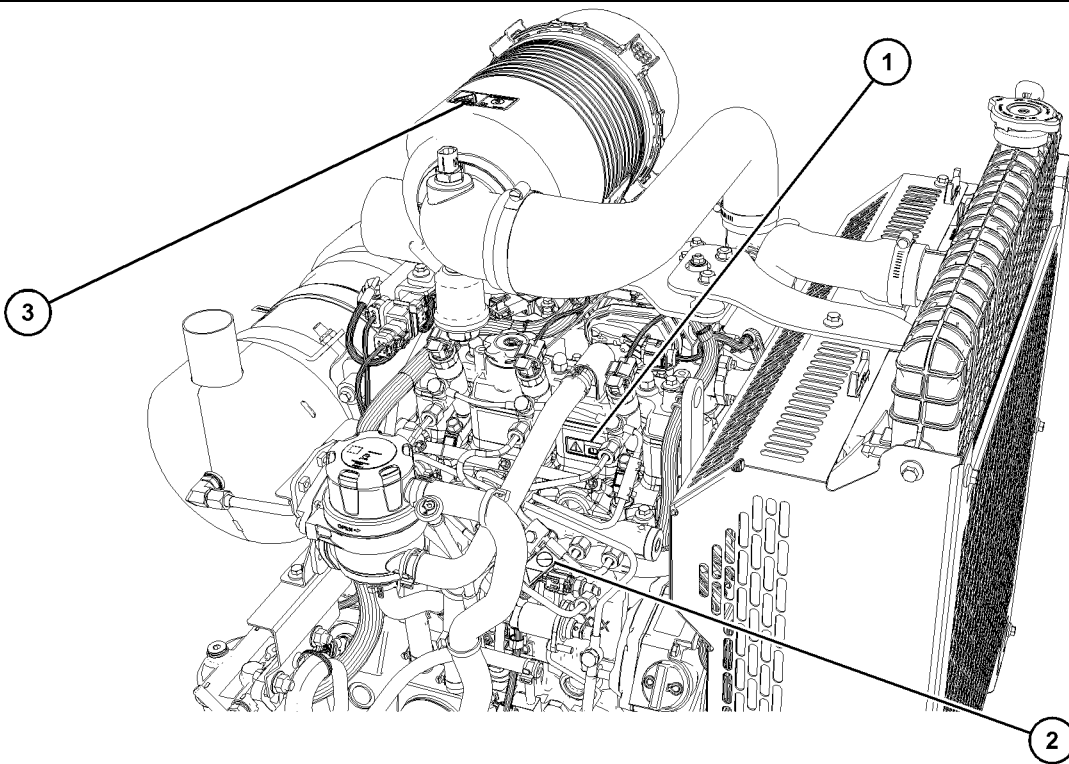

Illustration 12
Typical example

g07520376

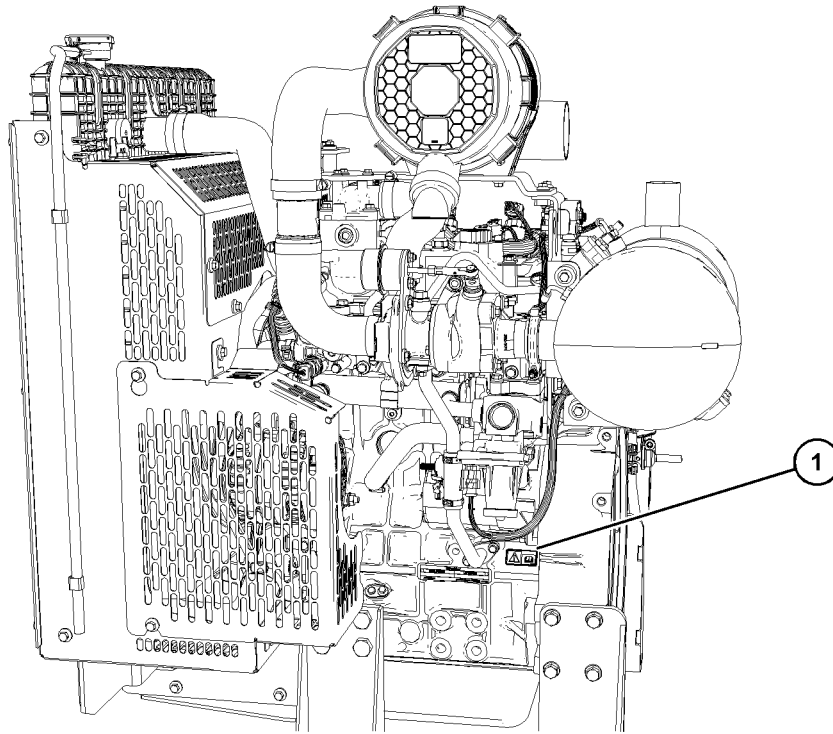

Illustration 13

Typical example

ElectropaK

g07520392

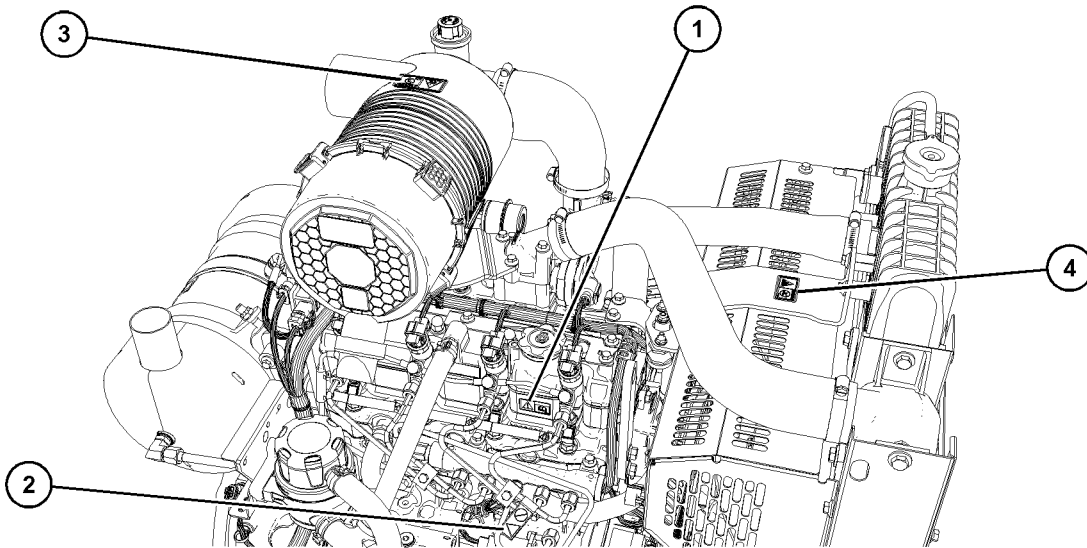

Illustration 14

Typical example

g07625731

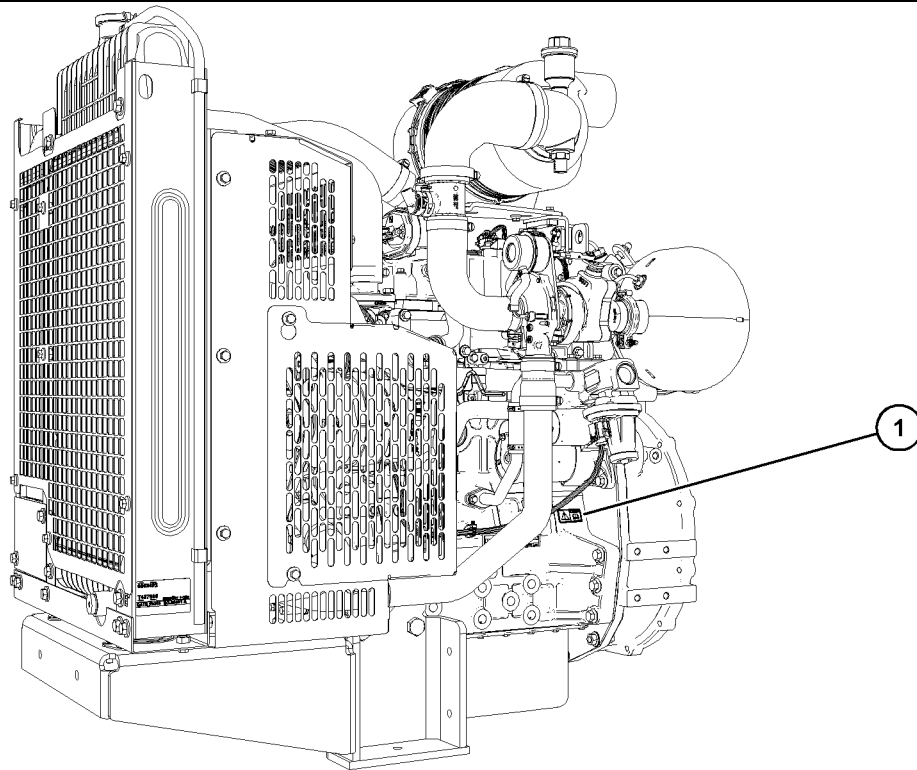

Illustration 15

g07625737

Typical example

1 Universal Warning



Do not operate or work on this equipment unless you have read and understand the instructions and warnings in the Operation and Maintenance Manuals. Failure to follow the instructions or heed the warnings could result in serious injury or death.

2 Hand (High Pressure)



Contact with high pressure fuel may cause fluid penetration and burn hazards. High pressure fuel spray may cause a fire hazard. Failure to follow these inspection, maintenance and service instructions may cause personal injury or death.

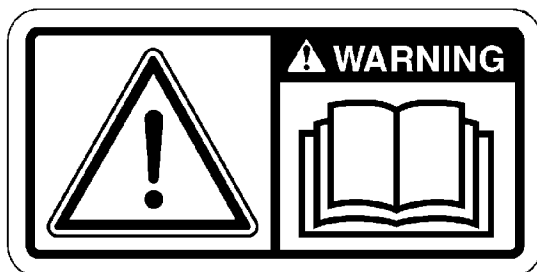

Illustration 16

g01154807

Typical example



Illustration 17

g02382677

Typical example

3 Ether Warning

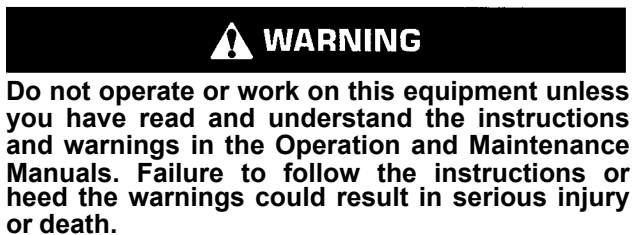

Illustration 18

g01154809

4 Hot Fluid Under Pressure

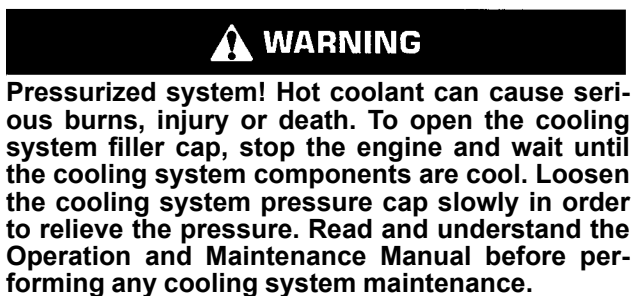



Illustration 19

g01371640

The hot fluids under pressure label(4) is installed on the upper radiator support bracket.

i08314780

General Hazard Information

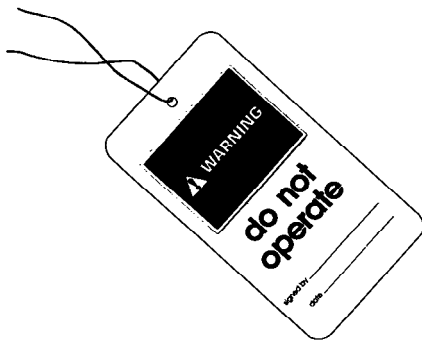

Illustration 20

g00104545

Attach a “Do Not Operate” warning tag or a similar warning tag to the start switch or to the controls before the engine is serviced or before the engine is repaired. Attach the warning tags to the engine and to each operator control station. When appropriate, disconnect the starting controls.

Do not allow unauthorized personnel on the engine, or around the engine when the engine is being serviced.

- Tampering with the engine installation or tampering with the OEM supplied wiring can be dangerous. Personal injury, death and/or engine damage could result.
- Vent the engine exhaust to the outside when the engine is operated in an enclosed area.

- If the engine is not running, do not release the secondary brake or the parking brake systems unless the vehicle is blocked or unless the vehicle is restrained.

Unless other instructions are provided, perform the maintenance under the following conditions:

- The key switch is in the OFF position.
- The engine is stopped. Ensure that the engine cannot be started.
- The protective locks or the controls are in the applied position.
- Engage the secondary brakes or parking brakes.
- Block the vehicle or restrain the vehicle before maintenance or repairs are performed.
- After the ECM has powered down, disconnect the batteries when maintenance is performed or when the electrical system is serviced. Disconnect the battery ground leads. Use electrical insulating tape on the leads to help prevent sparks.
- If equipped, disconnect the connectors for the unit injectors that are located on the valve cover base. This action will help prevent personal injury from the high voltage to the unit injectors. Do not come in contact with the unit injector terminals while the engine is operating.
- Do not attempt any repairs or any adjustments to the engine while the engine is operating.
- Do not attempt any repairs that are not understood. Use the proper tools. Replace any equipment that is damaged or repair the equipment.
- For initial start-up of a new engine or for starting an engine that has been serviced, make provisions to stop the engine if an overspeed occurs. The stopping of the engine may be accomplished by shutting off the fuel supply and/or the air supply to the engine. Ensure that only the fuel supply line is shut off. Ensure that the fuel return line is open.
- Start the engine from the operators station (cab). Never short across the starting motor terminals or the batteries. This action could bypass the engine neutral start system and/or the electrical system could be damaged.

Engine exhaust contains products of combustion which may be harmful to your health. Always start the engine and operate the engine in a well ventilated area. If the engine is in an enclosed area, vent the engine exhaust to the outside.

Safety Section
General Hazard Information

To help prevent spraying or splashing of pressurized fluids, hold a rag over the part that is being removed.

Remove the following parts with caution.

- Filler caps
- Grease fittings
- Pressure taps
- Breathers
- Drain plugs

Use caution when cover plates are removed. Gradually loosen, but do not remove the last two bolts or nuts that are located at opposite ends of the cover plate or the device. Before removing the last two bolts or nuts, pry the cover loose to relieve any spring pressure or other pressure.

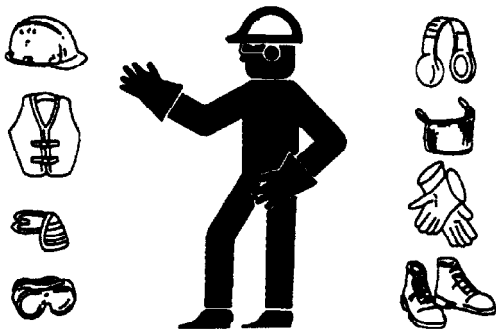

Illustration 21

g00702020

- Do not stand on the engine.
- Wear a hard hat, protective glasses, and other protective equipment, as required.
- Perkins recommends that you do not stand next to an exposed running engine unless it is necessary when carrying out daily checks or maintenance procedures. The appropriate Personal Protective Equipment (PPE) must be worn when standing next to an exposed running engine.
- Do not wear loose clothing or jewelry that can snag on controls or on other parts of the engine.
- Ensure that all protective guards and all covers are secured in place on the engine.
- Never put maintenance fluids into glass containers. Glass containers can break.
- Use all cleaning solutions with care.
- Report all necessary repairs.

Pressurized Air and Water

Pressurized air and/or water can cause debris and/or hot water to be blown out. This action could result in personal injury.

When pressurized air and/or pressurized water is used for cleaning, wear protective clothing, protective shoes, and eye protection. Eye protection includes goggles or a protective face shield.

The maximum air pressure for cleaning purposes must be below 205 kPa (30 psi). The maximum water pressure for cleaning purposes must be below 275 kPa (40 psi).

Fluid Penetration

Pressure can be trapped in the hydraulic circuit long after the engine has been stopped. The pressure can cause hydraulic fluid or items such as pipe plugs to escape rapidly if the pressure is not relieved correctly.

Do not remove any hydraulic components or parts until pressure has been relieved or personal injury may occur. Do not disassemble any hydraulic components or parts until pressure has been relieved or personal injury may occur. Refer to the OEM information for any procedures that are required to relieve the hydraulic pressure.

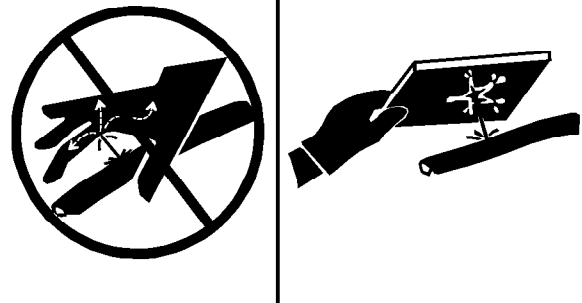

Illustration 22

g00687600

Always use a board or cardboard when you check for a leak. Leaking fluid that is under pressure can penetrate body tissue. Fluid penetration can cause serious injury and possible death. A pin hole leak can cause severe injury. If fluid is injected into your skin, you must get treatment immediately. Seek treatment from a doctor that is familiar with this type of injury.

Containing Fluid Spillage

Care must be taken to ensure that fluids are contained during performance of inspection, maintenance, testing, adjusting, and repair of the product. Be prepared to collect the fluid with suitable containers before opening any compartment or disassembling any component containing fluids.

Dispose of all fluids according to local regulations and mandates.

Static Electricity Hazard when Fueling with Ultra-low Sulfur Diesel Fuel

The removal of sulfur and other compounds in ultra-low sulfur diesel fuel (ULSD fuel) decreases the conductivity of ULSD and increases the ability of ULSD to store static charge. Refineries may have treated the fuel with a static dissipating additive. Many factors can reduce the effectiveness of the additive over time. Static charges can build up in ULSD fuel while the fuel is flowing through fuel delivery systems. Static electricity discharge when combustible vapors are present could result in a fire or explosion. Ensure that the entire system used to refuel your machine (fuel supply tank, transfer pump, transfer hose, nozzle, and others) is properly grounded and bonded.

WARNING

Avoid static electricity risk when fueling. Ultra-low sulfur diesel fuel (ULSD fuel) poses a greater static ignition hazard than earlier diesel formulations with a higher sulfur contents. Avoid death or serious injury from fire or explosion. Consult with your fuel or fuel system supplier to ensure the delivery system is in compliance with fueling standards for proper grounding and bonding practices.

Inhalation

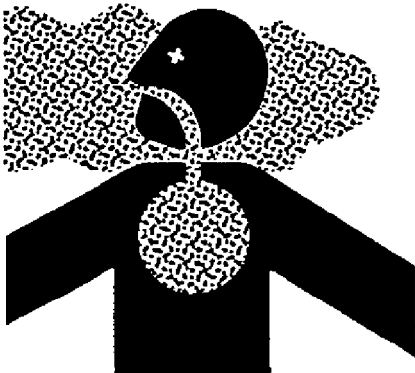

Illustration 23

g00702022

Exhaust

Use caution. Exhaust fumes can be hazardous to health. If you operate the equipment in an enclosed area, adequate ventilation is necessary.

Hexavalent Chromium

Perkins equipment and replacement parts comply with applicable regulations and requirements where originally sold. Perkins recommends the use of only genuine Perkins replacement parts.

Hexavalent chromium has occasionally been detected on exhaust and heat shield systems on Perkins engines. Although laboratory testing is the only accurate way to know if hexavalent chromium is, in fact, present, the presence of a yellow deposit in areas of high heat (for example, exhaust system components or exhaust insulation) may be an indication of the presence of hexavalent chromium.

Use caution if you suspect the presence of hexavalent chromium. Avoid skin contact when handling items that you suspect may contain hexavalent chromium, and avoid inhalation of any dust in the suspect area. Inhalation of, or skin contact with, hexavalent chromium dust may be hazardous to your health.

If such yellow deposits are found on the engine, engine component parts, or associated equipment or packages, Perkins recommends following local health and safety regulations and guidelines, utilizing good hygiene, and adhering to safe work practices when handling the equipment or parts. Perkins also recommends the following:

- Wear appropriate Personal Protective Equipment (PPE)
- Wash your hands and face with soap and water prior to eating, drinking, or smoking, and also during rest room breaks, to prevent ingestion of any yellow powder
- Never use compressed air for cleaning areas suspected of containing hexavalent chromium
- Avoid brushing, grinding, or cutting materials suspected of containing hexavalent chromium
- Obey environmental regulations for the disposal of all materials that may contain or have come into contact with hexavalent chromium
- Stay away from areas that might have hexavalent chromium particles in the air.

Asbestos Information

Perkins equipment and replacement parts that are shipped from Perkins engine company limited are asbestos free. Perkins recommends the use of only genuine Perkins replacement parts. Use the following guidelines when you handle any replacement parts that contain asbestos or when you handle asbestos debris.

Use caution. Avoid inhaling dust that might be generated when you handle components that contain asbestos fibers. Inhaling this dust can be hazardous to your health. The components that may contain asbestos fibers are brake pads, brake bands, lining material, clutch plates, and some gaskets. The asbestos that is used in these components is usually bound in a resin or sealed in some way. Normal handling is not hazardous unless airborne dust that contains asbestos is generated.

If dust that may contain asbestos is present, there are several guidelines that should be followed:

- Never use compressed air for cleaning.
- Avoid brushing materials that contain asbestos.
- Avoid grinding materials that contain asbestos.
- Use a wet method to clean up asbestos materials.
- A vacuum cleaner that is equipped with a high efficiency particulate air filter (HEPA) can also be used.
- Use exhaust ventilation on permanent machining jobs.
- Wear an approved respirator if there is no other way to control the dust.
- Comply with applicable rules and regulations for the work place. In the United States, use Occupational Safety and Health Administration (OSHA) requirements. These OSHA requirements can be found in "29 CFR 1910.1001".
- Obey environmental regulations for the disposal of asbestos.

- Stay away from areas that might have asbestos particles in the air.

Dispose of Waste Properly

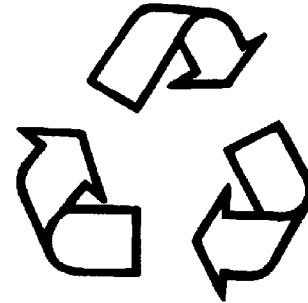

Illustration 24

g00706404

Improperly disposing of waste can threaten the environment. Potentially harmful fluids should be disposed of according to local regulations.

Always use leakproof containers when you drain fluids. Do not pour waste onto the ground, down a drain, or into any source of water.

i07397452

Burn Prevention

Do not touch any part of an operating engine system. The engine, the exhaust, and the engine aftertreatment system can reach temperatures as high as 650° C (1202° F) under normal operating conditions.

Allow the engine system to cool before any maintenance is performed. Relieve all pressure in the air system, hydraulic system, lubrication system, fuel system, and the cooling system before the related items are disconnected.

WARNING

Contact with high pressure fuel may cause fluid penetration and burn hazards. High pressure fuel spray may cause a fire hazard. Failure to follow these inspection, maintenance and service instructions may cause personal injury or death.

After the engine has stopped, wait for 10 minutes to allow the fuel pressure to be purged from the high-pressure fuel lines before any service or repair is performed on the engine fuel lines. The 10 minute wait will also allow static charge to dissipate from the low-pressure fuel system.

Allow the pressure to be purged in the air system, in the hydraulic system, in the lubrication system, or in the cooling system before any lines, fittings, or related items are disconnected.

Induction System

WARNING

Sulfuric Acid Burn Hazard may cause serious personal injury or death.

The exhaust gas cooler may contain a small amount of sulfuric acid. The use of fuel with sulfur levels greater than 15 ppm may increase the amount of sulfuric acid formed. The sulfuric acid may spill from the cooler during service of the engine. The sulfuric acid will burn the eyes, skin and clothing on contact. Always wear the appropriate personal protective equipment (PPE) that is noted on a material safety data sheet (MSDS) for sulfuric acid. Always follow the directions for first aid that are noted on a material safety data sheet (MSDS) for sulfuric acid.

Coolant

When the engine is at operating temperature, the engine coolant is hot. The coolant is also under pressure. The radiator and all lines to the heaters, aftertreatment system or to the engine contain hot coolant.

Any contact with hot coolant or with steam can cause severe burns. Allow cooling system components to cool before the cooling system is drained.

Check that the coolant level after the engine has stopped and the engine has been allowed to cool.

Ensure that the filler cap is cool before removing the filler cap. The filler cap must be cool enough to touch with a bare hand. Remove the filler cap slowly to relieve pressure.

Cooling system conditioner contains alkali. Alkali can cause personal injury. Do not allow alkali to contact the skin, the eyes, or the mouth.

Oils

Skin may be irritated following repeated or prolonged exposure to mineral and synthetic base oils. Refer to your suppliers Material Safety Data Sheets for detailed information. Hot oil and lubricating components can cause personal injury. Do not allow hot oil to contact the skin. Appropriate personal protective equipment should be used.

Diesel Fuel

Diesel engines have high-pressure fuel systems and the fuel can reach temperatures of over 100° C (212° F). Ensure that the fuel has cooled before any service or repairs are performed.

Diesel may be irritating to the eyes, respiratory system, and skin. Prolonged exposure to diesel may cause various skin conditions. Appropriate personal protective equipment should be used. Refer to supplier Material safety Data sheets for detailed information.

Batteries

Electrolyte is an acid. Electrolyte can cause personal injury. Do not allow electrolyte to contact the skin or the eyes. Always wear protective glasses for servicing batteries. Wash hands after touching the batteries and connectors. Use of gloves is recommended.

Engine and Aftertreatment System

Do not touch any part of an operating engine or engine aftertreatment system. Allow the engine or the engine aftertreatment system to cool before any maintenance is performed on the engine or the engine aftertreatment system. Relieve all pressure in the appropriate system before any lines, fittings, or related items are disconnected.

i07905919

Fire Prevention and Explosion Prevention



Illustration 25

g00704000

All fuels, most lubricants, and some coolant mixtures are flammable.

Flammable fluids that are leaking or spilled onto hot surfaces or onto electrical components can cause a fire. Fire may cause personal injury and property damage.

After the emergency stop button is operated, ensure that you allow 15 minutes, before the engine covers are removed.

Determine whether the engine will be operated in an environment that allows combustible gases to be drawn into the air inlet system. These gases could cause the engine to overspeed. Personal injury, property damage, or engine damage could result.

If the application involves the presence of combustible gases, consult your Perkins dealer and/or your Perkins distributor for additional information about suitable protection devices.

Remove all flammable combustible materials or conductive materials such as fuel, oil, and debris from the engine. Do not allow any flammable combustible materials or conductive materials to accumulate on the engine.

Store fuels and lubricants in correctly marked containers away from unauthorized persons. Store oily rags and any flammable materials in protective containers. Do not smoke in areas that are used for storing flammable materials.

Do not expose the engine to any flame.

Exhaust shields (if equipped) protect hot exhaust components from oil or fuel spray if there was a line, a tube, or a seal failure. Exhaust shields must be installed correctly.

Do not weld on lines or tanks that contain flammable fluids. Do not flame cut lines or tanks that contain flammable fluid. Clean any such lines or tanks thoroughly with a nonflammable solvent prior to welding or flame cutting.

Wiring must be kept in good condition. Ensure that all electrical wires are correctly installed and securely attached. Check all electrical wires daily. Repair any wires that are loose or frayed before you operate the engine. Clean all electrical connections and tighten all electrical connections.

Eliminate all wiring that is unattached or unnecessary. Do not use any wires or cables that are smaller than the recommended gauge. Do not bypass any fuses and/or circuit breakers.

Arcing or sparking could cause a fire. Secure connections, recommended wiring, and correctly maintained battery cables will help to prevent arcing or sparking.

WARNING

Contact with high pressure fuel may cause fluid penetration and burn hazards. High pressure fuel spray may cause a fire hazard. Failure to follow these inspection, maintenance and service instructions may cause personal injury or death.

After the engine has stopped, you must wait for 10 minutes to allow the fuel pressure to be purged from the high-pressure fuel lines before any service or repair is performed on the engine fuel lines. The 10 minute wait will also allow static charge to dissipate from the low-pressure fuel system.

Ensure that the engine is stopped. Inspect all lines and hoses for wear or for deterioration. Ensure that the hoses are correctly routed. The lines and hoses must have adequate support and secure clamps. If any fuel lines or fuel hoses become kinked, the fuel line or fuel hose must be replaced. Refer to the Disassembly and Assembly manual for more information.

Oil filters and fuel filters must be correctly installed. The filter housings must be tightened to the correct torque. Refer to the Disassembly and Assembly manual for more information.



Illustration 26

g00704059

Use caution when you are refueling an engine. Do not smoke while you are refueling an engine. Do not refuel an engine near open flames or sparks. Always stop the engine before refueling.

Avoid static electricity risk when fueling. Ultra-low Sulfur Diesel fuel (ULSD fuel) poses a greater static ignition hazard than earlier diesel formulations with a higher sulfur content. Avoid death or serious injury from fire or explosion. Consult your fuel or fuel system supplier to ensure that the delivery system is in compliance with fueling standards for proper grounding and bonding practices.

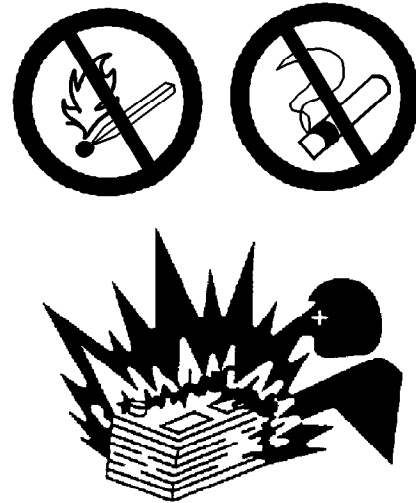

Illustration 27

g00704135

Gases from a battery can explode. Keep any open flames or sparks away from the top of a battery. Do not smoke in battery charging areas.

Never check the battery charge by placing a metal object across the terminal posts. Use a voltmeter or a hydrometer.

Incorrect jumper cable connections can cause an explosion that can result in injury. Refer to the Operation Section of this manual for specific instructions.

Do not charge a frozen battery. A frozen battery may cause an explosion.

The batteries must be kept clean. The covers (if equipped) must be kept on the cells. Use the recommended cables, connections, and battery box covers when the engine is operated.

Fire Extinguisher

Make sure that a fire extinguisher is available. Be familiar with the operation of the fire extinguisher. Inspect the fire extinguisher and service the fire extinguisher regularly. Obey the recommendations on the instruction plate.

Ether

**WARNING**

Do not use aerosol types of starting aids such as ether. Such use could result in an explosion and personal injury.

Ether is flammable and poisonous.

i05768982

Lines, Tubes, and Hoses

Do not bend high-pressure lines. Do not strike high-pressure lines. Do not install any lines that are damaged.

Leaks can cause fires. Consult your Perkins dealer or your Perkins distributor for replacement parts.

Replace the parts if any of the following conditions are present:

- High-pressure fuel line or lines are removed.
- End fittings are damaged or leaking.
- Outer coverings are chafed or cut.
- Wires are exposed.
- Outer coverings are ballooning.
- Flexible parts of the hoses are kinked.
- Outer covers have embedded armor.
- End fittings are displaced.

Make sure that all clamps, guards, and heat shields are installed correctly. During engine operation, correct installation will help to prevent vibration, rubbing against other parts, and excessive heat.

i02143194

Crushing Prevention and Cutting Prevention

Support the component correctly when work beneath the component is performed.

Unless other maintenance instructions are provided, never attempt adjustments while the engine is running.

Stay clear of all rotating parts and of all moving parts. Leave the guards in place until maintenance is performed. After the maintenance is performed, reinstall the guards.

Keep objects away from moving fan blades. The fan blades will throw objects or cut objects.

When objects are struck, wear protective glasses in order to avoid injury to the eyes.

Chips or other debris may fly off objects when objects are struck. Before objects are struck, ensure that no one will be injured by flying debris.

Mounting and Dismounting

Do not climb on the engine or the engine aftertreatment system. The engine and aftertreatment system have not been designed with mounting or dismounting locations.

Refer to the OEM for the location of foot and hand holds for your specific application.

i06662133

High Pressure Fuel Lines

WARNING

Contact with high pressure fuel may cause fluid penetration and burn hazards. High pressure fuel spray may cause a fire hazard. Failure to follow these inspection, maintenance and service instructions may cause personal injury or death.

The high-pressure fuel lines are the fuel lines that are between the high-pressure fuel pump and the high-pressure fuel manifold and the fuel lines that are between the fuel manifold and cylinder head. These fuel lines are different from fuel lines on other fuel systems.

The different is because of the following items:

- The high-pressure fuel lines are constantly charged with high pressure.
- The internal pressures of the high-pressure fuel lines are higher than other types of fuel system.
- The high-pressure fuel lines are formed to shape and then strengthened by a special process.

Do not step on the high-pressure fuel lines. Do not deflect the high-pressure fuel lines. Do not bend or strike the high-pressure fuel lines. Deformation or damage of the high-pressure fuel lines may cause a point of weakness and potential failure.

Do not check the high-pressure fuel lines with the engine or the starting motor in operation. After the engine has stopped, you must wait for 10 minutes to allow the fuel pressure to be purged from the high-pressure fuel lines before any service or repair is performed on the engine fuel lines. The 10 minute wait will also allow static charge to dissipate from the low-pressure fuel system.

Do not loosen the high-pressure fuel lines to remove air from the fuel system. This procedure is not required.

Visually inspect the high-pressure fuel lines before the engine is started. This inspection should be each day.

If you inspect the engine in operation, always use the proper inspection procedure to avoid a fluid penetration hazard. Refer to Operation and Maintenance Manual, "General hazard Information".

- Inspect the high-pressure fuel lines for damage, deformation, a nick, a cut, a crease, or a dent.
- Do not operate the engine with a fuel leak. If there is a leak, do not tighten the connection to stop the leak. The connection must only be tightened to the recommended torque. Refer to Disassembly and Assembly, "Fuel injection lines - Remove and Fuel injection lines - Install".
- If the high-pressure fuel lines are torqued correctly and the high-pressure fuel lines are leaking, the high-pressure fuel lines must be replaced.
- Ensure that all clips on the high-pressure fuel lines are in place. Do not operate the engine with clips that are damaged, missing, or loose.
- Do not attach any other item to the high-pressure fuel lines.
- Loosened high-pressure fuel lines must be replaced. Also removed high-pressure fuel lines must be replaced. Refer to Disassembly and assembly manual, "Fuel Injection Lines - Install".

Four Cylinder engine

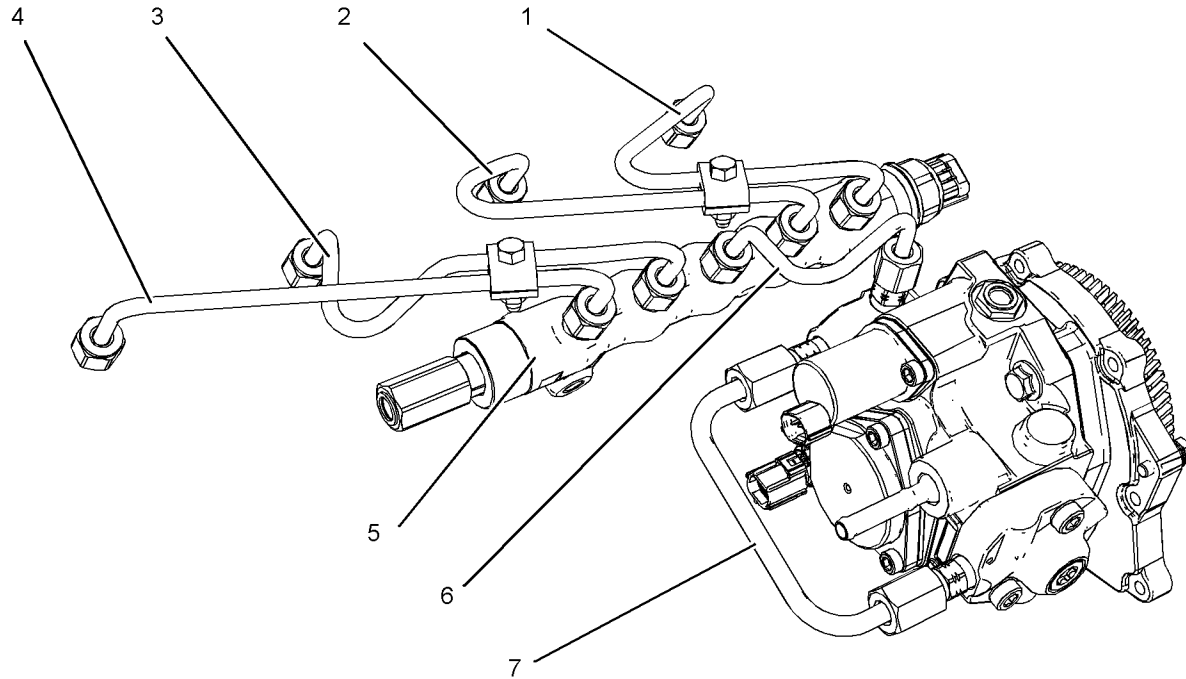

Illustration 28

g03886691

(1) High-pressure line
(2) High-pressure line
(3) High-pressure line

(4) High-pressure line
(5) High-pressure fuel manifold (rail)
(6) High-pressure line

(7) Fuel transfer line that is high pressure

Three Cylinder Engine

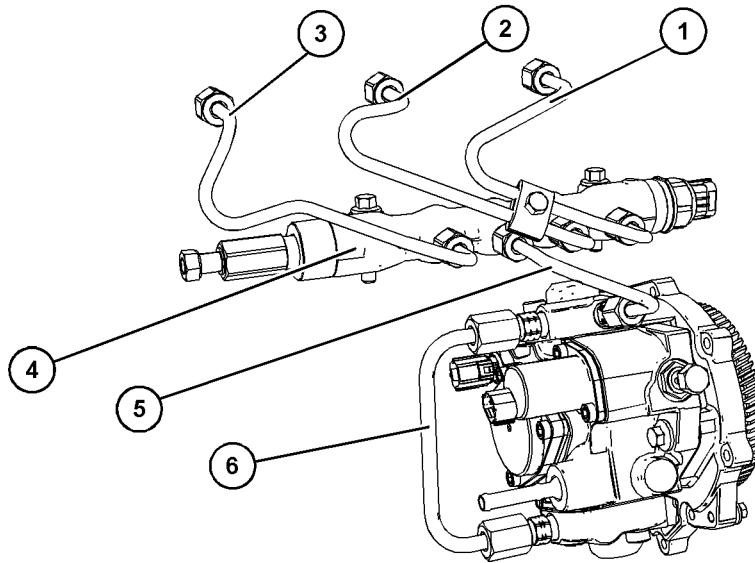

Illustration 29

g06064715

Typical example

(1) High-pressure line
(2) High-pressure line

(3) High-pressure line
(4) High-pressure fuel manifold

(5) High-pressure line
(6) Fuel transfer line that is high pressure

i08614835

Before Starting Engine

NOTICE

For initial start-up of a new or rebuilt engine, and for start-up of an engine that has been serviced, make provision to shut the engine off should an overspeed occur. This may be accomplished by shutting off the air and/or fuel supply to the engine.

WARNING

Engine exhaust contains products of combustion which may be harmful to your health. Always start and operate the engine in a well ventilated area and, if in an enclosed area, vent the exhaust to the outside.

Inspect the engine for potential hazards.

Do not start the engine if there is a "DO NOT OPERATE" warning tag or similar warning tag attached to the start switch. Do not move any of the controls if there is a "DO NOT OPERATE" warning tag or similar warning tag attached to the controls.

Before starting the engine, ensure that no one is on, underneath, or close to the engine. Ensure that the area is free of personnel.

If equipped, ensure that the lighting system for the engine is suitable for the conditions. Ensure that all lights work properly, if equipped.

All protective guards and all protective covers must be installed if the engine must be started to perform service procedures. To help prevent an accident that is caused by parts in rotation, work around the parts carefully.

Do not bypass the automatic shutoff circuits. Do not disable the automatic shutoff circuits. The circuits are provided to help prevent personal injury. The circuits are also provided to help prevent engine damage.

See the Service Manual for repairs and for adjustments.

i07905943

i02234873

Engine Starting

WARNING

Do not use aerosol types of starting aids such as ether. Such use could result in an explosion and personal injury.

If a warning tag is attached to the engine start switch, or to the controls DO NOT start the engine or move the controls. Consult with the person that attached the warning tag before the engine is started.

All protective guards and all protective covers must be installed if the engine must be started to perform service procedures. To help prevent an accident that is caused by parts in rotation, work around the parts carefully.

Start the engine from the operator's compartment or from the engine start switch.

Always start the engine according to the procedure described in the Operation and Maintenance Manual, "Engine Starting" topic in the Operation Section. Knowing the correct procedure will help to prevent major damage to the engine components. Knowing the procedure will also help to prevent personal injury.

To ensure that the jacket water heater (if equipped) and/or the lube oil heater (if equipped) is working correctly, check the water temperature gauge. Also, check the oil temperature gauge during the heater operation.

Engine exhaust contains products of combustion which can be harmful to health. Always start the engine and operate the engine in a well ventilated area. If the engine is started in an enclosed area, vent the engine exhaust to the outside.

Note: The engine is equipped with a device for cold starting. If the engine will be operated in very cold conditions, an extra cold starting aid may be required. Normally, the engine will be equipped with the correct type of starting aid for the region of operation.

These engines are equipped with a glow plug starting aid in each cylinder which heats the intake air to improve starting.

Engine Stopping

Stop the engine according to the procedure in the Operation and Maintenance Manual, "Engine Stopping (Operation Section)" in order to avoid overheating of the engine and accelerated wear of the engine components.

Use the Emergency Stop Button (if equipped) ONLY in an emergency situation. Do not use the Emergency Stop Button for normal engine stopping. After an emergency stop, DO NOT start the engine until the problem that caused the emergency stop has been corrected.

Stop the engine if an overspeed condition occurs during the initial start-up of a new engine or an engine that has been overhauled.

To stop an electronically controlled engine, cut the power to the engine and/or shutting off the air supply to the engine.

i07398900

Electrical System

Never disconnect any charging unit circuit or battery circuit cable from the battery when the charging unit is operating. A spark can cause the combustible gases that are produced by some batteries to ignite.

To help prevent sparks from igniting combustible gases that are produced by some batteries, the negative "-" cable should be connected last from the external power source to the primary position for grounding.

Check the electrical wires daily for wires that are loose or frayed. Tighten all loose electrical connections before the engine is started. Repair all frayed electrical wires before the engine is started. See the Operation and Maintenance Manual for specific starting instructions.

Grounding Practices

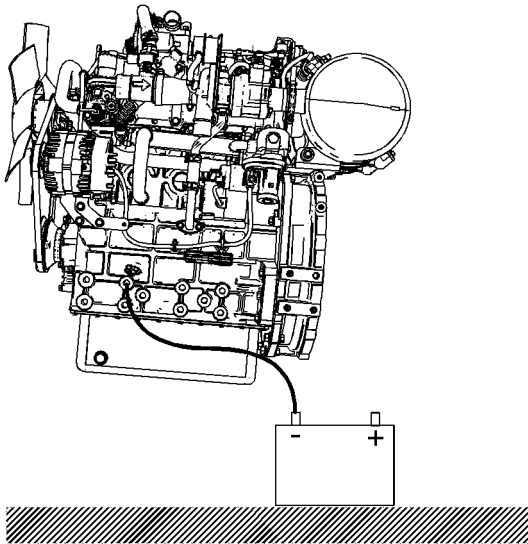

Illustration 30

g06310210

Typical example
Ground to battery

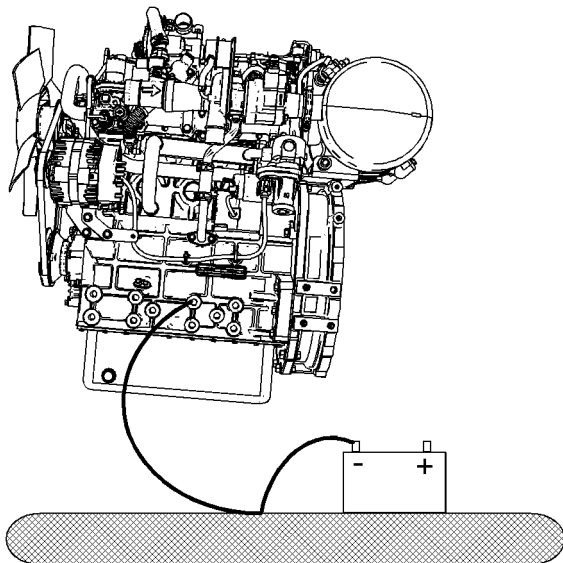

Illustration 31

g06310211

Typical example
Alternate ground to battery

Correct grounding for the engine electrical system is necessary for optimum engine performance and reliability. Incorrect grounding will result in uncontrolled electrical circuit paths and in unreliable electrical circuit paths.

Uncontrolled electrical circuit paths can result in damage to the crankshaft bearing journal surfaces and to aluminum components.

Engines that are installed without engine-to-frame ground straps can be damaged by electrical discharge.

To ensure that the engine and the engine electrical systems function correctly, an engine-to-frame ground strap with a direct path to the battery must be used. This path may be provided by way of a direct engine ground to the frame.

The connections for the grounds should be tight and free of corrosion. The engine alternator must be grounded to the negative “-” battery terminal with a wire that is adequate to handle the full charging current of the alternator.

The power supply connections and the ground connections for the engine electronics should always be from the isolator to the battery.

i07397449

Engine Electronics

⚠ WARNING

Tampering with the electronic system installation or the OEM wiring installation can be dangerous and could result in personal injury or death and/or engine damage.

⚠ WARNING

Electrical Shock Hazard. The electronic unit injectors use DC voltage. The ECM sends this voltage to the electronic unit injectors. Do not come in contact with the harness connector for the electronic unit injectors while the engine is operating. Failure to follow this instruction could result in personal injury or death.

This engine has a comprehensive, programmable Engine Monitoring System. The Electronic Control Module (ECM) will monitor the engine operating conditions. If any of the engine parameters extend outside an allowable range, the ECM will initiate an immediate action.

The following actions are available for engine monitoring control:

- Warning
- Derate
- Shutdown

The following monitored engine operating conditions and components have the ability to limit engine speed and/or the engine power:

- Engine Coolant Temperature
- Engine Oil Pressure
- Intake Manifold Air Temperature
- Intake Manifold Air Pressure
- Engine Speed Sensors
- Fuel Temperature
- Aftertreatment Temperature Sensors
- Diesel Particulate Filter (DPF) pressure sensor
- Electronic Unit Injectors
- Throttle Valve
- Supply Voltage to Sensors
- Fuel Pressure in Manifold (Rail)
- NOx Reduction System
- Engine Aftertreatment System

The Engine Monitoring package can vary for different engine models and different engine applications. However, the monitoring system and the engine monitoring control will be similar for all engines.

Note: Many of the engine control systems and display modules that are available for Perkins Engines will work in unison with the Engine Monitoring System. Together, the two controls will provide the engine monitoring function for the specific engine application. Refer to the Troubleshooting for more information on the Engine Monitoring System.

Product Information Section

General Information

i09869645

Model View Illustrations

The following model views show typical features of the engine and the aftertreatment system. Due to individual applications, your engine, and your aftertreatment may appear different from the illustrations.

Three Cylinder Engine

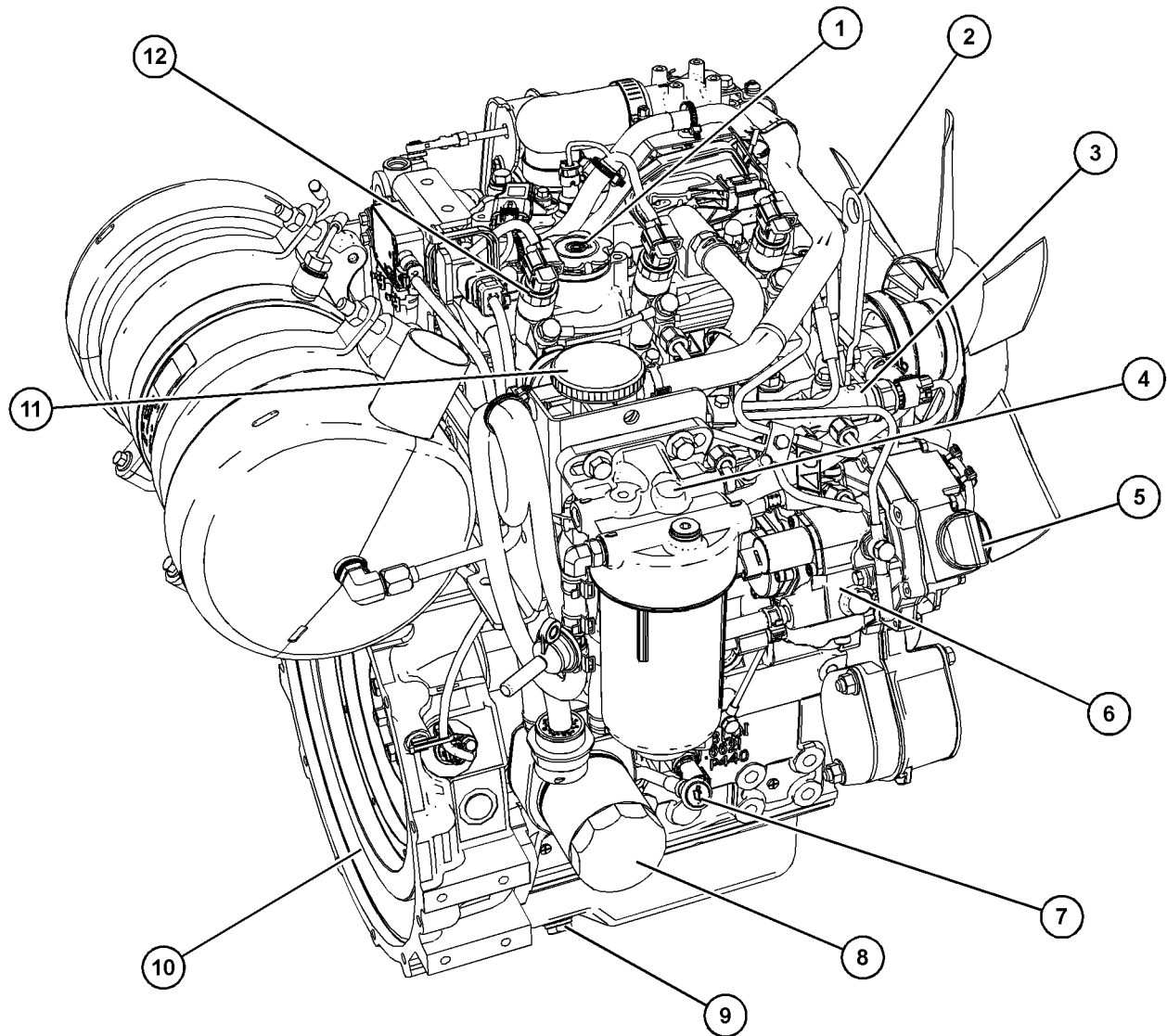

Illustration 32

g06783761

Typical example of a three cylinder engine with closed crankcase breather

- | | | |
|---|--------------------------|---|
| (1) Top oil fill cap | (5) Lower oil filler cap | (10) Flywheel |
| (2) Front lifting eye | (6) Fuel injection pump | (11) Crankcase breather element housing |
| (3) Fuel manifold (rail) | (7) Oil gauge (dipstick) | (12) Electronic unit injector |
| (4) Typical location of fuel filter for shipment only | (8) Oil filter | |
| | (9) Oil drain plug | |

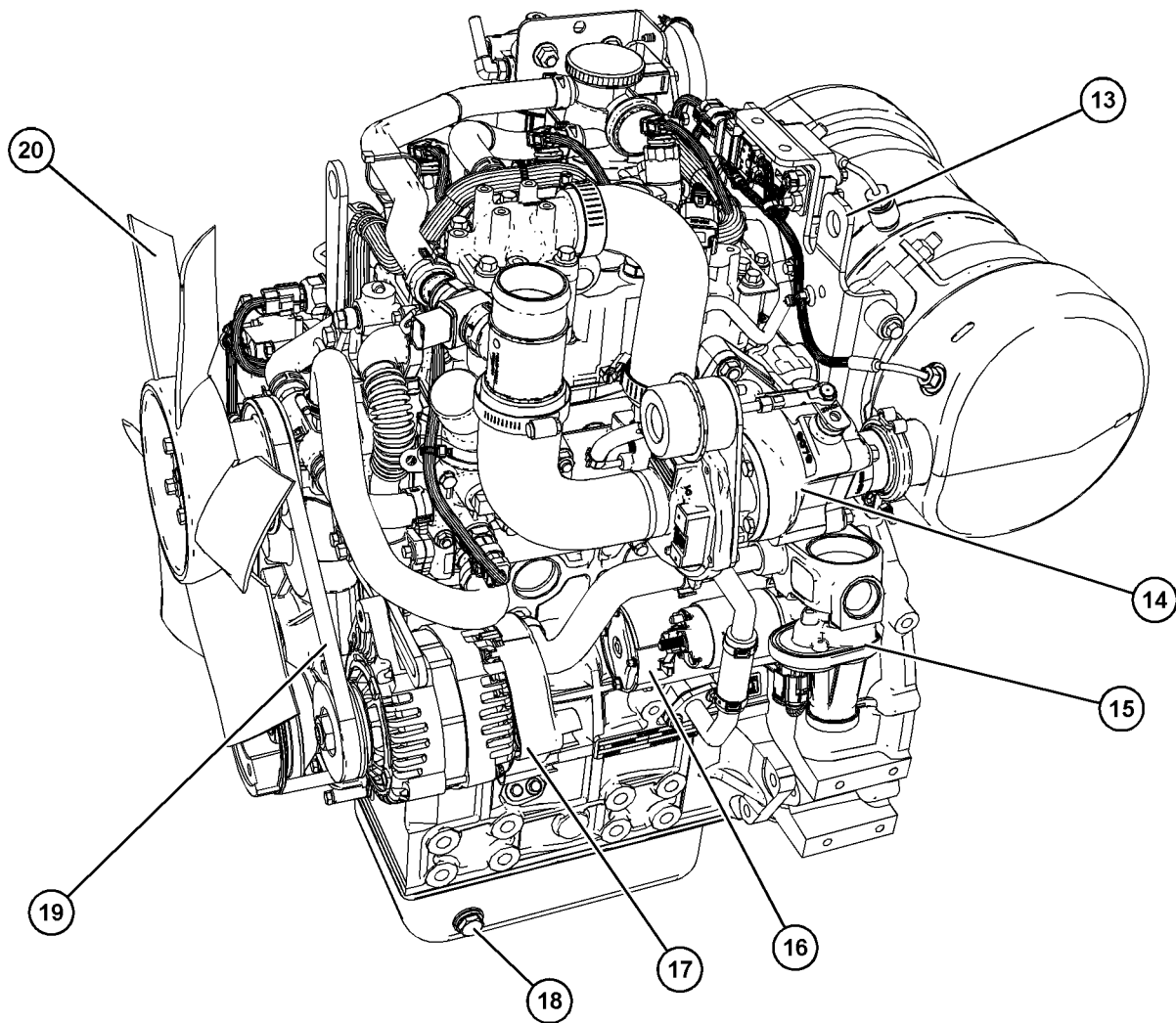

Illustration 33

g06783771

Typical example of a three cylinder engine with closed crankcase breather

(13) Rear lifting eye

(14) Turbocharger

(15) NOx Reduction System (NRS) Valve

(16) Starting motor

(17) Alternator

(18) Oil drain plug

(19) Alternator and fan belt

(20) Fan

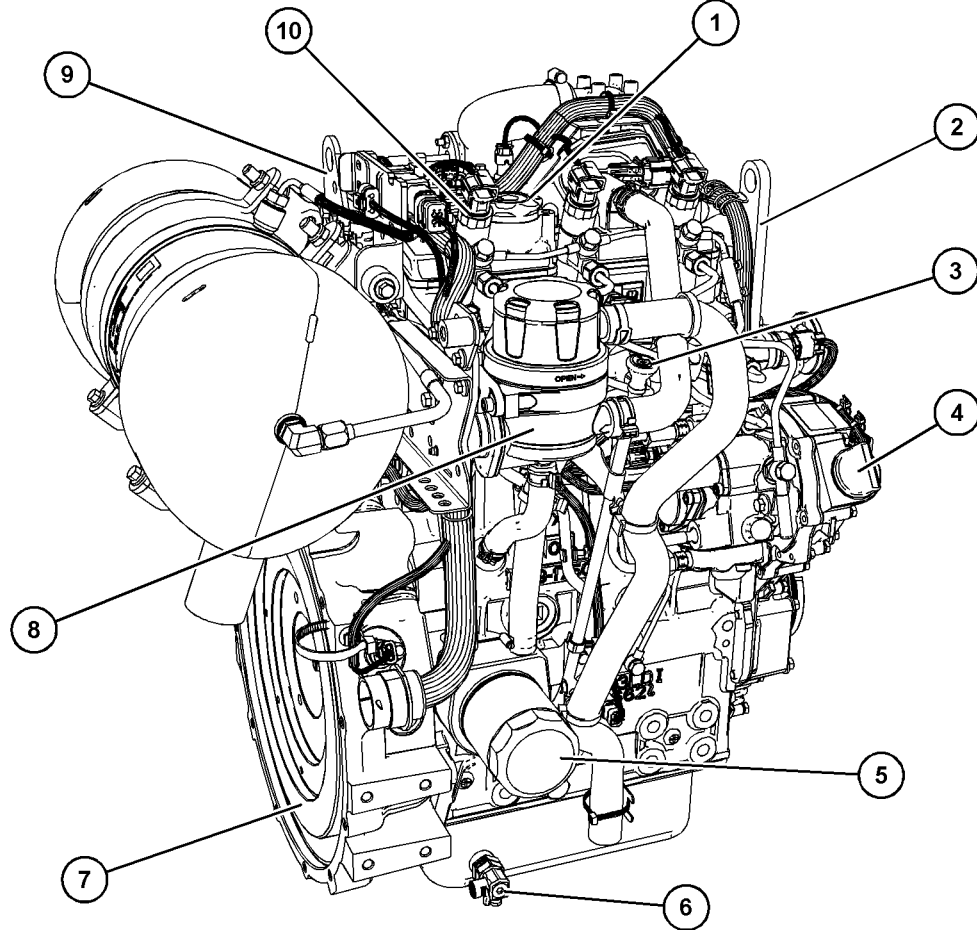

Illustration 34

g06783524

Typical example of a 3 cylinder engine with an open crankcase breather

- | | | |
|--------------------------|--|-------------------------------|
| (1) Top oil fill cap | (5) Oil filter | (9) Rear lifting eye |
| (2) Front lifting eye | (6) Oil drain tap (if equipped) | (10) Electronic unit injector |
| (3) Oil gauge (dipstick) | (7) Flywheel | |
| (4) Lower oil filler cap | (8) Crankcase breather element housing | |

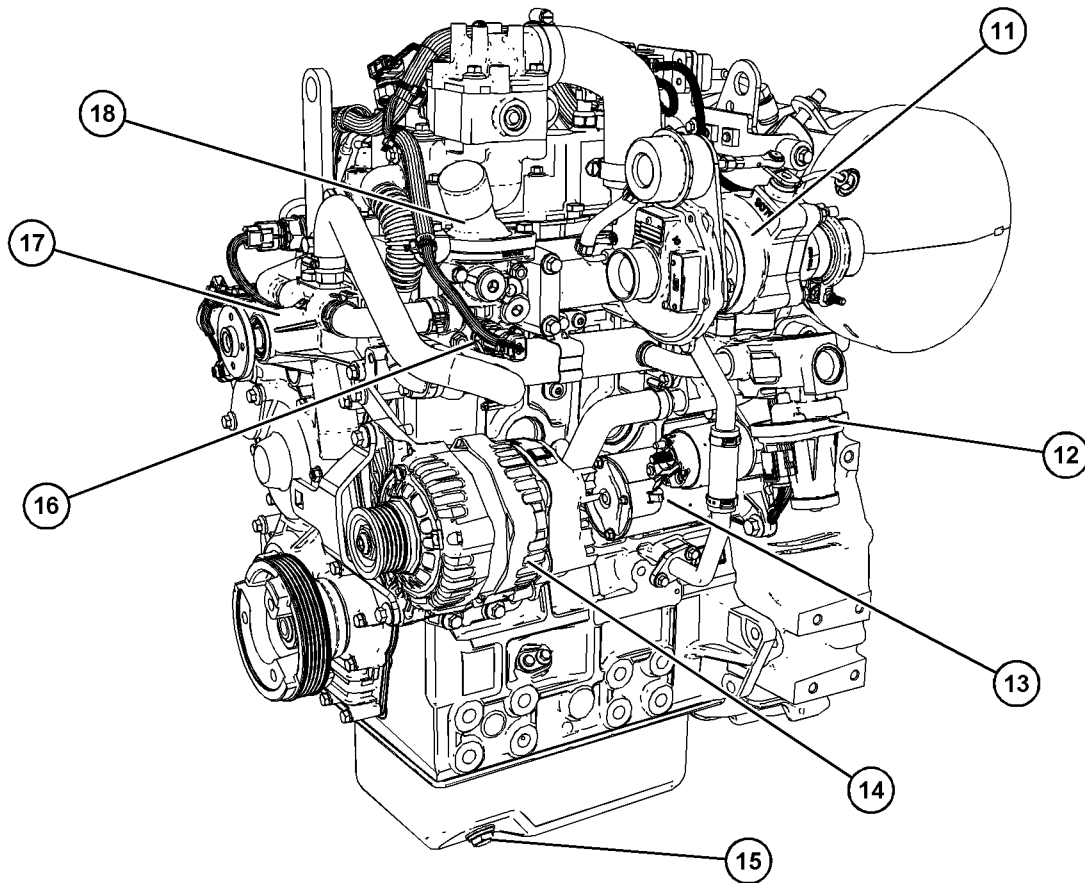

Illustration 35

g06783531

Typical example of a 3 cylinder engine with an open crankcase breather

- | | | |
|---------------------------------------|---------------------------------|--|
| (11) Turbocharger | (14) Alternator | (17) Water pump |
| (12) NOx Reduction System (NRS) Valve | (15) Oil drain plug | (18) Water temperature regulator housing |
| (13) Starting motor | (16) Coolant temperature sensor | |

Four Cylinder Engine

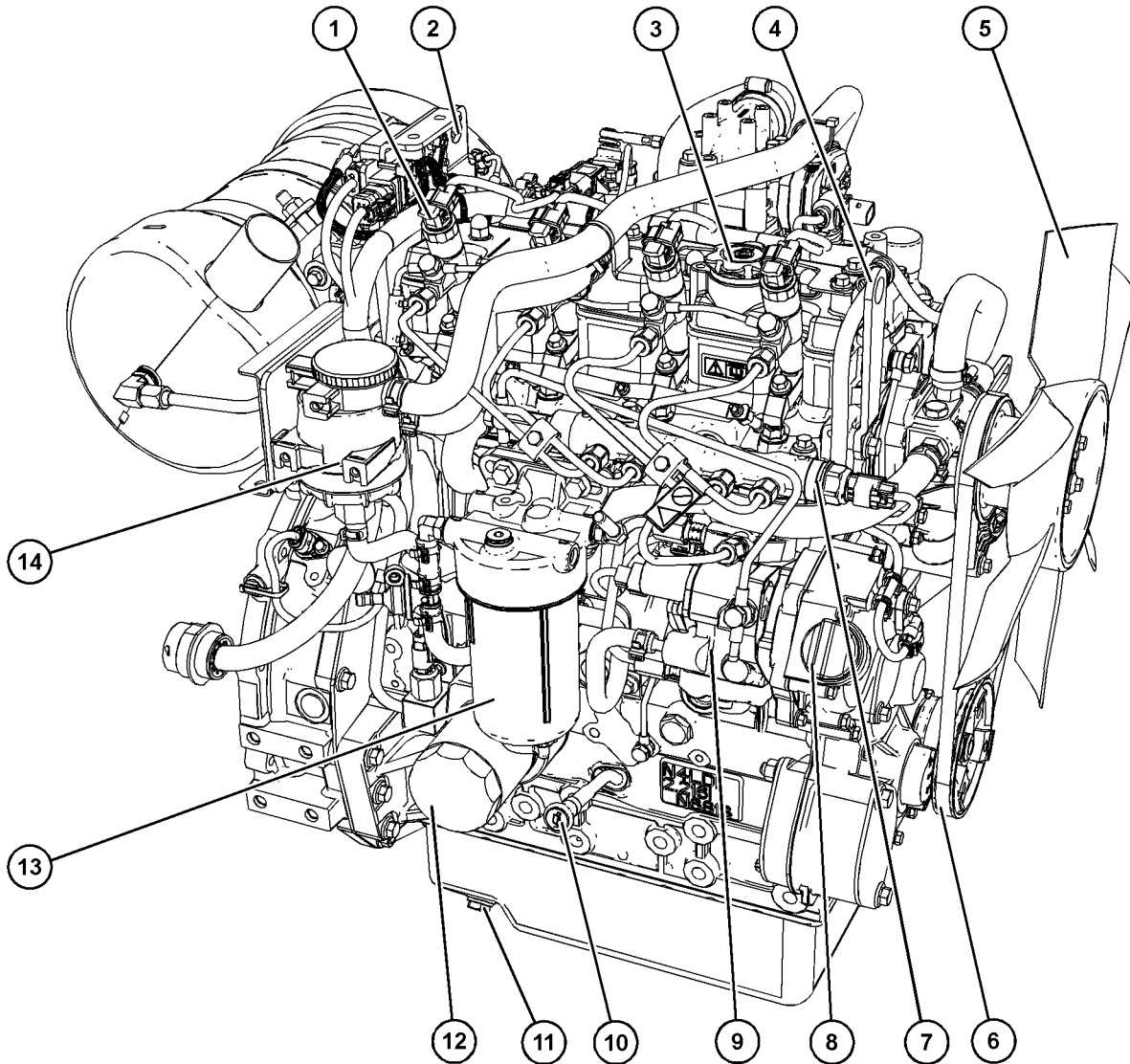

Illustration 36

g06310812

Typical example of a 4 cylinder engine with a closed crankcase breather

- | | | |
|------------------------------|-----------------------------|--------------------------------|
| (1) Electronic unit injector | (6) Alternator and fan belt | (11) Oil drain plug |
| (2) Rear lifting eye | (7) Fuel manifold (rail) | (12) Oil filter |
| (3) Top oil fill cap | (8) Lower oil filler cap | (13) Secondary fuel filter |
| (4) Front lifting eye | (9) Fuel injection pump | (14) Closed crankcase breather |
| (5) Fan | (10) Oil gauge (dipstick) | |

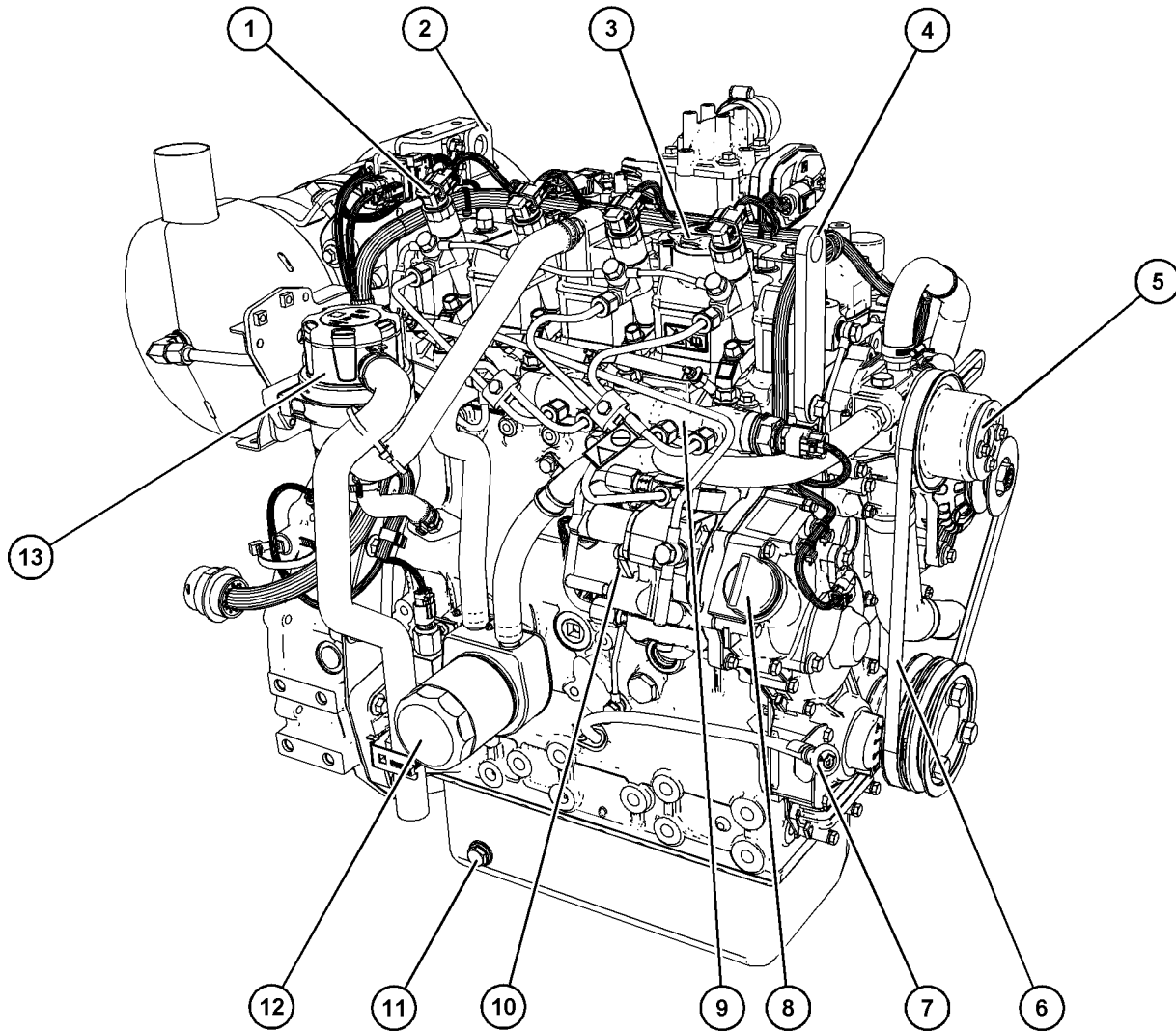

Illustration 37

g06772497

Typical example of a 4 cylinder engine with an open crankcase breather

- | | | |
|------------------------------|-----------------------------|------------------------------|
| (1) Electronic unit injector | (6) Alternator and fan belt | (11) Oil drain plug |
| (2) Rear lifting eye | (7) Oil gauge (dipstick) | (12) Oil filter |
| (3) Top oil fill cap | (8) Lower oil filler cap | (13) Open crankcase breather |
| (4) Front lifting eye | (9) Fuel manifold (rail) | |
| (5) Fan | (10) Fuel injection pump | |

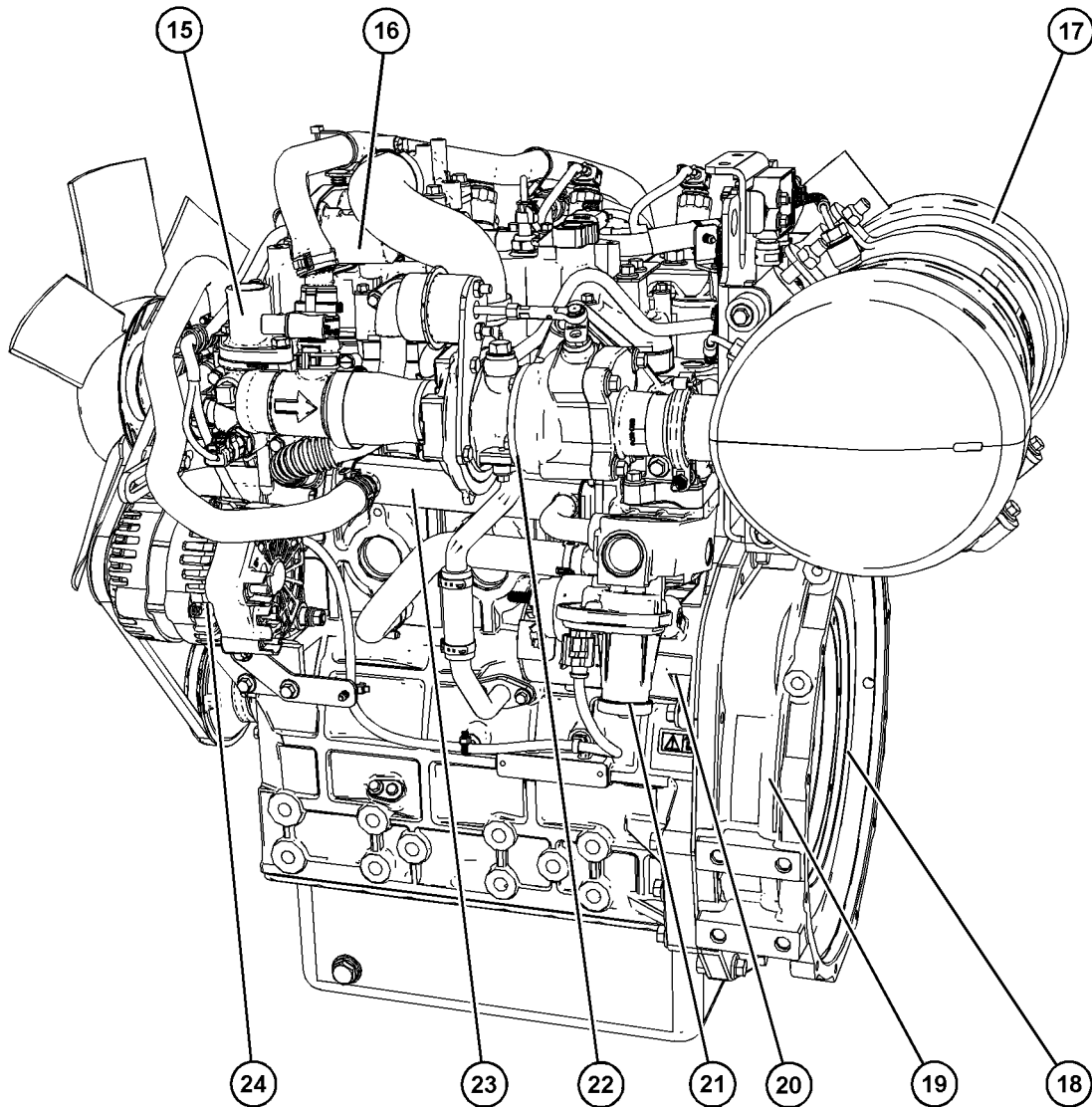

Illustration 38

g06311071

Typical example of a four cylinder engine with closed crankcase breather

- | | | |
|-----------------------------------|---------------------------------------|-----------------|
| (15) Water temperature regulator | (19) Flywheel housing | (23) NRS cooler |
| (16) Throttle valve | (20) Starting motor | (24) Alternator |
| (17) Clean Emissions Module (CEM) | (21) NOx Reduction System (NRS) Valve | |
| (18) Flywheel | (22) Turbocharger | |

Industrial Engine Views For Engines Equipped With A Balancer

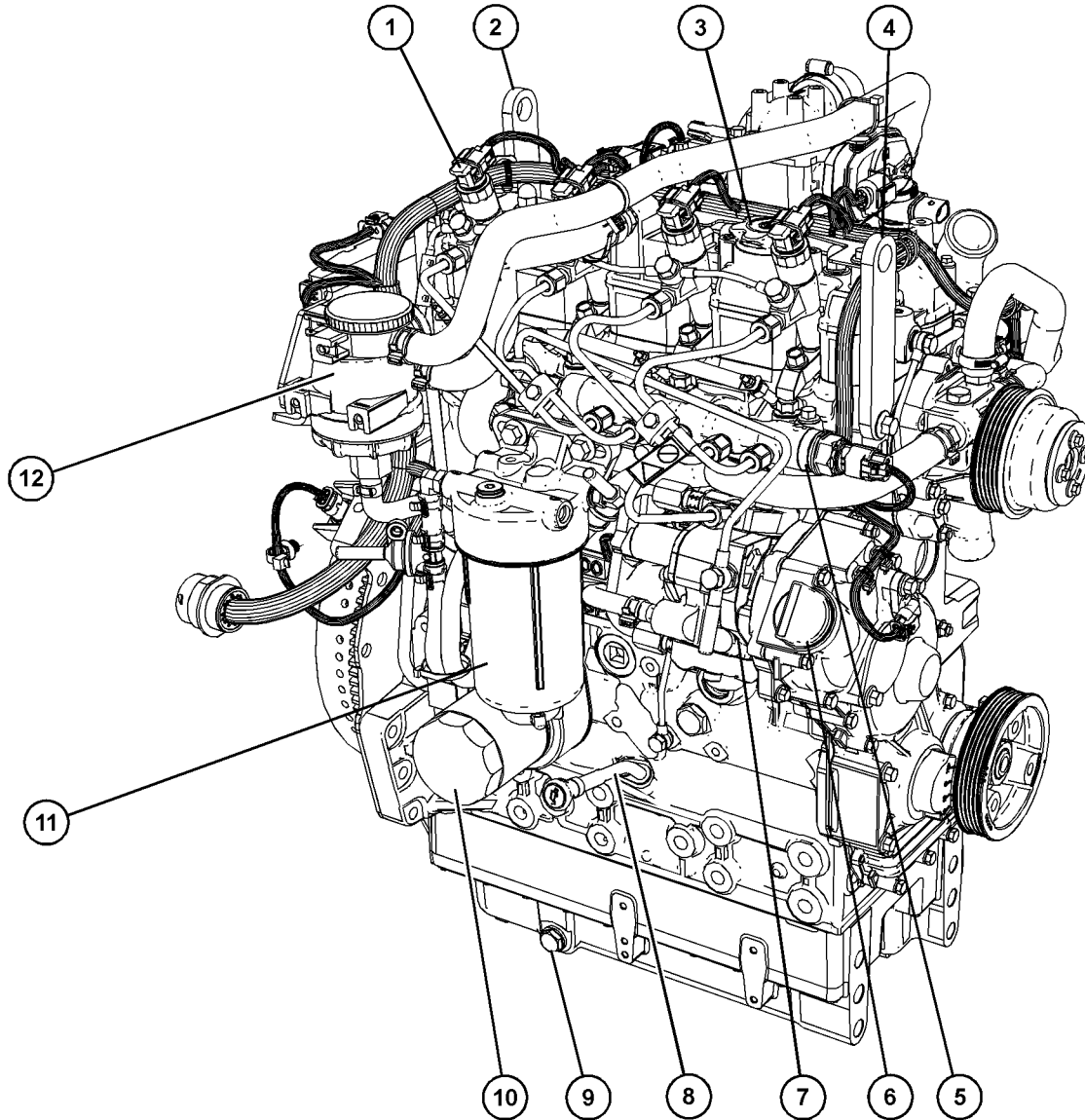

Illustration 39

g06543948

Typical example of a 4 cylinder engine with a closed crankcase breather

- (1) Electronic unit injector
- (2) Rear lifting eye
- (3) Top oil fill cap
- (4) Front lifting eye

- (5) Fuel manifold (rail)
- (6) Lower oil filler cap
- (7) Fuel injection pump
- (8) Oil gauge (dipstick)

- (9) Oil drain plug
- (10) Oil filter
- (11) Secondary fuel filter
- (12) Open crankcase breather

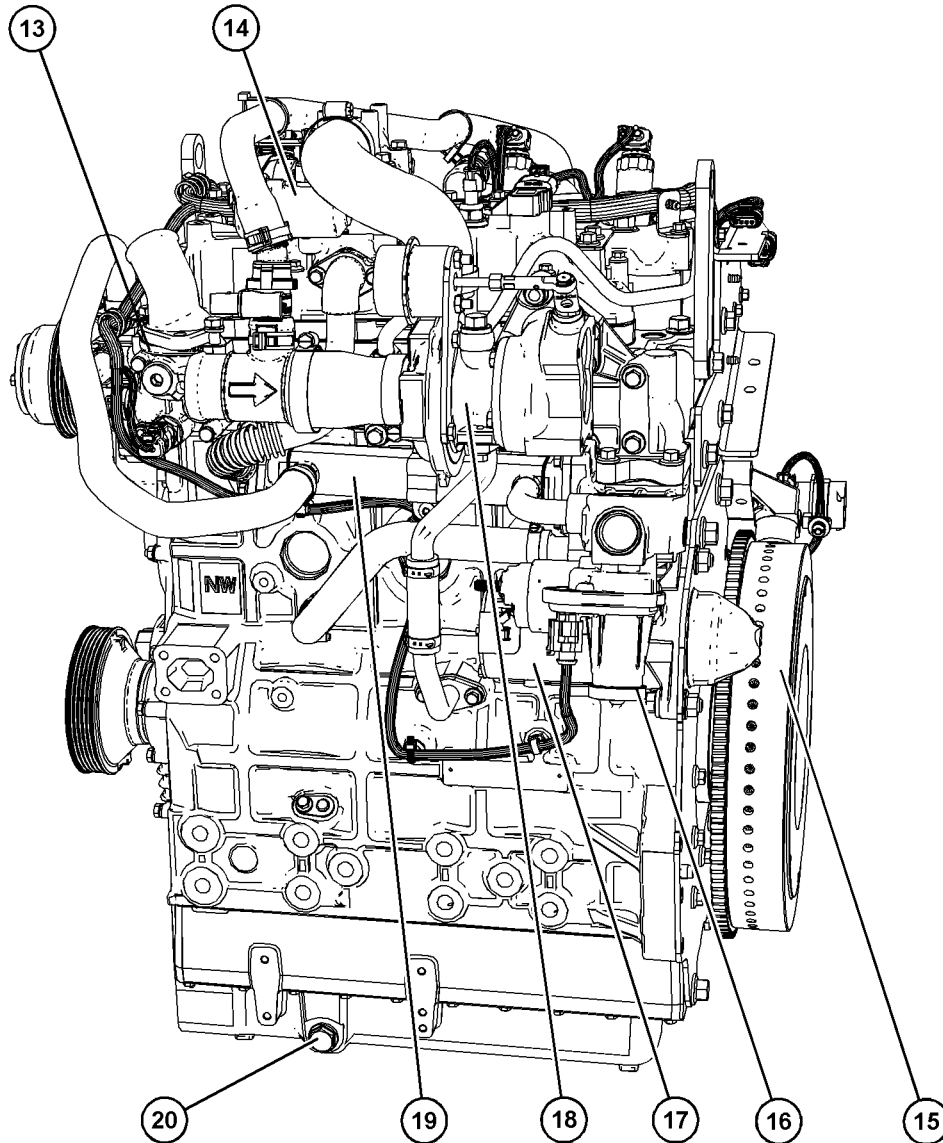

Illustration 40

g06543949

Typical example of a 4 cylinder engine with a closed crankcase breather

(13) Water temperature regulator
 (14) Throttle valve
 (15) Flywheel

(16) NOx Reduction System (NRS) Valve
 (17) Starting motor
 (18) Turbocharger

(19) NRS cooler
 (20) Oil drain plug

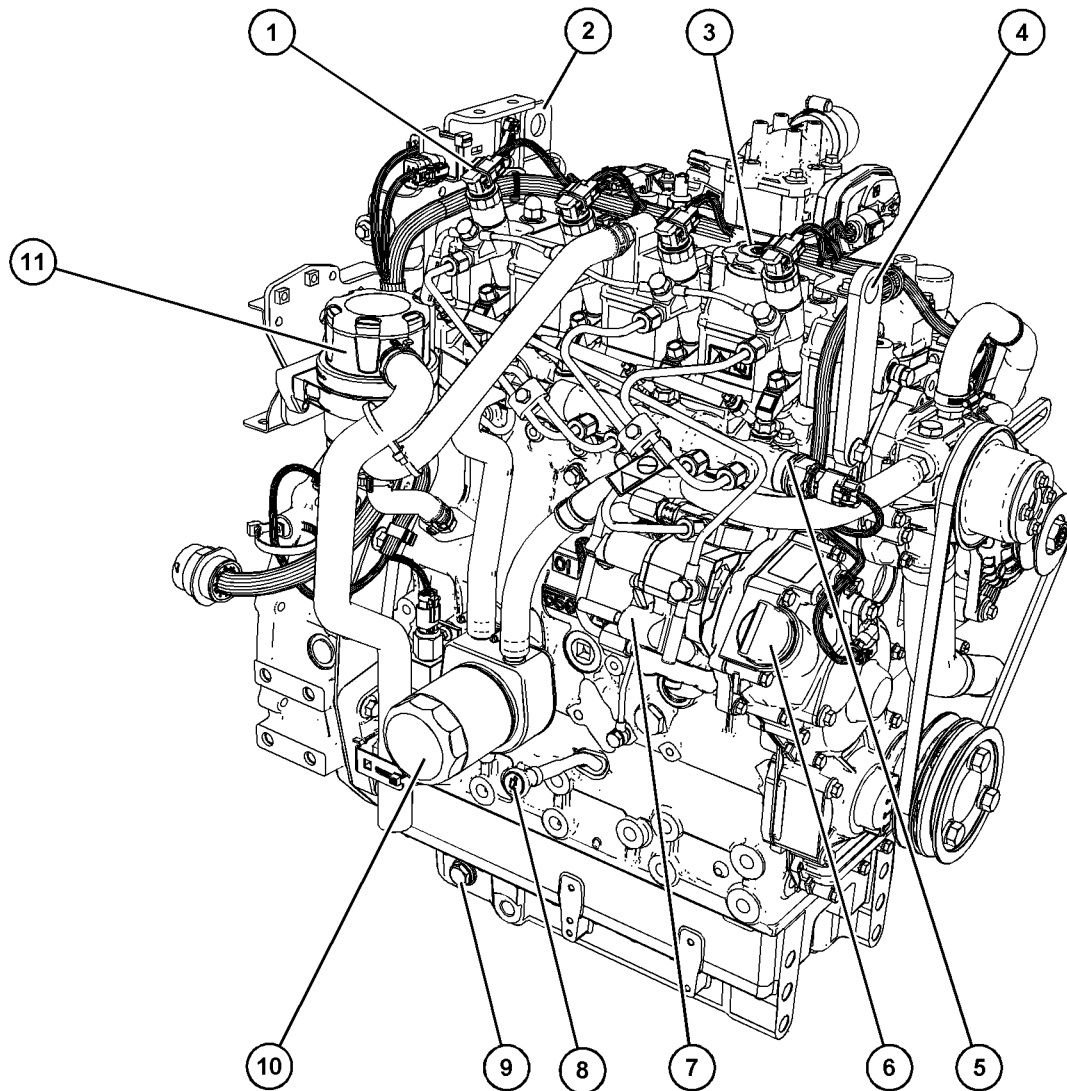

Illustration 41

g06772581

Typical example of a 4 cylinder engine with an open crankcase breather

- | | | |
|------------------------------|--------------------------|------------------------------|
| (1) Electronic unit injector | (5) Fuel manifold (rail) | (9) Oil drain plug |
| (2) Rear lifting eye | (6) Lower oil filler cap | (10) Oil filter |
| (3) Top oil fill cap | (7) Fuel injection pump | (11) Open crankcase breather |
| (4) Front lifting eye | (8) Oil gauge (dipstick) | |

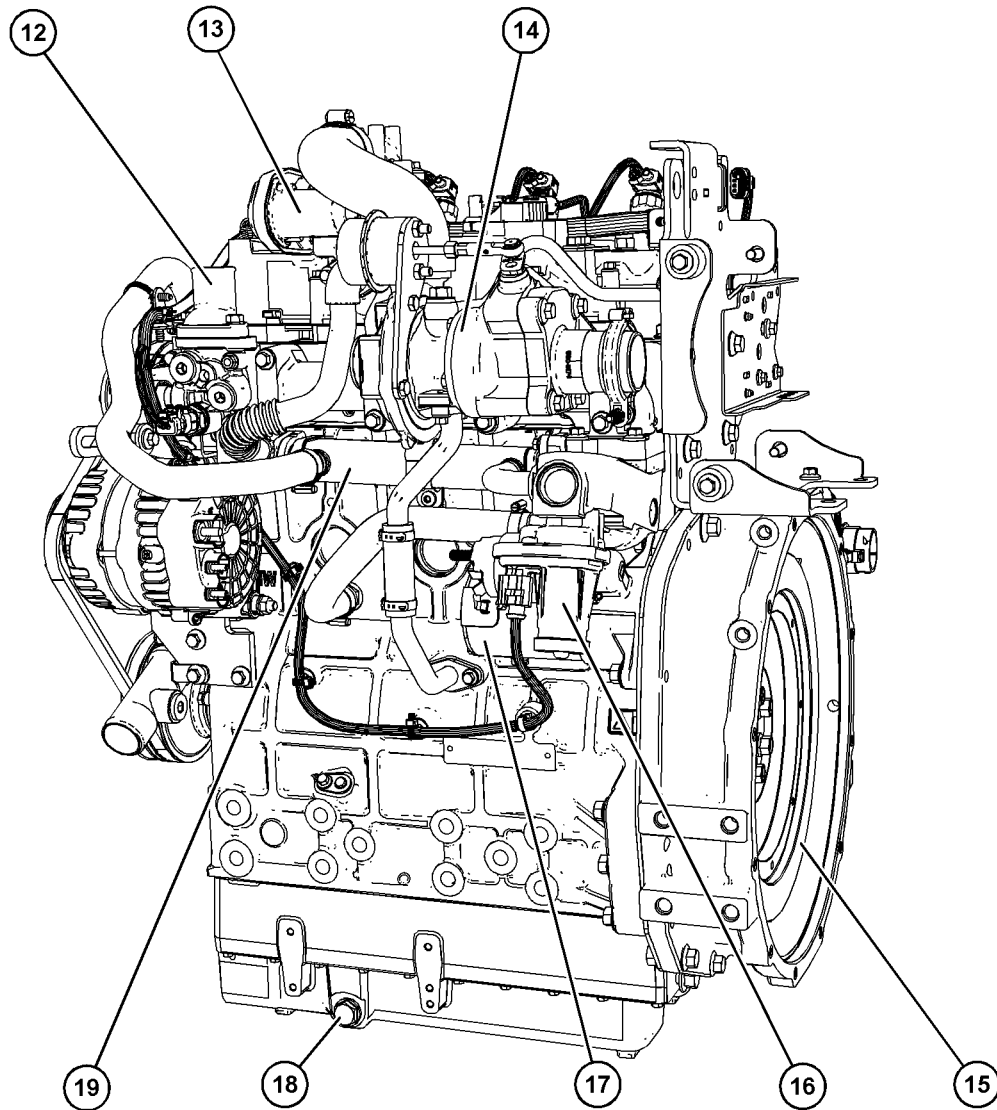

Illustration 42

g06772585

Typical example of a 4 cylinder engine with an open crankcase breather

(12) Water temperature regulator
 (13) Throttle valve
 (14) Turbocharger

(15) Flywheel
 (16) NOx Reduction System (NRS) Valve
 (17) Starting motor

(18) Oil drain plug
 (19) NRS cooler

Off Engine Components for Three and Four Cylinder Engines

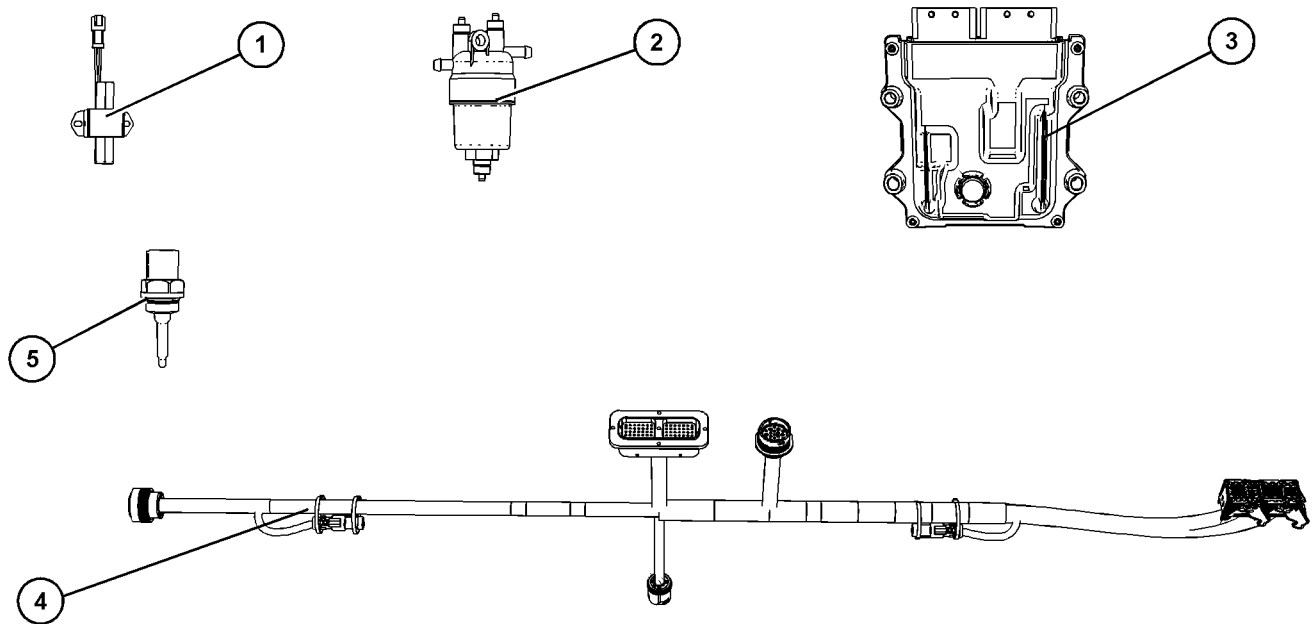

Illustration 43

g06444151

Typical example

(1) Electric fuel priming pump

(2) Primary fuel filter/water separator

(3) Electronic Control Module (ECM)

(4) Engine link wiring harnesses

(5) Inlet air temperature sensor

Industrial Open Power Unit (IOPU)

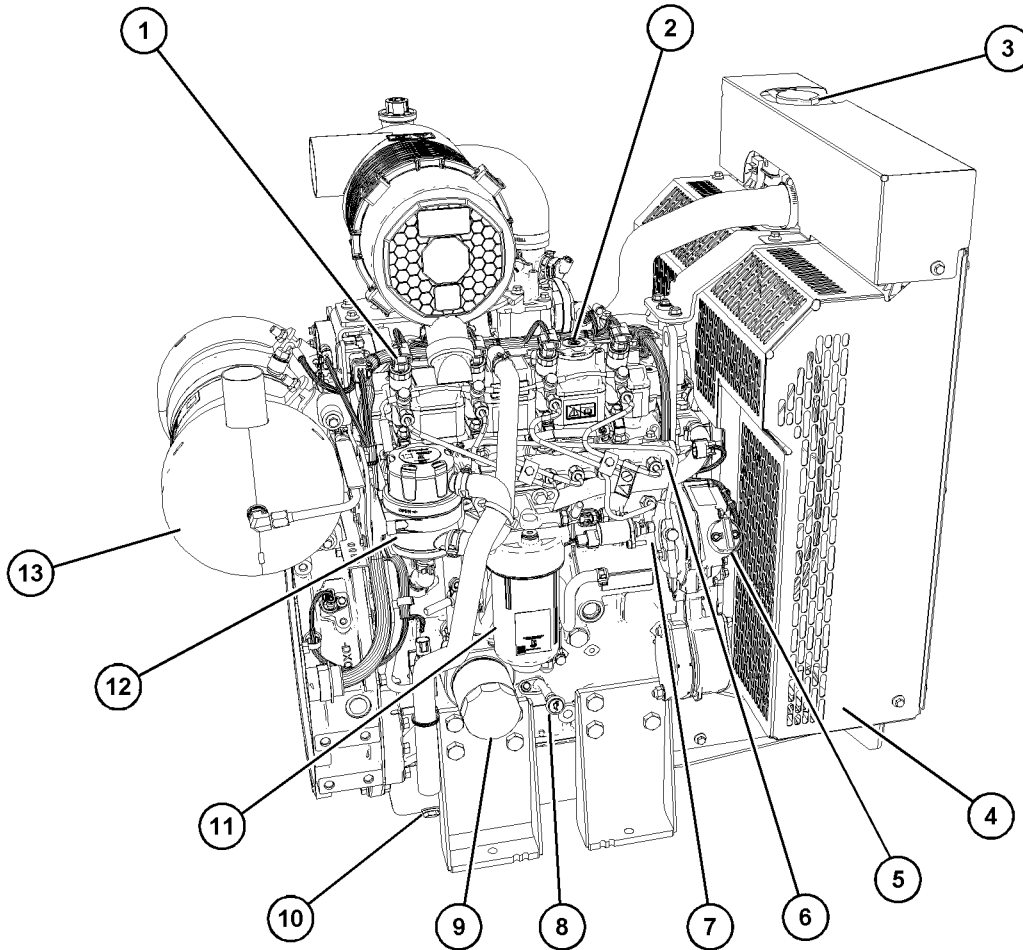

Illustration 44

g07522501

Typical example of a 4 cylinder IOPU

- | | | |
|---------------------------------|--------------------------|--|
| (1) Electronic unit injector | (6) Fuel manifold (rail) | (11) Secondary fuel filter/water separator |
| (2) Top oil fill cap | (7) Fuel injection pump | (12) Open crankcase breather |
| (3) Radiator coolant refill cap | (8) Oil gauge (dipstick) | (13) Clean Emissions Module (CEM) |
| (4) Fan guard | (9) Oil filter | |
| (5) Lower oil filler cap | (10) Oil drain plug | |

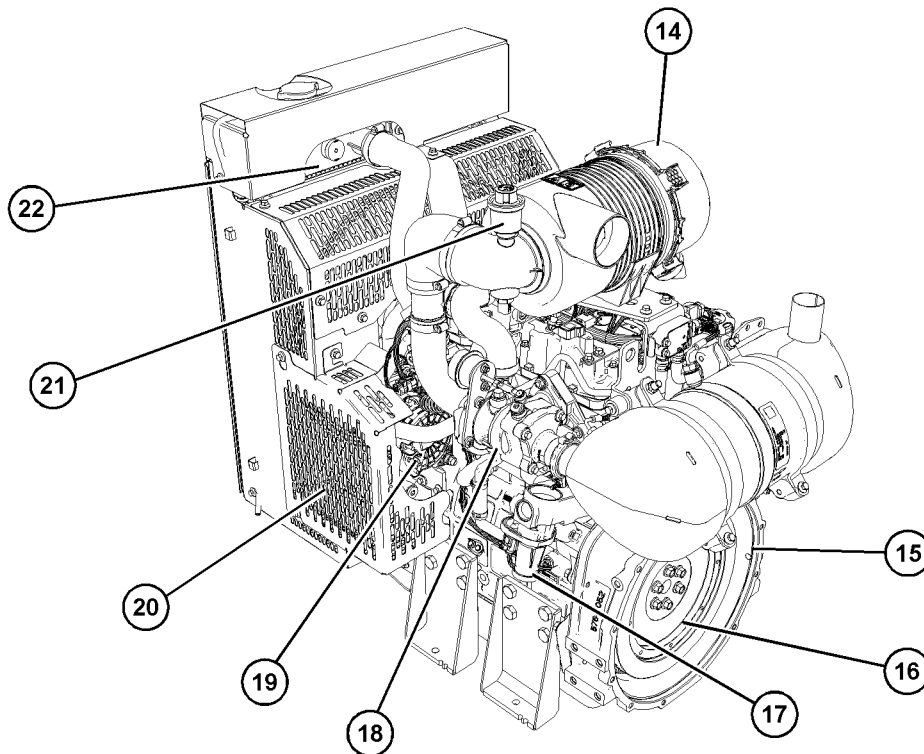

Illustration 45

g07522507

Typical example of a 4 cylinder IOPU

(14) Engine air cleaner
 (15) Flywheel housing
 (16) Flywheel

(17) NOx Reduction System (NRS) Valve
 (18) Turbocharger
 (19) Alternator

(20) Service panel
 (21) Engine air cleaner service indicator
 (22) Radiator

Electropak

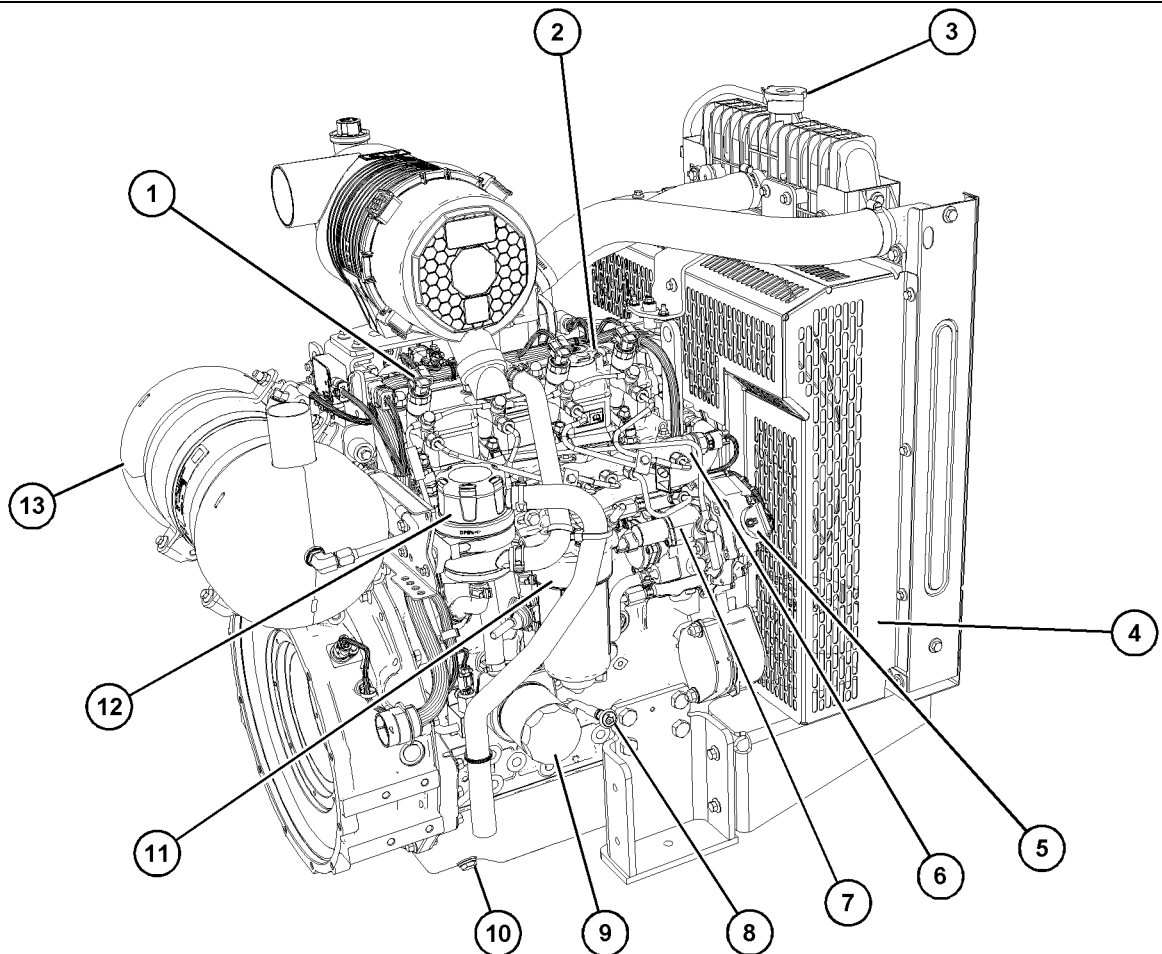

Illustration 46

g07626377

Typical example of an Electropak

- | | | |
|---------------------------------|--------------------------|--|
| (1) Electronic unit injector | (6) Fuel manifold (rail) | (11) Secondary fuel filter/water separator |
| (2) Top oil fill cap | (7) Fuel injection pump | (12) Open crankcase breather |
| (3) Radiator coolant refill cap | (8) Oil gauge (dipstick) | (13) Clean Emissions Module (CEM) |
| (4) Fan guard | (9) Oil filter | |
| (5) Lower oil filler cap | (10) Oil drain plug | |

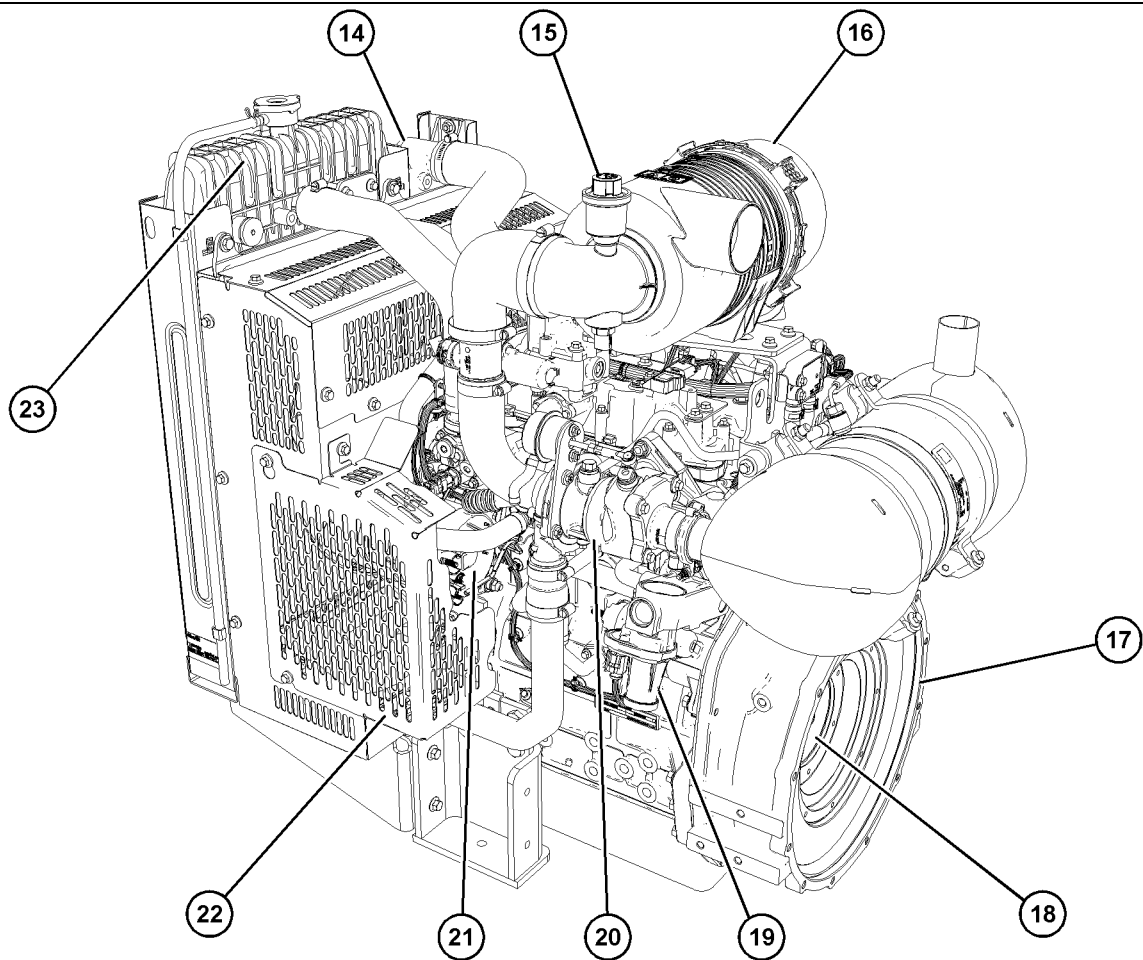

Illustration 47

g07626399

Typical example of an Electropak

- | | | |
|---|---------------------------------------|--------------------|
| (14) Aftercooler | (18) Flywheel | (22) Service panel |
| (15) Engine air cleaner service indicator | (19) NOx Reduction System (NRS) Valve | (23) Radiator |
| (16) Engine air cleaner | (20) Turbocharger | |
| (17) Flywheel housing | (21) Alternator | |

Off Engine Components for Three or Four Cylinder IOPU and ElectropaK

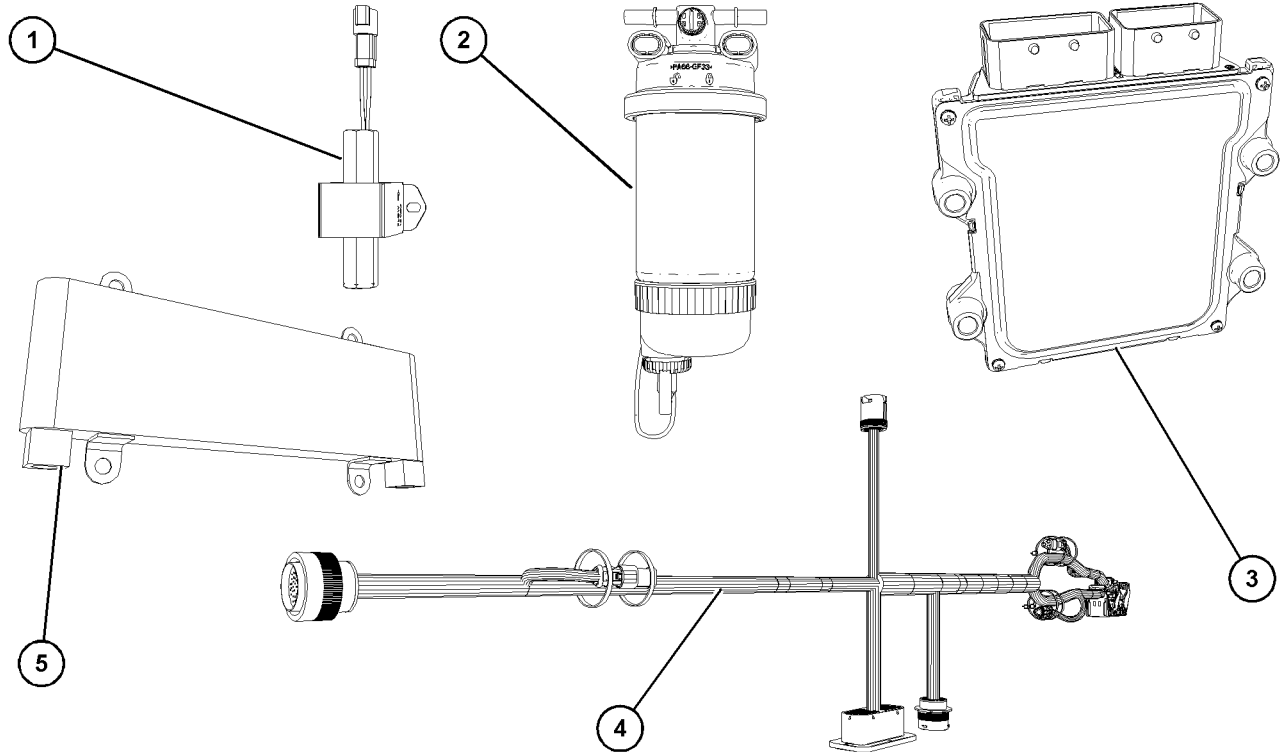

Illustration 48

g07522512

Typical example

- | | | |
|---|-------------------------------------|-----------------|
| (1) Electric fuel priming pump | (3) Electronic Control Module (ECM) | (5) Fuel cooler |
| (2) Primary fuel filter/water separator | (4) Engine link wiring harnesses | |

i08108619

Product Description

Three Cylinder Engine 403J-E17T

The 403J-E17T industrial engine is a turbocharged engine. The engine is electronically governed.

The 403J-E17T industrial engine has the following characteristics.

- In-line 3 cylinder
- 4 stroke cycle
- Two valves per cylinder

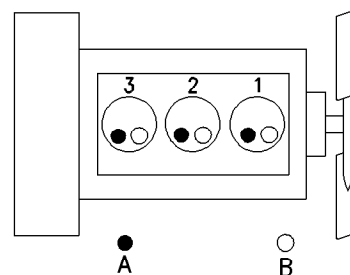

Illustration 49

g00852304

- (A) Exhaust valves
(B) Inlet valves

Table 1

403J-E17T Engine Specifications	
Maximum Operating Speed (rpm)	2800 RPM
Cylinders and Arrangement	In-Line three cylinder engine
Bore	84 mm (3.31 inch)
Stroke	100 mm (3.94 inch)
Displacement	1.66 L (101.3 in ³)
Aspiration	Turbocharged
Compression Ratio	17:1
Firing Order	1-2-3
Rotation (flywheel end)	Counterclockwise
Valve Lash Setting (Inlet)	0.20 mm (0.008 inch)
Valve Lash Setting (Exhaust)	0.20 mm (0.008 inch)

Four Cylinder Engine 404J-E22T and 404J-E22TA

Two variants of 404J-E22T and 404J-E22TA industrial engine are available, the turbocharged engine and the turbocharged charge cooled engine. Both engine variants are electronically governed.

The 404J-E22T and 404J-E22TA industrial engines have the following characteristics.

- In-line 4 cylinder
- 4 stroke cycle
- Two valves per cylinder

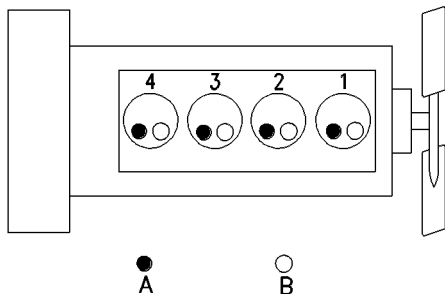

Illustration 50

g00296424

(A) Exhaust valves
(B) Inlet valves

Table 2

404J-E22T and 404J-E22TA Industrial Engines	
Maximum Operating Speed (rpm)	2800 RPM
Cylinders and Arrangement	In-Line four cylinder engine
Bore	84 mm (3.307 inch)
Stroke	100 mm (3.937 inch)
Displacement	2.216 L (135.2 cubic inch)
Compression Ratio	17: 1
Aspiration	Turbocharged and Turbo-charged charge/air cooled
Valve Lash Setting (Inlet)	0.20 mm (0.008 inch)
Valve Lash Setting (Exhaust)	0.20 mm (0.008 inch)
Firing Order	1-3-4-2
Rotation (flywheel end)	Counterclockwise

Engines Equipped with a Balancer

The engines that are equipped with a balancer have support pads on the oil pan.

The maximum weight that the oil pan support pads can be subjected to a :

- Combined uniform distributed load on front pads of 912 kg (2010 lb)
- Combined uniform distributed load on rear pads of 386 kg (851 lb)

Refer to Product Lifting for more information.

Aftertreatment System

Both the three and four cylinder engines have the same aftertreatment system.

The aftertreatment system is approved for use by Perkins. To be emission-compliant, only the approved Perkins aftertreatment system must be used on a Perkins engine.

Clean Emission Module (CEM)

The CEM comprises of two main components in a single unit, the Diesel Oxidation Catalyst (DOC) and the Diesel Particulate Filter (DPF). The function of the CEM is to ensure that the engine exhaust meets the required emissions regulation for the country of operation.

The exhaust gases pass through the DOC to remove contaminants, carbon monoxide, and hydrocarbons. The exhaust gases then enter the DPF where any particulate matter soot and ash will be trapped.

The CEM uses a passive and active regeneration process to ensure that normal operation of the engine removes the soot. The soot is removed at an equal rate of which the soot is captured. The ash remains in the DPF.

Electronic Engine Features

The engine operating conditions are monitored. The Electronic Control Module (ECM) controls the response of the engine to these conditions and to the demands of the operator. These conditions and operator demands determine the precise control of fuel injection by the ECM. The electronic engine control system provides the following features:

- Engine monitoring
- Engine speed governing
- Injection timing control
- System diagnostics

Engine Diagnostics

The engine has built-in diagnostics to ensure that the engine systems are functioning correctly. The operator will be alerted to the condition by a “Stop” or “Warning” lamp. Under certain conditions, the engine horsepower, the engine speed, and the vehicle speed may be limited. The electronic service tool may be used to display the diagnostic codes.

There are four types of diagnostic codes: Active Diagnostic Code, Logged Diagnostic Code, Active Event Code, and Logged Event Code.

The ECM provides an electronic governor that controls the injector output to maintain the desired engine RPM.

Service Life

Engine efficiency and maximum utilization of engine performance depend on the adherence to proper operation and maintenance recommendations. In addition, use recommended fuels, coolants, and lubricants. Use the Operation and Maintenance Manual as a guide for required engine maintenance.

Expected engine life is generally predicted by the average power that is demanded. The average power that is demanded is based on fuel consumption of the engine over a period of time. Reduced hours of operation at full throttle and/or operating at reduced throttle settings result in a lower average power demand.

The aftertreatment system can be expected to function properly for the useful life of the engine (emissions durability period), as defined by regulation, subject to prescribed maintenance requirements being followed.

Aftermarket Products and Perkins Engines

Perkins does not warrant the quality or performance of non-Perkins fluids and filters.

When auxiliary devices, accessories, or consumables (filters, additives, catalysts), which are made by other manufacturers are used on Perkins products, the Perkins warranty is not affected simply because of such use.

However, failures that result from the installation or use of other manufacturers devices, accessories, or consumables are NOT Perkins defects. Therefore, the defects are NOT covered under the Perkins warranty.

Product Identification Information

i07398917

Plate Locations and Film Locations

Serial Number Plate

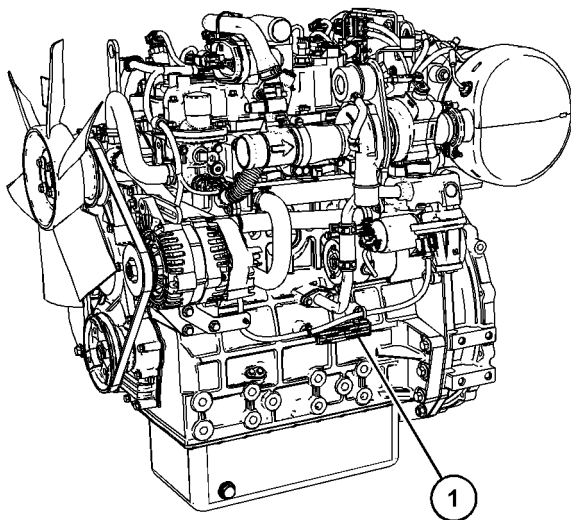

Illustration 51
Typical example

The engine serial plate (1) is on the left side of the engine to the rear of the engine cylinder block.

Perkins distributors need all the numbers on the plate to determine the components that were included with the engine. This information permits accurate identification of replacement part numbers.

Perkins Plate



Illustration 52
Typical example

g01094203

i07785792

Emissions Certification Film

EMISSION CONTROL INFORMATION	
Perkins®	PERKINS SMALL ENGINES LTD.
ENGINE FAMILY	#####
POWER CATEGORY	#####
DISPLACEMENT	##### L
EMISSION-CONTROL SYSTEM	IFI ECM
USEFUL LIFE DEFINED BY	CARB: 5 YEARS OR 3000h
DATE OF MANUFACTURE: #####	
THIS ENGINE CONFORMS TO 2013 U.S. EPA AND CALIFORNIA REGULATIONS FOR LARGE NON-ROAD STATIONARY COMPRESSION-IGNITION ENGINES	
ULTRA LOW SULFUR FUEL ONLY	
EC TYPE- APPROVAL No:	#####
#####	#####

Illustration 53
Typical example

g06435423

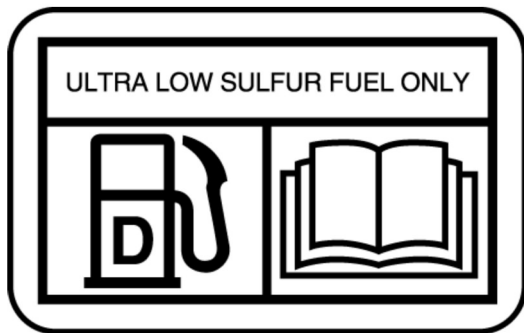

Illustration 54

g02157153

Typical example

Illustration 54 is a representation of the label that will be installed next to the fuel filler cap on the fuel tank of the application.

i06280422

Reference Information

Information for the following items may be needed to order parts. Locate the information for your engine. Record the information in the appropriate space. Make a copy of this list for a record. Keep the information for future reference.

Record for Reference

Engine Model _____

Engine Serial number _____

Engine Low Idle rpm _____

Engine Full Load rpm _____

Primary Fuel Filter _____

Secondary Fuel Filter Element _____

Lubrication Oil Filter Element _____

Auxiliary Oil Filter Element (if Equipped) _____

Total Lubrication System Capacity _____

Total Cooling System Capacity _____

Air Cleaner Element _____

Drive Belt _____

Operation Section

Lifting and Storage

i09872729

Product Lifting

NOTICE

Always inspect lifting eyebolts and all other lifting equipment for damage before performing any lifting. Never bend the eyebolts and the brackets. Never perform product lifting if components are damaged. Only load the eyebolts and the brackets under tension. Remember that the capacity of an eyebolt is less as the angle between the supporting members and the object becomes less than 90 degrees.

When it is necessary to remove a component at an angle, only use a link bracket that is properly rated for the weight.

Use a hoist to remove heavy components. Use an adjustable lifting beam to lift the engine. All supporting members (chains and cables) should be parallel to each other. The chains and cables should be perpendicular to the top of the object that is being lifted.

To obtain the correct balance for lifting an application, adjust the chain lengths.

Lifting eyes are designed and installed for the specific engine arrangement. Alterations to the lifting eyes and/or the engine make the lifting eyes and the lifting fixtures obsolete. If alterations are made, ensure that proper lifting devices are provided.

There are several different designs of lifting eyes. The following sections give examples of lifting eyes on the engine, engine, and aftertreatment and Industrial Open Power Unit (IOPU).

Consult your Perkins distributor for information regarding fixtures for proper lifting.

Engine and Aftertreatment

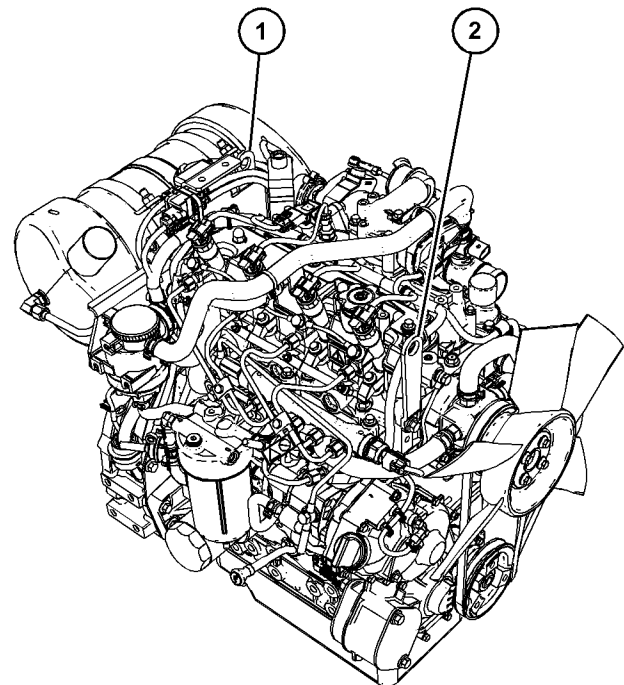

Illustration 55

g06310634

Lifting eyes for the engine and aftertreatment only

- (1) Rear lifting eye
- (2) Front lifting eye

Engine Equipped with a Balancer

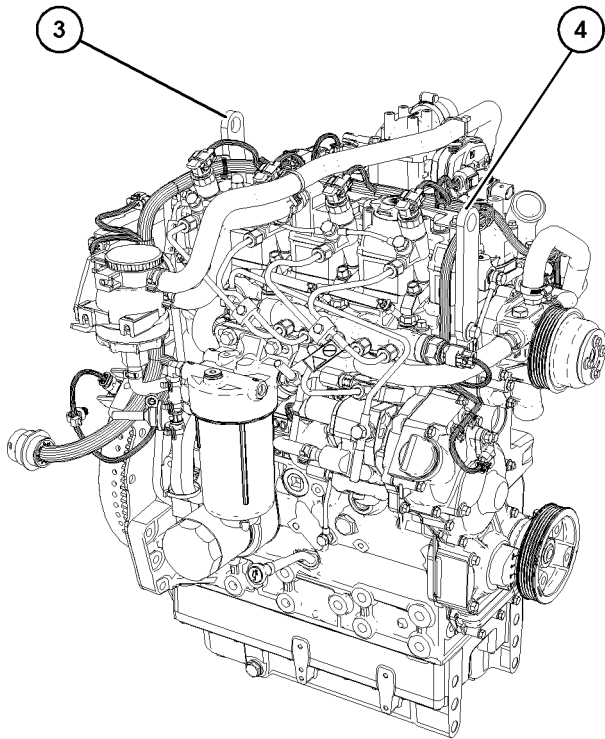

Illustration 56

g06545459

Lifting eyes for the engine only

- (3) Rear lifting eye
- (4) Front lifting eye

If the engine is removed and placed on a suitable engine stand, there are weight limitation for the support pads of the cast iron tunnel type engine oil pan.

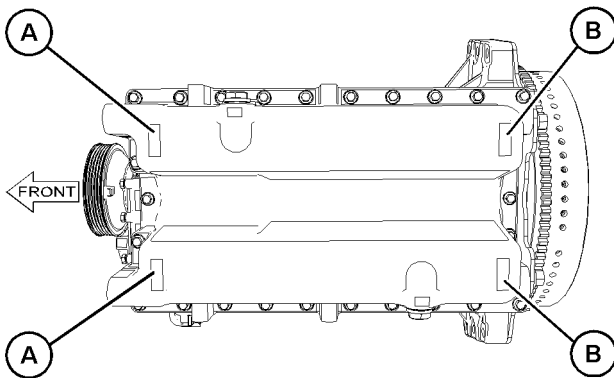

Illustration 57

g06564871

Engine support pad locations on the cast iron engine oil pan

- (A) Front support pads
- (B) Rear support pads

The support pads in Positions (A) can support a maximum evenly distributed load with a combined weight of 912 kg (2010 lb), refer to Illustration 57 .

The support pads in Positions (B) can support a maximum evenly distributed load with a combined weight of 386 kg (851 lb), refer to Illustration 57 .

Aftertreatment Systems for Engine Equipped with a Balancer

Ensure that the correct clothing is worn, refer to this Operation and Maintenance Manual, "General Hazard Information".

The approximate weight of the Aftertreatment is 13 kg (28.7 lb).

A minimum of two suitable double looped slings will be required to lift the Aftertreatment. Also, a suitable hoist will be required to remove and install the assembly.

The slings must be securely attached to the Aftertreatment in a manner that will enable safe removal.

Ensure that the slings only contact the body of the Aftertreatment. A test lift may be required to achieve the correct balance of the assembly for safe removal.

Some applications may require a frame or jig to lift the Aftertreatment. Only connect frame or jig to the cradle of the Aftertreatment. Refer to the Original equipment manufacture for more information.

Industrial Open Power Unit (IOPU)

NOTICE

Damage may occur to the engine air cleaner during the lifting of the IOPU. Perkins recommends that the engine air cleaner is removed before lifting the IOPU. Refer to Disassembly and Assembly Manual, "Air Cleaner Housing - Remove and Install".

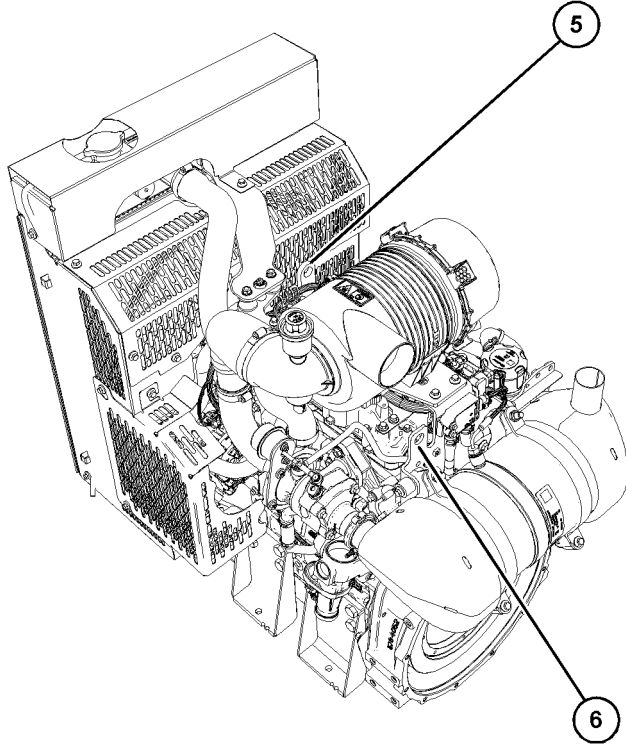

Illustration 58 g07521889

Typical example of lifting eyes for 4 cylinder IOPU

- (5) Front lifting eye
- (6) Rear lifting eye

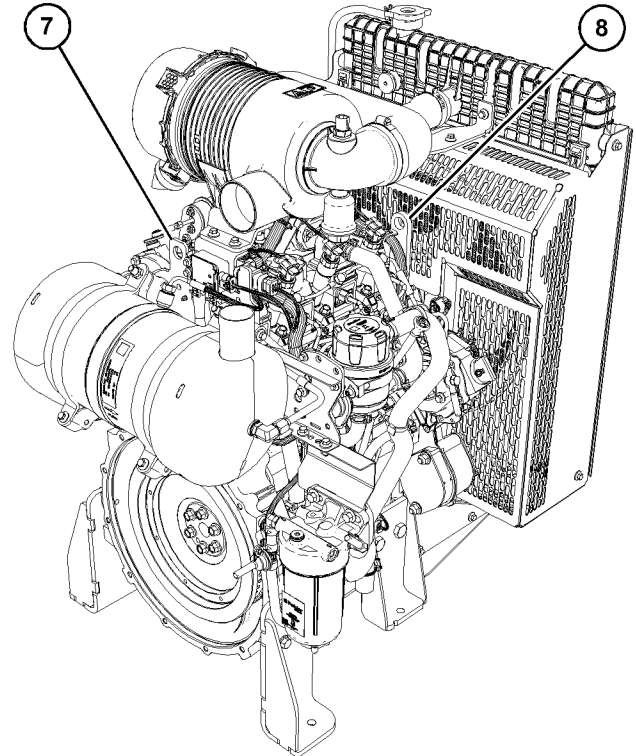

Illustration 59 g07521915

Typical example of lifting eyes for 3 cylinder IOPU

- (7) Rear lifting eye
- (8) Front lifting eye

Remove the engine air cleaner on both types of IOPU before attaching any lifting equipment.

ElectropaK

NOTICE

Damage may occur to the engine air cleaner during the lifting of the ElectropaK. Perkins recommends that the engine air cleaner is removed before lifting the ElectropaK. Refer to Disassembly and Assembly Manual, "Air Cleaner Housing - Remove and Install".

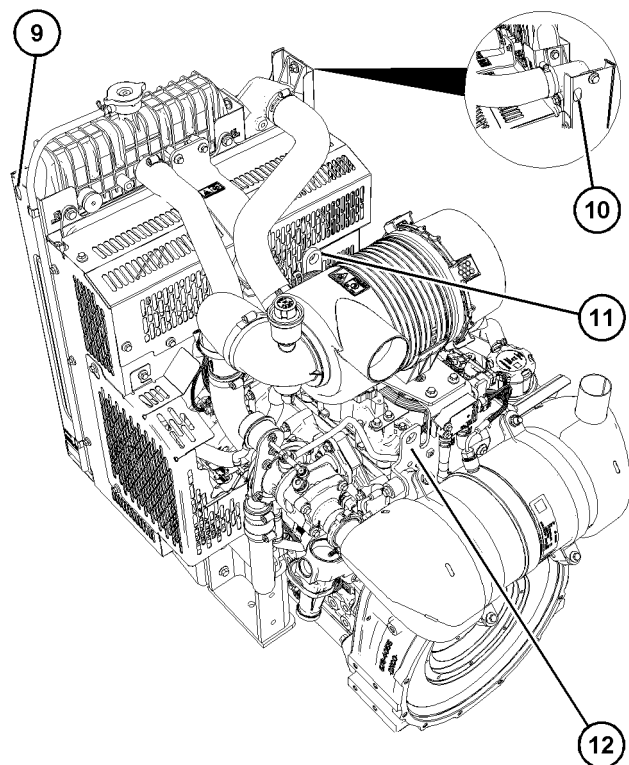

Illustration 60

g07629987

Typical example of lifting eyes for the ElectropaK

- (9) Radiator lifting eye (1 of 2)
- (10) Radiator lifting eye (2 of 2)
- (11) Front lifting eye
- (12) Rear lifting eye

Remove the engine air cleaner on the ElectropaK before attaching any lifting equipment.

i07818075

Product Storage (Engine and Aftertreatment)

Perkins are not responsible for damage which may occur when an engine is in storage after a period in service.

Your Perkins dealer or your Perkins distributor can assist in preparing the engine for extended storage periods.

Condition for Storage

The engine must be stored in a water proof building. The building must be kept at a constant temperature. Engines that are filled with Perkins ELC will have coolant protection to an ambient temperature of -36°C (-32.8°F). The engine must not be subjected to extreme variations in temperature and humidity.

Storage Period

An engine can be stored for up to 6 months provided all the recommendation are adhered to.

Storage Procedure

Keep a record of the procedure that has been completed on the engine.

Note: Do not store an engine that has biodiesel in the fuel system.

1. Ensure that the engine is clean and dry.
 - a. If the engine has been operated using biodiesel, the system must be drained and new filters installed. The fuel tank will require flushing.
 - b. Fill the fuel system with an ultra low sulfur fuel. For more information on acceptable fuels refer to this Operation and Maintenance Manual, "Fluid recommendations". Operate the engine for 15 minutes to remove all biodiesel from the system.
2. Drain any water from the primary filter water separator. Ensure that the fuel tank is full.
3. The engine oil will not need to be drained to store the engine. Provided the correct specification of engine oil is used the engine can be stored for up to 6 months. For the correct specification of engine oil refer to this Operation and Maintenance Manual, "Fluid recommendations".
4. Remove the drive belts from the engine.

Sealed Coolant System

Ensure that the cooling system is filled with Perkins ELC, or an antifreeze that meets "ASTM D6210" specification.

Open Cooling System

Ensure that all cooling drain plugs have been opened. Allow the coolant to drain. Install the drain plugs. Place a vapor phase inhibitor into the system. The coolant system must be sealed once the vapor phase inhibitor has been introduced. The effect of the vapor phase inhibitor will be lost if the cooling system is open to the atmosphere.

For maintenance procedures refer to this Operation and Maintenance Manual.

Aftertreatment

No special procedures are required. The exhaust outlet of the aftertreatment should be capped. Before storing, the engine and the aftertreatment must be enclosed in a cover that will provide protection from the environment. Store the engine and aftertreatment together, the aftertreatment is matched to the engine and not interchangeable. If the aftertreatment is disconnected from the engine, the inlet and outlet must be capped on the aftertreatment and engine.

Monthly Checks

The crankshaft must be rotated to change the spring loading on the valve train. Rotate the crankshaft more than 180 degrees. Visibly check for damage or corrosion to the engine and aftertreatment.

Ensure that the engine and aftertreatment are covered completely before storage. Log the procedure in the record for the engine.

Removal from Storage

1. Install the drive belt, refer to this Operation and Maintenance Manual, "Alternator and Fan Belts - Inspect/Adjust" for the tension of the belt.
2. Ensure that the engine oil level is correct. Ensure that the coolant level is correct. Ensure that the fuel system is full and the fuel system is primed. Refer to the Operation and Maintenance Manual, "Fuel system - Prime" for more information.
3. Turn the power ON and check the operation of the warning lamps. Start engine, refer to Operation and Maintenance Manual, "Starting the Engine" for more information.

Features and Controls

i09669737

Alarms and Shutoffs

Shutoffs

i09635148

The shutoffs are electrically operated or mechanically operated. The electrically operated shutoffs are controlled by the Electronic Control Module (ECM).

Shutoffs are set at critical levels for the following items:

- Coolant operating temperature
- Oil operating pressure

The particular shutoff may need to be reset before the engine will start.

NOTICE

Always determine the cause of the engine shutdown. Make necessary repairs before attempting to restart the engine.

Be familiar with the following items:

- Types and locations of shutoff
- Conditions which cause each shutoff to function
- The resetting procedure that is required to restart the engine

Alarms

NOTICE

When an alarm is activated, corrective measures must be taken before the situation becomes an emergency in order to avoid possible engine damage.

The alarms are electrically operated. The operations of the alarms are controlled by the ECM.

The alarm is operated by a sensor or by a switch. When the sensor or the switch is activated, a signal is sent to the ECM. An event code is created by the ECM. The ECM will send a signal to illuminate the lamp.

Your engine may be equipped with the following sensors or switches:

Fuel rail pressure – The fuel rail pressure sensor measures the high pressure or low pressure in the fuel rail. The ECM will Check the pressure.

Engine oil pressure – The engine oil pressure switch indicates when oil pressure drops below rated system pressure, at a set engine speed.

Coolant temperature – The coolant temperature sensor indicates high jacket water coolant temperature.

Gauges and Indicators

Your engine may not have the same gauges or all the gauges that are described. For more information about the gauge package, see the OEM information.

Gauges provide indications of engine performance. Ensure that the gauges are in good working order. Determine the normal operating range by observing the gauges over a period of time.

Noticeable changes in gauge readings indicate potential gauge or engine problems. Problems may also be indicated by gauge readings that change even if the readings are within specifications. Determine and correct the cause of any significant change in the readings. Consult your Perkins dealer or your Perkins distributor for assistance.

NOTICE

If no oil pressure is indicated, STOP the engine. If maximum coolant temperature is exceeded, STOP the engine. Engine damage can result.



Engine Oil Pressure – The oil pressure should be greatest after a cold engine is started. The typical engine oil pressure with SAE10W30 is 207 kPa to 413 kPa (30 psi to 60 psi) at rated rpm.

A lower oil pressure is normal at low idle. If the load is stable and the gauge reading changes, perform the following procedure:

1. Remove the load.
2. Reduce engine speed to low idle.
3. Check and maintain the oil level.



Jacket Water Coolant Temperature – Typical temperature range is 82° to 96° C (147.6° to 172.8°F). The maximum allowable temperature with the pressurized cooling system at 90 kPa (13 psi) is 112° C (233.6° F). Higher temperatures may occur under certain conditions. The water temperature reading may vary according to load. The reading should never exceed the boiling point for the pressurized system that is being used.

If the engine is operating above the normal range and steam becomes apparent, perform the following procedure:

1. Reduce the load and the engine rpm.
2. Inspect the cooling system for leaks.
3. Determine if the engine must be shut down immediately or if the engine can be cooled by reducing the load.



Tachometer – This gauge indicates engine speed (rpm). When the throttle control lever is moved to the full throttle position without load, the engine is running at high idle. The engine is running at the full load rpm when the throttle control lever is at the full throttle position with maximum rated load.

NOTICE

To help prevent engine damage, never exceed the high idle rpm. Overspeeding can result in serious damage to the engine. The engine can be operated at high idle without damage, but should never be allowed to exceed high idle rpm.



Ammeter – This gauge indicates the amount of charge or discharge in the battery charging circuit. Operation of the indicator should be to the right side of “0” (zero).



Engine - Electrical Preheat – This indicator comes “ON” to show that the glow plug preheat is active. The engine should only be set to “RUN” after indicator lamp on the display turns “OFF” .



Fuel Level – This gauge indicates the fuel level in the fuel tank. The fuel level gauge operates when the “START/STOP” switch is in the “ON” position.



Service Hour Meter – The gauge indicates operating time of the engine.

Monitoring System

WARNING

If the Shutdown mode has been selected and the warning indicator activates, engine shutdown may take as little as 20 seconds from the time the warning indicator is activated. Depending on the application, special precautions should be taken to avoid personal injury. The engine can be re-started following shutdown for emergency maneuvers, if necessary.

NOTICE

The Engine Monitoring System is not a guarantee against catastrophic failures. Programmed delays and derate schedules are designed to minimize false alarms and provide time for the operator to stop the engine.

The following parameters are monitored:

- Engine speed/timing
- Temperature and pressures sensors
- Atmospheric pressure (Barometric pressure)
- Battery voltage
- Differential pressure in the diesel particulate filter
- The amount of soot in the diesel particulate filter

Programmable Options and Systems Operation

WARNING

If the Warning/Derate/Shutdown mode has been selected and the warning indicator activates, bring the engine to a stop whenever possible. Depending on the application, special precautions should be taken to avoid personal injury.

The engine can be programmed to the following modes:

“Warning”

The orange “Warning” lamp will turn “ON” and the warning signal is activated continuously to alert the operator that one or more of the engine parameters is not within normal operating range.

“Derate”

The orange “Warning” lamp will be “Flashing” . After the warning, the engine power will be derated. The warning lamp will begin to flash when the derating occurs.

The engine will be derated if the engine exceeds preset operational limits. The engine derate is achieved by restricting the amount of fuel that is available for each injection. The fuel reduction depends on the severity of the fault that has caused the engine derate, typically up to a limit of 50%. This reduction in fuel results in a predetermined reduction in engine power.

“Shutdown”

The orange warning will be “Flashing” . After the warning, the engine power will be derated. The engine will continue at the rpm of the set derate until a shutdown of the engine occurs. After shutdown the red stop lamp will illuminate.

A shutdown of the engine after being triggered is immediate. The engine can be restarted after a shutdown for use in an emergency. However, the cause of the initial shutdown may still exist.

If there is a signal for high coolant temperature, there will be a 2 second delay to verify the condition.

If there is a signal for low oil pressure, there will be a 2 second delay to verify the condition.

For more information or assistance for repairs, consult your Perkins distributor.

i07426635

Monitoring System (Engine Warning Indicators)

Table 3

Table for Warning Indicators					
Warning Indicator	Shutdown Indicator	Indicator State	Description of the Indication	Engine Status	Operator Action
ON	ON	Indicator Check	Keyswitch in the ON position all Indicators should illuminate for 0.5 of a second.	Power ON, Indicator check Engine is not operating.	If any of the Indicators will not illuminate during the Indicator check, the fault must be investigated immediately. If any Indicator stays illuminated or flash, the fault must be investigated immediately.
OFF	OFF	No Fault	-	Engine operating normally.	None
Level 1					
ON (Solid)	OFF	Level 1	An active diagnostic code is present.	The engine is operating, but one or more diagnostic codes are present.	As soon as possible the diagnostic code should be investigated.
Level 2					
Flashing	OFF	Level 2	The ECM has detected an abnormal condition.	If enabled, the engine will be derated.	Stop the engine. Investigate the fault.
Level 3					
Flashing	ON	Level 3	Engine condition is abnormal.	The engine will automatically shutdown. If shutdown is not enabled, the engine can operate but may cause damage .	Stop engine immediately. Investigate the fault.

i07397434

i07399976

Overspeed

The overspeed threshold is the Revolution Per Minute (RPM) listed below for the engines covered by this Operation and Maintenance Manual (OMM).

- 403J-E17T _____ 3700 RPM
- 404J-E22T _____ 3700 RPM
- 404J-E22TA _____ 3700 RPM

Sensors and Electrical Components

The illustration within the section shows the typical locations of the sensors and other electrical components on the Industrial engine. Specific engines may appear different due to the application.

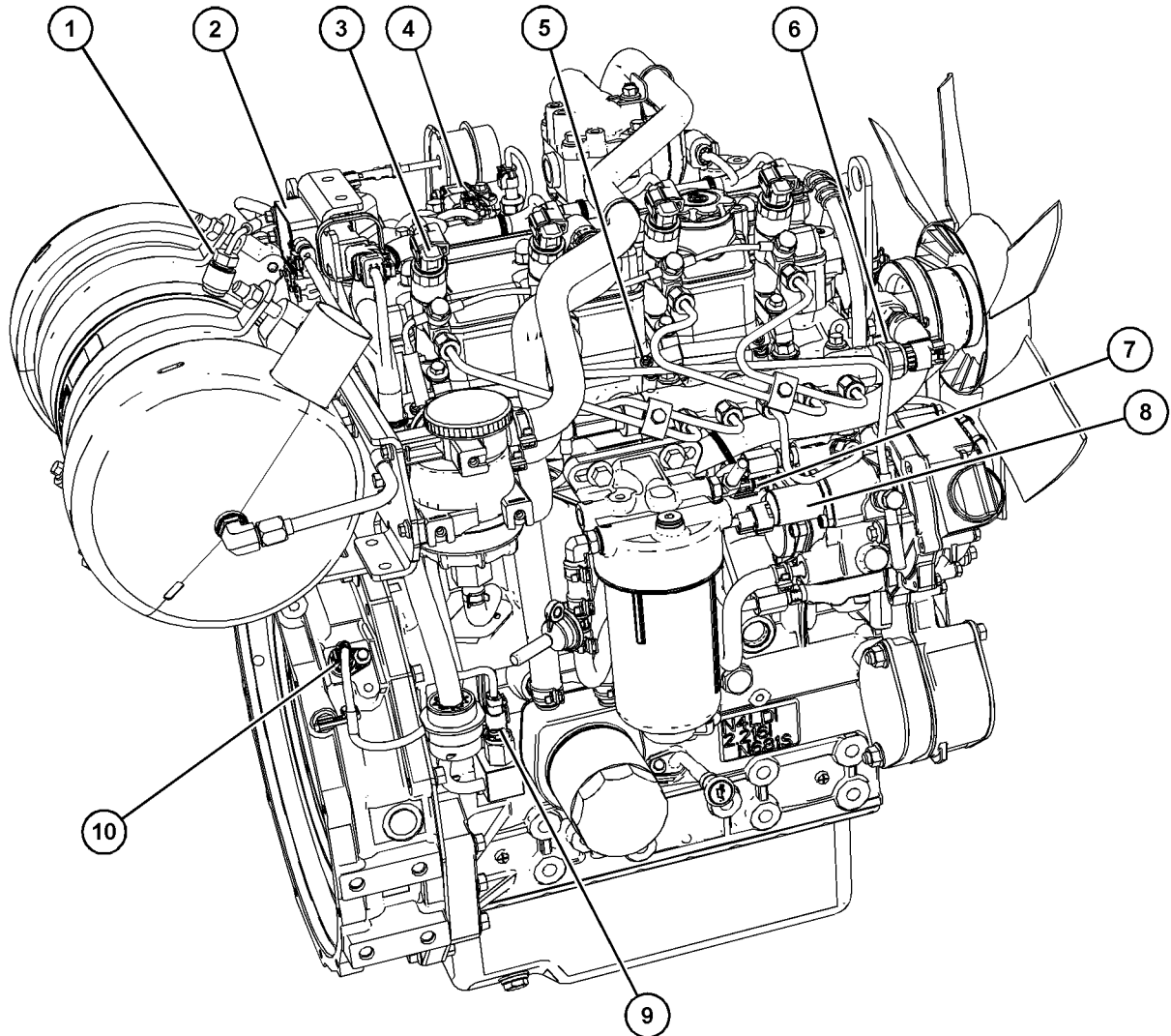

Illustration 61

g06310720

Typical example

- | | | |
|--|--|---|
| (1) Diesel Particulate Filter (DPF) inlet temperature sensor | (5) Glow plug | (8) Suction control valve for the fuel injection pump |
| (2) Differential pressure sensor | (6) Fuel pressure sensor (fuel rail pressure sensor) | (9) Oil pressure switch |
| (3) Electronic unit injector | (7) Fuel temperature Sensor | (10) Crankshaft speed/timing sensor |
| (4) Inlet manifold air temperature sensor | | |

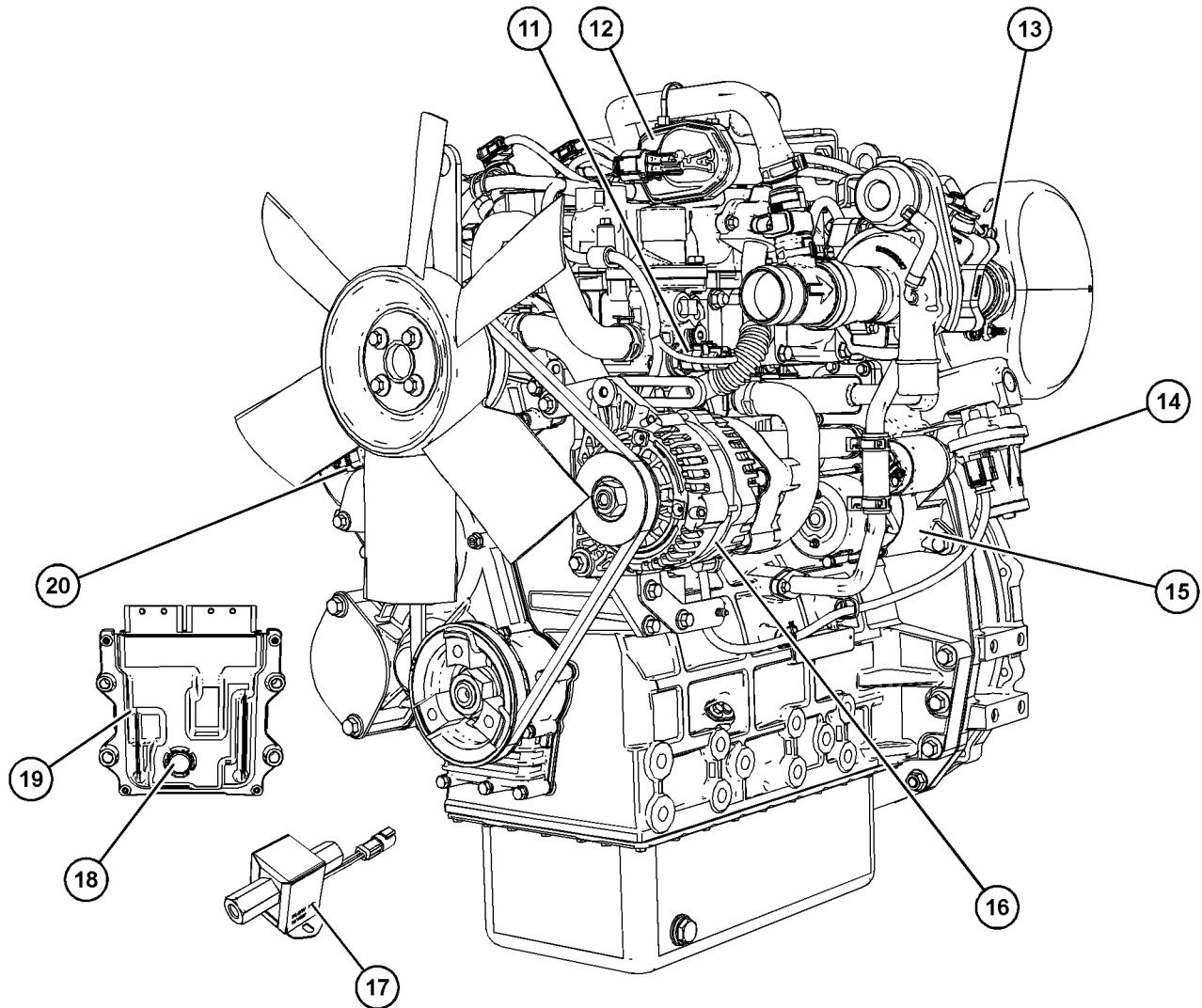

Illustration 62

g06310761

Typical example

- | | | |
|---|---|---|
| (11) Coolant temperature sensor | (14) NOx Reduction System (NRS) control valve | (17) Fuel priming pump |
| (12) Throttle valve | (15) Starting motor | (18) Vent for atmospheric pressure sensor |
| (13) Diesel Oxidation Catalyst (DOC) inlet temperature sensor | (16) Alternator | (19) Electronic Control Module (ECM) |
| | | (20) Camshaft speed/timing sensor |

Engine Diagnostics

i05142509

Fault Logging

The system provides the capability of Fault Logging. When the Electronic Control Module (ECM) generates an active diagnostic code, the code will be logged in the memory of the ECM. The codes that have been logged by the ECM can be identified by the electronic service tool. The active codes that have been logged will be cleared when the fault has been rectified or the fault is no longer active.

i06748909

Engine Operation with Active Diagnostic Codes

If a diagnostic lamp illuminates during normal engine operation, the system has identified a situation that is not within the specification. Use electronic service tools to check the active diagnostic codes.

Note: The power may be limited until the problem is corrected. If the oil pressure is within the normal range, the engine may be operated at the rated speed and load. However, maintenance should be performed as soon as possible.

The active diagnostic code should be investigated. The cause of the problem should be corrected as soon as possible. If the cause of the active diagnostic code is repaired and there is only one active diagnostic code, the diagnostic lamp will turn off.

Operation of the engine and performance of the engine can be limited as a result of the active diagnostic code that is generated. Acceleration rates may be significantly slower. Refer to the Troubleshooting for more information on the relationship between these active diagnostic codes and engine performance.

i04053849

Engine Operation with Intermittent Diagnostic Codes

If a diagnostic lamp illuminates during normal engine operation and the diagnostic lamp shuts off, an intermittent fault may have occurred. If a fault has occurred, the fault will be logged into the memory of the Electronic Control Module (ECM).

In most cases, stopping the engine will not be necessary because of an intermittent code. However, the operator should retrieve the logged fault codes and the operator should reference the appropriate information in order to identify the nature of the event. The operator should log any observation that could have caused the lamp to light.

- Low power
- Limits of the engine speed
- Engine vibration or engine noise

This information can be useful to help troubleshoot the situation. The information can also be used for future reference. For more information on diagnostic codes, refer to the Troubleshooting Guide for this engine.

i05142533

Configuration Parameters

System configuration parameters affect the emissions of the engine or the power of the engine. System configuration parameters are programmed at the factory. Normally, system configuration parameters would never change through the life of the engine. System configuration parameters must be reprogrammed if an Electronic Control Module (ECM) is replaced. System configuration parameters are not reprogrammed if the ECM software is changed.

For more information, refer to Troubleshooting, "System Configuration Parameters".

Engine Starting

i07907357

i04053911

Before Starting Engine

Perform the required daily maintenance and other periodic maintenance before the engine is started. Inspect the engine compartment. This inspection can help prevent major repairs at a later date. Refer to the Operation and Maintenance Manual, "Maintenance Interval Schedule" for more information.

- Ensure that the engine has an adequate fuel supply.
- Open the fuel supply valve (if equipped).

If the engine has not been started for several weeks, fuel may have drained from the fuel system. Air may have entered the filter housing. Also, when fuel filters have been changed, some air pockets will be trapped in the engine. In these instances, prime the fuel system. Refer to the Operation and Maintenance Manual, "Fuel System - Prime" for more information on priming the fuel system. Also, check that the fuel specification is correct and that the fuel condition is correct. Refer to the Operation and Maintenance Manual, "Fuel Recommendations".

WARNING

Engine exhaust contains products of combustion which may be harmful to your health. Always start and operate the engine in a well ventilated area and, if in an enclosed area, vent the exhaust to the outside.

- Do not start the engine or move any of the controls if there is a "DO NOT OPERATE" warning tag or similar warning tag attached to the start switch or to the controls.
- Reset all of the shutoffs or alarm components.
- Ensure that any driven equipment has been disengaged. Minimize electrical loads or remove any electrical loads.

Cold Weather Starting

WARNING

Do not use aerosol types of starting aids such as ether. Such use could result in an explosion and personal injury.

The ability to start the engine will be improved at temperatures below -18°C (0°F) or at high altitude above 2000 m (6561 ft) from the use of a jacket water heater or extra battery capacity.

When Group 2 diesel fuel is used, the following items provide a means of minimizing starting problems and fuel problems in cold weather: Engine oil pan heaters, jacket water heaters, fuel heaters, and fuel line insulation.

Use the procedure that follows for cold weather starting.

Note: Do not adjust the engine speed control during start-up. The electronic control module (ECM) will control the engine speed during start-up.

In cold conditions the ECM on turbocharged engines is programmed with an idle hold feature that will prevent the engine from being revved above 800 Revolutions Per Minute (RPM) until the engine reaches the required operating temperature.

1. Disengage any driven equipment.

Note: During key ON, the indicator lamps will be illuminated for 0.5 of a second to check the lamp operation. If any of the indicator lamps do not illuminate, check the bulb. If any indicator lamps stay illuminated or flash, refer to Troubleshooting, "Indicator Lamp Circuit - Test".

2. Turn the keyswitch to the RUN position. Leave the keyswitch in the RUN position until the wait to start lamp for the glow plugs is extinguished.
3. When the wait to start lamp for the glow plugs is extinguished, turn the keyswitch to the START position to engage the electric starting motor and crank the engine.

Note: The operating period of the warning light for the glow plugs will change due to the ambient air temperature.

NOTICE

Do not engage the starting motor when flywheel is turning. Do not start the engine under load.

If the engine fails to start within 30 seconds, release the starter switch or button and wait two minutes to allow the starting motor to cool before attempting to start the engine again.

4. Allow the keyswitch to return to the RUN position after the engine starts.

5. Repeat step 2 through step 4 if the engine fails to start.

Note: The engine should not be “raced” to speed up the warm-up process.

6. Allow the engine to idle for 3 to 5 minutes, or allow the engine to idle until the water temperature indicator begins to rise. When idling after the engine has started in cold weather, increase the engine rpm from 1000 to 1200 rpm. This operation will warm up the engine more quickly. Maintaining an elevated low idle speed for extended periods will be easier with the installation of a hand throttle.

7. Operate the engine at low load until all systems reach operating temperature. Check the gauges during the warm-up period.

8. Constant speed engines could be allowed to reach operating speed with no load. Operate the engine for 2 minutes before applying load.

i07907097

Starting the Engine

 **WARNING**

Do not use aerosol types of starting aids such as ether. Such use could result in an explosion and personal injury.

Note: Do not adjust the engine speed control during start-up. The electronic control module (ECM) will control the engine speed during start-up.

Starting the Engine

1. Disengage any equipment that is driven by the engine.

Note: During key ON, the indicator lamps will be illuminated for 0.5 of a second to check the lamp operation. If any of the indicator lamps do not illuminate check the bulb. If any indicator lamps stay illuminated or flash, refer to Troubleshooting, “Indicator Lamp Circuit - Test”.

2. Turn the keyswitch to the RUN position. Leave the keyswitch in the RUN position until the warning light for the glow plugs is extinguished.

3. When the wait to start lamp for the glow plugs has been extinguished turn the keyswitch to the START position. The starter motor will then crank the engine.

Note: The operating period of the wait to start lamp for the glow plugs will change due to the ambient air temperature.

NOTICE

Do not engage the starting motor when flywheel is turning. Do not start the engine under load.

If the engine fails to start within 30 seconds, release the starter switch or button and wait two minutes to allow the starting motor to cool before attempting to start the engine again.

4. Allow the keyswitch to return to the RUN position after the engine starts.

5. Repeat step 2 through step 4 if the engine fails to start.

6. Constant speed engines should be allowed to reach operating speed with no load. Operate engine for 2 minutes before applying load.

i07907104

Starting with Jump Start Cables

(Do Not Use This Procedure in Hazardous Locations that have Explosive Atmospheres)

WARNING

The connection of battery cables to a battery and the disconnection of battery cables from a battery may cause an explosion which may result in injury or death. The connection and the disconnection of other electrical equipment may also cause an explosion which may result in injury or death. The procedures for the connection and the disconnection of battery cables and other electrical equipment should only be performed in a nonexplosive atmosphere.

WARNING

Improper jump start cable connections can cause an explosion resulting in personal injury.

Prevent sparks near the batteries. Sparks could cause vapors to explode. Do not allow jump start cable ends to contact each other or the engine.

Note: If possible, first diagnose the reason for the starting failure. Refer to Troubleshooting, “Engine Will Not Crank and Engine Cranks But Will Not Start” for further information. Make any necessary repairs. If the engine will not start only due to the condition of the battery, either charge the battery, or start the engine by using another battery with jump-start cables. The condition of the battery can be rechecked after the engine has been switched OFF.

NOTICE

Ensure that a 12 VDC battery source is used to start the engine. Never attempt to start an engine from an external power source such as electric welding equipment, which has a voltage that is unsuitable for engine starting and will damage the electrical system.

NOTICE

Using a battery source with the same voltage as the electric starting motor. Use ONLY equal voltage for jump starting. The use of higher voltage will damage the electrical system.

Do not reverse the battery cables. The alternator can be damaged. Attach ground cable last and remove first.

Turn all electrical accessories OFF before attaching the jump start cables.

Ensure that the main power switch is in the OFF position before attaching the jump start cables to the engine being started.

1. Turn the start switch on the stalled engine to the OFF position. Turn off all the engines accessories.
 2. Connect one positive end of the jump-start cable to the positive cable terminal of the discharged battery. Connect the other positive end of the jump-start cable to the positive cable terminal of the electrical source.
 3. Connect one negative end of the jump-start cable to the negative cable terminal of the electrical source. Connect the other negative end of the jump-start cable to the engine block or to the chassis ground. This procedure helps to prevent potential sparks from igniting the combustible gases that are produced by some batteries.
- Note:** The engine ECM must be powered before the starting motor is operated or damage can occur.
4. Start the engine in the normal operating procedure. Refer to this Operation and Maintenance Manual, “Starting the Engine”.
 5. Immediately after the engine is started, disconnect the jump-start cables in reverse order.

After jump starting, the alternator may not be able to recharge fully batteries that are severely discharged. The batteries must be replaced or charged to the proper voltage with a battery charger after the engine is stopped. Many batteries which are considered unusable are still rechargeable. Refer to Operation and Maintenance Manual, “Battery - Replace” and Testing and Adjusting Manual, “Battery - Test”.

i07818134

After Starting Engine

After starting, the engine may be held at low speed for up to 30 seconds to allow engine systems to stabilize. The duration will depend on ambient temperature, time since last run and other factors.

After starting the engine and allowing the engine to stabilize, increase the engine speed to 1500 RPM for 10 seconds to ensure that the alternator begins to charge the battery.

Note: In ambient temperatures from 0° to 48°C (0° to 86.4°F), the warm-up time is approximately 3 minutes. In temperatures below 0°C (32°F), additional warm-up time may be required.

When the engine idles during warm-up, observe the following conditions:

Do not check the high-pressure fuel lines with the engine or the starting motor in operation. If you inspect the engine in operation, always use the proper inspection procedure to avoid a fluid penetration hazard. Refer to Operation and Maintenance Manual, "General Hazard Information" for more information.

- Check for fluid and air leaks at idle rpm, and at one-half full rpm (no load on the engine) before operating the engine under load. This check may not be possible in some applications.
- Allow the engine to idle for 3 to 5 minutes, or allow the engine to idle until the water temperature indicator begins to rise. Check all gauges during the warm-up period.

Constant speed engines should be allowed to operate at low idle for 3 minutes before used at operational speed. If the low idle option is not available, then operate the engine at operational speed with no load for 2 minutes.

Note: Gauge readings should be observed and the data should be recorded frequently whilst the engine is operating. Comparing the data over time will help to determine normal readings for each gauge. Comparing data over time will also help detect abnormal operating developments. Significant changes in the readings should be investigated.

Engine Operation

i09996632

Engine Operation

Correct operation and maintenance are key factors in obtaining the maximum life and economy of the engine. If the directions in the Operation and Maintenance Manual are followed, costs can be minimized and engine service life can be maximized.

The time that is needed for the engine to reach normal operating temperature is only a few minutes.

The engine can be operated at the rated rpm after the engine is started and after the engine reaches operating temperature. The engine will reach normal operating temperature sooner during a low engine speed (rpm) and during a low-power demand. This procedure is more effective than idling the engine at no load. The engine should reach operating temperature in a few minutes.

Avoid excess idling or excess low load operation. Excessive idling or excessive low load operation can cause:

- Carbon build-up
- Increased oil consumption - Higher than expected oil consumption
- Engine slobber ('wetstacking') - Exhaust manifold "slobber" (black oily substance found leaking from exhaust manifold joints)
- Loss of performance
- Harmful deposits in the aftertreatment system (if equipped) - Emissions Aftertreatment systems may lose efficiency or malfunction

These issues are harmful to the engine.

Perkins recommends a minimum load factor of 30% over any 8-hour period of engine operation. Within this period, load should be maintained at >30% for at least 20 continuous minutes, which may help in avoiding any engine operation issues. Perkins also recommends limiting periods of low idle running to avoid engine operation issues.

Gauge readings should be observed and the data should be recorded frequently while the engine is operating. Comparing the data over time will help to determine normal readings for each gauge. Comparing data over time will also help detect abnormal operating developments. Significant changes in the readings should be investigated.

Engine Operation and the Aftertreatment System

The exhaust gases and hydrocarbon particles from the engine first pass through Diesel Oxidation Catalyst (DOC). Some of the gasses and matter are oxidized as the gasses pass through the DOC. The gasses then pass through the Diesel Particulate Filter (DPF). The DPF collects the soot and any ash that is produced by the combustion in the engine. During regeneration, the soot is converted into a gas and the ash remains in the DPF.

The DPF may require the exhaust gas temperature to rise to remove the soot. If necessary, the throttle valve is operated to help in rising the exhaust temperature.

This design of DPF will not require a service maintenance interval. The DPF can be expected to function properly for the useful life of the engine (emissions durability period), as defined by regulation, subject to prescribed maintenance requirements being followed.

A fault code will be active for any DPF system-related issue. Follow the troubleshooting guide to rectify the issue.

If the DPF loses function, or is tampered with in any way, the check engine lamp, and an amber action (if equipped) will illuminate. A fault code will also annunciate. The lamps and fault code will remain active until the problem is rectified.

NOTICE

The engine and emissions control system shall be operated, used, and maintained in accordance with the instructions provided. Failure to follow the instructions could result in emissions performance that does not meet the requirements applicable to the category of the engine. No deliberate tampering with, or misuse of the engine emissions control system should take place. Prompt action is critical to rectify any incorrect operation, use, or maintenance of the emissions control system.

Carbon Dioxide (CO₂) Emissions Statement

Emissions regulations require that the value of the CO₂ emissions be reported to the end user.

For the 403J-E17T engine, **905.42 g/kWh** was determined to be the CO₂ value during the EU type approval process.

For the 404J-E22T engine, **905.42 g/kWh** was determined to be the CO₂ value during the EU type approval process.

For the 404J-E22TA engine, **799.13 g/kWh** was determined to be the CO₂ value during the EU type approval process.

i07818141

For the 404J-E22TA ElectropaK engine, **687.52 g/kWh** was determined to be the CO₂ value during the EU type approval process.

These values were recorded in EU type approval certificate. This CO₂ measurement results from testing over a fixed test cycle, under laboratory conditions, with a(n) (parent) engine representative of the engine type (engine family). This value shall not imply, or express any guarantee of the performance of a particular engine.

i01646335

Engaging the Driven Equipment

1. Operate the engine at one-half of the rated rpm, when possible.
2. Engage the driven equipment without a load on the equipment, when possible.

Interrupted starts put excessive stress on the drive train. Interrupted starts also waste fuel. To get the driven equipment in motion, engage the clutch smoothly with no load on the equipment. This method should produce a start that is smooth and easy. The engine rpm should not increase and the clutch should not slip.

3. Ensure that the ranges of the gauges are normal when the engine is operating at one-half of the rated rpm. Ensure that all gauges operate properly.
4. Increase the engine rpm to the rated rpm. Always increase the engine rpm to the rated rpm before the load is applied.
5. Apply the load. Begin operating the engine at low load. Check the gauges and equipment for proper operation. After normal oil pressure is reached and the temperature gauge begins to move, the engine may be operated at full load. Check the gauges and equipment frequently when the engine is operated under load.

Extended operation at low idle or at reduced load may cause increased oil consumption and carbon buildup in the cylinders. This carbon buildup results in a loss of power and/or poor performance.

Fuel Conservation Practices

The efficiency of the engine can affect the fuel economy. The design and technology in manufacturing provides maximum fuel efficiency in all applications. Always ensure that genuine filters are used. Follow the recommended procedures to attain optimum performance for the life of the engine.

- Avoid spilling fuel.

Fuel expands when the fuel is warmed up. The fuel may overflow from the fuel tank. Inspect fuel lines for leaks. Repair the fuel lines, as needed.

- Be aware of the properties of the different fuels. Use only the recommended fuels. Refer to the Operations and Maintenance Manual, "Fuel Recommendations" for further information.
- Avoid unnecessary idling.
- Shut off the engine rather than idle for long periods of time.
- Observe the service indicator frequently. Keep the air cleaner elements clean.
- Ensure that the turbocharger is operating correctly so that the proper air/fuel ratio is maintained. Clean exhaust indicates proper functioning.
- Maintain a good electrical system.

One faulty battery cell will overwork the alternator and can consume excess power and excess fuel.

- Ensure that the belts are correctly adjusted. The belts should be in good condition. Refer to the Specifications manual for further information.
- Ensure that all the connections of the hoses are tight. The connections should not leak.
- Ensure that the driven equipment is in good working order.
- Cold engines consume excess fuel. Utilize heat from the jacket water system and the exhaust system, when possible. Keep cooling system components clean and keep cooling system components in good repair. Never operate the engine without water temperature regulators. All these items will help maintain operating temperatures.

Cold Weather Operation

i08769716

Cold Weather Operation

Perkins Diesel Engines can operate effectively in cold weather. During cold weather, the starting and the operation of the diesel engine depends the following items:

- The type of fuel that is used
- The viscosity of the engine oil
- The operation of the glow plugs
- Optional Cold starting aid
- Battery condition
- Ambient air temperature and altitude
- Parasitic load of the application
- Application hydraulic and transmission oil viscosities

This section will cover the following information:

- Potential problems that are caused by cold-weather operation
- Recommended steps which can be taken to minimize starting problems and operating problems when the ambient air temperature is between 0° to -40 °C (32° to 40 °F).

The operation and maintenance of an engine in freezing temperatures is complex . This complexity is because of the following conditions:

- Weather conditions
- Engine applications

Recommendations from your Perkins dealer or your Perkins distributor are based on past proven practices. The information that is contained in this section provides guidelines for cold-weather operation.

Hints for Cold-Weather Operation

- After starting the engine, the engine speed will be governed for up to a maximum of 30 seconds. After this period, the engine should be operated at low loads until a minimum coolant operating temperature of 80° C (176° F) is achieved.

- Achieving operating temperature will help prevent the intake valves and exhaust valves from sticking.
- The cooling system and the lubrication system for the engine do not lose heat immediately upon shutdown. This heat retention means that an engine can be shut down for a period and the retained heat within the engine will allow the engine readily start.
- Install the correct specification of engine lubricant before the beginning of cold weather. Refer to this Operation and Maintenance Manual, "Fluid Recommendations" for the recommended viscosity of oil.
- Check all rubber parts (hoses, fan drive belts) weekly.
- Check all electrical wiring and connections for any fraying or damaged insulation.
- Keep all batteries fully charged and warm by ensuring that the engine is allowed correct operation at normal operating temperature.
- Fill the fuel tank at the end of each shift.
- Check the air cleaners and the air intake daily. Check the air intake more often when you operate in snow.
- Ensure that the glow plugs are in working order. Refer to Troubleshooting, "Glow Plug Starting Aid-Test".

WARNING

Personal injury or property damage can result from alcohol or starting fluids.

Alcohol or starting fluids are highly flammable and toxic and if improperly stored could result in injury or property damage.

WARNING

Do not use aerosol types of starting aids such as ether. Such use could result in an explosion and personal injury.

- For jump starting with cables in cold weather, refer to the Operation and Maintenance Manual, "Starting with Jump-Start Cables." for instructions.

Viscosity of the Engine Lubrication Oil

Correct engine oil viscosity is essential. Oil viscosity affects lubrication properties and the wear protection that the oil provides for the engine. Refer to this Operation and Maintenance Manual, "Fluid Recommendations" for the recommended viscosity of oil.

At temperatures below -10°C (14°F) damage to engine components can occur if the engine is allowed to operate at high load and speed immediately after starting.

Recommendations for the Coolant

Provide cooling system protection for the lowest expected outside temperature. Refer to this Operation and Maintenance Manual, "Fluid Recommendations" for the recommended coolant mixture.

In cold weather, check the coolant often for the correct glycol concentration to ensure adequate freeze protection.

Engine Block Heaters

Engine block heaters (if equipped) heat the engine jacket water that surrounds the combustion chambers. This heat provides the following functions:

- Starting ability is improved.
- Warm up time is reduced.

An electric block heater can be activated once the engine is stopped. A block heater can be 110 V DC or 240 V DC. The output can be 600/1000W. Consult your Perkins dealer or your Perkins distributor for more information.

Idling the Engine

After starting the engine, the engine speed will be governed for a maximum period of 30 seconds. When idling after the engine is started in cold weather, increase the engine rpm from 1000 rpm to 1200 rpm. This idling will warm up the engine more quickly. Maintaining an elevated low idle speed for extended periods will be easier with the installation of a hand throttle. The engine should not be "raced" to speed up the warm up process.

Whilst the engine is idling, the application of a light load (parasitic load) will help in achieving the minimum operating temperature. The minimum coolant operating temperature is 80°C (176°F).

Recommendations for Coolant Warm Up

Warm up an engine that has cooled below normal operating temperatures due to inactivity. The warm up procedure should be performed before the engine is returned to full operation. During operation in very cold temperature conditions, damage to engine valve mechanisms can result from engine operation for short intervals. This damage can happen if the engine is started and the engine is stopped many times without being operated to warm up completely.

When the engine is operated below normal operating temperatures, fuel and oil are not burned completely in the combustion chamber. This fuel and oil causes soft carbon deposits to form on the valve stems. Generally, the deposits do not cause problems and the deposits are burned off during operation at normal engine operating temperatures.

When starting and stopping an engine many times without being operated to warm up completely, the carbon deposits become thicker. This starting and stopping can cause the following problems:

- Free operation of the valves is prevented.
- Valves become stuck.
- Pushrods may become bent.
- Other damage to valve train components can result.

For these reasons, when the engine is started, the engine must be operated until the coolant temperature is 80°C (176°F) minimum. Carbon deposits on the valve stem will be kept at a minimum. The free operation of the valves and the valve components will be maintained.

The engine must be warmed thoroughly to keep other engine parts in better condition. The service life of the engine will generally be extended. Lubrication will be improved. There will be less acid and less sludge in the oil. This condition will provide longer service life for the engine bearings, the piston rings, and other parts. However, limit unnecessary idle time to 10 minutes to reduce wear and unnecessary fuel consumption.

The Water Temperature Regulator and Insulated Heater Lines

The engine is equipped with a water temperature regulator. When the engine coolant is below the correct operating temperature, jacket water circulates through the engine cylinder block and into the engine cylinder head. The coolant then returns to the cylinder block via an internal passage that bypasses the valve of the coolant temperature regulator. This return ensures that coolant flows around the engine under cold operating conditions. The water temperature regulator begins to open when the engine jacket water has reached the correct minimum operating temperature. As the jacket water coolant temperature rises above the minimum operating temperature, the water temperature regulator opens further allowing more coolant through the radiator to dissipate excess heat.

The progressive opening of the water temperature regulator operates the progressive closing of the bypass passage between the cylinder block and head. This action ensures maximum coolant flow to the radiator to achieve maximum heat dissipation.

Note: Do not restrict the air flow. Restriction of the air flow can damage the fuel system. Perkins discourages the use of all air flow restriction devices such as radiator shutters. Restriction of the air flow can result in the following: high exhaust temperatures, power loss, excessive fan usage, and reduction in fuel economy.

A cab heater is beneficial in cold weather. The feed from the engine and the return lines from the cab should be insulated to reduce heat loss to the outside air.

Recommendation for Crankcase Breather Protection

Crankcase ventilation gases contain a large quantity of water vapor. This water vapor can freeze in cold ambient conditions and can plug or damage the crankcase ventilation system. If the engine is operated in temperatures of -25°C (-13°F) or lower, measures must be taken to prevent freezing and plugging of the breather system. There are two breather variants, closed crankcase breather where the breather gases are filtered and directed back into the air inlet system upstream compressor. A second variant is open crank case breather, where the filtered gases are vented to ambient at sump level. Insulated hoses and an insulated canister assembly should be installed for both breather variants. For the closed crank case breather, a heater unit must also be installed into the breather system. Both measures are required to protect the engine when working in temperatures of -25°C (-13°F) or lower.

i07818744

Fuel and the Effect from Cold Weather

Note: Only use grades of fuel that are recommended by Perkins. Refer to this Operation and Maintenance Manual, "Fluid Recommendations".

Properties of the diesel fuel can have a significant effect on the engine cold start capability. It is critical that the low temperature properties of diesel fuel are acceptable for the minimum ambient temperature the engine is expected to see in operation.

Following properties are used to define fuels low temperature capability:

- Cloud point
- Pour point
- Cold Filter Plugging Point (CFPP)

The cloud point of the fuel is the temperature at which waxes naturally found in the diesel fuel begin to form crystals. The cloud point of the fuel must be below lowest ambient temperature to prevent filters from plugging.

Pour point is the last temperature before the fuel flow stops and waxing of the fuel will start.

Cold Filter Plugging Point (CFPP) is a temperature at which a particular fuel will pass through a standardized filtration device. This CFPP gives an estimate of the lower operability temperature of fuel

Be aware of these properties when diesel fuel is purchased. Consider the average ambient air temperature for the engines application. Engines that are fueled in one climate may not operate well if the engines are shipped to colder climate. Problems can result due to changes in temperature.

Before troubleshooting for low power or for poor performance in the winter, check the fuel for waxing

The following components can provide a means of minimizing fuel waxing problems in cold weather:

- Fuel heaters, which may be an OEM option
- Fuel line insulation, which may be an OEM option

Winter and arctic grades of diesel fuel are available in the countries and territories with severe winters. For more information refer to the Operation and Maintenance Manual, "Fuel For Cold-Weather Operation"

Another important fuel property which can affect cold start and operation of diesel engine is Cetane number. Detail and requirements of this property are given in this Operation and Maintenance Manual, "Fluid Recommendations".

i05359588

Fuel Related Components in Cold Weather

Fuel Tanks

Condensation can form in partially filled fuel tanks. Top off the fuel tanks after you operate the engine.

Fuel tanks should contain some provision for draining water and sediment from the bottom of the tanks.

Some fuel tanks use supply pipes that allow water and sediment to settle below the end of the fuel supply pipe.

Some fuel tanks use supply lines that take fuel directly from the bottom of the tank. If the engine is equipped with this system, regular maintenance of the fuel system filter is important.

Drain the water and sediment from any fuel storage tank at the following intervals: weekly, service intervals and refueling of the fuel tank. Draining will help prevent water and/or sediment from being pumped from the fuel storage tank and into the engine fuel tank.

Fuel Filters

After you change the fuel filter, always prime the fuel system in order to remove air bubbles from the fuel system. Refer to the Operation and Maintenance Manual in the Maintenance Section for more information on priming the fuel system.

The micron rating and the location of a primary fuel filter is important in cold-weather operation. The In-line filter, primary fuel filter, and the fuel supply line are the most common components that are affected by cold fuel.

Fuel Heaters

Note: The OEM may equip the application with fuel heaters. If so, the temperature of the fuel must not exceed 73 °C (163 °F) at the fuel transfer pump. The fuel heater should be installed before the electric lift pump.

For more information about fuel heaters (if equipped), refer to the OEM information.

Engine Stopping

i03756631

i06832774

Stopping the Engine

NOTICE

Stopping the engine immediately after it has been working under load, can result in overheating and accelerated wear of the engine components.

Avoid accelerating the engine prior to shutting it down.

Avoiding hot engine shutdowns will maximize turbo-charger shaft and bearing life.

Note: Individual applications will have different control systems. Ensure that the shutoff procedures are understood. Use the following general guidelines to stop the engine.

1. Remove the load from the engine. Reduce the engine speed (rpm) to low idle. Allow the engine to idle for 5 minutes to cool the engine.
 2. Stop the engine after the cool down period according to the shutoff system on the engine. Turn the ignition key switch to the OFF position. If necessary, refer to the instructions that are provided by the OEM.
-

NOTICE

Before any service or repairs are performed, ensure that the power supply to the engine is disconnected.

i07764840

Emergency Stopping

NOTICE

Emergency shutoff controls are for EMERGENCY use ONLY. DO NOT use emergency shutoff devices or controls for normal stopping procedure.

The Original Equipment Manufacturer (OEM) may have equipped the application with an emergency stop button. For more information about the emergency stop button, refer to the OEM information.

Ensure that any components for the external system that support the engine operation are secured after the engine is stopped.

After Stopping Engine

Note: Before you check the engine oil, do not operate the engine for at least 10 minutes in order to allow the engine oil to return to the oil pan.

- Check the crankcase oil level. Maintain the oil level between the “MIN” mark and the “MAX” mark on the engine oil level gauge.
 - If necessary, perform minor adjustments. Repair any leaks and tighten any loose bolts.
 - If the engine is equipped with a service hour meter, note the reading. Perform the maintenance that is in the Operation and Maintenance Manual, “Maintenance Interval Schedule”.
 - Fill the fuel tank in order to help prevent accumulation of moisture in the fuel. Do not overfill the fuel tank.
-

NOTICE

Only use antifreeze/coolant mixtures recommended in the Refill Capacities and Recommendations topic that is in this Operation and Maintenance Manual. Failure to do so can cause engine damage.

- Allow the engine to cool. Check the coolant level.
- If freezing temperatures are expected, check the coolant for correct antifreeze protection. The cooling system must be protected against freezing to the lowest expected outside temperature. Add the correct coolant/water mixture, if necessary.
- Perform all required periodic maintenance on all driven equipment. This maintenance is outlined in the instructions from the OEM.

Maintenance Section

Refill Capacities

i10018133

Refill Capacities

Lubrication System

Engines Equipped with a Standard Oil Pan

The refill capacities for the engine crankcase reflect the approximate capacity of the crankcase or sump plus standard oil filters. Auxiliary oil filter systems will require more oil. Refer to the OEM specifications for the capacity of the auxiliary oil filter. Refer to the Operation and Maintenance Manual, "Maintenance Section" for more information on Lubricant Specifications.

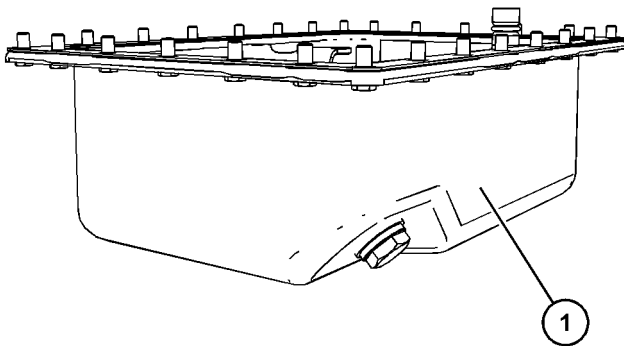

Illustration 63 g06544043

Typical example

(1) Standard Oil Pan

Table 4

403J-E17T Engine Refill Capacities		
Compartment or System	Minimum	Maximum
Crankcase Oil Sump ⁽¹⁾	4.8 L (1.27 US gal)	6.3 L (1.66 US gal)
Total Lubrication System ⁽²⁾		

(continued)

(Table 4, contd)

- (1) More than one style of sump may be used on these engines. Use these values to estimate the refill capacity. Use the engine oil level gauge to fill the engine to the correct oil level. Record the result in this table. These values are the approximate capacities for the Crankcase Oil Sump which includes the standard factory installed oil filters. Engines with auxiliary oil filters will require more oil. Refer to the OEM specifications for the capacity of the auxiliary oil filter.
- (2) The Total Lubrication System includes the capacity for the Crankcase Oil Sump plus the capacity of factory installed oil filters and other filters added to the lubrication system. Enter the value for the capacity of the Total Lubrication System in this row.

Table 5

404J-E22T and 404J-E22TA Engines Refill Capacities		
Compartment or System	Minimum	Maximum
Crankcase Oil Sump ⁽¹⁾	7.2 L (1.90 US gal)	8.5 L (2.25 US gal)
Total Lubrication System ⁽²⁾		

- (1) More than one style of sump may be used on these engines. Use these values to estimate the refill capacity. Use the engine oil level gauge to fill the engine to the correct oil level. Record the result in this table. These values are the approximate capacities for the Crankcase Oil Sump which includes the standard factory installed oil filters. Engines with auxiliary oil filters will require more oil. Refer to the OEM specifications for the capacity of the auxiliary oil filter.
- (2) The Total Lubrication System includes the capacity for the Crankcase Oil Sump plus the capacity of factory installed oil filters and other filters added to the lubrication system. Enter the value for the capacity of the Total Lubrication System in this row.

Engines Equipped with a Balancer Oil Pan

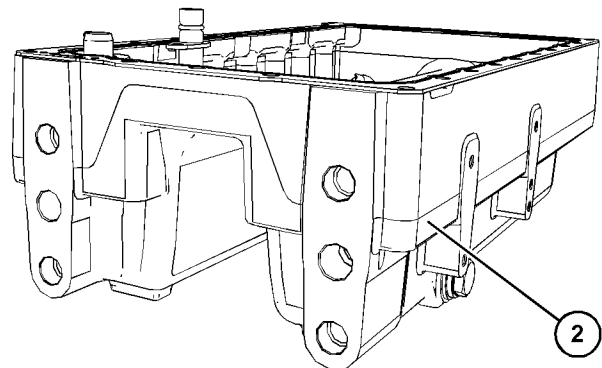

Illustration 64 g06544060

Typical example of Industrial Engine With a Balancer Oil Pan

(2) Oil Pan with a balancer

Table 6

404J-E22T and 404J-E22TA Engines With a Balancer Oil Pan Refill Capacities		
Compartment or System	Minimum	Maximum
Crankcase Oil Sump ⁽¹⁾	4.97 L (1.313 US gal)	6.14 L (1.622 US gal)
Total Lubrication System ⁽²⁾		

- (1) More than one style of sump may be used on these engines. Use these values to estimate the refill capacity. Use the engine oil level gauge to fill the engine to the correct oil level. Record the result in this table. These values are the approximate capacities for the Crankcase Oil Sump which includes the standard factory installed oil filters. Engines with auxiliary oil filters will require more oil. Refer to the OEM specifications for the capacity of the auxiliary oil filter.
- (2) The Total Lubrication System includes the capacity for the Crankcase Oil Sump plus the capacity of factory installed oil filters and other filters added to the lubrication system. Enter the value for the capacity of the Total Lubrication System in this row.

Cooling System

Industrial Engine

To maintain the cooling system, the Total Cooling System capacity must be known. The approximate capacity is for the engine cooling system. External System capacities will vary among applications. Refer to the OEM specifications for the External System capacity. This capacity information will be needed to determine the amount of coolant that is required for the Total Cooling System.

Table 7

403J-E17T Engine Refill Capacities		
Compartment or System	Liters	US gallons
Engine Only	3.7	0.98
Total Cooling System ⁽¹⁾		

- (1) The Total Cooling System capacity with factory installed radiator.

Table 8

404J-E22T Refill Capacities		
Compartment or System	Liters	US gallons
Engine Only	4.5	1.19
Total Cooling System ⁽¹⁾		

- (1) The Total Cooling System capacity with factory installed radiator.

Table 9

404J-E22TA Refill Capacities		
Compartment or System	Liters	US gallons
Engine Only	4.5	1.19
Total Cooling System ⁽¹⁾		

- (1) The Total Cooling System capacity with factory installed radiator.

Industrial Open Power Unit (IOPU)

Table 10

403J-E17T IOPU Refill Capacities		
Compartment or System	Liters	US gallons
Engine Only	3.7	0.98
Radiator	4.2	1.11
Total Cooling System	7.9	2.09

Table 11

404J-E22T IOPU Refill Capacities		
Compartment or System	Liters	US gallons
Engine Only	4.5	1.19
Radiator	4.2	1.11
Total Cooling System	8.7	2.30

Table 12

404J-E22TA IOPU Refill Capacities		
Compartment or System	Liters	US gallons
Engine Only	4.5	1.19
Radiator	3.7	0.98
Total Cooling System	8.2	2.17

ElectropaK

Table 13

404J-E22TA ElectropaK Refill Capacities		
Compartment or System	Liters	US gallons
Engine Only	4.5	1.19

(Table 13, contd)

Radiator	3.7	0.98
Total Cooling System	8.2	2.17

i07818799

Fluid Recommendations (General Fuel Information)

• Glossary

- ISO _____International Standards Organization
- ASTM _____American Society for Testing and Materials
- BTL _____Biomass to liquid
- CFPP _____Cold Filter Plugging Point
- CFR _____Co-ordinating Fuel Research
- CTL _____Coal to liquid
- DPF _____Diesel Particulate Filter
- EPA _____Environmental Protection Agency of the United States
- FAME _____Fatty Acid Methyl Esters
- GTL _____Gas to liquid
- HFRR _____High Frequency Reciprocating Rig for Lubricity testing of diesel fuels
- HVO_____Hydrotreated Vegetable Oil
- PPM _____Parts Per Million
- RME _____Rape Methyl Ester
- SME _____Soy Methyl Ester
- ULSD _____Ultra Low Sulfur Diesel
- v/v _____(volume of solute)/(volume of solution)

General Information

NOTICE

Every attempt is made to provide accurate, up-to-date information. By use of this document you agree that Perkins Engines Company Limited is not responsible for errors or omissions.

NOTICE

These recommendations are subject to change without notice. Contact your local Perkins distributor for the most up-to-date recommendations.

Diesel Fuel Requirements

Perkins is not in a position to continuously evaluate and monitor all worldwide distillate diesel fuel specifications that are published by governments and technological societies.

The "Perkins Specification for Distillate Diesel Fuel" provides a known reliable baseline to judge the expected performance of distillate diesel fuels that are derived from conventional sources.

Satisfactory engine performance depends on the use of a good quality fuel. The use of a good quality fuel will give the following results: long engine life and acceptable exhaust emissions levels. The fuel must meet the minimum requirements that are stated in the table 14 .

NOTICE

The footnotes are key part of the Perkins "Specification for Distillate Diesel Fuel" Table. Read ALL of the footnotes.

Table 14

"Perkins Specification for Distillate Diesel Fuel"				
Property	UNITS	Requirements	"ASTM" Test	"ISO/Other" Test
Aromatics	%Volume	35% maximum	"D1319"	"ISO 3837"
Ash	%Weight	0.01% maximum	"D482"	"ISO 6245"
Carbon Residue on 10% Bottoms	%Weight	0.20% maximum	"D524"	"ISO 4262"
Cetane Number ⁽¹⁾	-	40 minimum in North America 45 minimum in European Union	"D613 or D6890"	"ISO 5165"
Cloud Point	°C	The cloud point must not exceed the lowest expected ambient temperature.	"D2500"	"ISO 3015"
Copper Strip Corrosion	-	No. 3 maximum	"D130"	"ISO 2160"
Distillation	°C	50% at 250° C (482° F) minimum 90% at 350° C (662° F) maximum	"D86"	"ISO 3405"
Density at 15 °C (59 °F) ⁽²⁾	kg/M ³	800 minimum and 860 maximum	No equivalent test	"ISO 3675""ISO 12185"
Flash Point	°C	legal limit	"D93"	"ISO 2719"
Thermal Stability	-	Minimum of 80% reflectance after aging for 180 minutes at 150 °C (302 °F)	"D6468"	No equivalent test
Pour Point	°C	6 °C (42.8 °F) minimum below ambient temperature	"D97"	"ISO 3016"
Sulfur ⁽³⁾	%mass	0.0015 % maximum	"D5453"	"ISO 20846"
Kinematic Viscosity ⁽⁴⁾	MM ² /S (cSt)	The viscosity of the fuel that is delivered to the fuel injection pump. 1.4 minimum and 4.5 maximum	"D445"	"ISO 3405"
Water and sediment	% weight	0.05% maximum	"D1796"	"ISO 3734"
Water	% weight	0.02% maximum	"D1744"	No equivalent test
Sediment	% weight	0.05% maximum	"D473"	"ISO 3735"
Gums and Resins ⁽⁵⁾	mg/100mL	10 mg per 100 mL maximum	"D381"	"ISO 6246"
Lubricity corrected wear scar diameter at 60 °C (140 °F). ⁽⁶⁾	mm	0.52 maximum	"D6079"	"ISO 12156-1"
Fuel Cleanliness ⁽⁷⁾	-	"ISO 18/16/13"	"D7619"	"ISO 4406"
Trace Metals ⁽⁸⁾	mg/mg	Max 1 or non-detectable	"D7111"	
Oxidation Stability	g/m ³	Max 25	"D2274"	"ISO 12205"
	Hours ⁽⁹⁾	Min 20		"EN 15751"

⁽¹⁾ A fuel with a higher cetane number than 45 is recommended to operate at a higher altitude in cold weather

⁽²⁾ Density range allowed includes summer and winter diesel fuel grades.

(continued)

Maintenance Section
General Fuel Information

(Table 14, contd)

- (3) Ultra Low Sulfur Diesel Fuel with sulphur content less than 0.0015 percent 15 PPM (mg/kg) must be used. Use of diesel fuel with higher than 15 PPM sulphur limit in these engines will harm or permanently damage emissions control systems. Also, use of diesel fuel with higher than 15 PPM sulphur limit can shorten service interval.
- (4) The values of the fuel viscosity are the values as the fuel is delivered to the fuel injection pumps. Fuel should also meet the minimum viscosity requirement and the fuel should meet the maximum viscosity requirements at 40 °C (104 °F) of either the "ASTM D445" test method or the "ISO 3104" test method. If a fuel with a low viscosity is used, cooling of the fuel may be required to maintain "1.4 cSt" or greater viscosity at the fuel injection pump. Fuels with a high viscosity might require fuel heaters to lower the viscosity to "1.4 cSt" at the fuel injection pump.
- (5) Follow the test conditions and procedures for gasoline (motor).
- (6) The lubricity of a fuel is a concern with low sulfur and ultra low sulfur fuel. Fuel with higher wear scar diameter than 0.52 mm (0.0205 inch) will lead to reduced service life and premature failure of the fuel system. Refer to the lubricity section of this "Operation and Maintenance Manual" Fluid Recommendations for more information.
- (7) Recommended cleanliness level for fuel as dispensed into machine or engine fuel tank is "ISO 18/16/13" or cleaner as per "ISO 4406". Refer to the "Contamination Control Recommendations for Fuels".
- (8) Examples of trace metals include but not limited to Cu, Fe, Mn, Na, P, Pb, Si, and Zn. Use of metal-based additives is not allowed.
- (9) Additional limit for fuel containing FAME. Fuel containing more than 2% v/v FAME must meet both tests.

Note: The owner and the operator of the engine has the responsibility of using the fuel that is prescribed by the EPA and other appropriate regulatory agencies.

NOTICE

Operating with fuels that do not meet the Perkins recommendations can cause the following effects: Starting difficulty, reduced fuel filter service life, poor combustion, deposits in the fuel injectors, significantly reduce service life of the fuel system. Also, the creation of deposits in the combustion chamber and reduced service life of the engine.

NOTICE

The Perkins 400J series of diesel engine must be operated using Ultra Low Sulfur Diesel. The sulphur content of this fuel must be lower than 15 PPM. This fuel complies with the emissions regulations that are prescribed by the Environmental Protection Agency of the United States.

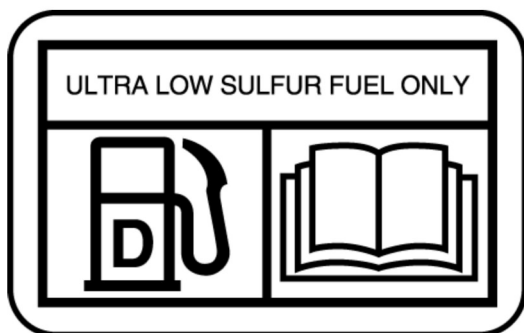

Illustration 65

g02157153

Illustration 65 is a representation of the label that will be installed next to the fuel filler cap on the fuel tank of the application.

The fuel specifications that are listed in the table 15 are released as acceptable to use on all 400J series of engine.

Table 15

Acceptable Fuel Specification for the 403J-E17, and 404J-E22 Series of Engines ⁽¹⁾	
Fuel Specification	Comments
EN590	European Automotive Diesel Fuel (DERV)
"ASTM D975 GRADE 1D S15"	"North American Light Distillate Diesel fuel with less than 15 PPM sulfur level"
"ASTM D975 GRADE 2D S15"	"North American Middle Distillate general-purpose Diesel fuel with less than 15 PPM sulfur level"
"JIS K2204"	"Japanese Diesel Fuel" Must meet the requirements that are stated in the lubricity section of this "Operation and Maintenance Manual" Fluid Recommendations.
"BS 2869: 2010 CLASS A2 or EU equivalent"	UK Off-Road Diesel fuel
"CEN TS15940"	"Paraffinic diesel fuel from synthesis or hydrotreatment", "Biomass-to-liquid" (BTL), "Gas-to-liquid" (GTL), called Hydrotreated Vegetable Oil (HVO). Refer to the Renewable and Alternative Fuels section of this "Operation and Maintenance Manual" Fluid Recommendations for more information.
B20 Biodiesel Blend	Refer to the Recommendation for Biodiesel and Using B20 section of this "Operation and Maintenance Manual" Fluid Recommendations for more information.

⁽¹⁾ All the fuels must comply with the specification in the table for the Perkins Specification Distillate Diesel Fuel.

Diesel Fuel Characteristics

Cetane Number

Cetane number is a measure of the ignition quality of diesel fuel. Fuel that has a higher cetane number will give a shorter ignition delay and will produce a better ignition quality. Cetane numbers are derived for fuels against proportions of cetane and heptamethylnonane in the standard CFR engine. Refer to "ISO 5165" for the test method.

In Europe for non-road Stage V emissions regulations require minimum cetane number of 45. In the North America, minimum cetane number requirement is 40.

Cetane number affect engine cold start ability, exhaust emissions, combustion noise, and altitude performance. Fuel with a higher cetane number is desirable and recommended. This is particularly important for operations in cold weather and at high altitude.

Viscosity

Viscosity is the property of a liquid of offering resistance to shear or flow. Viscosity decreases with increasing temperature. This decrease in viscosity follows a logarithmic relationship for normal fossil fuel. The common reference is to kinematic viscosity. Kinematic viscosity is the quotient of the dynamic viscosity that is divided by the density. The determination of kinematic viscosity is normally by readings from gravity flow viscometers at standard temperatures. Refer to "ISO 3104" for the test method.

The viscosity of the fuel is significant because fuel serves as a lubricant for the fuel system components. Fuel must have sufficient viscosity to lubricate the fuel system in both extremely cold temperatures and extremely hot temperatures. If the kinematic viscosity of the fuel is lower than "1.4 cSt" at the fuel injection pump, damage to the fuel injection pump can occur. This damage can be excessive scuffing and seizure. Low viscosity may lead to difficult hot restarting, stalling, and loss of performance. High viscosity may result in seizure of the pump.

Perkins recommends kinematic viscosities of between 1.4 and 4.5 mm²/sec (cSt) that is delivered to the fuel injection pump. If a fuel with a low viscosity is used, cooling of the fuel may be required to maintain 1.4 mm²/sec (cSt) or greater viscosity at the fuel injection pump. Fuels with a high viscosity might require fuel heaters to lower the viscosity to 4.5 cSt at the fuel injection pump.

Density

Density is the mass of the fuel per unit volume at a specific temperature. This parameter has a direct influence on engine performance and a direct influence on emissions. This influence determines from a heat output given injected volume of fuel. This parameter is quoted in kg/m³ at 15 °C (59 °F).

Perkins recommends a density of 841 kg/m³ to obtain the correct power output. Lighter fuels are acceptable but these fuels will not produce the rated power.

Sulfur

The level of sulfur is governed by emissions legislations. Regional regulations, national regulations, or international regulations can require a fuel with a specific sulfur limit. The sulfur content of the fuel and the fuel quality must comply with all existing local regulations for emissions.

Perkins 403J, and 404J series diesel engines have been designed to operate only with Ultra Low Sulfur Diesel (ULSD) fuel. By using the test methods "ASTM D5453, or ISO 20846", the content of sulfur in ULSD fuel must be below 15 PPM (mg/kg) or 0.0015% mass.

In the USA, EPA regulations require the use ULSD fuel with less than 0.0015 percent (15 PPM) (mg/kg) sulfur content.

In Europe, sulfur free diesel fuels with sulphur content less than 0.0010 percent (10 PPM) (mg/kg) is required by regulation for use in engines certified to EU nonroad Stage V emissions.

NOTICE

Use of diesel fuel with higher than 15 PPM sulphur limit in these engines will harm or permanently damage emissions control systems and/or shorten service interval.

Lubricity

Lubricity is the capability of the fuel to prevent pump wear. The fluids lubricity describes the ability of the fluid to reduce the friction between surfaces that are under load. This ability reduces the damage that is caused by friction. Fuel injection systems rely on the lubricating properties of the fuel. Until fuel sulfur limits were mandated, the fuels lubricity was generally believed to be a function of fuel viscosity.

The lubricity has particular significance to the current ultra low sulfur fuel, and low aromatic fossil fuels. These fuels are made to meet stringent exhaust emissions.

The lubricity of these fuels must not exceed wear scar diameter of 0.52 mm (0.0205 inch). The fuel lubricity test must be performed on an HFRR, operated at 60 °C (140 °F). Refer to "ISO 12156-1".

NOTICE

The fuels system has been qualified with fuel having lubricity up to 0.52 mm (0.0205 inch) wear scar diameter as tested by "ISO 12156-1". Fuel with higher wear scar diameter than 0.52 mm (0.0205 inch) will lead to reduced service life and premature failure of the fuel system.

Fuel additives can enhance the lubricity of a fuel. Contact your fuel supplier for those circumstances when fuel additives are required. Your fuel supplier can make recommendations for additives to use, and for the proper level of treatment.

Distillation

Distillation is an indication of the mixture of different hydrocarbons in the fuel. A high ratio of lightweight hydrocarbons can affect the characteristics of combustion.

Recommendation for Biodiesel and Using B20

Biodiesel is a fuel that can be defined as mono-alkyl esters of fatty acids. Biodiesel is a fuel that can be made from various feedstocks. The most commonly available biodiesel in Europe is Rape Methyl Ester (RME). This biodiesel is derived from rapeseed oil. Soy Methyl Ester (SME) is the most common biodiesel in the United States. This biodiesel is derived from soybean oil. Soybean oil or rapeseed oil are the primary feedstocks. These fuels are together known as Fatty Acid Methyl Esters (FAME).

Raw pressed vegetable oils are NOT acceptable for use as a fuel in any concentration in compression engines. Without esterification, these oils solidify in the crankcase and the fuel tank. These fuels may not be compatible with many of the elastomers that are used in engines that are manufactured today. In original forms, these oils are not suitable for use as a fuel in compression engines. Alternate base stocks for biodiesel may include animal tallow, waste cooking oils, or various other feedstocks. To use any of the products that are listed as fuel, the oil must be esterified.

Fuel made of 100 percent FAME is generally referred to as B100 biodiesel or neat biodiesel.

Biodiesel can be blended with distillate diesel fuel. The blends can be used as fuel. The most commonly available biodiesel blends are B5, which is 5 percent biodiesel and 95 percent distillate diesel fuel. B20, which is 20 percent biodiesel and 80 percent distillate diesel fuel.

Note: The percentages given are volume-based.

The U.S. distillate diesel fuel specification "ASTM D975" includes up to B5 (5 percent) biodiesel.

European distillate diesel fuel specification EN590 includes up to B7 (7 percent) biodiesel.

Note: Engines that are manufactured by Perkins are certified by use of the prescribed Environmental Protection Agency (EPA) and European Certification Agency (EPA) and European Certification Agency (EPA) and European Certification Agency (EPA) fuels. Perkins does not certify engines on any other fuel. The user of the engine has the responsibility of using the correct fuel that is recommended by the manufacturer and allowed by the EPA and other appropriate regulatory agencies.

Specification Requirements

The neat biodiesel must conform to the latest "EN14214 or ASTM D6751" (in the USA). The biodiesel can only be blended in mixture of up to 20% by volume in acceptable mineral diesel fuel meeting latest edition of "EN590 or ASTM D975 S15" designation.

In United States Biodiesel blends of B6 to B20 must meet the requirements listed in the latest edition of "ASTM D7467" (B6 to B20) and must be of an API gravity of 30-45.

In North America biodiesel and biodiesel blends must be purchased from the BQ-9000 accredited producers and BQ-9000 certified distributors.

In other areas of the world, the use of biodiesel that is BQ-9000 accredited and certified, or that is accredited and certified by a comparable biodiesel quality body to meet similar biodiesel quality standards is required.

Engine Service Requirements

Aggressive properties of biodiesel fuel may cause debris in the fuel tank and fuel lines. The aggressive properties of biodiesel will clean the fuel tank and fuel lines. This cleaning of the fuel system can prematurely block the fuel filters. Perkins recommend that after the initial usage of B20 biodiesel blended fuel the fuel filters must be replaced at 50 hours.

Glycerides present in biodiesel fuel will also cause fuel filters to become blocked more quickly. Therefore the regular service interval should be reduced to 250 hours.

When biodiesel fuel is used, crank case oil and aftertreatment systems may be influenced. This influence is due to the chemical composition and characteristics of biodiesel fuel, such as density and volatility, and to chemical contaminants that can be present in this fuel, such as alkali and alkaline metals (sodium, potassium, calcium, and magnesium).

- Crankcase oil fuel dilution can be higher when biodiesel or biodiesel blends are used. This increased level of fuel dilution when using biodiesel or biodiesel blends is related to the typically lower volatility of biodiesel. In-cylinder emissions control strategies utilized in many of the industrial latest engine designs may lead to a higher level of biodiesel concentration in the sump. The long-term effect of biodiesel concentration in crankcase oil is unknown currently.
- Perkins recommend the use of oil analysis to check the quality of the engine oil if biodiesel fuel is used. Ensure that the level of biodiesel in the fuel is noted when the oil sample is taken.

Performance Related Issues

Due to the lower energy content than the standard distillate fuel B20 will cause a power loss in order of 2 to 4 percent. In addition, over time the power may deteriorate further due to deposits in the fuel injectors.

Biodiesel and biodiesel blends are known to cause an increase in fuel system deposits, most significant of which are deposits within the fuel injector. These deposits can cause a loss in power due to restricted or modified fuel injection or cause other functional issues associated with these deposits.

Note: Perkins Fuel Cleaner (part number T400012) is most effective in cleaning and preventing the formation of deposits. Perkins Diesel Fuel Conditioner helps to limit deposit issues by improving the stability of biodiesel and biodiesel blends. For more information refer to Perkins Diesel Fuel Cleaner.

Biodiesel fuel contains metal contaminants (sodium, potassium, calcium, and/or magnesium) that form ash products upon combustion in the diesel engine. The ash can have an impact on the life and performance of aftertreatment emissions control devices and can accumulate in DPF. The ash accumulation may cause the need for more frequent ash service intervals and cause loss of performance.

General Requirements

Biodiesel has poor oxidation stability, which can result in long-term problems in the storage of biodiesel. Biodiesel fuel should be used within 6 months of manufacture. Equipment should not be stored with the B20 biodiesel blends in the fuel system.

Due to poor oxidation stability and other potential issues, it is strongly recommended that engines with limited operational time either not use B20 biodiesel blends or, whilst accepting some risk, limit biodiesel blend to a maximum of B5. Examples of applications that should limit the use of biodiesel are the following: Standby Generator sets and certain emergency vehicles.

For standby generator sets and emergency vehicles that cannot avoid use of biodiesel blends fuel quality in the engine fuel tank must be sampled and checked monthly. Test should include acid number (EN14104), oxidation stability (EN 15751 commonly known as the Rancimat test), and sediment (ISO12937). For standby generator sets oxidation stability of biodiesel blend must be 20 hours or more as per EN 15751. If the test shows that the fuel has degraded, fuel tank must be drained and engine flushed by running with the fresh high-quality diesel fuel.

Perkins strongly recommended that seasonally operated engines have the fuel systems, including fuel tanks, flushed with conventional diesel fuel before prolonged shutdown periods. An example of an application that should seasonally flush the fuel system is a combine harvester.

Microbial contamination and growth can cause corrosion in the fuel system and premature plugging of the fuel filter. Consult your supplier of fuel for assistance in selecting appropriate anti-microbial additive.

Water accelerates microbial contamination and growth. When biodiesel is compared to distillate fuels, water is naturally more likely to exist in the biodiesel. Therefore check frequently and if necessary, drain the water separator.

Materials such as brass, bronze, copper, lead, tin, and zinc accelerate the oxidation process of the biodiesel fuel. The oxidation process can cause the formation of deposits therefore these materials must not be used for fuel tanks and fuel lines.

Renewable and Alternative Fuels

Perkins supports development and use of renewable fuels through sustainability initiatives. In recent years various forms of renewable and alternative (synthetic) diesel fuels have started to emerge.

Synthetic diesel fuels are produced by gasification of various feedstock and then synthesis to liquid to obtain paraffinic diesel fuel. Based on the feedstock used these fuels are commonly referred to as Biomass To Liquid (BTL), Gas To Liquid (GTL) and Coal To Liquid (CTL). Hydrotreating of vegetable oils and animal fats is another emerging process for production of bio based diesel fuel called Hydrotreated Vegetable Oil (HVO).

BTL and HVO fuels are considered to be low carbon fuels as they reduce carbon footprint compared to fossil fuels and are commonly referred to as renewable fuels. These fuels must not be confused with biodiesel FAME which is fundamentally different fuel and is discussed in a separate section in this manual.

These paraffinic diesel fuels have virtually no sulphur or aromatics and have very high cetane numbers which enable very clean burning and efficient engine operation. Chemically these fuels are similar to diesel fuel derived from petroleum.

Paraffinic diesel fuels are considered as acceptable to use as a direct replacement to petroleum diesel or as a blendstock for petroleum diesel fuel in Perkins diesel engines provided they meet latest edition of the paraffinic diesel fuel specification "CENTS 15940". The fuel should also meet requirements described in table 14, Perkins Specification for Distillate Diesel Fuel, EN590, or latest ASTM D975 specification with the exception of density, which is inherently lower for paraffinic fuels. **Due to lower density, some rated power loss might be noticeable.**

Ensure that the fuel has got appropriate cold flow properties (cloud point and CFPP) for the minimum statistical ambient temperature the engine is expected to see in the operation. The fuel must also meet lubricity requirements as specified in the lubricity section of this "Operation and Maintenance Manual" Fluid Recommendations

Fuel for Cold-Weather Operation

The European standard "EN590" contains climate dependant requirements and a range of options. The options can be applied differently in each country. There are five classes that are given to arctic climates and severe winter climates. 0, 1, 2, 3 and 4.

Fuel that complies with "EN590" CLASS 4 can be used at temperatures as low as $-44\text{ }^{\circ}\text{C}$ ($-47.2\text{ }^{\circ}\text{F}$). Refer to "EN590" for a detailed discretion of the physical properties of the fuel.

The diesel fuel "ASTM D975 1-D" used in the United States of America may be used in very cold temperatures that are below $-18\text{ }^{\circ}\text{C}$ ($-0.4\text{ }^{\circ}\text{F}$).

Aftermarket Fuel Additives

NOTICE

Perkins does not warrant the quality or performance of non-Perkins fluids and filters.

When auxiliary devices, accessories, or consumables (filters, additives) which are made by other manufacturers are used on Perkins products, the Perkins warranty is not affected simply because of such use.

However, failures that result from the installation or use of other manufacturers devices, accessories, or consumables are NOT Perkins defects. Therefore, the defects are NOT covered under the Perkins warranty.

Supplemental diesel fuel additives are not generally recommended. This recommendation is due to potential damage to the fuel system or the engine. Your fuel supplier or the fuel manufacturer will add the appropriate supplemental diesel fuel additives.

Perkins recognizes the fact that additives may be required in some special circumstances.

Note: Some anti-corrosion additives can lead to injector fouling, this fouling can cause the injector to operate incorrectly.

Contact your fuel supplier for those circumstances when fuel additives are required. Your fuel supplier can recommend the appropriate fuel additive and the correct level of treatment.

Note: For the best results, your fuel supplier should treat the fuel when additives are required. The treated fuel must meet the requirements that are stated in table 14 .

Perkins Diesel Fuel System Cleaner

Perkins Fuel Cleaner (part number T400012) is the only fuel cleaner that is recommended by Perkins.

If biodiesel or biodiesel blends of fuel are to be used, Perkins require the use of Perkins fuel cleaner. The use of the fuel is to remove deposits within the fuel system that is created with the use of biodiesel. For more information on the use of biodiesel and biodiesel blends refer to Recommendation for Biodiesel and Using B20.

Perkins fuel cleaner will remove deposits that can form in the fuel system with the use of biodiesel and biodiesel blends. These deposits can create a loss of power and engine performance.

Once the fuel cleaner has been added to the fuel, the deposits within the fuel system are removed after 30 hours of engine operation. For maximum results, continue to use the fuel cleaner for up to 80 hours. Perkins fuel cleaner can be used on an on-going basis with no adverse impact on engine or fuel system durability.

Detailed instructions on the rate at which the fuel cleaner is to be used are on the container.

Note: Perkins fuel cleaner is compatible with existing and U.S. EPA Tier 4 nonroad certified diesel engine emission control catalysts and particulate filters. Perkins fuel system cleaner contains less than 15 ppm of sulfur and is acceptable for use with ULSD fuel.

Contamination Control Recommendations for Fuels

Fuels of "ISO 18/16/13" cleanliness level or cleaner as dispensed into the engine or application fuel tank should be used. This action will reduce risk of power loss, fuel system failures, and related down time of engines. This cleanliness level is important for new fuel system designs such as common rail injection systems and unit injectors. These fuels systems utilize higher fuel injection pressures and have tight clearances between moving parts to meet required stringent emissions regulations. Peak injection pressures in current fuel injection systems may exceed 2000 bar (29000 psi). Clearances in these systems are less than 5 µm. As a result, particle contaminants as small as 4 µm can cause scoring and scratching of internal pump and injector surfaces and of injector nozzles.

Water in the fuel causes cavitation, corrosion of fuel system parts, and provides an environment where microbial growth in the fuel can flourish. Other sources of fuel contamination are soaps, gels, or other compounds that may result from undesirable chemical interactions in the fuels, particularly in ULSD. Gels and other compounds can also form in biodiesel fuel at low temperatures or if biodiesel is stored for extended periods. The best indication of microbial contamination, fuel additives, or cold temperature gel is rapid filter plugging of bulk fuel filters or application fuel filters.

To reduce downtime due to contamination, follow these fuel maintenance guidelines.

- Use high-quality fuels per recommended and required specifications
- Fill fuel tanks with fuels of "ISO 18/16/13" cleanliness level or cleaner, in particular for engines with common rail and unit injection systems. When you refuel the tank, filter the fuel through a 4 µm absolute filter (Beta 4 = 75 up to 200) to reach the recommended cleanliness level. This filtration should be installed at the device that dispenses the fuel to the fuel tank. In addition, filtration at the dispensing point should remove water to ensure that fuel is dispensed at 500 ppm water or less.

- Perkins recommends the use of bulk fuel filter / coalescer units which clean the fuel of both particulate contamination and water in a single pass.
- Ensure that you use Perkins Advanced Efficiency Fuel Filters. Change your fuel filters per recommended service requirements or as needed.
- Drain your water separators daily.
- Drain your fuel tanks of sediment and water per the Operation and Maintenance Manual instructions.
- Install and maintain a properly designed bulk filter / coalescer filtration system. Continuous bulk filtration systems may be required to ensure that dispensed fuel meets the cleanliness target. Consult your Perkins distributor for availability of bulk filtration products.
- Centrifugal filters may need to be used as a pre-filter with fuel that is severely contaminated with gross amounts of water and/or large particulate contaminants. Centrifugal filters can effectively remove large contaminants. Centrifugal filters may not be able to remove the small abrasive particles required to achieve the recommended "ISO" cleanliness level. Bulk filter / coalescers are necessary as a final filter to achieve the recommended cleanliness level.
- Install desiccant type breathers of 4 µm or less absolute efficiency with the ability to remove water on bulk storage tanks.
- Follow proper practices of fuel transportation. Filtration from the storage tank to the application promotes the delivery of clean fuel. Fuel filtration can be installed at each transport stage to keep the fuel clean.
- Cover, protect, and ensure cleanliness of all connection hoses, fittings, and dispensing nozzles.

Consult your local Perkins distributor for additional information on Perkins designed and produced filtration products.

i07911116

Fluid Recommendations

General Coolant Information

NOTICE

Never add coolant to an overheated engine. Engine damage could result. Allow the engine to cool first.

NOTICE

If the engine is to be stored in, or shipped to an area with below freezing temperatures, the cooling system must be either protected to the lowest outside temperature or drained completely to prevent damage.

NOTICE

Frequently check the specific gravity of the coolant for proper freeze protection or for anti-boil protection.

Clean the cooling system for the following reasons:

- Contamination of the cooling system
 - Overheating of the engine
 - Foaming of the coolant
-

NOTICE

Never operate an engine without water temperature regulators in the cooling system. Water temperature regulators help to maintain the engine coolant at the proper operating temperature. Cooling system problems can develop without water temperature regulators.

Many engine failures are related to the cooling system. The following problems are related to cooling system failures: Overheating, leakage of the water pump and plugged radiators or heat exchangers.

These failures can be avoided with correct cooling system maintenance. Cooling system maintenance is as important as maintenance of the fuel system and the lubrication system. Quality of the coolant is as important as the quality of the fuel and the lubricating oil.

Coolant is normally composed of three elements: Water, additives, and glycol.

Water

NOTICE

Never use water alone as coolant. Water alone is corrosive and does not provide any protection against boiling or freezing.

Water is used in the cooling system to transfer heat.

Distilled water or deionized water is recommended for use in engine cooling systems.

DO NOT use the following types of water in cooling systems: Hard water, softened water that has been conditioned with salt and sea water.

If distilled water or deionized water is not available, use water with the properties that are listed in Table 16.

Table 16

Acceptable Water	
Property	Maximum Limit
Chloride (Cl)	40 mg/L
Sulfate (SO ₄)	100 mg/L
Total Hardness	170 mg/L
Total Solids	340 mg/L
Acidity	pH of 5.5 to 9.0

For a water analysis, consult one of the following sources:

- Local water utility company
- Agricultural agent
- Independent laboratory

Additives

Additives help to protect the metal surfaces of the cooling system. A lack of coolant additives or insufficient amounts of additives enable the following conditions to occur:

- Corrosion
- Formation of mineral deposits
- Rust
- Scale
- Foaming of the coolant

Many additives are depleted during engine operation. These additives must be replaced periodically.

Additives must be added at the correct concentration. Over concentration of additives can cause the inhibitors to drop out-of-solution. The deposits can enable the following problems to occur:

- Formation of gel compounds
- Reduction of heat transfer
- Leakage of the water pump seal
- Plugging of radiators, coolers, and small passages

Glycol

Glycol in the coolant helps to provide protection against the following conditions:

- Boiling
- Freezing
- Cavitation of the water pump

For optimum performance, Perkins recommends a 50 percent by volume of glycol in the finished coolant (also referred to as 1:1 mixture).

Note: Use a mixture that will provide protection against the lowest ambient temperature.

Note: 100 percent pure glycol will freeze at a temperature of -13°C (8.6°F).

Most conventional antifreezes use ethylene glycol. Propylene glycol may also be used. In a 1:1 mixture with distilled or deionized water, ethylene and propylene glycol provide similar protection against freezing and boiling. Refer to Table 17 and refer to table 18.

Table 17

Ethylene Glycol	
Concentration	Freeze Protection
50 Percent	-36°C (-33°F)
60 Percent	-51°C (-60°F)

NOTICE

Do not use propylene glycol in concentrations that exceed 50 percent glycol because of the reduced heat transfer capability of propylene glycol. Use ethylene glycol in conditions that require additional protection against boiling or freezing.

Table 18

Propylene Glycol	
Concentration	Freeze Protection
50 Percent	-29°C (-20°F)

Some commercially available coolants are based on alternative fluids, such as 1, 3-propanediol (beta-propylene glycol, PDO), glycerin (glycerol), or mixtures of these alternatives with ethylene/propylene glycols. At the time of publication of this document no industry standard exists for coolants based on these chemicals. Until such standard/specifications are published and evaluated, use of PDO, glycerine, or other alternative coolants are not recommended in Perkins engines.

To check the concentration of glycol in the coolant, measure the specific gravity of the coolant.

Coolant Terminology

- ELC _____ Extended Life Coolant. A coolant that relies on organic inhibitors for corrosion and cavitation protection. Also known as Organic Acid Technology (OAT) coolant.
- ELI _____ Extended Life Inhibitor
- SCA _____ Supplement Coolant Additive, concentrated inorganic inhibitor package
- ASTM _____ American Society for Testing and Materials
- Conventional Coolant _____ a coolant that relies on inorganic inhibitors for corrosion and cavitation protection
- Hybrid Coolant _____ a coolant in which the corrosion and cavitation protection is based on a mixture of organic and inorganic inhibitors.
- Extender _____ concentrated organic inhibitor package

Coolant Recommendations

The following three glycol-based coolants are recommended for use in Perkins diesel engines:

Preferred – Perkins ELC

Acceptable – A commercial heavy-duty antifreeze that meets “ASTM D6210” specifications. Must be replaced after 2 years.

Adequate – A commercial heavy-duty antifreeze that meets “ASTM D4985” specifications. Must be replaced after 1 year.

NOTICE

The Perkins industrial engines must be operated with a 1:1 (50 Percent) mixture of distilled or de-ionized water and glycol. This concentration allows the NOx reduction system to operate correctly at high ambient temperatures.

NOTICE

Do not use a commercial coolant/antifreeze that only meets the ASTM D3306 specification. This type of coolant/antifreeze is made for light automotive applications.

NOTICE

A commercial heavy-duty antifreeze that meets “ASTM D4985” specification requires a treatment with an SCA at the initial fill. Read the label or the instructions that are provided by the manufacturer of the product.

NOTICE

A commercial heavy-duty antifreeze that meets either “ASTM D4985” or “ASTM D6210” specification requires the SCA concentration to be checked at 500-hour service intervals.

Perkins recommends a 50 percent volume glycol and distilled or deionized water of the correct specification. This mixture will provide optimum performance as a coolant/antifreeze.

Distilled or deionized water is preferred. Water which has the recommended properties may be used.

Table 19

Coolant Service Life		
Coolant Type	Service Life ⁽¹⁾	Required Maintenance
Commercial Heavy-Duty Anti-freeze that meets “ASTM D6210”	3000 Service Hours or Two Years	SCA at maintenance intervals
Commercial Heavy-Duty Anti-freeze that meets “ASTM D4985”	3000 Service Hours or One Year	SCA at initial fill and SCA at maintenance intervals
Perkins ELC	6,000 Service Hours or Three Years	-

⁽¹⁾ Use the interval that occurs first. The cooling system must also be flushed out at this time. These service lives can only be met if regular coolant sampling, analysis, and proper maintenance are carried out, with the engine in normal service.

ELC

Perkins provides ELC for use in the following applications:

- Heavy-duty diesel engines
- Automotive applications

The anti-corrosion package for ELC is different from the anti-corrosion package for other coolants. ELC is an ethylene glycol base coolant. However, ELC contains organic corrosion inhibitors and antifoam agents with low amounts of nitrite. Perkins ELC has been formulated with the correct amount of these additives to provide superior corrosion protection for all metals in engine cooling systems.

ELC is available in a premixed cooling solution with distilled water. ELC is a 50 percent by volume of glycol mixture. The Premixed ELC provides freeze protection to -36°C (-33°F). The Premixed ELC is recommended for the initial fill of the cooling system. The Premixed ELC is also recommended for topping off the cooling system.

Containers of several sizes are available. Consult your Perkins distributor for the part numbers.

ELC Cooling System Maintenance

Correct additions to the Extended Life Coolant

NOTICE

Mixing Extended Life Coolant with other products reduces the Extended Life Coolant service life. Failure to follow the recommendations can reduce cooling system components life unless appropriate corrective action is performed.

To maintain the correct balance between the antifreeze and the additives, you must maintain the recommended concentration of ELC. Lowering the proportion of antifreeze lowers the proportion of additive. Lowering the ability of the coolant to protect the system will form pitting, from cavitation, from erosion, and from deposits.

NOTICE

Do not use a conventional coolant to top-off a cooling system that is filled with Extended Life Coolant (ELC).

Do not use Supplemental Coolant Additive (SCA).

Do not use ELC in systems with SCA filters. When switching from conventional coolant to ELC in a system equipped with SCA filter, remove the filter from the system to prevent ELC contamination and filter corrosion and leaks.

ELC Cooling System Cleaning

Note: If the cooling system is already using ELC, cleaning agents are not required to be used at the specified coolant change interval. Cleaning agents are only required if the system has been contaminated by the addition of some other type of coolant or by cooling system damage.

Distilled or deionized water is the only cleaning agent that is required when ELC is drained from the cooling system.

Before the cooling system is filled, the heater control (if equipped) must be set to the HOT position. Refer to the OEM to set the heater control. After the cooling system is drained and the cooling system is refilled, operate the engine until the coolant level reaches the normal operating temperature and until the coolant level stabilizes. As needed, add the coolant mixture to fill the system to the specified level.

Changing to Perkins ELC

To change from heavy-duty antifreeze to the Perkins ELC, perform the following steps:

NOTICE

Care must be taken to ensure that all fluids are contained during performance of inspection, maintenance, testing, adjusting and the repair of the product. Be prepared to collect the fluid with suitable containers before opening any compartment or disassembling any component containing fluids.

Dispose of all fluids according to local regulations and mandates.

-
1. Drain the coolant into a suitable container.
 2. Dispose of the coolant according to local regulations.
 3. Flush the system with distilled or deionized water to remove any debris.
 4. Use an appropriate cleaner to clean the system. Follow the instruction on the label.
 5. Drain the cleaner into a suitable container. Flush the cooling system with distilled or deionized water.
 6. Fill the cooling system with distilled or deionized water and operate the engine until the engine is warmed to 49° to 66°C (120° to 150°F).

NOTICE

Incorrect or incomplete flushing of the cooling system can result in damage to copper and other metal components.

To avoid damage to the cooling system, make sure that the cooling system is completely flushed with distilled or deionized water. Continue to flush the system until all signs of the cleaning agent are gone.

Most commercial cooling system cleaning agents are corrosive and their use is not recommended by Perkins. If these agents have to be used to remove heavy deposits, then they should not be left in the system any longer than recommended by the agent manufacturer and engine temperature should not exceed 30 °C. The system must be thoroughly flushed with distilled or deionized water after use of these cleaning agents.

-
7. Drain the cooling system into a suitable container and flush the cooling system with distilled or deionized water.

Note: The cooling system cleaner must be thoroughly flushed from the cooling system. Cooling system cleaner that is left in the system will contaminate the coolant. The cleaner may also corrode the cooling system.

8. Repeat Steps 6 and repeat steps 7 until the system is completely clean.
9. Fill the cooling system with the Perkins Premixed ELC.

ELC Cooling System Contamination

NOTICE

Mixing ELC with other products reduces the effectiveness of the ELC and shortens the ELC service life. Failure to follow these recommendations can result in shortened cooling system component life.

Do not mix types and specifications of coolant.

Do not mix types and specifications of SCAs.

ELC cooling systems can withstand contamination to a maximum of 10 percent of conventional heavy-duty antifreeze or SCA. If the contamination exceeds 10 percent of the total system capacity, perform ONE of the following procedures:

- Drain the cooling system into a suitable container. Dispose of the coolant according to local regulations. Flush the system with a 5 to 10 percent solution of Perkins ELC. Fill the system with the Perkins ELC.

- Maintain the system as a conventional Heavy-Duty Coolant. Treat the system with an SCA. Change the coolant at the interval that is recommended for the conventional Heavy-Duty Coolant.

Commercial Heavy-Duty Antifreeze and SCA

NOTICE

Commercial Heavy-Duty Coolant which contains Amines as part of the corrosion protection system must not be used.

NOTICE

Never operate an engine without water temperature regulators in the cooling system. Water temperature regulators help to maintain the engine coolant at the correct operating temperature. Cooling system problems can develop without water temperature regulators.

Check the antifreeze (glycol concentration) to ensure adequate protection against boiling or freezing. Perkins recommends the use of a refractometer for checking the glycol concentration. Do not use a hydrometer.

NOTICE

Do not mix types and specifications of coolant.

Do not mix types and specifications of SCAs.

Do not mix SCAs and Extenders.

Only use SCAs or Extender approved by coolant manufacturer and are compatible with coolant.

Perkins engine cooling systems should be tested at 250 hour intervals for the concentration of SCA.

Additions of SCA are based on the results of the test. SCA that is liquid may be needed at 250 hour intervals.

Adding the SCA to Heavy-Duty Coolant at the Initial Fill

Use the equation that is in Table 20 to determine the amount of SCA that is required when the cooling system is initially filled.

Coolants that conform to "ASTM D4985" and do not conform to "ASTM D6210" will require addition of SCA at initial fill.

Table 20

Equation For Adding The SCA To The Heavy-Duty Coolant At The Initial Fill
$V \times 0.07 = X$
V is the total volume of the cooling system.
X is the amount of SCA that is required.

Table 21 is an example for using the equation that is in Table 20 .

Table 21

Example Of The Equation For Adding The SCA To The Heavy-Duty Coolant At The Initial Fill		
Total Volume of the Cooling System (V)	Multiplication Factor	Amount of SCA that is Required (X)
15 L (4 US gal)	× 0.07	1.05 L (35.5 oz)

Adding SCA to the Commercial Heavy-Duty Coolant for Maintenance

Heavy-duty antifreezes of all types require periodic additions of SCA.

Test the antifreeze periodically for the concentration of SCA.

Additions of SCA are based on the results of the test. The size of the cooling system determines the amount of SCA that is needed.

Use the equation that is in Table 22 to determine the amount of SCA that is required, if necessary:

Table 22

Equation for Adding the SCA to the Commercial Heavy-Duty Coolant for Maintenance
$V \times 0.023 = X$
V is the total volume of the cooling system.
X is the amount of SCA that is required.

Table 23 is an example for using the equation that is in Table 22 .

Table 23

Example of the Equation for Adding the SCA to the Commercial Heavy-Duty Coolant for Maintenance		
Total Volume of the Cooling System (V)	Multiplication Factor	Amount of SCA that is Required (X)
15 L (4 US gal)	× 0.023	0.35 L (11.7 oz)

Cleaning the System of Heavy-Duty Antifreeze

Clean the cooling system for the following conditions.

- Clean the cooling system after used coolant is drained or before the cooling system is filled with new coolant
- Clean the cooling system whenever the coolant is contaminated or whenever the coolant is foaming
- The cooling system must be free from rust, scale, and any deposits, before corrosion inhibitors can be effective

To clean the cooling system of heavy-duty antifreeze, perform the following steps:

1. Drain the cooling system.
2. Fill the system with suitable distilled or deionized water.

NOTICE

Most commercial cooling system cleaning agents are corrosive and their use is not recommended by Perkins. If these cleaning agents have to be used to clean heavy deposits, then they should not be left in the system any longer than recommended by manufacturers. Also the engine temperature should not exceed 30° C (86° F).

The system must be thoroughly flushed with distilled or deionized water after use of cleaning agents.

NOTICE

Cleaning agents for industrial cooling system must not be used. These cleaning agents are very aggressive and cause damage to cooling system components.

3. Dissolve a suitable cleaning agent in water: use non-foaming detergent to clean oil contamination or a cooling system cleaner to clean deposits. Consult your Perkins dealer for suitable product.
4. Run the engine for approximately 30 minutes, leave the engine to cool down, and drain the system.
5. Take a sample of the solution from the system. Allow the sample to sit for at least 30 minutes and check for signs of oil or deposits. If contaminant is still present repeat step 1 to step 4.
6. Flush the system with distilled or deionized water.

7. Fill the system with new coolant.

i08193110

Fluid Recommendations

General Lubricant Information

Because of government regulations regarding the certification of exhaust emissions from the engine, the lubricant recommendations must be followed.

- API_____American Petroleum Institute
- SAE_____Society Of Automotive Engineers Inc.
- ACEA_____Association des Constructeurs European Automobiles.
- ECF_____Engine Crankcase Fluid

Licensing

The Engine Oil Licensing and Certification System by the American Petroleum Institute (API) and the Association des Constructeurs European Automobiles (ACEA) is recognized by Perkins. For detailed information about this system, see the latest edition of the "API publication No. 1509". Engine oils that bear the API symbol are authorized by API.

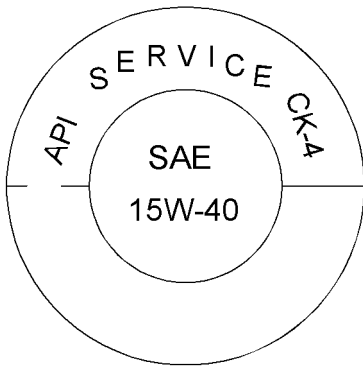

Illustration 66

g06183768

Typical API symbol

Terminology

Certain abbreviations follow the nomenclature of "SAE J754". Some classifications follow "SAE J183" abbreviations, and some classifications follow the "EMA Recommended Guideline on Diesel Engine Oil". In addition to Perkins definitions, there are other definitions that will be of assistance in purchasing lubricants. Recommended oil viscosities can be found in this publication, "Fluid Recommendations/ Engine Oil" topic (Maintenance Section).

Engine Oil

Commercial Oils

NOTICE

Perkins require the use of the following specification of engine oil. Failure to use the appropriate specification of engine oil will reduce the life of your engine.

Table 24

Classifications for the 400J Industrial Engines
Oil Specification
CK-4 ACEA E9 ECF-3

API CK-4 and ACEA E9 oil categories have the following chemical limits:

- 0.1 percent maximum sulfated ash
- 0.12 percent maximum phosphorous
- 0.4 percent maximum sulfur

The chemical limits were developed to maintain the expected life of the engine.

Maintenance intervals for engines that use biodiesel

– The oil change interval can be adversely affected by the use of biodiesel. Use oil analysis to monitor the condition of the engine oil. Use oil analysis also to determine the oil change interval that is optimum.

Note: These engine oils are not approved by Perkins and these engine oils must not be used: CC, CD, CD-2, CF-4, CG-4, CH-4, and CI-4.

Lubricant Viscosity Recommendations

The correct SAE viscosity grade of oil is determined by the minimum ambient temperature during cold engine start-up, and the maximum ambient temperature during engine operation.

Refer to illustration 67 (minimum temperature) to determine the required oil viscosity for starting a cold engine.

Refer to illustration 67 (maximum temperature) to select the oil viscosity for engine operation at the highest ambient temperature that is anticipated.

Generally, use the highest oil viscosity that is available to meet the requirement for the temperature at start-up.

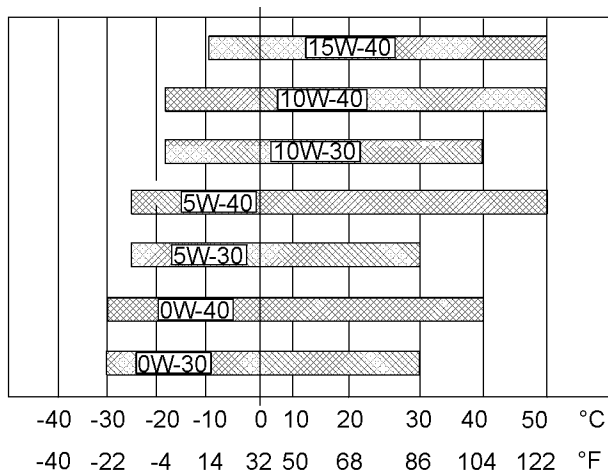

Illustration 67

g02932046

Lubricant Viscosities

Supplemental heat is recommended for cold soaked starts below the minimum ambient temperature. Supplemental heat may be required for cold soaked starts that are above the minimum temperature that is stated, depending on the parasitic load and other factors. Cold soaked starts to occur when the engine has not been operated for a period of time. This interval will allow the oil to become more viscous due to cooler ambient temperatures.

Aftermarket Oil Additives

Perkins does not recommend the use of aftermarket additives in oil. It is not necessary to use aftermarket additives to achieve the engines maximum service life or rated performance. Fully formulated, finished oils consist of base oils and of commercial additive packages. These additive packages are blended into the base oils at precise percentages to help provide finished oils with performance characteristics that meet industry standards.

There are no industry standard tests that evaluate the performance or the compatibility of aftermarket additives in finished oil. Aftermarket additives may not be compatible with the finished oils additive package, which could lower the performance of the finished oil. The aftermarket additive could fail to mix with the finished oil. This failure could produce sludge in the crankcase. Perkins discourages the use of aftermarket additives in finished oils.

To achieve the best performance from a Perkins engine, conform to the following guidelines:

- See the appropriate "Lubricant Viscosities". Refer to the illustration 67 to find the correct oil viscosity grade for your engine.
- At the specified interval, service the engine. Use new oil and install a new oil filter.
- Perform maintenance at the intervals that are specified in the Operation and Maintenance Manual, "Maintenance Interval Schedule".

Oil analysis

Some engines may be equipped with an oil sampling valve. If oil analysis is required, the oil sampling valve is used to obtain samples of the engine oil. The oil analysis will complement the preventive maintenance program.

Note: Ensure that there is sufficient quantity of oil in the engine before taking a sample of oil with the engine in operation. The engine oil capacity must not go below the minimum quantity specified on the oil level gauge. Refer to this Operation and Maintenance Manual, "Engine Oil Level - Check" for the correct procedure.

The oil analysis is a diagnostic tool that is used to determine oil performance and component wear rates. Contamination can be identified and measured by using oil analysis. The oil analysis includes the following tests:

- The Wear Rate Analysis monitors the wear of the engines metals. The amount of wear metal and type of wear metal that is in the oil is analyzed. The increase in the rate of engine wear metal in the oil is as important as the quantity of engine wear metal in the oil.
- Tests are conducted to detect contamination of the oil by water, glycol, or fuel.

- The Oil Condition Analysis determines the loss of the oils lubricating properties. An infrared analysis is used to compare the properties of new oil to the properties of the used oil sample. This analysis allows technicians to determine the amount of deterioration of the oil during use. This analysis also allows technicians to verify the performance of the oil according to the specification during the entire oil change interval.

Maintenance Recommendations

i07819420

System Pressure Release

Coolant System

WARNING

Pressurized system: Hot coolant can cause serious burn. To open cap, stop engine, wait until radiator is cool. Then loosen cap slowly to relieve the pressure.

WARNING

When the engine is in the AUTOMATIC mode, the engine can start at any moment. To avoid personal injury, always remain clear of the the engine when the engine is in the AUTOMATIC mode.

The engine can have the ability to auto start. Ensure that the power supply is isolated before any service or repair is performed.

To relieve the pressure from the coolant system, turn off the engine. Allow the cooling system pressure cap to cool. Remove the cooling system pressure cap slowly to relieve pressure.

Fuel System

To relieve the pressure from the fuel system, turn off the engine.

High-Pressure Fuel Lines

WARNING

Contact with high pressure fuel may cause fluid penetration and burn hazards. High pressure fuel spray may cause a fire hazard. Failure to follow these inspection, maintenance and service instructions may cause personal injury or death.

The high-pressure fuel lines are the fuel lines that are between the high-pressure fuel pump and the high-pressure fuel manifold and the fuel lines that are between the fuel manifold and the fuel injectors.

The high-pressure fuel lines are different from fuel lines on other fuel systems, the differences are as follows:

- The high-pressure fuel lines are constantly charged with high pressure.
- The internal pressures of the high-pressure fuel lines are higher than other types of fuel system.

Before any service or repair is performed on the engine fuel lines, perform the following tasks:

1. Stop the engine.
2. Wait for 10 minutes.

Do not loosen the high-pressure fuel lines to remove air from the fuel system.

Engine Oil

To relieve pressure from the lubricating system, turn off the engine.

i07915408

Welding on Engines with Electronic Controls

NOTICE

Because the strength of the frame may decrease, some manufacturers do not recommend welding onto a chassis frame or rail. Consult the OEM of the equipment or your Perkins dealer regarding welding on a chassis frame or rail.

Correct welding procedures are necessary to avoid damage to the engines ECM, sensors, and associated components. When possible, remove the component from the unit and then weld the component. If removal of the component is not possible, the following procedure must be followed when you weld on a unit equipped with an Electronic Engine. The following procedure is considered to be the safest procedure to weld on a component. This procedure should provide a minimum risk of damage to electronic components.

NOTICE

Do not ground the welder to electrical components such as the ECM or sensors. Improper grounding can cause damage to the drive train bearings, hydraulic components, electrical components, and other components.

Clamp the ground cable from the welder to the component that will be welded. Place the clamp as close as possible to the weld. This will help reduce the possibility of damage.

Note: Perform the welding in areas that are free from explosive hazards.

Maintenance Section
Welding on Engines with Electronic Controls

1. Stop the engine. Turn the switched power to the OFF position.
2. Ensure that the fuel supply to the engine is turned off.
3. Disconnect the negative battery cable from the battery. If a battery disconnect switch is provided, open the switch.
4. Disconnect all electronic components from the wiring harnesses. Include the following components:
 - Electronic components for the driven equipment
 - ECM
 - Sensors
 - Electric operated fuel pump
 - Electronically controlled valves
 - Relays
 - Aftertreatment ID module

NOTICE

Do not use electrical components (ECM or ECM sensors) or electronic component grounding points for grounding the welder.

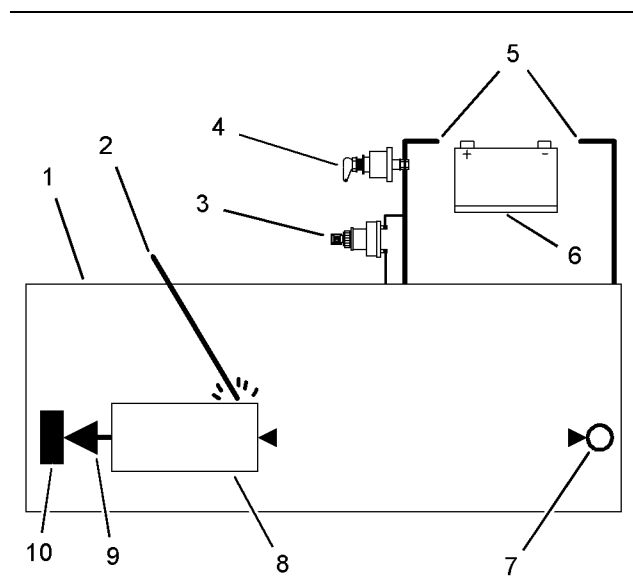

Illustration 68

g06477753

Use the example above. The current flow from the welder to the ground clamp of the welder will not damage any associated components.

- (1) Engine
- (2) Welding electrode
- (3) Keyswitch in the OFF position
- (4) Battery disconnect switch in the open position
- (5) Disconnected battery cables
- (6) Battery
- (7) Electrical/Electronic component
- (8) The component that is being welded
- (9) Current path of the welder
- (10) Ground clamp for the welder

5. Connect the welding ground cable directly to the part that will be welded. Place the ground cable as close as possible to the weld to reduce the possibility of welding current damage to the following components. Bearings, hydraulic components, electrical components, and ground straps.

Note: If electrical/electronic components are used as a ground for the welder, or electrical/electronic components are located between the welder ground and the weld, current flow from the welder could severely damage the component.

6. Protect the wiring harness from welding debris and spatter.
7. Use standard welding practices to weld the materials.

i06936264

Severe Service Application

Severe service is the application of an engine that exceeds the current published standards for that engine. Perkins maintains standards for the following engine parameters:

- Performance such as power range, speed range, and fuel consumption
- Fuel quality
- Operational Altitude
- Maintenance intervals
- Oil selection and maintenance
- Coolant type and maintenance
- Environmental qualities
- Installation
- The temperature of the fluid in the engine

Refer to the standards for the engine or consult your Perkins dealer or your Perkins distributor to determine if the engine is operating within the defined parameters.

Severe service operation can accelerate component wear. Engines that operate under severe conditions may need more frequent maintenance intervals to ensure maximum reliability and retention of full service life.

Due to individual applications, it is not possible to identify all the factors which can contribute to severe service operation. Consult your Perkins dealer or your Perkins distributor for the unique maintenance that is necessary for the engine.

The operating environment, incorrect operating procedures, and incorrect maintenance procedures can be factors which contribute to a severe service application.

Environmental Factors

Ambient temperatures – The engine may be exposed to extended operation in extremely cold environments or hot environments. Valve components can be damaged by carbon buildup if the engine is frequently started and stopped in very cold temperatures. Extremely hot intake air reduces engine performance.

Quality of the air – The engine may be exposed to extended operation in an environment that is dirty or dusty, unless the equipment is cleaned regularly. Mud, dirt, and dust can encase components.

Maintenance can be very difficult. The buildup can contain corrosive chemicals.

Buildup – Compounds, elements, corrosive chemicals, and salt can damage some components.

Altitude – Problems can arise when the engine is operated at altitudes that are higher than the intended settings for that application. Necessary adjustments should be made.

Incorrect Operating Procedures

- Extended operation at low idle
- Frequent hot shutdowns
- Frequent stop/starts exceeding 10 engine starts in 1-hour period
- Operating at excessive loads
- Operating at excessive speeds
- Operating outside the intended application

Incorrect Maintenance Procedures

- Extending the maintenance intervals
- Failure to use recommended fuel, lubricants, and coolant/antifreeze

i10049930

Maintenance Interval Schedule

When Required

“ Battery - Replace“	103
“ Battery or Battery Cable - Disconnect“	104
“ Engine - Clean“	122
“ Fuel System - Prime“	131

Daily

“ Coolant Level - Check“	115
“ Engine Air Cleaner Service Indicator - Inspect“	124
“ Engine Air Precleaner - Check/Clean“	125
“ Engine Oil Level - Check“	126
“ Fuel System Primary Filter/Water Separator - Drain“	137
“ Fuel System Primary Filter/Water Separator - Drain“	136
“ Fuel System Secondary Filter/Water Separator - Drain“	140
“ Walk-Around Inspection“	144

Every 50 Service Hours or Weekly

“ Fuel Tank Water and Sediment - Drain“	140
---	-----

Every 500 Service Hours

“ Belts - Inspect/Adjust“	104
“ Engine Air Cleaner Element - Replace“	123
“ Fan Clearance - Check“	130

Every 500 Service Hours or 1 Year

“ Battery Electrolyte Level - Check“	104
“ Engine Oil and Filter - Change“	126
“ Fuel System Primary Filter (Water Separator) Element - Replace“	133
“ Fuel System Secondary Filter - Replace“	138
“ Hoses and Clamps - Inspect/Replace“	141

“ Radiator - Clean“	142
---------------------	-----

Every 1000 Service Hours

“ Alternator and Fan Belts - Replace“	102
“ Alternator and Fan Belts - Replace“	99
“ Engine Valve Lash - Check“	130
“ Turbocharger - Inspect“	144

Every 1500 Service Hours

“ Crankcase Breather (Element) - Replace“	119
“ Crankcase Breather (Element) - Replace“	120

Every 2000 Service Hours

“ Alternator - Inspect“	99
“ Engine Mounts - Inspect“	125
“ Radiator Mounts - Inspect“	143
“ Starting Motor - Inspect“	143

Every 3000 Service Hours

“ Coolant Temperature Regulator - Replace“	118
“ Water Pump - Inspect“	145

Every 3000 Service Hours or 2 Years

“ Coolant (Commercial Heavy-Duty) - Change“	105
---	-----

Every 4000 Service Hours

“ Aftercooler Core - Inspect“	99
-------------------------------	----

Every 6000 Service Hours or 3 Years

“ Coolant (ELC) - Change“	110
---------------------------	-----

Commissioning

“ Fan Clearance - Check“	130
--------------------------	-----

i03632416

Aftercooler Core - Inspect

Note: Adjust the frequency of cleaning according to the effects of the operating environment.

Inspect the aftercooler for these items: damaged fins, corrosion, dirt, grease, insects, leaves, oil and other debris. Clean the aftercooler, if necessary.

For air-to-air aftercoolers, use the same methods that are used for cleaning radiators.

WARNING

Personal injury can result from air pressure.

Personal injury can result without following proper procedure. When using pressure air, wear a protective face shield and protective clothing.

Maximum air pressure at the nozzle must be less than 205 kPa (30 psi) for cleaning purposes.

After cleaning, start the engine and accelerate the engine to high idle rpm. This will help in the removal of debris and drying of the core. Stop the engine. Use a light bulb behind the core in order to inspect the core for cleanliness. Repeat the cleaning, if necessary.

Inspect the fins for damage. Bent fins may be opened with a "comb".

Note: If parts of the aftercooler system are repaired or replaced, a leak test is highly recommended.

Inspect these items for good condition: Welds, mounting brackets, air lines, connections, clamps and seals. Make repairs, if necessary.

i02322311

Alternator - Inspect

Perkins recommends a scheduled inspection of the alternator. Inspect the alternator for loose connections and correct battery charging. Check the ammeter (if equipped) during engine operation in order to ensure correct battery performance and/or correct performance of the electrical system. Make repairs, as required.

Check the alternator and the battery charger for correct operation. If the batteries are correctly charged, the ammeter reading should be very near zero. All batteries should be kept charged. The batteries should be kept warm because temperature affects the cranking power. If the battery is too cold, the battery will not crank the engine. When the engine is not run for long periods of time or if the engine is run for short periods, the batteries may not fully charge. A battery with a low charge will freeze more easily than a battery with a full charge.

i08696223

Alternator and Fan Belts - Replace (Multi-V Stretch Belt)

Removal Procedure

NOTICE

Keep all parts clean from contaminants.

Contaminants may cause rapid wear and shortened component life.

1. If the engine is equipped with fan guards, remove the fan guards. Refer to the Original Equipment Manufacture (OEM) for the correct procedure.

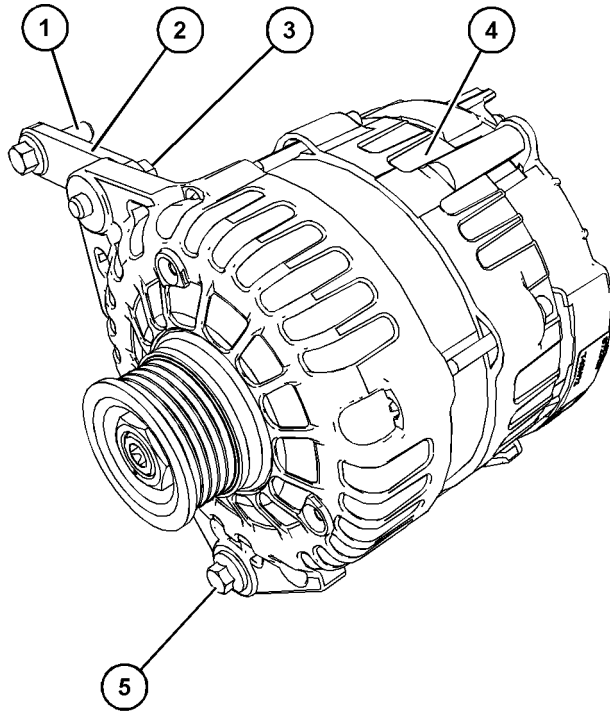

Illustration 69

g06473107

Typical example

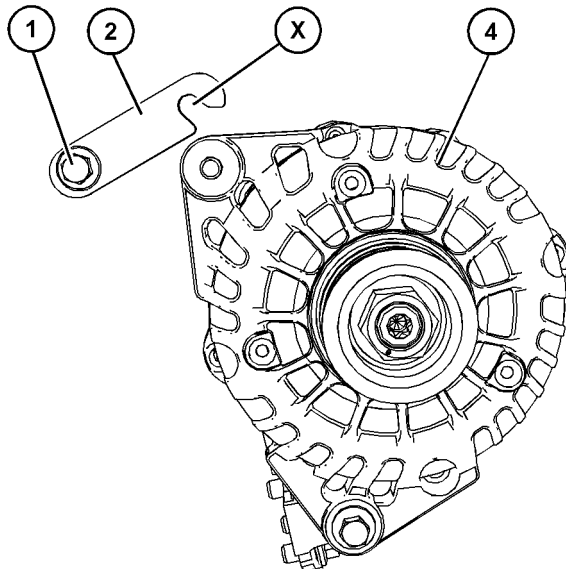

Illustration 70

g06474305

2. Make a note of the alternator belt routing for installation purposes.
3. Loosen bolt (1) and bolt (3) on link lever (2).
4. Loosen bolt (5).

5. Rotate link lever (2) anti-clockwise to release bolt (3) from the cut-out in Position (X).
6. Rotate alternator (4) towards the cylinder block to remove the alternator belt. Discard the alternator belt.

Installation Procedure

NOTICE

Keep all parts clean from contaminants.

Contaminants may cause rapid wear and shortened component life.

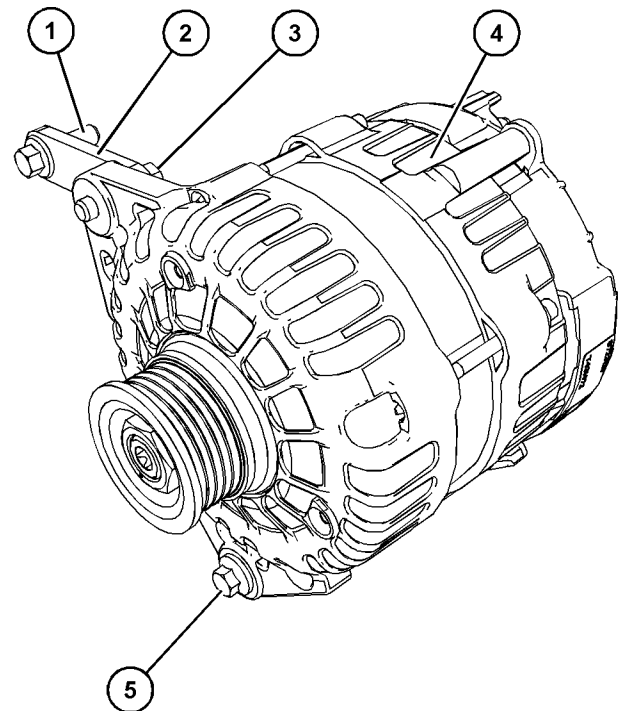

Illustration 71

g06473107

Typical example

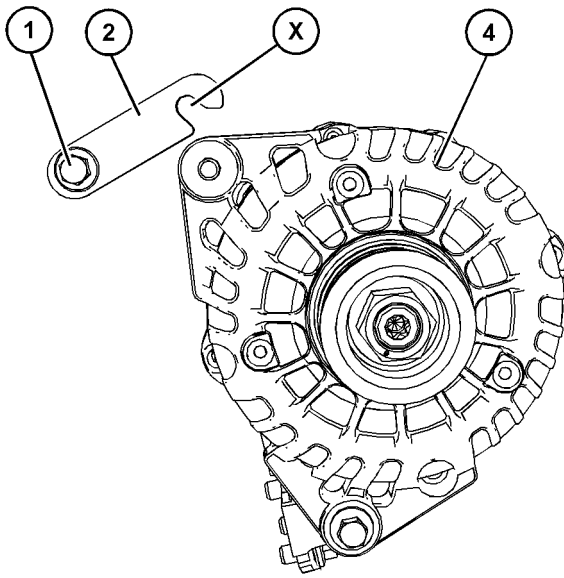

Illustration 72

g06474305

1. Position the new alternator belt onto all the pulleys.
2. Use a suitable tool to position the alternator away from the cylinder block engage the cut-out in Position (X) in link lever (2) with bolt (3). Tighten bolt (3).

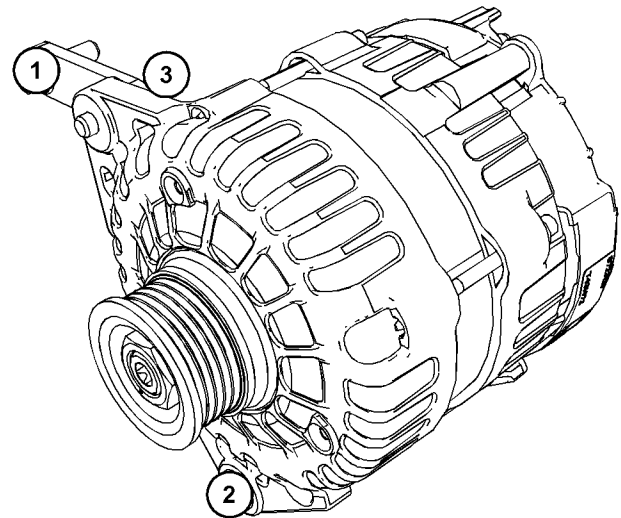

Illustration 73

g06474149

3. Tighten bolt (1), bolt (5), and bolt (3) in the sequence shown in Illustration 73 to a torque of 22 N·m (195 lb in)
4. If the engine is equipped with fan guards, install the fan guards. Refer to the Original Equipment Manufacture (OEM) for the correct procedure.

Engines Equipped with a Balancer

If the engine is equipped with Balancer, the alternator is supplied by the OEM. Refer to the OEM for the correct removal and installation procedures.

Maintenance Section
 Alternator and Fan Belts - Replace

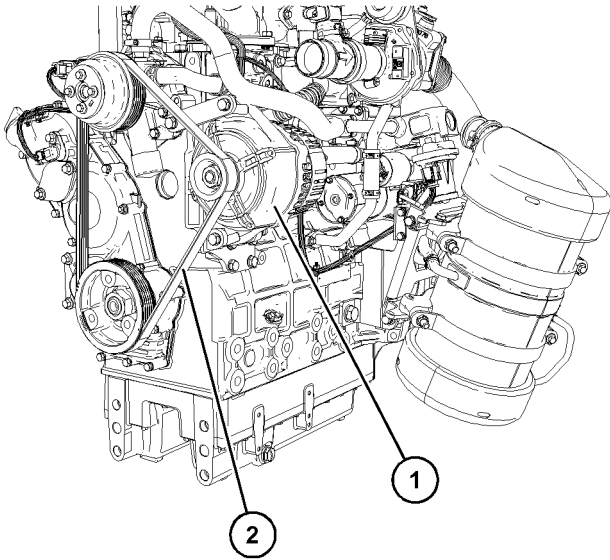

Illustration 74

g06546562

Typical example of an engine equipped with a balancer

- (1) Alternator
- (2) Alternator Belt

i08796317

Alternator and Fan Belts - Replace (Single-V Belt)

Removal Procedure

1. If the engine is equipped with fan guards, remove the fan guards. Refer to your Perkins dealer for further assistance.

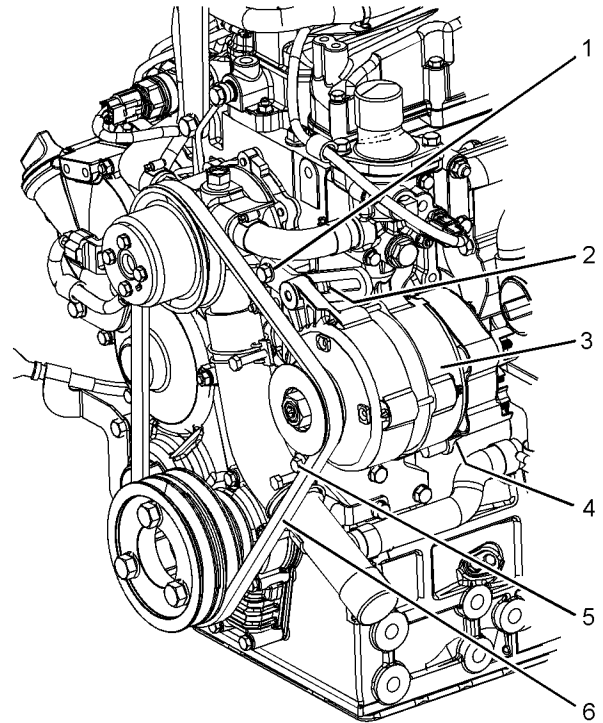

Illustration 75

g06540190

Typical example

2. Loosen bolt (1) and bolt (2) (not shown) on the adjuster link.
3. Loosen nut (4) (not shown) and bolt (5).

4. Push alternator (3) toward the engine and remove alternator belt (6).

Installation Procedure

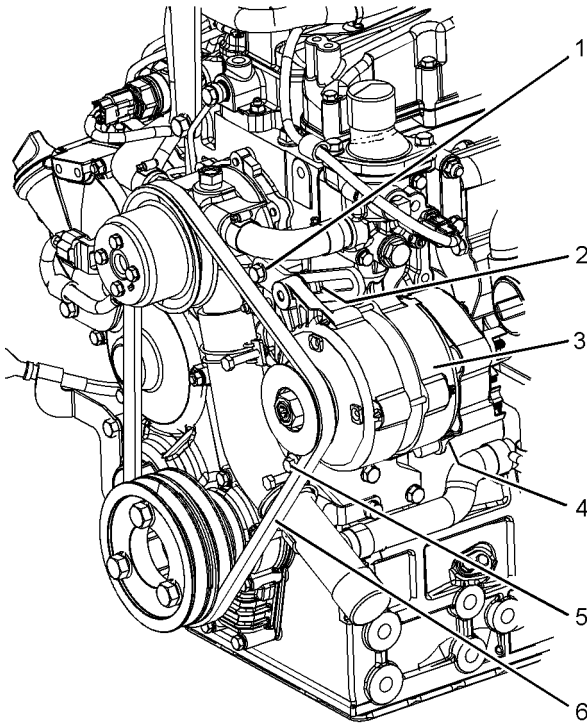

Illustration 76

g06540190

Typical example

1. Position alternator belt (6) onto alternator (3), the water pump pulley, and the crankshaft pulley. Ensure that the alternator belt is correctly positioned onto the alternator pulley, the water pump pulley, and the crankshaft pulley, refer to Illustration 75 .
2. Slide alternator (3) away from the engine to tighten belt (6) to the correct tension.

The belt tension for a new belt is from 400 N to 489 N (90 lb to 110 lb).
3. Tighten bolt (1), bolt (2) to a torque of 25 N·m (221 lb in).
4. Tighten nut (4) (not shown) and bolt (5) to a torque of 25 N·m (221 lb in).
5. If the engine is equipped with fan guards, install the fan guards. Refer to your Perkins dealer for further assistance.

Note: When a new belt is installed, check the belt tension again after 20 hours of engine operation.

For applications that require multiple drive belts, replace the belts in matched sets.

i02322315

Battery - Replace

⚠ WARNING

Batteries give off combustible gases which can explode. A spark can cause the combustible gases to ignite. This can result in severe personal injury or death.

Ensure proper ventilation for batteries that are in an enclosure. Follow the proper procedures in order to help prevent electrical arcs and/or sparks near batteries. Do not smoke when batteries are serviced.

⚠ WARNING

The battery cables or the batteries should not be removed with the battery cover in place. The battery cover should be removed before any servicing is attempted.

Removing the battery cables or the batteries with the cover in place may cause a battery explosion resulting in personal injury.

1. Switch the engine to the OFF position. Remove all electrical loads.
 2. Turn off any battery chargers. Disconnect any battery chargers.
 3. The NEGATIVE “-” cable connects the NEGATIVE “-” battery terminal to the NEGATIVE “-” terminal on the starting motor. Disconnect the cable from the NEGATIVE “-” battery terminal.
 4. The POSITIVE “+” cable connects the POSITIVE “+” battery terminal to the POSITIVE “+” terminal on the starting motor. Disconnect the cable from the POSITIVE “+” battery terminal.
- Note:** Always recycle a battery. Never discard a battery. Dispose of used batteries to an appropriate recycling facility.
5. Remove the used battery.
 6. Install the new battery.
- Note:** Before the cables are connected, ensure that the engine start switch is OFF.
7. Connect the cable from the starting motor to the POSITIVE “+” battery terminal.

8. Connect the NEGATIVE “-” cable to the NEGATIVE “-” battery terminal.

i09570426

i02747977

Battery Electrolyte Level - Check

When the engine is not run for long periods of time or when the engine is run for short periods, the batteries may not fully recharge. Ensure a full charge in order to help prevent the battery from freezing. If batteries are correctly charged, the ammeter reading should be very near zero, when the engine is in operation.

WARNING

All lead-acid batteries contain sulfuric acid which can burn the skin and clothing. Always wear a face shield and protective clothing when working on or near batteries.

1. Remove the filler caps. Maintain the electrolyte level to the “FULL” mark on the battery.

If the addition of water is necessary, use distilled water. If distilled water is not available use clean water that is low in minerals. Do not use artificially softened water.

2. Check the condition of the electrolyte with a suitable battery tester.
3. Install the caps.
4. Keep the batteries clean.

Clean the battery case with one of the following cleaning solutions:

- Use a solution of 0.1 kg (0.2 lb) baking soda and 1 L (1 qt) of clean water.
- Use a solution of ammonium hydroxide.

Thoroughly rinse the battery case with clean water.

Battery or Battery Cable - Disconnect

WARNING

The battery cables or the batteries should not be removed with the battery cover in place. The battery cover should be removed before any servicing is attempted.

Removing the battery cables or the batteries with the cover in place may cause a battery explosion resulting in personal injury.

1. Turn the start switch to the OFF position. Turn the ignition switch (if equipped) to the OFF position and remove the key and all electrical loads.
2. Open the battery isolator. Disconnect the negative battery terminal. Ensure that the cable cannot contact the terminal. When four 12 volt batteries are involved, two negative connections must be disconnected.
3. Remove the positive connection.
4. Clean all disconnected connection and battery terminals.
5. Use a fine grade of sandpaper to clean the terminals and the cable clamps. Clean the items until the surfaces are bright or shiny. DO NOT remove material excessively. Excessive removal of material can cause the clamps to not fit correctly. Coat the clamps and the terminals with a suitable silicone lubricant or petroleum jelly.
6. Tape the cable connections to help prevent accidental starting.
7. Proceed with necessary system repairs.
8. To connect the battery, connect the positive connection before the negative connection.

i08108488

Belts - Inspect/Adjust

Inspection

To maximize the engine performance, inspect the belt for wear and for cracking. Replace a belt that is worn or damaged.

If the belt is too loose, vibration causes unnecessary wear on the belt and pulleys. A loose belt may slip enough to cause overheating.

The correct tension for a new belt is 400 N (90 lb) to 489 N (110 lb). The correct tension for a used belt that has been in operation for 30 minutes or more at the rated speed is 267 N (60 lb) to 356 N (80 lb).

The belt tension should be checked at the center point of the belt between the pulleys.

Adjust

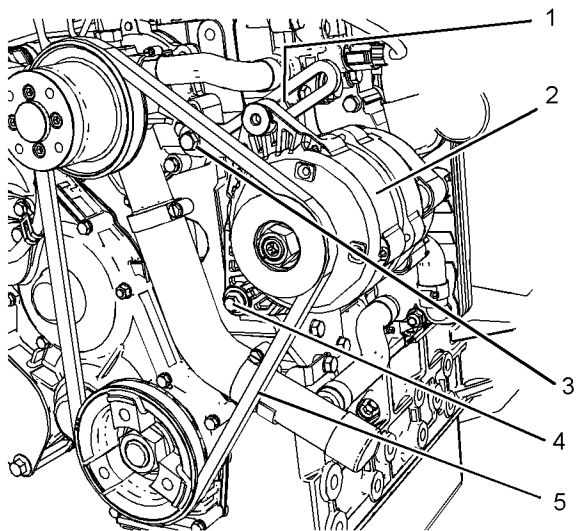

Illustration 77

g03886616

Typical example

1. Loosen bolt (1) and loosen bolt (3).
2. Loose nut and bolt (4).
3. Move the alternator (2) to adjust the belt (4) to the required tension.
4. Tighten bolt (1) and bolt (3) to a torque of 22 N·m (194 lb in). Tighten nut and bolt (4) to a torque of 22 N·m (194 lb in).

Engines Equipped with a Balancer

If the engine is equipped with a balancer, the alternator is supplied by the Original Equipment Manufacturer (OEM). The belt adjustment procedure will be provided by the OEM. Refer to the OEM for the correct inspect and adjust procedures.

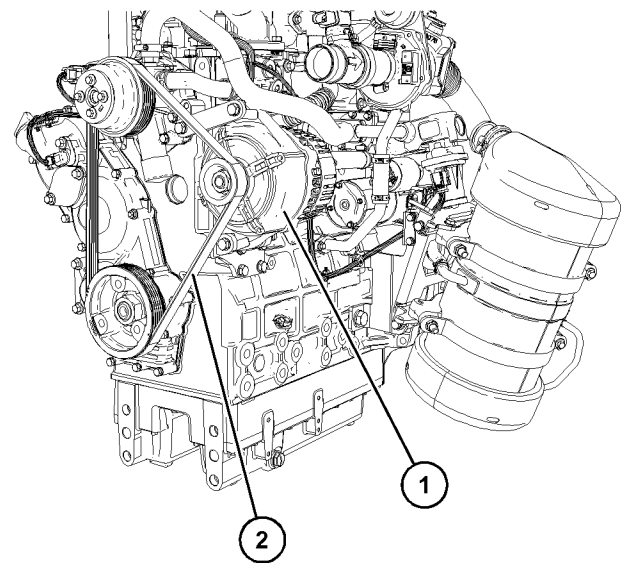

Illustration 78

g06546562

Typical example of an engine equipped with a balancer

- () Alternator
- () Alternator Belt

i09870049

Coolant (Commercial Heavy-Duty) - Change

Clean the cooling system and flush the cooling system before the recommended maintenance interval if the following conditions exist:

- The engine overheats frequently.
- Foaming is observed.
- The oil has entered the cooling system and the coolant is contaminated.
- The fuel has entered the cooling system and the coolant is contaminated.

NOTICE

When any servicing or repair of the engine cooling system is performed, the procedure must be performed with the engine on level ground. Level ground will allow you to check accurately the coolant level. This procedure will also help in avoiding the risk of introducing an air lock into the coolant system.

Note: Inspect the water pump and the water temperature regulator after the cooling system has been drained. This inspection is a good opportunity to replace the water pump, the water temperature regulator, and the hoses, if necessary.

Drain

WARNING

Pressurized System: Hot coolant can cause serious burns. To open the cooling system filler cap, stop the engine and wait until the cooling system components are cool. Loosen the cooling system pressure cap slowly in order to relieve the pressure.

1. Stop the engine and allow the engine to cool.
Loosen the cooling system filler cap slowly to relieve any pressure. Remove the cooling system filler cap.

Note: Refer to Operation and Maintenance Manual, "General Hazard Information" for information on Containing Fluid Spillage.

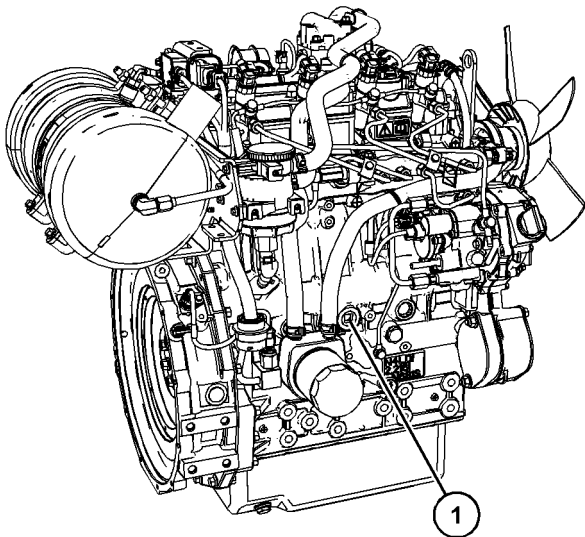

Illustration 79

g06310215

Typical example

2. Remove drain plug (1) on the engine. Open the drain cock or remove the drain plug on the radiator.

Allow the coolant to drain into a suitable container.

3. Properly dispose of the drained material. Obey local regulations for the disposal of the material.

Drain Plugs for IOPU Radiators

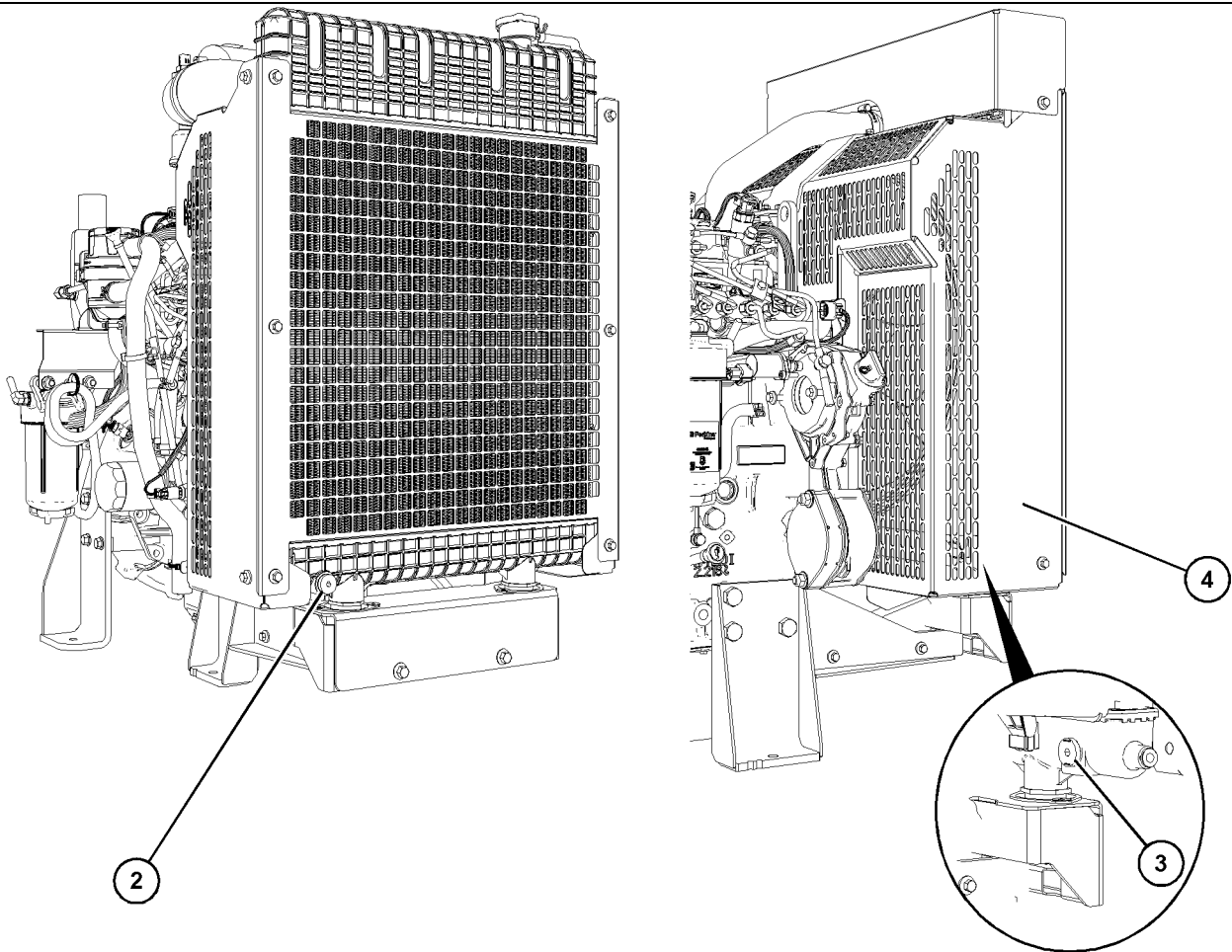

Illustration 80

g07522440

Typical example

- (2) Three cylinder IOPU radiator drain plug (3) Four cylinder IOPU radiator drain plug

Remove fan guard (4) to get access to the drain plug (3) for the 404J-E22T 4 cylinder IOPU radiator.

- Tighten drain plug (2) and drain plug (3) to a torque of 4 N·m (35.4 lb in)

Drain Plugs for Factory Installed Radiators

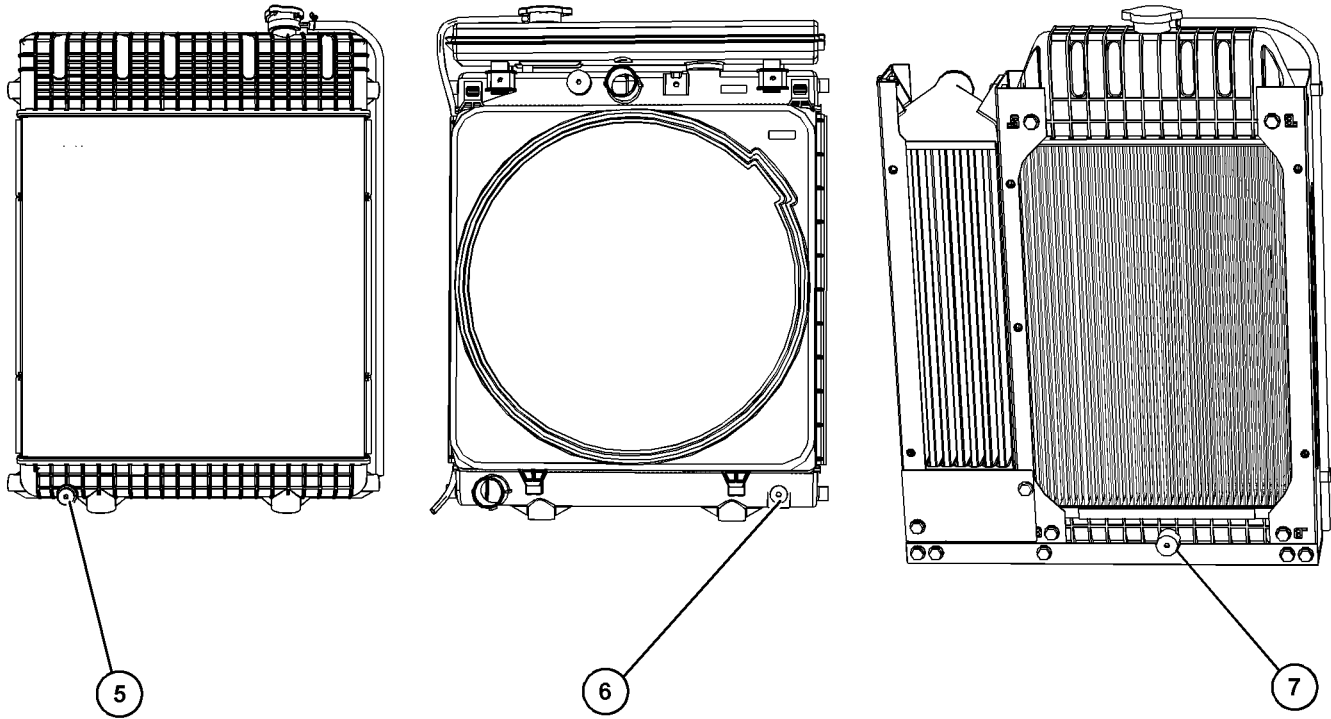

Illustration 81

g07536716

Typical example

(5) Three cylinder engine radiator drain plug

(6) Four cylinder turbocharged engine radiator drain plug

(7) Four cylinder turbocharged aftercooled engine drain plug front of radiator

- Tighten drain plug (5) to a torque of 4 N·m (35.4 lb in)
- Tighten drain plug (6) to a torque of 4 N·m (35.4 lb in)

- Tighten drain plug (7) to a torque of 6 N·m (53. lb in)

Drain Plug for ElectropaK Radiator

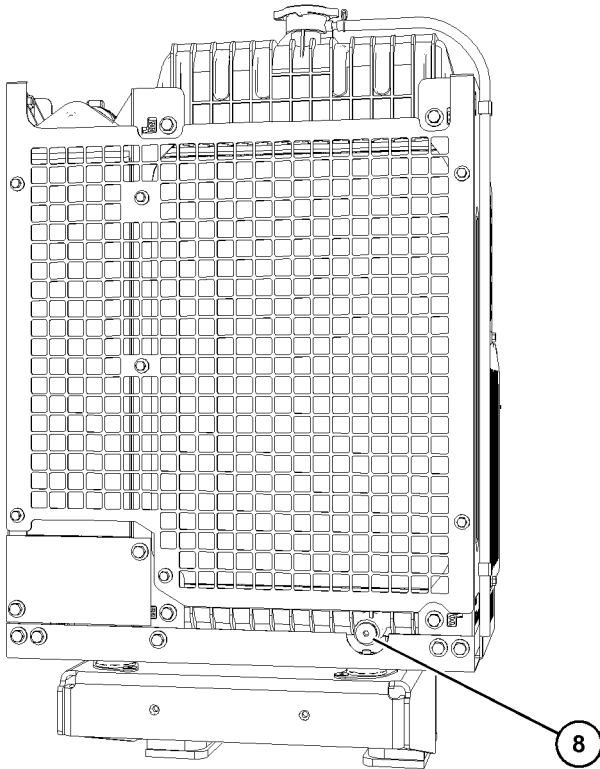

Illustration 82

g07626417

Typical example

- (8) Four cylinder turbocharged aftercooled engine, ElectropaK radiator drain plug

Tighten drain plug (8) to a torque of 6 N·m (53. lb in)

Flush

1. Flush the cooling system with clean water and a suitable cleaning agent to remove any debris. Refer to your Perkins dealer or distributor for suitable cleaning agents.
2. Install connection hose. Clean the drain plugs. Install the drain plugs. Tighten drain plug securely.

NOTICE

Do not fill the cooling system faster than 5 L (1.3 US gal) per minute to avoid air locks.

Cooling system air locks may result in engine damage.

3. Fill the cooling system with clean water and install the cooling system filler cap.

4. Start and run the engine at low idle for a minimum of 30 minutes. The coolant temperature should be at least 82 °C (180 °F).

NOTICE

Improper or incomplete rinsing of the cooling system can result in damage to copper and other metal components.

To avoid damage to the cooling system, make sure to completely flush the cooling system with clear water. Continue to flush the system until all signs of the cleaning agent are gone.

5. Stop the engine and allow the engine to cool. Loosen the cooling system filler cap slowly to relieve any pressure. Remove the cooling system filler cap. Remove the connection hose or remove the cooling system drain plugs. Allow the water to drain. Flush the cooling system with clean water. Install the connection hose. Install all drain plugs and tighten securely.

Fill

NOTICE

Do not fill the cooling system faster than 5 L (1.3 US gal) per minute to avoid air locks.

Cooling system air locks may result in engine damage.

1. Fill the cooling system with the coolant/antifreeze. Refer to this Operation and Maintenance Manual, "Refill Capacities and Recommendations" topic (Maintenance Section) for more information on cooling system specifications. Do not install the cooling system filler cap.
2. Start and run the engine at low idle. Increase the engine rpm to high idle. Operate the engine to open the engine thermostat. This operation will allow any air in the system to be purged. Decrease the engine speed to low idle. Stop the engine.
3. Maintain the coolant level at the maximum mark that is correct for your application. Refer to this Operation and Maintenance Manual, "Coolant Level - Check" for more information.

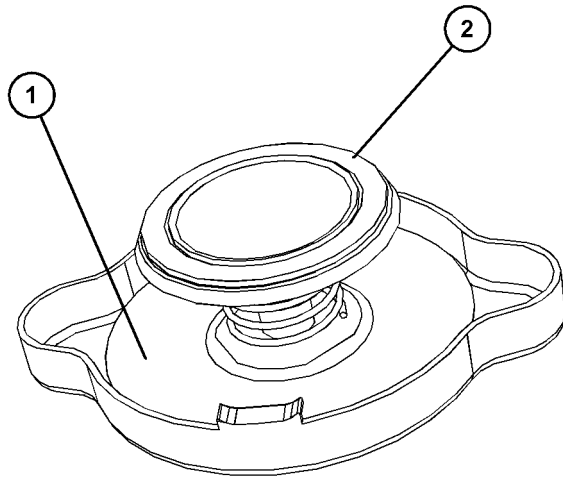

Illustration 83

g06165279

Typical example

4. Clean the cooling system filler cap and check the condition of the filler cap gasket (2). Replace the cooling system filler cap if the filler cap gasket (2) and sealing surface (1) are damaged. If the cooling system filler cap is not damaged, perform a pressure test on the filler cap.

IOPU radiators

The cooling system filler cap pressure for IOPU radiators on both the three cylinder engine and four cylinder engine is 110 kPa (15.9 psi).

Factory installed radiators

- Radiator cap pressure for both the three cylinder engine and four cylinder engine is 110 kPa (15.9 psi).

If the cooling system filler cap passes the pressure test check, install the filler cap. If required install new cooling system filler cap.

5. Start the engine. Inspect the cooling system for leaks and for the correct operating temperature.

i09870079

Coolant (ELC) - Change

Clean the cooling system and flush the cooling system before the recommended maintenance interval if the following conditions exist:

- The engine overheats frequently.

- Foaming is observed.
- The oil has entered the cooling system and the coolant is contaminated.
- The fuel has entered the cooling system and the coolant is contaminated.

Note: When the cooling system is cleaned, only clean water is needed when the ELC is drained and replaced.

Note: Inspect the water pump and the water temperature regulator after the cooling system has been drained. Replace the water pump, the water temperature regulator, and the hoses, if necessary.

NOTICE

Service or repair of the engine cooling system must be performed on level ground. The engine must be level to check the coolant level. The engine must be level to avoid the risk of introducing an air lock into the coolant system.

Drain

WARNING

Pressurized System: Hot coolant can cause serious burns. To open the cooling system filler cap, stop the engine and wait until the cooling system components are cool. Loosen the cooling system pressure cap slowly in order to relieve the pressure.

1. Stop the engine and allow the engine to cool. Loosen the cooling system filler cap slowly to relieve any pressure. Remove the cooling system filler cap.

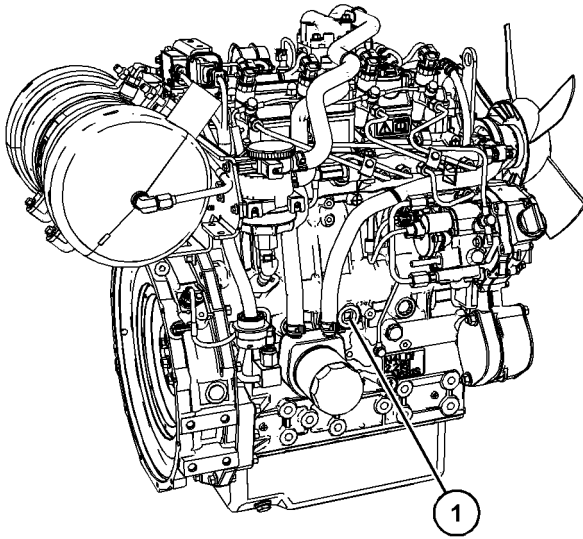

Illustration 84

g06310215

Typical example

2. Remove drain plug (1) on the engine. Open the drain cock or remove the drain plug on the radiator.

Allow the coolant to drain.

For information regarding the disposal and the recycling of used coolant, consult your Perkins distributor.

Drain Plugs for IOPU Radiators

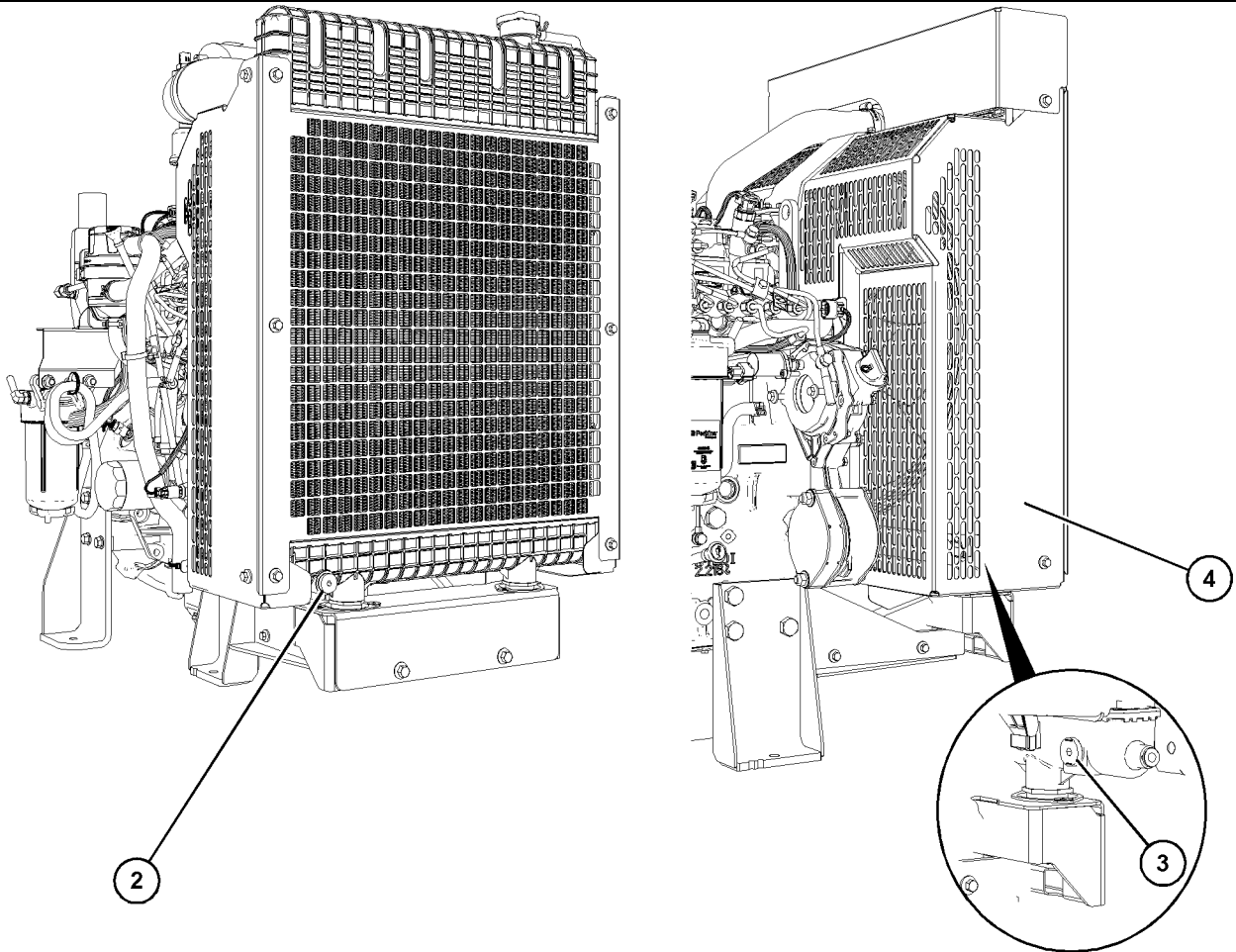

Illustration 85

g07522440

Typical example

(2) Three cylinder IOPU radiator drain plug (3) Four cylinder IOPU radiator drain plug

Remove fan guard (4) to get access to the drain plug (3) for the 404J-E22T 4 cylinder IOPU radiator.

- Tighten drain plug (2) and drain plug (3) to a torque of 4 N·m (35.4 lb in)

Drain Plugs for Factory Installed Radiators

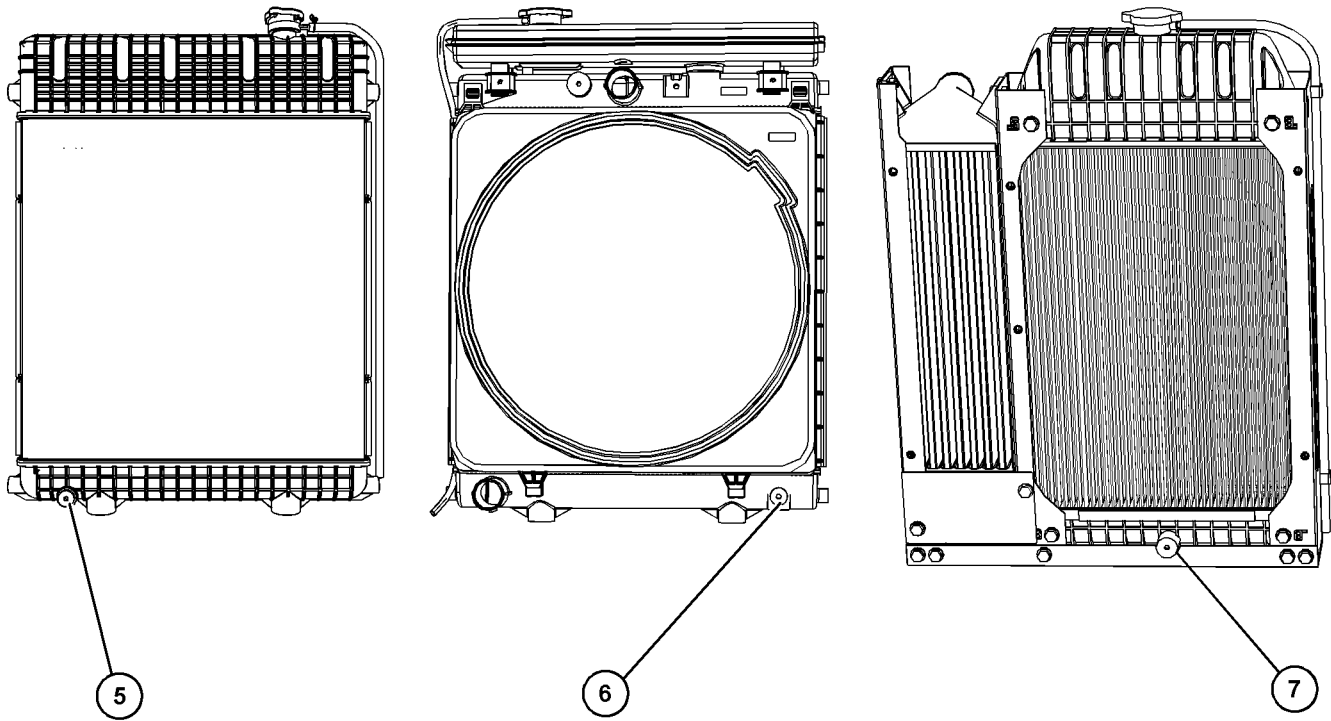

Illustration 86

g07536716

Typical example

(5) Three cylinder radiator drain plug

(6) Four cylinder turbocharged engine radiator drain plug

(7) Four cylinder turbocharged aftercooled engine drain plug front of radiator

- Torque drain plug (5) to a torque of 4 N·m (35.4 lb in)
- Torque drain plug (6) to a torque of 4 N·m (35.4 lb in)

- Torque drain plug (7) to a torque of 6 N·m (53. lb in)

Drain Plug for ElectropaK Radiator

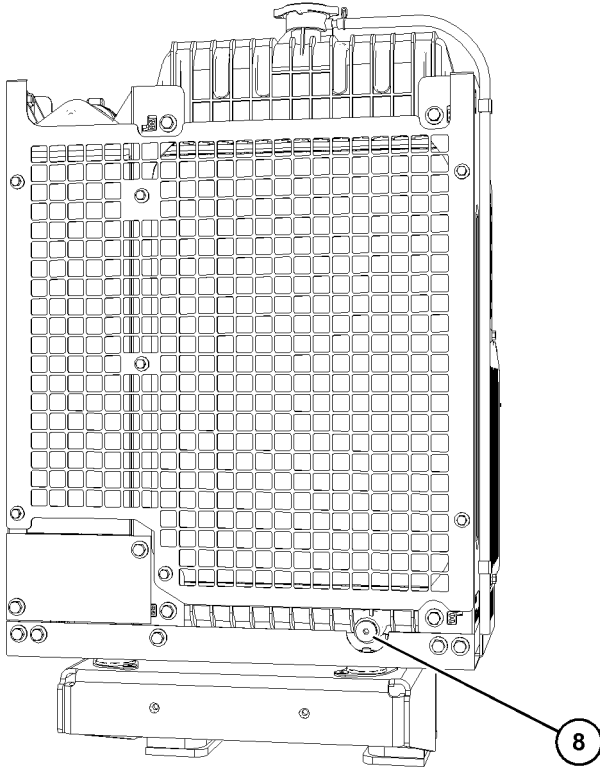

Illustration 87

g07626417

Typical example

(8) Four cylinder turbocharged aftercooled engine, ElectropaK radiator drain plug

Tighten drain plug (8) to a torque of 6 N·m (53. lb in)

Flush

1. Flush the cooling system with distilled or deionized water to remove any debris.
2. Install the connection hose. Clean the drain plugs and install the drain plugs. Tighten the drain plugs securely.

NOTICE

Do not fill the cooling system faster than 5 L (1.3 US gal) per minute to avoid air locks.

Cooling system air locks may result in engine damage.

3. Fill the cooling system with distilled or deionized water. Install the cooling system filler cap.

4. Start and run the engine at low idle until the temperature reaches 49 to 66 °C (120 to 150 °F).
5. Stop the engine and allow the engine to cool. Loosen the cooling system filler cap slowly to relieve any pressure. Remove the cooling system filler cap. Remove the cooling system drain plugs. Allow the water to drain. Flush the cooling system with clean water. Install the cooling system drain plugs and tighten securely.

Fill

NOTICE

Do not fill the cooling system faster than 5 L (1.3 US gal) per minute to avoid air locks.

Cooling system air locks may result in engine damage.

1. Fill the cooling system with Extended Life Coolant (ELC). Refer to this Operation and Maintenance Manual, "Refill Capacities" topic (Maintenance Section) for more information on cooling system specifications. Do not install the cooling system filler cap.
2. Start and run the engine at low idle. Increase the engine rpm to high idle. Operate the engine to open the engine thermostat. An open thermostat will allow any air in the system to be purged. Decrease the engine speed to low idle. Stop the engine.
3. Maintain the coolant level at the maximum mark that is correct for your application. For more information, refer to this Operation and Maintenance Manual, "Coolant Level - Check".

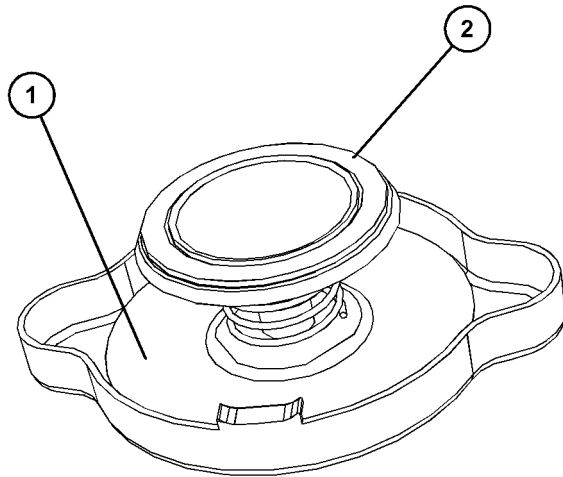

Illustration 88

g06165279

Typical example

4. Clean the cooling system filler cap and check the condition of the filler cap gasket (2). Replace the cooling system filler cap if the filler cap gasket (2) and sealing surface (1) are damaged. If the cooling system filler cap is not damaged, perform a pressure test on the filler cap.

IOPU radiators

The cooling system filler cap pressure for IOPU radiators on both the three cylinder engine and four cylinder engine is 110 kPa (15.9 psi).

Factory installed radiators

- Radiator cap pressure for both the three cylinder engine and four cylinder engine is 110 kPa (15.9 psi).

If the cooling system filler cap passes the pressure test check, install the filler cap. If required install new cooling system filler cap.

5. Start the engine. Inspect the cooling system for leaks and for proper operating temperature.

i09660369

Coolant Level - Check

WARNING

Pressurized System: Hot coolant can cause serious burns. To open the cooling system filler cap, stop the engine and wait until the cooling system components are cool. Loosen the cooling system pressure cap slowly in order to relieve the pressure.

Check the coolant level when the engine is stopped and cool.

NOTICE

When any servicing or repair of the engine cooling system is performed, the procedure must be performed with the engine on level ground. This procedure will allow you to check accurately the coolant level. This procedure will also help in avoiding the risk of introducing an air lock into the coolant system.

Remove the cooling system filler cap slowly to relieve the pressure within the cooling system.

For the correct coolant level, refer to the OEM information.

Industrial Open Power Unit (IOPU) Radiators

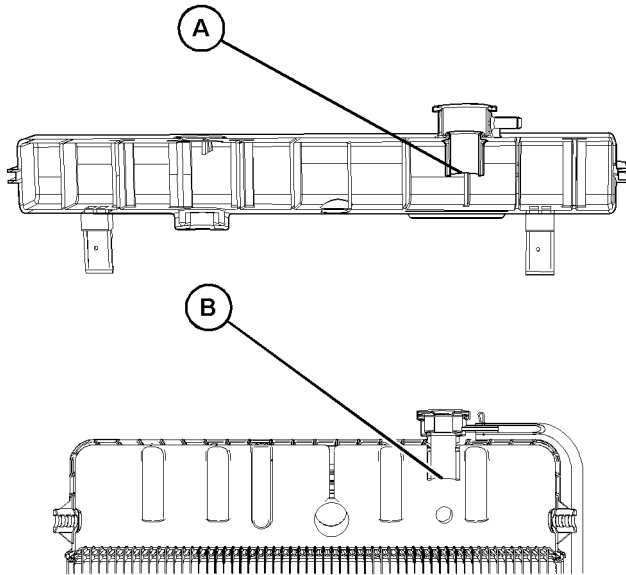

Illustration 89

g07532081

Typical example

- The coolant level (A) is for four cylinder turbocharged IOPU radiator.
- The coolant level (B) is for three cylinder turbocharged IOPU radiator.

Coolant levels for IOPU radiators should be in line with the bottom of the filler neck.

Factory Installed Radiators

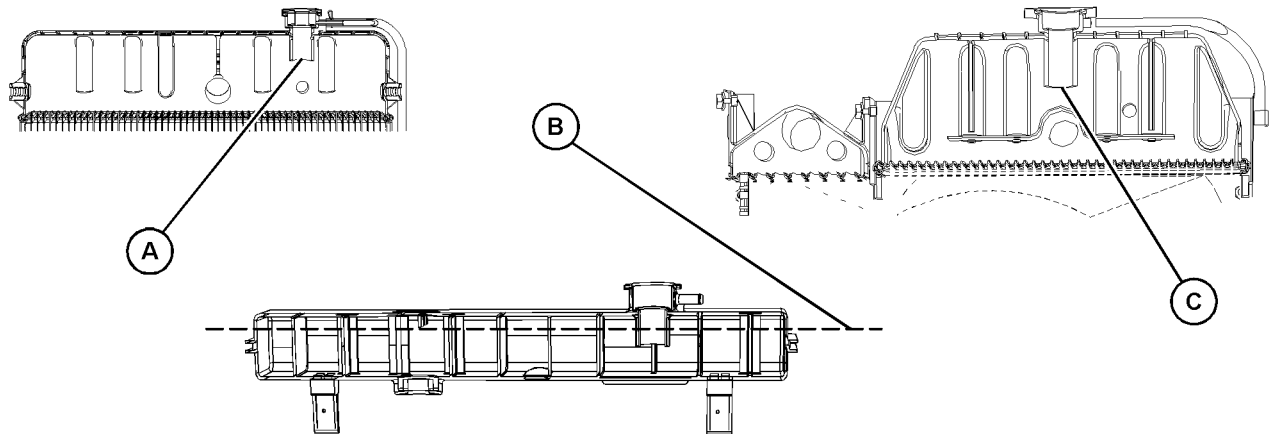

Illustration 90

g07537228

Typical example

- The coolant level (A) is for factory installed radiator with the three cylinder engine.
- The coolant level (B) is for factory installed radiator with the four cylinder turbocharged engine.
- The coolant level (C) is for factory installed radiator with the four cylinder turbocharged aftercooled engine.

Note: The coolant level (C) for the four cylinder turbocharged engine is different from three cylinder and the four cylinder turbocharged aftercooled engines. The four cylinder turbocharged engine coolant level (B) is 20 mm (0.78740 inch) below the top of the radiator neck.

Radiator Cap for Factory Installed Radiators

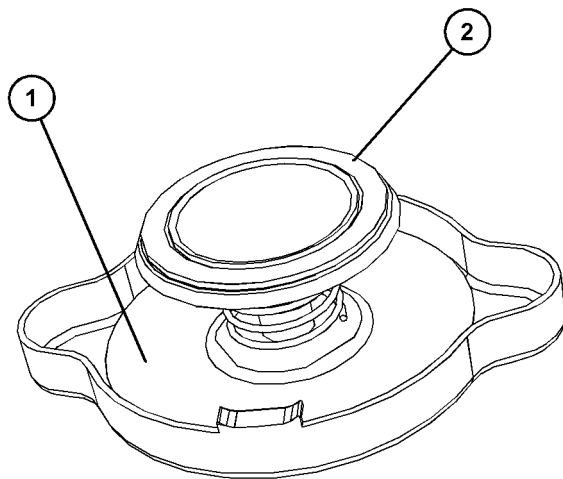

Illustration 91

g06165279

Typical example

Clean the cooling system filler cap and check the condition of the filler cap gasket (1). Replace the cooling system filler cap if the filler cap gasket (2) or the sealing surface (1) are damaged.

The radiator filler cap should be checked at regular intervals to insure that the filler cap relieve pressure is correct. The cooling system fill cap pressure is:

- Cooling system filler cap pressure for both the three cylinder engine and four cylinder engine is 110 kPa (15.9 psi)

Reinstall the cooling system filler cap when all checks are complete.

Radiator Cap for IOPU Radiators

The radiator filler cap should be checked at regular intervals to insure that the filler cap relieve pressure is correct. The cooling system filler cap pressure for IOPU radiators on both the three cylinder engine and four cylinder engine is 110 kPa (15.9 psi).

i06296588

Coolant Temperature Regulator - Replace

Replace the water temperature regulator before the water temperature regulator fails. This is a recommended preventive maintenance practice. Replacing the water temperature regulator reduces the chances for unscheduled downtime.

A water temperature regulator that fails in a partially opened position can cause overheating or overcooling of the engine.

A water temperature regulator that fails in the closed position can cause excessive overheating. Excessive overheating could result in cracking of the cylinder head or piston seizure problems.

A water temperature regulator that fails in the open position will cause the engine operating temperature to be too low during partial load operation. Low engine operating temperatures during partial loads could cause an excessive carbon buildup inside the cylinders. This excessive carbon buildup could result in an accelerated wear of the piston rings and wear of the cylinder liner.

NOTICE

Failure to replace your water temperature regulator on a regularly scheduled basis could cause severe engine damage.

Perkins engines incorporate a shunt design cooling system and require operating the engine with a water temperature regulator installed.

If the water temperature regulator is installed incorrectly, the engine may overheat, causing cylinder head damage. Ensure that the new water temperature regulator is installed in the original position. Ensure that the water temperature regulator vent hole is open.

Do not use liquid gasket material on the gasket or cylinder head surface.

Refer to the Disassembly and Assembly Manual, "Water Temperature Regulator - Remove and Install" for the replacement procedure of the water temperature regulator, or consult your Perkins dealer or your Perkins distributor.

Note: If only the water temperature regulators are replaced, drain the coolant from the cooling system to a level that is below the water temperature regulator housing.

i08791111

Crankcase Breather (Element) - Replace (Closed Crankcase Breather)

WARNING

Hot oil and hot components can cause personal injury. Do not allow hot oil or hot components to contact the skin.

NOTICE

Ensure that the engine is stopped before any servicing or repair is performed.

NOTICE

Care must be taken to ensure that fluids are contained during performance of inspection, maintenance, testing, adjusting and repair of the product. Be prepared to collect the fluid with suitable containers before opening any compartment or disassembling any component containing fluids.

Dispose of all fluids according to local regulations and mandates.

The crankcase breather plays a major role in keeping your engine emissions compliant.

- The filter element within the crankcase breather must be serviced at the prescribed service interval.
- The correct filter element must be installed before the engine is operated.
- The installation of the filter element is critical to the correct operation of the engine.
- The quality of the filter element that is installed is very important, Perkins recommend using genuine Perkins filters.

- The filter element protects the engine from excessive quantities of oil from entering the induction system. The filter element also protects the engine aftertreatment system.

Note: Excessive quantities of oil that enter the induction system of the engine can rapidly increase the engine speed without control.

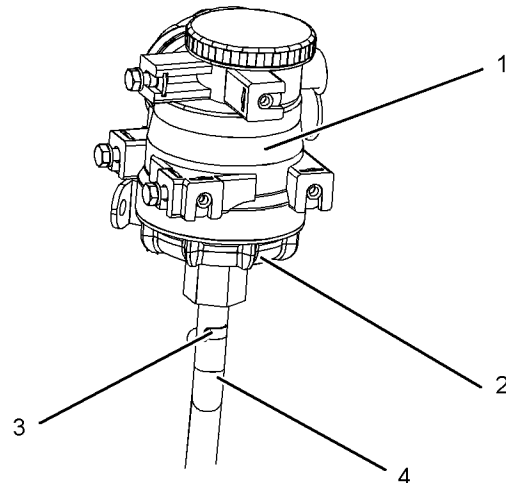

Illustration 92

g03331718

Typical example

1. Ensure that dirt cannot enter the breather assembly. Ensure that the outside body of the breather assembly is clean and free from damage. Place a container under the breather assembly.
2. Make temporary marks on hose (4) to identify the correct orientation for installation purposes.

Note: A one-way valve is installed into the hose, incorrectly installing the hose can cause catastrophic engine failure.

3. Remove clip (3) and remove hose (4) from cap (2). Remove cap (2) from the main body (1).

Maintenance Section
Crankcase Breather (Element) - Replace

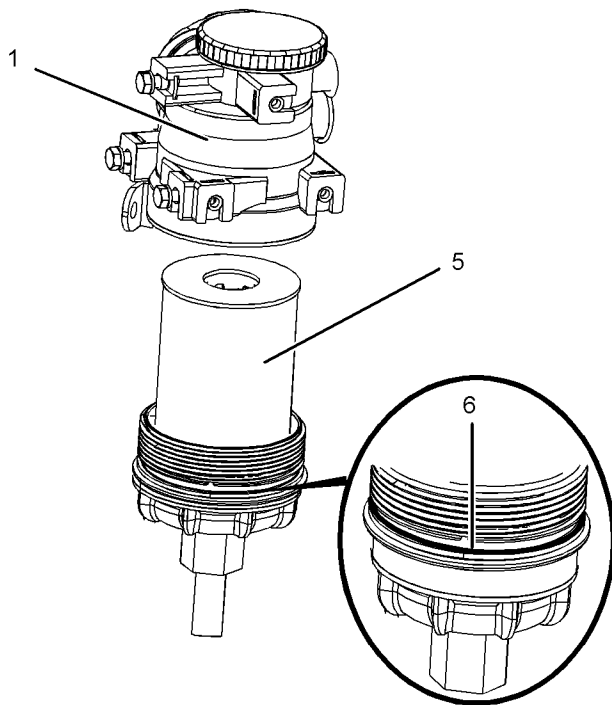

Illustration 93

g03331704

Typical example

4. Remove filter element (5) and remove O ring seal (6) and discard.

Note: Ensure that all parts are clean and free from dirt and damage.

5. Apply clean engine oil to new O-ring seal (6). Install the O-ring seal onto cap (2).
6. Install a new filter element (5) into cap (2).
7. Install cap assembly into the main body (1). Tighten the cap assembly to 10 N·m (7 lb ft).

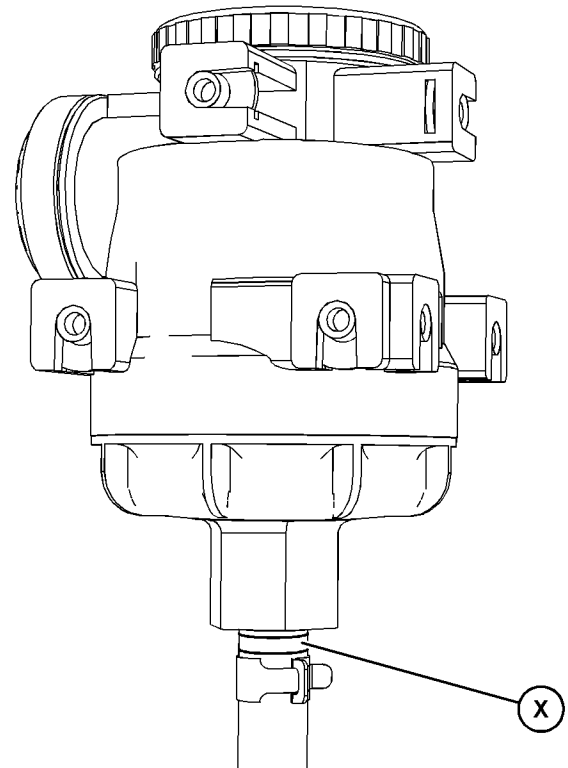

Illustration 94

g06477300

8. Install hose (4) and clip (3). Ensure that the hose is correctly orientated.

If a new hose is being installed, the end of the hose with the white band in Position (X) must be attached to the breather canister. Refer to Illustration 94 for the correct positioning.

Note: Incorrectly installing the hose can cause catastrophic engine failure.

9. Remove the container and clean away any split fluid.

i08791119

Crankcase Breather (Element) - Replace (Open Crankcase Breather)

WARNING

Hot oil and hot components can cause personal injury. Do not allow hot oil or hot components to contact the skin.

NOTICE

Ensure that the engine is stopped before any servicing or repair is performed.

NOTICE

Care must be taken to ensure that fluids are contained during performance of inspection, maintenance, testing, adjusting and repair of the product. Be prepared to collect the fluid with suitable containers before opening any compartment or disassembling any component containing fluids.

Dispose of all fluids according to local regulations and mandates.

The crankcase breather plays a major role in keeping your engine emissions compliant.

- The filter element within the crankcase breather must be serviced at the prescribed service interval.
- The correct filter element must be installed before the engine is operated.
- The installation of the filter element is critical to the correct operation of the engine.
- The quality of the filter element that is installed is very important, Perkins recommend using genuine Perkins filters.

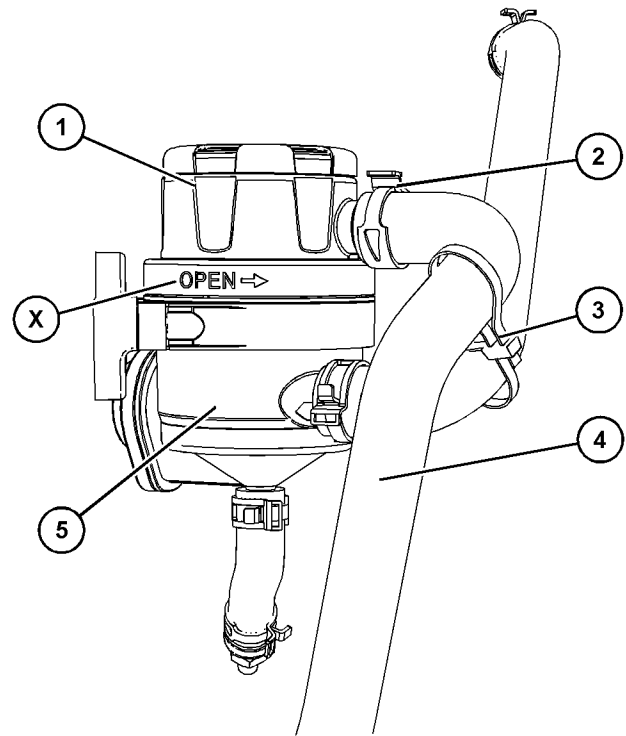

Illustration 95

g06773063

Typical example

1. Ensure that dirt cannot enter the breather assembly. Ensure that the outside body of the breather assembly is clean and free from damage. Place a container under the breather assembly.
2. Reposition hose clamp (2) to allow hose (4) to be disconnected. Discard hose clamp (2).

Note: The orientation of the breather canister assembly for 3 cylinder engines is different to the 4 cylinder engines.

3. If necessary, cut cable strap (3).
4. Disconnect hose (4) from cap (1).
5. Rotate cap (1) in a counter clockwise direction, as shown in Position (X) in Illustration 95 . Remove cap (1) from the main body (5).

i07819515

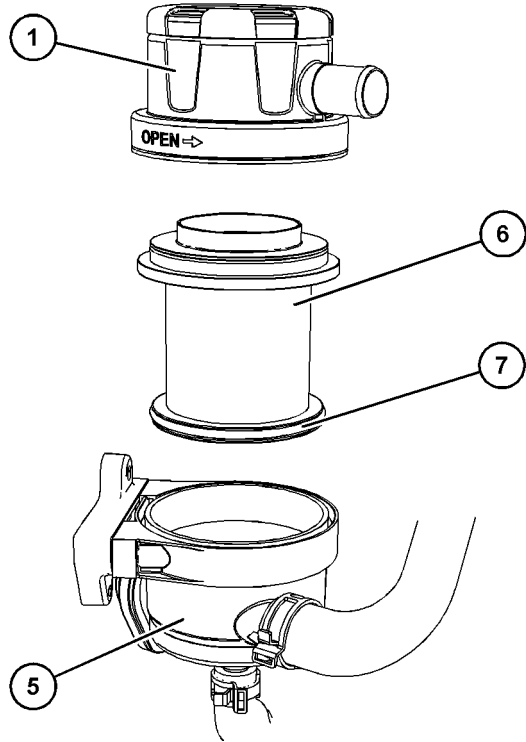

Illustration 96

g06773085

Typical example

6. Remove breather filter element (6) from main body (5). Discard the filter element.

Note: Ensure that all parts are clean and free from dirt and damage.

7. Apply clean engine oil to lower filter seal (7).

8. Install filter element (6) into main body (5).

Note: Ensure that the filter element is pushed down in the main body. The top seal should sit uniformly across the circumference of the main body.

9. Position cap assembly onto main body (5). Tighten the cap.

Note: Ensure that the top cap is correctly engaged to the main body.

10. Install new hose clamp (2) onto hose (4).

11. Connect hose (4) to cap (1). Secure the hose in position with hose clamp (2).

12. If necessary, install new cable strap (3)

13. Remove the container and clean away any spilt fluid.

Engine - Clean

WARNING

Personal injury or death can result from high voltage.

Moisture can create paths of electrical conductivity.

Make sure that the electrical system is OFF. Lock out the starting controls and tag the controls "DO NOT OPERATE" .

NOTICE

Accumulated grease and oil on an engine is a fire hazard. Keep the engine clean. Remove debris and fluid spills whenever a significant quantity accumulates on the engine.

Periodic cleaning of the engine is recommended. Steam cleaning the engine will remove accumulated oil and grease. A clean engine provides the following benefits:

- Easy detection of fluid leaks
- Maximum heat transfer characteristics
- Ease of maintenance

Note: Caution must be used to prevent electrical components from being damaged by excessive water when the engine is cleaned. Pressure washers and steam cleaners should not be directed at any electrical connectors or the junction of cables into the rear of the connectors. Avoid electrical components such as the alternator, the starter, and the ECM. Protect the fuel injection pump from fluids to wash the engine.

Ensure that care is taken that the safety labels, emission label, and all other information labels are not removed during engine cleaning.

Aftertreatment

During the engine cleaning process, ensure that water or cleaning fluids cannot enter the aftertreatment system. If cleaning fluids enters the aftertreatment system, damage could occur.

i09649631

Engine Air Cleaner Element - Replace

NOTICE

Never run the engine without an air cleaner element installed. Never run the engine with a damaged air cleaner element. Do not use air cleaner elements with damaged pleats, gaskets or seals. Dirt entering the engine causes premature wear and damage to engine components. Air cleaner elements help to prevent airborne debris from entering the air inlet.

NOTICE

Never service the air cleaner element with the engine running since this will allow dirt to enter the engine.

Servicing the Air Cleaner Elements

Note: The engine air cleaner may not have been supplied by Perkins. Refer to the Original Equipment Manufacturer (OEM) information for further details on the engine air cleaner maintenance.

If the air cleaner element becomes plugged, the air can split the material of the air cleaner element. Unfiltered air will drastically accelerate internal engine wear.

- Check the precleaner (if equipped) and the dust bowl daily for accumulation of dirt and debris. Remove any dirt and debris, as needed.
- Operating in dirty conditions may require more frequent service of the air cleaner element.
- The air cleaner element should be replaced at least one time per year.

Replace the dirty air cleaner elements with clean air cleaner elements. Before installation, the new air cleaner elements should be thoroughly checked for tears and/or holes in the filter material. Inspect the gasket or the seal of the air cleaner element for damage. Maintain a supply of suitable air cleaner elements for replacement purposes.

Some application can have dual elements. The dual air cleaner contains a primary air cleaner element and a secondary air cleaner element. Both element must be replaced at the same time.

Do not replace the air cleaner filter elements in a dirty environment, as dirt can enter the air system when the elements are removed.

Air Cleaners type 1

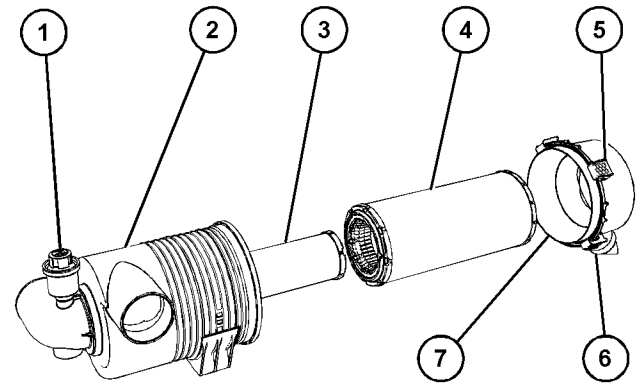

Illustration 97

g07537605

Typical example

- (1) Air Service Indicator
- (2) Air Cleaner Body
- (3) Secondary Air Filter Element
- (4) Primary Air Filter Element
- (5) Clips
- (6) Vacuum Valve
- (7) End Cover

1. Ensure that the outer body of the air cleaner to be serviced is clean and free from dirt.
2. Release clips (5) and remove end cover (7) from air cleaner body (2). If necessary, clean end cover and ensure that the valve (6) is clean and free from dirt. Check the valve (6) for wear or damage, replace if necessary.
3. Remove primary air filter element (4) and, remove the secondary air filter element (3). Discard all old air filter elements.
4. Install new secondary air filter element (3) and install new primary air filter element (4).
5. Install end cover (7) to air cleaner body (2) and secure end cover clips (5). If necessary, reset the air service indicator (1), refer to this Operation and Maintenance Manual, Engine Air Cleaner Service Indicator - Inspect for more information.

Air Cleaners type 2

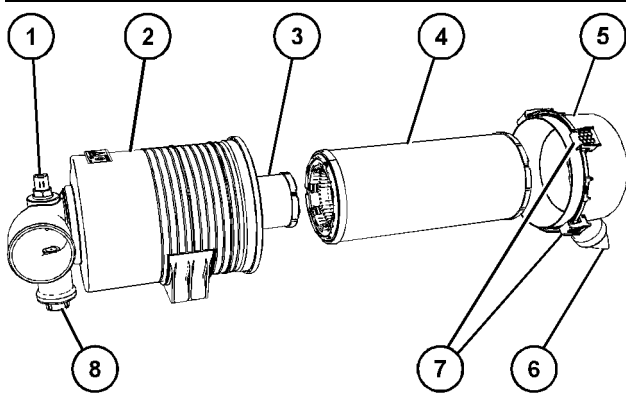

Illustration 98

g07531939

Typical example

- (1) Inlet Air temperature sensor
- (2) Air Cleaner Body
- (3) Secondary Air Filter Element
- (4) Primary Air Filter Element
- (5) End Cover
- (6) Vacuum Valve
- (7) Clips
- (8) Air Service Indicator

1. Ensure that the outer body of the air cleaner to be serviced is clean and free from dirt.
2. Release clips (7) and remove end cover (5) from air cleaner body (2). If necessary, clean end cover and ensure that the valve (6) is clean and free from dirt. Check the valve (6) for wear or damage, replace if necessary.
3. Remove primary air filter element (4) and, remove the secondary air filter element (3). Discard all old air filter elements.
4. Install new secondary air filter element (3) and install new primary air filter element (4).
5. Install end cover (5) to air cleaner body (2) and secure end cover clips (7). If necessary, reset the air service indicator (8), refer to this Operation and Maintenance Manual, Engine Air Cleaner Service Indicator - Inspect for more information.

i09119853

Engine Air Cleaner Service Indicator - Inspect

Some engines may be equipped with a different service indicator.

Some engines are equipped with a differential gauge for inlet air pressure. The differential gauge for inlet air pressure displays the difference in the pressure that is measured before the air cleaner element and the pressure that is measured after the air cleaner element. As the air cleaner element becomes dirty, the pressure differential rises. If your engine is equipped with a different type of service indicator, follow the OEM recommendations to service the air cleaner service indicator.

Type 1 Service Indicator

The service indicator may be mounted on the air cleaner element or in a remote location.

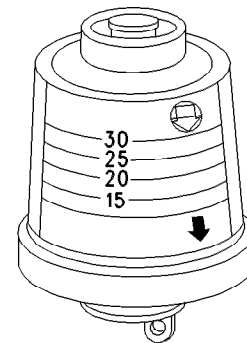

Illustration 99

g00103777

Typical example of type 1 service indicator

Observe the service indicator. The air cleaner element should be cleaned or the air cleaner element should be replaced when one of the following conditions occurs:

- The yellow diaphragm enters the red zone.
- The red piston locks in the visible position.

Type 2 Service Indicator

The service indicator is installed on the air cleaner element. The service indicator is to be tightened by hand, ensuring the o ring seal is in place.

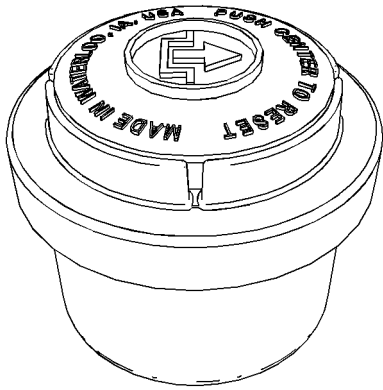

Illustration 100

g07079288

Typical example of type 2 service indicator

Observe the service indicator. The air cleaner element should be cleaned or the air cleaner element should be replaced when one of the following conditions occurs:

- The yellow diaphragm enters the red zone.
- The red piston locks in the visible position.

Test the Service Indicator

Service indicators are important instruments.

- Check for ease of resetting. The service indicator should reset in fewer than three pushes.
- Check the movement of the yellow core when the engine is accelerated to the engine rated speed. The yellow core should latch at the greatest vacuum that is attained.

If the service indicator does not reset easily, or if the yellow core does not latch at the greatest vacuum, the service indicator should be replaced. If the new service indicator will not reset, the hole for the service indicator may be restricted.

The service indicator may need to be replaced frequently in environments that are severely dusty.

i07819526

Engine Air Precleaner - Check/Clean

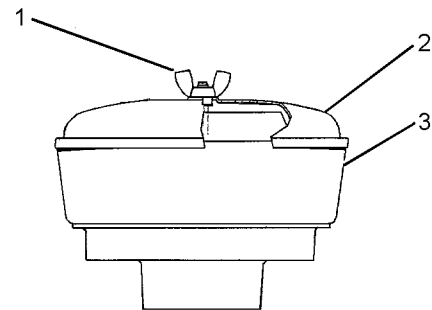

Illustration 101

g01453058

Typical engine air pre-cleaner

- (1) Wing nut
- (2) Cover
- (3) Body

Remove wing nut (1) and cover (2). Check for an accumulation of dirt and debris in body (3). Clean the body, if necessary.

After cleaning the pre-cleaner, install cover (2) and wing nut (1).

Note: When the engine is operated in dusty conditions, more frequent cleaning is required.

Do not tap or strike the air cleaner element.

i07819538

Engine Mounts - Inspect

Note: The engine mounts may not have been supplied by Perkins. Refer to the Original Equipment Manufacturer (OEM) information for further details on the engine mounts and the correct bolt torque.

Inspect the engine mounts for deterioration and for correct bolt torque. Excessive engine vibration can be caused by the following conditions:

- Incorrect mounting of the engine
- Deterioration of the engine mounts
- Loose engine mounts

Any engine mount that shows deterioration should be replaced. Refer to the OEM information for the recommended torques.

When the engine mounts are supplied by Perkins the maintenance procedure will be supplied in the Disassembly and Assembly manual for your engine.

i06862328

Engine Oil Level - Check

WARNING

Hot oil and hot components can cause personal injury. Do not allow hot oil or hot components to contact the skin.

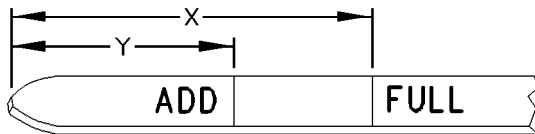

Illustration 102

g00110310

(Y) "ADD" mark. (X) "FULL" mark.

NOTICE

Perform this maintenance with the engine stopped.

1. Maintain the oil level between "ADD" mark (Y) and "FULL" mark (X) on oil level gauge (1). Do not fill the crankcase above "FULL" mark (X).

NOTICE

Operating your engine when the oil level is above the "FULL" mark could cause your crankshaft to dip into the oil. The air bubbles created from the crankshaft dipping into the oil reduces the oil's lubricating characteristics and could result in the loss of power or engine failure.

2. Remove the oil filler cap and add oil, if necessary. Clean the oil filler cap. Install the oil filler cap.

i09650255

Engine Oil and Filter - Change

WARNING

Hot oil and hot components can cause personal injury. Do not allow hot oil or hot components to contact the skin.

NOTICE

Care must be taken to ensure that fluids are contained during performance of inspection, maintenance, testing, adjusting and repair of the product. Be prepared to collect the fluid with suitable containers before opening any compartment or disassembling any component containing fluids.

Dispose of all fluids according to local regulations and mandates.

NOTICE

Keep all parts clean from contaminants.

Contaminants may cause rapid wear and shortened component life.

Do not drain the engine lubricating oil when the engine is cold. As the engine lubricating oil cools, suspended waste particles settle on the bottom of the oil pan. The waste particles are not removed with draining cold oil. This draining method allows the waste particles that are suspended in the oil to be drained properly.

Failure to follow this recommended procedure will cause the waste particles to be recirculated through the engine lubrication system with the new oil.

Oil analysis

Some engines may be equipped with an oil sampling valve. If oil analysis is required, the oil sampling valve is used to obtain samples of the engine oil. The oil analysis will complement the preventive maintenance program.

Note: Ensure that there is sufficient quantity of oil in the engine before taking a sample of oil with the engine in operation. The engine oil capacity must not go below the minimum quantity specified on the oil level gauge. Refer to this Operation and Maintenance Manual, "Engine Oil Level - Check" for the correct procedure.

The oil analysis is a diagnostic tool that is used to determine oil performance and component wear rates. Contamination can be identified and measured by using oil analysis. The oil analysis includes the following tests:

- The Wear Rate Analysis monitors the wear of the engines metals. The amount of wear metal and type of wear metal that is in the oil is analyzed. The increase in the rate of engine wear metal in the oil is as important as the quantity of engine wear metal in the oil.
- Tests are conducted to detect contamination of the oil by water, glycol, or fuel.
- The Oil Condition Analysis determines the loss of the oils lubricating properties. An infrared analysis is used to compare the properties of new oil to the properties of the used oil sample. This analysis allows technicians to determine the amount of deterioration of the oil during use. This analysis also allows technicians to verify the performance of the oil according to the specification during the entire oil change interval.

Drain the Engine Lubricating Oil From a Standard Oil Pan

Note: Ensure that the container that will be used is large enough to collect the waste oil.

After the engine has been run at the normal operating temperature, stop the engine. Use the following method to drain the engine oil pan:

This oil pan is equipped with 2 drain plugs for ease of access. Any one of the 2 drain plugs can be used to drain the oil.

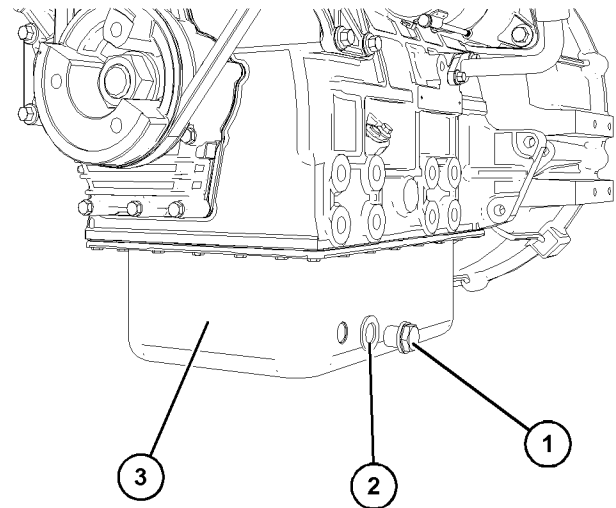

Illustration 103

g06545602

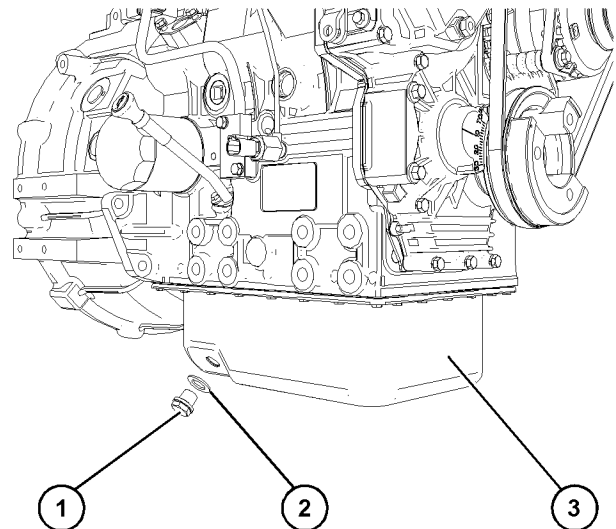

Illustration 104

g06545595

Typical examples of a standard oil pan.

1. Place container below oil drain plug (1). Remove oil drain plug (1) and allow the oil to drain into the container for storage or disposal.
2. Remove drain plug seal (2) from the drain plug. Discard the drain plug seal.
3. Clean oil drain plug (1) and install new drain plug seal (2). Install oil drain plug (1) into oil pan (3).
4. Tighten oil drain plug (1) as follows:

- For M12 drain plug tighten to a torque of $22.5 \pm 2.5 \text{ N}\cdot\text{m}$ ($199 \pm 22 \text{ lb in}$)
- For M16 drain plug tighten to a torque of $35 \pm 5 \text{ N}\cdot\text{m}$ ($310 \pm 44 \text{ lb in}$)

Note: A drain valve may be installed. Tighten the drain valve to a torque of $34 \text{ N}\cdot\text{m}$ (301 lb in).

5. Remove container below oil drain plug (1) and discard waste oil in accordance with local regulations.

Draining the Engine Lubricating Oil from an Engine Equipped with a Balancer

Note: Ensure that the container that will be used is large enough to collect the waste oil.

Note: Both sides of the oil pan are to be drained on engines equipped with a balancer.

After the engine has been run at the normal operating temperature, stop the engine. Use the following method to drain the engine oil pan:

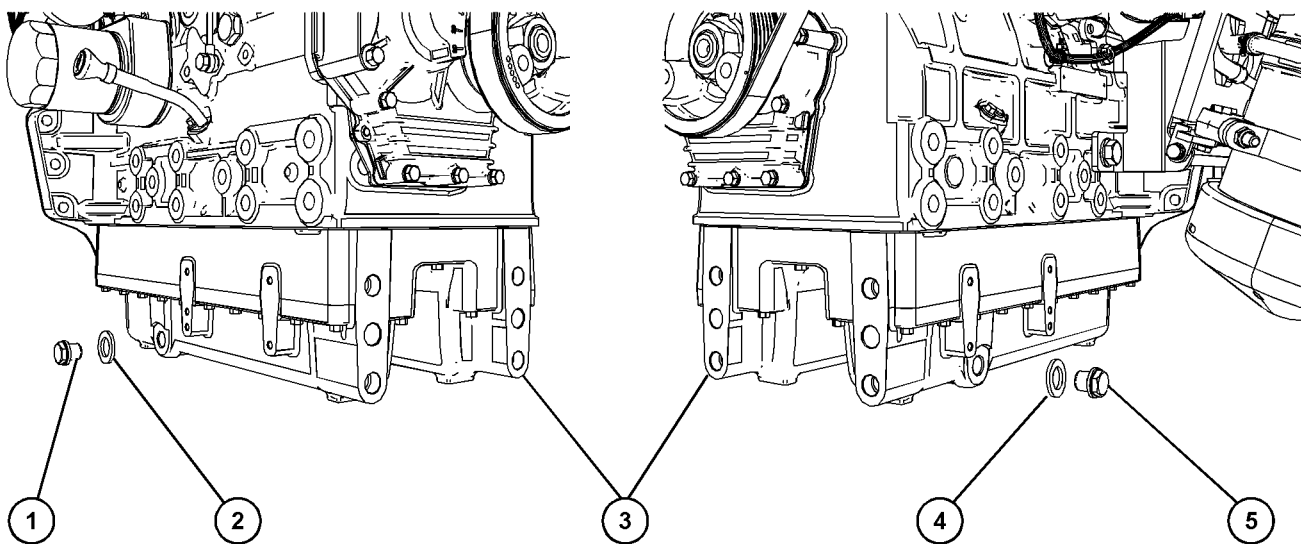

Illustration 105

g06545606

Typical example of an oil pan for engines equipped with a balancer

1. Place container below oil drain plug (1) and oil drain plug (5).
2. Remove oil drain plug (1) and oil drain plug (5) from engine oil pan (3) and allow the oil to drain into the container for storage or disposal.
3. Remove drain plug seal (2) and drain plug seal (4). Discard the seals.
4. Clean the oil drain plugs and install new drain plug seal (2) and new drain plug seal (4). Install oil drain plug (1) and oil drain plug (5) into oil pan (3).

5. Tighten oil drain plug (1) and oil drain plug (5) to a torque of 34 N·m (301 lb in). Remove container below oil drain plug (1) and discard waste oil in accordance with local regulations.

Replace the Oil Filter

NOTICE

Perkins oil filters are built to Perkins specifications. Use of an oil filter not recommended by Perkins could result in severe engine damage to the engine bearings, crankshaft, etc., as a result of the larger waste particles from unfiltered oil entering the engine lubricating system. Only use oil filters recommended by Perkins.

1. Remove the oil filter with a suitable tool.
2. Clean the sealing mating surface on the engine (1).

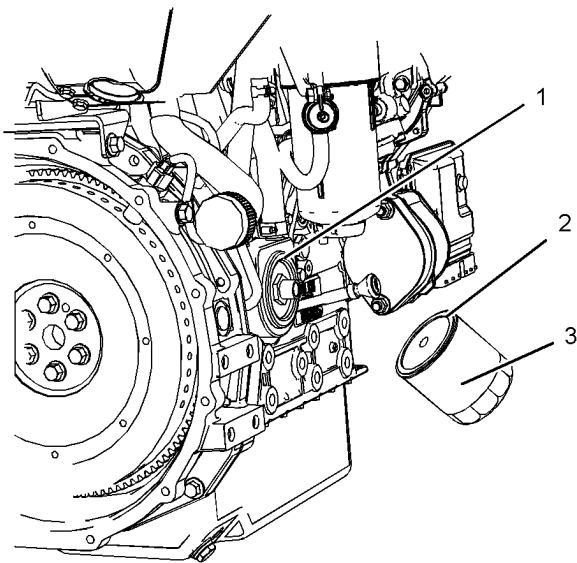

Illustration 106

g03890458

3. Apply clean engine oil to the new oil filter seal (2).

NOTICE

Do not fill the oil filters with oil before installing them. This oil would not be filtered and could be contaminated. Contaminated oil can cause accelerated wear to engine components or engine damage.

4. Install the oil filter (3). Tighten the oil filter by hand. Do not overtighten the oil filter.

Fill the Engine Crankcase

Refer to the Operation and Maintenance Manual, Fluid Recommendations for more information on lubricant specifications. Fill the crankcase with the correct amount of oil. Refer to the Operation and Maintenance Manual, Refill Capacities for more information on capacities.

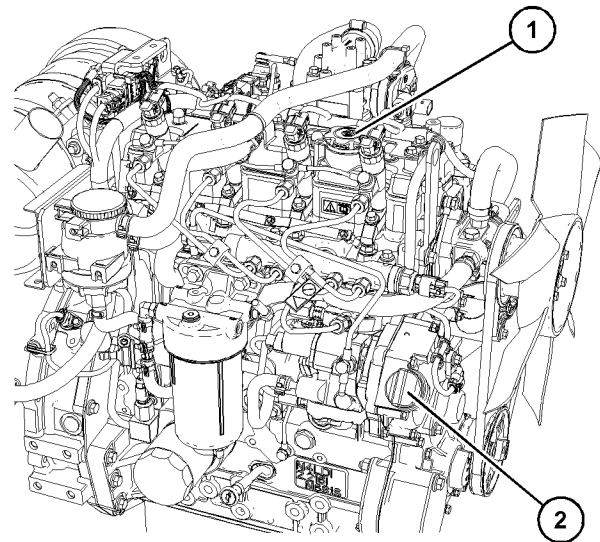

Illustration 107

g06546945

Typical example

- (1) Upper oil fill cap
- (2) Lower oil filler cap

1. Remove the oil filler cap.

NOTICE

If equipped with an auxiliary oil filter system or a remote oil filter system, follow the OEM or filter manufacturer's recommendations. Under filling or overfilling the crankcase with oil can cause engine damage.

2. Refill with the correct specification and correct amount of lubricating oil.

NOTICE

To prevent crankshaft bearing damage, crank the engine with the fuel OFF. This will fill the oil filters before starting the engine. Do not crank the engine for more than 30 seconds.

Maintenance Section
Engine Valve Lash - Check

3. Start the engine and run the engine at "LOW IDLE" for 2 minutes. Perform this procedure to ensure that the lubrication system has oil and that the oil filters are filled. Inspect the oil filter for oil leaks.
4. Stop the engine and allow the oil to drain back to the sump for a minimum of 10 minutes.

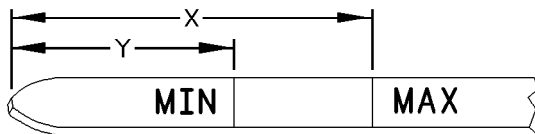

Illustration 108

g00986928

Typical example

5. Remove the engine oil level gauge to check the oil level. Maintain the oil level between "MIN" and "MAX" marks on the engine oil level gauge.

i06299296

Engine Valve Lash - Check

WARNING

Ensure that the engine cannot be started while this maintenance is being performed. To help prevent possible injury, do not use the starting motor to turn the flywheel.

Hot engine components can cause burns. Allow additional time for the engine to cool before measuring/adjusting valve lash clearance.

NOTICE

Only qualified service personnel should perform this maintenance.

Operation of the engines with incorrect valve lash can reduce engine efficiency, and also reduce engine component life.

This maintenance is recommended as part of a lubrication and preventive maintenance schedule in order to help provide maximum engine life. The maintenance for the valve lash is important in order to keep the engine compliant.

Ensure that the engine is stopped before measuring the valve lash. The engine valve lash can be inspected and adjusted when the engine is cold.

- Inlet valve _____ 0.20 mm (0.8 inch)
- Exhaust valve _____ 0.20 mm (0.8 inch)

Refer to Systems Operation, Testing and Adjusting, "Engine Valve Lash - Inspect/Adjust" for the correct sequence of adjustment.

i09650287

Fan Clearance - Check

Industrial Open Power Unit (IOPU) Radiators

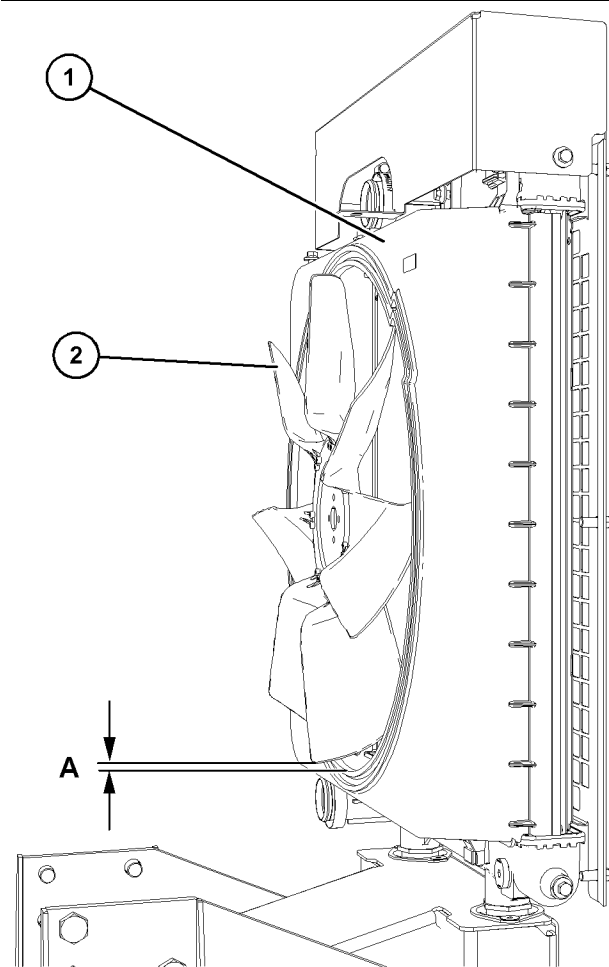

Illustration 109

g07532890

Typical example

Ensure that the engine is stopped. Ensure that the battery disconnect switch is in the OFF position. Ensure that the cooling system is full.

The clearance between the cover (1) and the fan (2) will require checking. The gap between the edge of the cover and the tip of the fan blade (A) must be checked in four equally spaced positions.

The clearance is to be:

- For the three cylinder engine, (A) equals 8 mm (0.315 inch)
- For the four cylinder engine, (A) equals 8.5 mm (0.335 inch)

Factory Installed Radiators

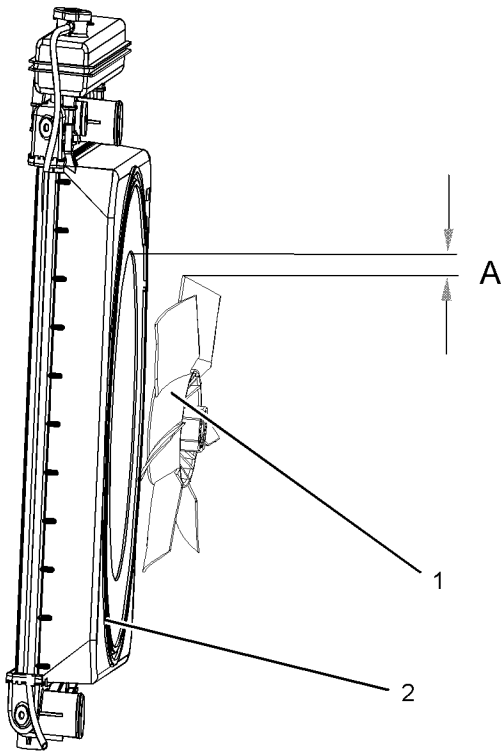

Illustration 110

g03309719

Typical example

Ensure that the engine is stopped. Ensure that the battery disconnect switch is in the OFF position. Ensure that the cooling system is full.

The clearance between the cover (2) and the fan (1) will require checking. The gap between the edge of the cover and the tip of the fan blade (A) must be checked in four equally spaced positions.

Note: The cover is not adjustable.

Three Cylinder

- (A) equals 5 mm (0.19685 inch) for the three cylinder engine

Four Cylinder Turbocharged

- (A) equals 10 mm (0.39370 inch) for the turbocharged engine.

Four Cylinder Turbocharged Aftercooled

- (A) equals 8 mm (0.31496 inch) for the turbocharged aftercooled engine.

i08197312

Fuel System - Prime

Note: Refer to Systems Operation, Testing, and Adjusting, "Cleanliness of Fuel System Components" for detailed information on the standards of cleanliness that must be observed during ALL work on the fuel system.

Ensure that all adjustments and repairs are performed by authorized personnel that have had the correct training.

NOTICE

Do not crank the engine continuously for more than 30 seconds. Allow the starting motor to cool for two minutes before cranking the engine again.

If air enters the fuel system, the air must be purged from the fuel system before the engine can be started. Air can enter the fuel system when the following events occur:

- The fuel tank is empty or the fuel tank has been partially drained.
- The low-pressure fuel lines are disconnected.
- A leak exists in the low-pressure fuel system.
- The fuel filter has been replaced.

Use the following procedures to remove air from the fuel system:

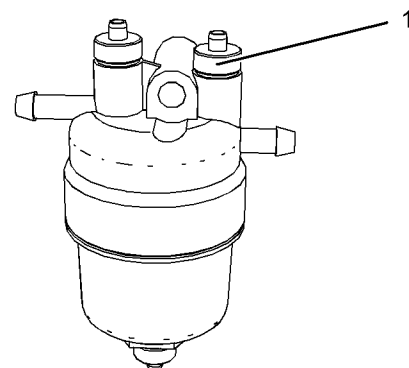

Illustration 111

g03891128

Typical example

Maintenance Section
Fuel System - Prime

1. Ensure that the fuel tank is full and any fuel valve (if equipped) is in the "ON" position.
 2. If the application has a gravity feed fuel system, then loosen vent screw (1) and allow fuel to flow. When fuel free from air comes from the vent screw, tighten the vent screw (1) by hand . If the fuel system is not a gravity feed fuel system, then go to Step 3.
-

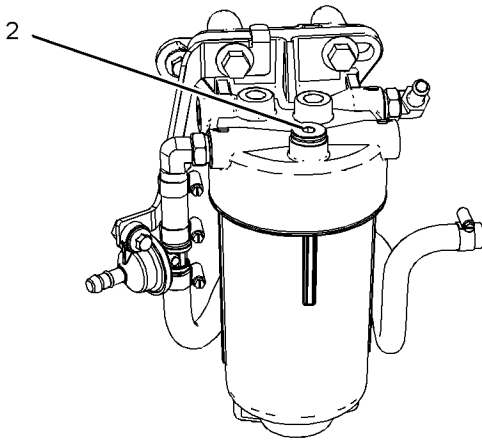

Illustration 112

g03891159

Typical example

3. Loosen the vent screw (2) on the secondary fuel filter. Turn the keyswitch to the "RUN" position.
4. The keyswitch will allow the electric priming pump to operate. When fuel free from air comes from the vent screw (2), tighten the vent screw to a torque of 24 N·m (212. lb in). Then, operate the electric priming pump for 2 minutes.
5. Turn the keyswitch to the "OFF" position. The fuel system will now be primed and the engine should be able to start.
6. Operate the engine starter and crank the engine. After the engine has started, operate the engine at low idle for a minimum of 5 minutes. For constant speed engines do not apply load for 5 minutes.

Note: Operating the engine for this period will help ensure that the fuel system is free of air. **DO NOT loosen the high-pressure fuel lines to purge air from the fuel system. This procedure is not required.**

7. Ensure that the fuel system is free from leaks.

After the engine has stopped, you must wait for 10 minutes to allow the fuel pressure to be purged from the high-pressure fuel lines before any service or repair is performed on the engine fuel lines. The 10 minute wait will also allow static charge to dissipate from the low-pressure fuel system. If necessary, perform minor adjustments. Repair any leaks from the low-pressure fuel system and from the cooling, lubrication, or air systems. Replace any high-pressure fuel line that has leaked. Refer to Disassembly and Assembly Manual, "Fuel Injection Lines - Install".

If you inspect the engine in operation, always use the proper inspection procedure to avoid a fluid penetration hazard. Refer to Operation and Maintenance Manual, "General hazard Information".

If the engine will not start, refer to Troubleshooting, "Engine Cranks but will not Start".

Hand Priming (If Equipped)

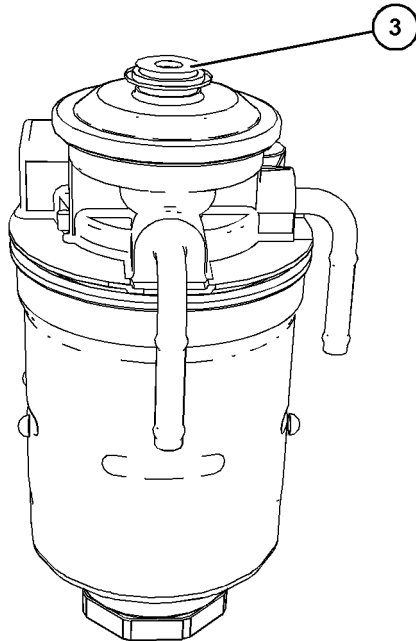

Illustration 113

g06583662

Operate the hand priming pump (3) to prime the low-pressure fuel lines.

i06299386

Fuel System Primary Filter (Water Separator) Element - Replace

WARNING

Fuel leaked or spilled onto hot surfaces or electrical components can cause a fire. To help prevent possible injury, turn the start switch off when changing fuel filters or water separator elements. Clean up fuel spills immediately.

Note: Refer to Systems Operation, Testing, and Adjusting, “Cleanliness of Fuel System Components” for detailed information on the standards of cleanliness that must be observed during ALL work on the fuel system.

NOTICE

Ensure that the engine is stopped before any servicing or repair is performed.

Remove the Element

1. Turn the fuel supply valve (if equipped) to the OFF position before performing this maintenance.
2. Place a suitable container under the water separator in order to catch any fuel that might spill. Clean up any spilled fuel. Clean the outside body of the filter assembly.

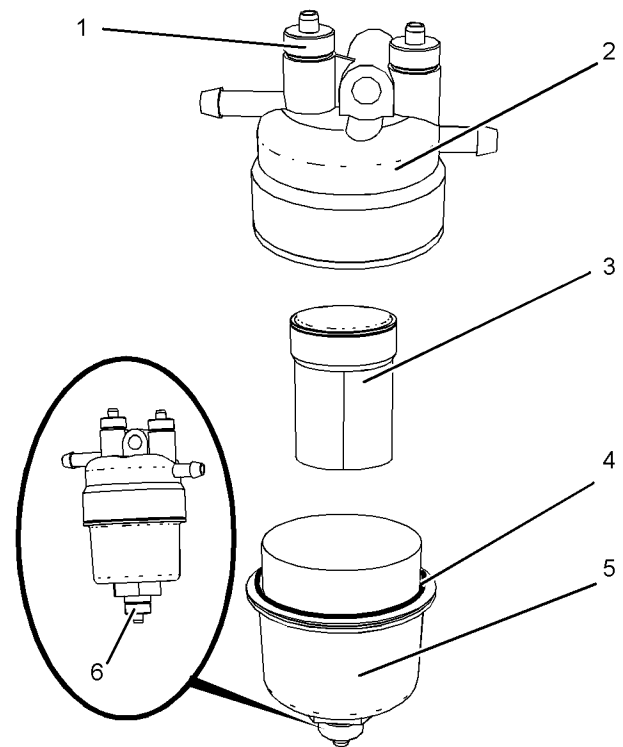

Illustration 114

g03891253

3. Open drain valve (6) and open vent screw (1) and drain the filter. Close drain screw and close vent screw. Use only hand pressure in order to tighten the drain screw and the vent screw.
4. Remove filter bowl (5) from filter (2) and remove filter element (3) from filter (2). Discard filter element (3).
5. Remove O ring seal (4) and discard O ring seal (4).
6. Ensure that all components are clean and dry.
7. Install new O ring seal (4) and install new filter element (3).

8. Install filter bowl (5) to filter (2) and tighten the filter bowl to a torque of 10 N·m (88 lb in).
9. If necessary, open the fuel supply valve. Remove the container and dispose of the fuel in a safe place.
10. The secondary filter element must be replaced at the same time as the primary filter element. Refer to the Operation and Maintenance Manual, "Fuel System Filter - Replace".

i07820738

Fuel System Primary Filter (Water Separator) Element - Replace

(Primary Fuel Filter With Water In Fuel (WIF) Sensor)

WARNING

Fuel leaked or spilled onto hot surfaces or electrical components can cause a fire. To help prevent possible injury, turn the start switch off when changing fuel filters or water separator elements. Clean up fuel spills immediately.

Note: Refer to Systems Operation, Testing, and Adjusting, "Cleanliness of Fuel System Components" for detailed information on the standards of cleanliness that must be observed during ALL work on the fuel system.

NOTICE

Ensure that the engine is stopped before any servicing or repair is performed.

NOTICE

Care must be taken to ensure that fluids are contained during performance of inspection, maintenance, testing, adjusting, and repair of the product. Be prepared to collect the fluid with suitable containers before opening any compartment or disassembling any component containing fluids.

Dispose of all fluids according to local regulations and mandates.

Remove the Element

1. Turn the fuel supply valve (if equipped) to the OFF position before performing this maintenance.

2. Clean the outside body of the fuel filter assembly.
3. Place a suitable container under the water separator to catch any fuel that might spill. Clean up any spilled fuel.

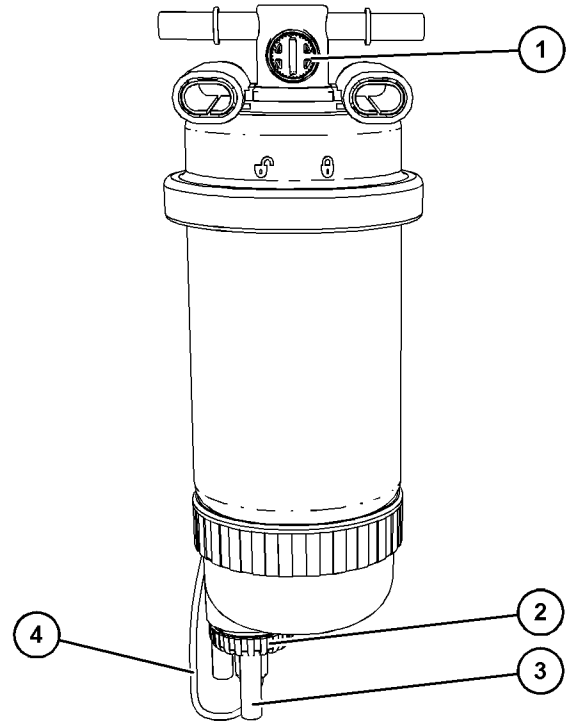

Illustration 115

g06446752

Typical example

4. Disconnect harness assembly (4) from the fuel filter assembly and position away from the fuel filter assembly to prevent the connection becoming wet during the filter change.
 5. Install a suitable tube onto drain valve outlet (3). Open drain valve (2) and capture all fluids in the suitable container.
 6. Loosen the vent screw (1).
 7. Allow the fuel to drain into the container. If the fuel will not drain, loosen the vent screw on the secondary fuel filter.
- Note:** In some applications, the vent screw on the secondary fuel filter will need to be open to drain the primary fuel filter.
8. Tighten the vent screw (1).
 9. If necessary, tighten the vent screw on the secondary fuel filter.
 10. Remove the tube from the drain valve outlet.

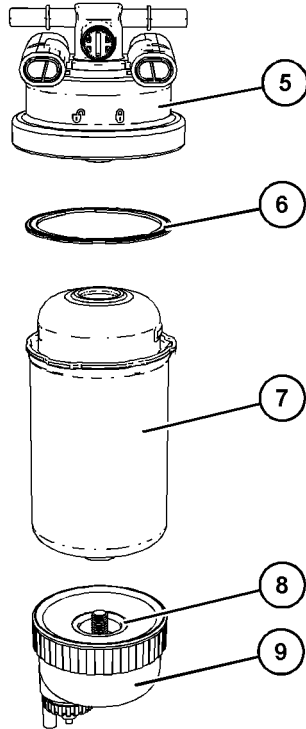

Illustration 116

g06446785

Typical example

11. Rotate filter bowl (9) counterclockwise and remove the filter bowl from the fuel filter assembly.
12. Rotate the filter element (7) counterclockwise and remove the filter element from fuel filter head (5).
13. Remove seal (6).
14. Remove O ring seal (8)

15. Clean filter bowl (9).

Install the New Filter Element

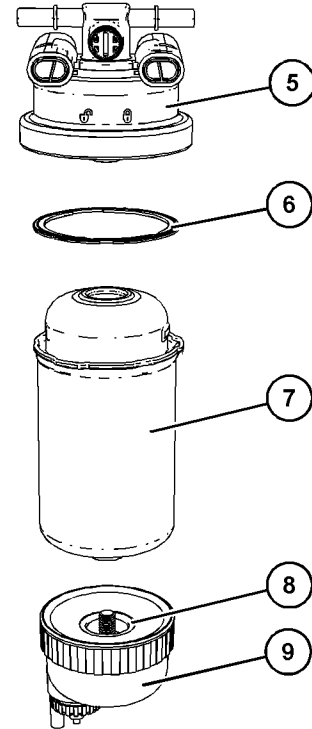

Illustration 117

g06446785

Typical example

1. Install new seal (6) to fuel filter (7).
2. Install fuel filter (7) to fuel filter head (5). Tighten the fuel filter securely by hand.
3. Install new O ring seal (8) to fuel filter bowl (9). Do NOT fill the bowl with fuel before the assembly is installed.
4. Install fuel filter bowl (9) to fuel filter (7). Tighten the fuel filter bowl securely by hand.

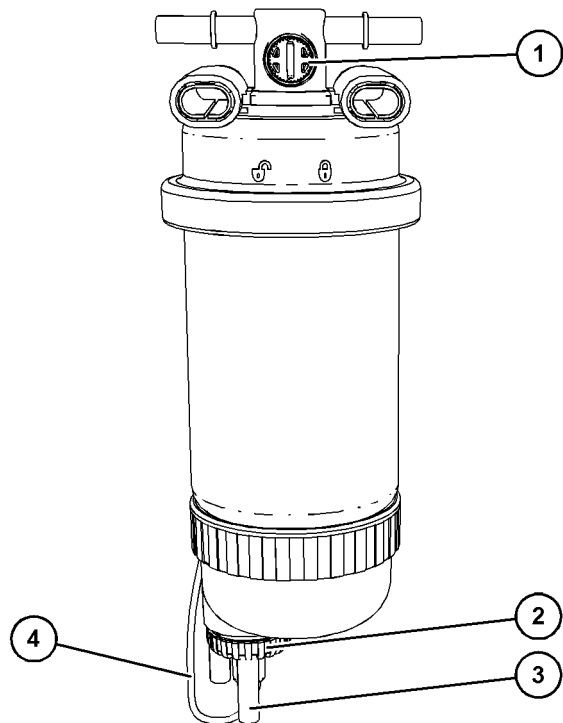

Illustration 118

g06446752

Typical example

5. Tighten drain valve (2) securely and ensure that drain valve outlet (3) is dry.
6. Remove the container and dispose of all fluids according to local regulations and mandates.
7. Connect harness assembly (4) to the fuel filter assembly.
8. The secondary fuel filter element must be replaced at the same time as the primary fuel filter element. Refer to this Operation and Maintenance Manual, "Fuel System Secondary Filter - Replace" for more information.

9. Turn the fuel supply valve (if equipped) to the ON position after performing this maintenance.

i07820721

Fuel System Primary Filter/ Water Separator - Drain

(Primary Fuel Filter With Water In Fuel (WIF) Sensor)

⚠ WARNING

Fuel leaked or spilled onto hot surfaces or electrical components can cause a fire. To help prevent possible injury, turn the start switch off when changing fuel filters or water separator elements. Clean up fuel spills immediately.

Note: Refer to Systems Operation, Testing, and Adjusting, "Cleanliness of Fuel System Components" for detailed information on the standards of cleanliness that must be observed during ALL work on the fuel system.

NOTICE

Ensure that the engine is stopped before any servicing or repair is performed.

NOTICE

The water separator is not a filter. The water separator separates water from the fuel. The engine should never be allowed to run with the water separator more than half full. Engine damage may result.

NOTICE

Care must be taken to ensure that fluids are contained during performance of inspection, maintenance, testing, adjusting, and repair of the product. Be prepared to collect the fluid with suitable containers before opening any compartment or disassembling any component containing fluids.

Dispose of all fluids according to local regulations and mandates.

i07905847

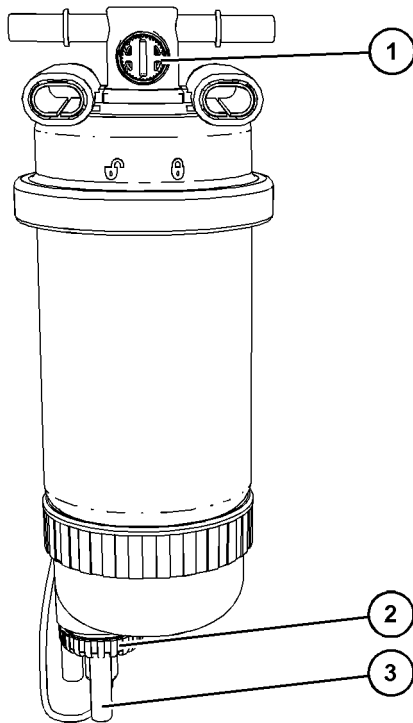

Illustration 119

g06446731

Primary fuel filter with Water In Fuel (WIF) sensor.

1. Attach a suitable length of hose to outlet (3) to capture the fluid that is being drained from the primary fuel filter assembly into a suitable container.
2. Open drain valve (2). Capture the draining fluid into the suitable container.
3. If necessary, open vent screw (1) to allow the fluid to be drained.
4. Close drain valve (2) hand tight.
5. If necessary, close vent screw (1) hand tight.
6. Dispose of the drained fluid correctly.

Also, drain water from the secondary fuel filter. Refer to this "Operation and Maintenance Manual" Fuel System Secondary Filter/Water Separator - Drain for more information.

NOTICE

The water separator is under suction during normal engine operation. Ensure that the drain valve and vent screw is tightened securely to help prevent air from entering the fuel system.

Fuel System Primary Filter/ Water Separator - Drain

! WARNING

Fuel leaked or spilled onto hot surfaces or electrical components can cause a fire. To help prevent possible injury, turn the start switch off when changing fuel filters or water separator elements. Clean up fuel spills immediately.

NOTICE

The water separator is not a filter. The water separator separates water from the fuel. The engine should never be allowed to run with the water separator more than half full. Engine damage may result.

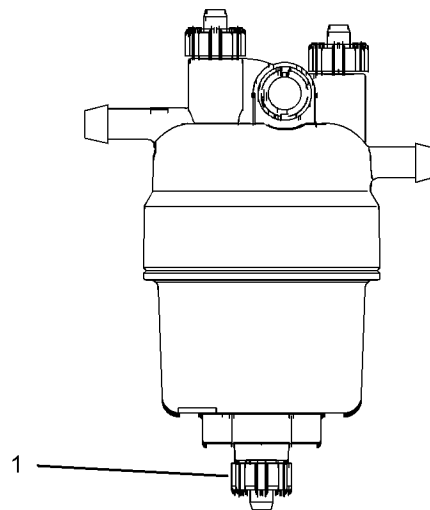

Illustration 120

g01316965

Typical example

1. Open drain (1). Catch the draining fluid in a suitable container. Dispose of the drained fluid correctly.
2. Close drain (1) use hand pressure only.

Also, drain water from the secondary fuel filter. Refer to the "Operation and Maintenance Manual" Fuel System Secondary Filter/Water Separator-Drain for more information.

NOTICE

The water separator is under suction during normal engine operation. Ensure that the drain valve is tightened securely to help prevent air from entering the fuel system.

i08106019

Fuel System Secondary Filter - Replace

⚠ WARNING

Fuel leaked or spilled onto hot surfaces or electrical components can cause a fire. To help prevent possible injury, turn the start switch off when changing fuel filters or water separator elements. Clean up fuel spills immediately.

NOTICE

Ensure that the engine is stopped before any servicing or repair is performed.

Refer to Systems Operation, Testing, and Adjusting, "Cleanliness of Fuel System Components" for detailed information on the standards of cleanliness that must be observed during ALL work on the fuel system.

Remove the Filter Element

1. Turn the fuel supply valve (if equipped) to the OFF position before performing this maintenance.
2. Place a suitable container under the fuel filter to catch any fuel that might spill. Clean up any spilled fuel. Clean the outside body of the filter assembly.

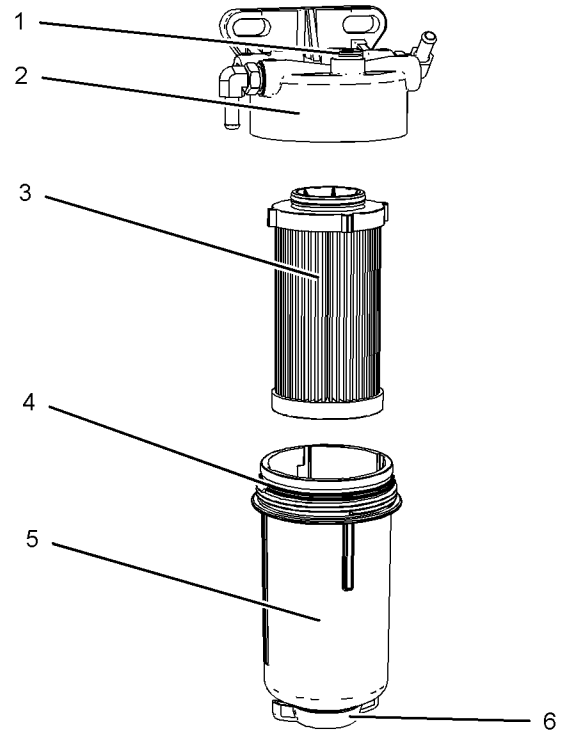

Illustration 121

g03891817

3. Open the drain valve (6) and if necessary, open vent screw (1). Allow the fuel to drain from the filter. Tighten vent screw (1) securely and close drain valve (6).
4. Use a suitable strap wrench remove the filter bowl (5) from filter base (2).
5. Remove the filter element (3) and discard the element. Remove the O ring seal (4) from filter bowl (5). Discard the old O ring seal.
6. Ensure the filter bowl (5) is clean and free from dirt.

Remove the Canister Fuel Filter

1. Turn the fuel supply valve (if equipped) to the OFF position before performing this maintenance.
2. Place a suitable container under the fuel filter to catch any fuel that might spill. Clean up any spilled fuel. Clean the outside body of the filter assembly.

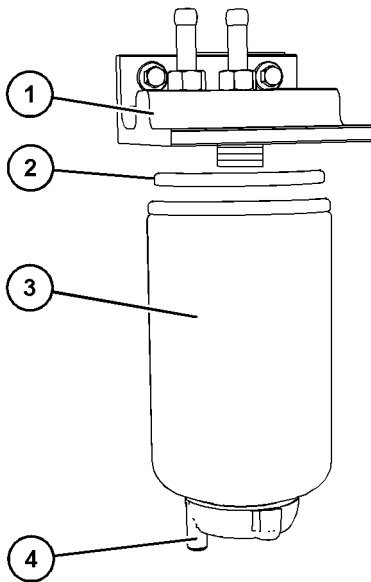

Illustration 122

g06545420

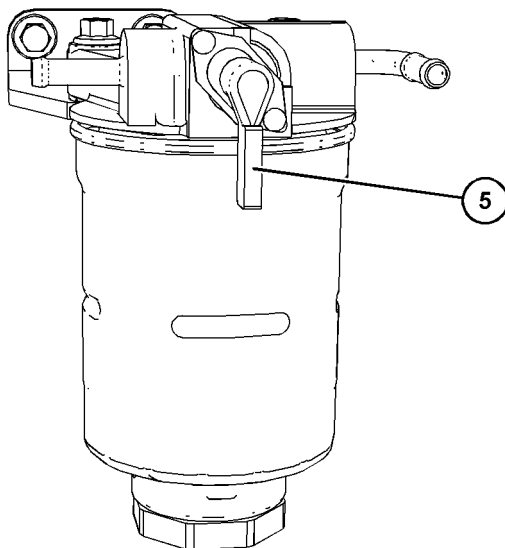

Illustration 123

g06545948

3. Turn the fuel filter head shut-off valve (5) (if equipped) to the OFF position.
4. Open the drain valve (4) and allow the fuel to drain from the fuel filter.
5. Use a suitable strap wrench to remove fuel filter (3) from fuel filter base (1).
6. Remove fuel filter (3) and discard the fuel filter. Ensure that O-ring seal (2) is removed from fuel filter base (1). Discard the O-ring seal.

Install the Filter Element

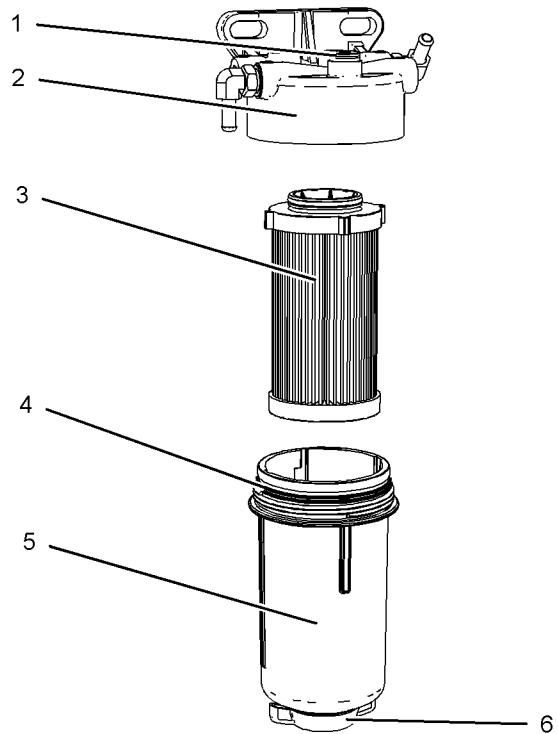

Illustration 124

g03891817

1. Install filter element (3) into filter base (2).
2. Install a new O ring seal (4) to filter bowl (5) and install filter bowl (5) to filter base (2). Do not use a tool to install the filter assembly. Use hand pressure only to tighten filter bowl.
3. Turn the fuel supply valve (if equipped) to the ON position
4. The primary fuel filter the secondary fuel filter must be replaced at the same time. Prime the fuel system, refer to this Operation and Maintenance Manual, "Fuel System - Prime".

Install the Canister Fuel Filter

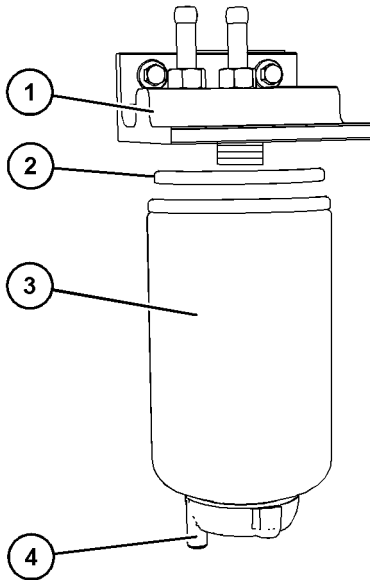

Illustration 125

g06545420

1. Ensure that O-ring seal (2) is in position on fuel filter (3). Lubricate the O-ring seal with clean diesel.
2. Install fuel filter (3) to fuel filter base (1) and tighten the fuel filter hand tight.

Note: Do not use a tool to tighten the fuel filter.

3. Close drain valve (4).
4. Turn the fuel supply valve (if equipped) to the ON position
5. The primary fuel filter the secondary fuel filter must be replaced at the same time. Prime the fuel system, refer to this Operation and Maintenance Manual, "Fuel System - Prime".

i06541262

Fuel System Secondary Filter/ Water Separator - Drain

WARNING

Fuel leaked or spilled onto hot surfaces or electrical components can cause a fire. To help prevent possible injury, turn the start switch off when changing fuel filters or water separator elements. Clean up fuel spills immediately.

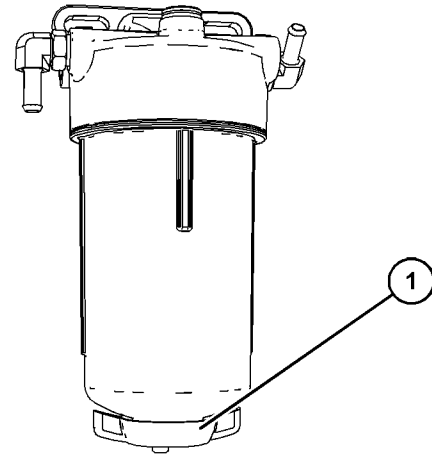

Illustration 126

g06014499

Typical example

1. Place a suitable container below filter. Open drain valve (1) and allow fluid to drain.
2. When necessary, close drain valve (1) with hand pressure only.

The procedure must be performed with primary fuel filter drain. Refer to this Operation and Maintenance Manual, Fuel System Primary Filter/Water Separator - Drain for more information.

i02348492

Fuel Tank Water and Sediment - Drain

NOTICE

Care must be taken to ensure that fluids are contained during performance of inspection, maintenance, testing, adjusting and repair of the product. Be prepared to collect the fluid with suitable containers before opening any compartment or disassembling any component containing fluids.

Dispose of all fluids according to local regulations and mandates.

Fuel Tank

Fuel quality is critical to the performance and to the service life of the engine. Water in the fuel can cause excessive wear to the fuel system.

Water can be introduced into the fuel tank when the fuel tank is being filled.

Condensation occurs during the heating and cooling of fuel. The condensation occurs as the fuel passes through the fuel system and the fuel returns to the fuel tank. This causes water to accumulate in fuel tanks. Draining the fuel tank regularly and obtaining fuel from reliable sources can help to eliminate water in the fuel.

Drain the Water and the Sediment

Fuel tanks should contain some provision for draining water and draining sediment from the bottom of the fuel tanks.

Open the drain valve on the bottom of the fuel tank in order to drain the water and the sediment. Close the drain valve.

Check the fuel daily. Allow five minutes after the fuel tank has been filled before draining water and sediment from the fuel tank.

Fill the fuel tank after operating the engine in order to drive out moist air. This will help prevent condensation. Do not fill the tank to the top. The fuel expands as the fuel gets warm. The tank may overflow.

Some fuel tanks use supply pipes that allow water and sediment to settle below the end of the fuel supply pipe. Some fuel tanks use supply lines that take fuel directly from the bottom of the tank. If the engine is equipped with this system, regular maintenance of the fuel system filter is important.

Fuel Storage Tanks

Drain the water and the sediment from the fuel storage tank at the following intervals:

- Weekly
- Service intervals
- Refill of the tank

This will help prevent water or sediment from being pumped from the storage tank into the engine fuel tank.

If a bulk storage tank has been refilled or moved recently, allow adequate time for the sediment to settle before filling the engine fuel tank. Internal baffles in the bulk storage tank will also help trap sediment. Filtering fuel that is pumped from the storage tank helps to ensure the quality of the fuel. When possible, water separators should be used.

i07819616

Hoses and Clamps - Inspect/Replace

WARNING

Contact with high pressure fuel may cause fluid penetration and burn hazards. High pressure fuel spray may cause a fire hazard. Failure to follow these inspection, maintenance and service instructions may cause personal injury or death.

If you inspect the engine in operation, always use the proper inspection procedure to avoid a fluid penetration hazard. Refer to Operation and Maintenance Manual, "General hazard Information" and Operation and Maintenance Manual, "High Pressure Fuel Lines" for the correct procedures.

Inspect all hoses for leaks that are caused by the following conditions:

- Cracking
- Softness
- Loose clamps

Replace hoses that are cracked or soft. Tighten any loose clamps.

Check for the following conditions:

- End fittings that are damaged or leaking
- Outer covering that is chafed or cut
- Exposed wire that is used for reinforcement
- Outer covering that is ballooning locally
- Flexible part of the hose that is kinked or crushed
- Armoring that is embedded in the outer covering

A constant torque hose clamp can be used in place of any standard hose clamp. Ensure that the constant torque hose clamp is the same size as the standard clamp.

Due to extreme temperature changes, the hose will harden. Hardening of the hoses will cause hose clamps to loosen. This can result in leaks. A constant torque hose clamp will help to prevent loose hose clamps.

Each installation application can be different. The differences depend on the following factors:

- Type of hose
- Type of fitting material
- Anticipated expansion and contraction of the hose
- Anticipated expansion and contraction of the fittings

Replace the Hoses and the Clamps

Refer to the OEM information for further information on removing and replacing fuel hoses (if equipped).

The following text describes a typical method of replacing coolant hoses. Refer to the OEM information for further information on the coolant system and the hoses for the coolant system.

WARNING

Pressurized System: Hot coolant can cause serious burns. To open the cooling system filler cap, stop the engine and wait until the cooling system components are cool. Loosen the cooling system pressure cap slowly in order to relieve the pressure.

1. Stop the engine. Allow the engine to cool.
2. Loosen the cooling system filler cap slowly to relieve any pressure. Remove the cooling system filler cap.

Note: Drain the coolant into a suitable, clean container. The coolant can be reused.

3. Drain the coolant from the cooling system to a level that is below the hose that is being replaced.
4. Remove the hose clamps.
5. Disconnect the old hose.
6. Replace the old hose with a new hose.
7. Install the hose clamps with a torque wrench.

Note: For the correct coolant, see this Operation and Maintenance Manual, "Fluid Recommendations".

8. Refill the cooling system. Refer to the OEM information for further information on refilling the cooling system.

9. Clean the cooling system filler cap. Inspect the cooling system filler cap's seals. Replace the cooling system filler cap if the seals are damaged. Install the cooling system filler cap.

10. Start the engine. Inspect the cooling system for leaks.

i09650780

Radiator - Clean

The radiator is not usually supplied by Perkins. The following text describes a typical cleaning procedure for the radiator. Refer to the OEM information for further information on cleaning the radiator.

Note: Adjust the frequency of cleaning according to the effects of the operating environment.

Inspect the radiator for these items: Damaged fins, corrosion, dirt, grease, insects, leaves, oil, and other debris. Clean the radiator, if necessary.

WARNING

Personal injury can result from air pressure.

Personal injury can result without following proper procedure. When using pressure air, wear a protective face shield and protective clothing.

Maximum air pressure at the nozzle must be less than 205 kPa (30 psi) for cleaning purposes.

Pressurized air is the preferred method for removing loose debris. Direct the air in the opposite direction to the air flow of the fan. Hold the nozzle approximately 6 mm (0.25 inch) away from the radiator fins. Slowly move the air nozzle in a direction that is parallel with the radiator tube assembly, which will remove debris that is between the tubes.

Pressurized water may also be used for cleaning. The maximum water pressure for cleaning purposes must be less than 275 kPa (40 psi). Use pressurized water to soften mud. Clean the core from the front and rear.

Use a degreaser and steam for removal of oil and grease. Clean the core from the front and rear. Wash the core with detergent and hot water. Thoroughly rinse the core with clean water.

If the radiator is blocked internally, refer to the OEM Manual for information regarding flushing the cooling system.

After cleaning the radiator, start the engine. Allow the engine to operate at low idle speed for three to five minutes. Accelerate the engine to high idle. Accelerating the engine to high idle will help in the removal of debris and the drying of the core. Slowly reduce the engine speed to low idle and then stop the engine. Use a light bulb behind the core to inspect the core for cleanliness. Repeat the cleaning, if necessary.

Inspect the fins for damage. Bent fins may be opened with a "comb". Inspect these items for good condition: Welds, mounting brackets, air lines, connections, clamps, and seals. Make repairs, if necessary.

i09630389

Radiator Mounts - Inspect

There are 2 anti vibration mounts (AVM) (2) on the radiator support bracket (1). The anti vibration mounts require inspection at specific maintenance intervals.

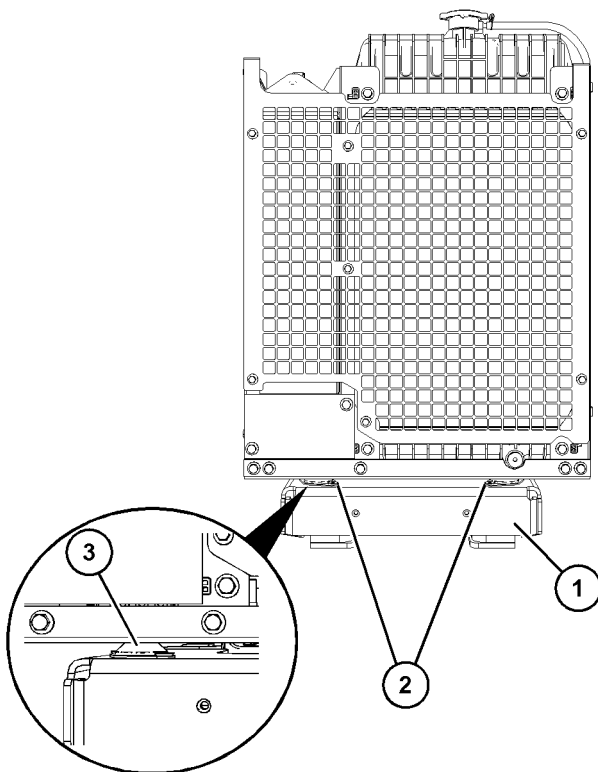

Illustration 127

g07520988

Typical example of a 4 cylinder IOPU

- (1) Radiator support bracket
- (2) Radiator anti vibration mounts
- (3) Radiator anti vibration mounts rubber compound

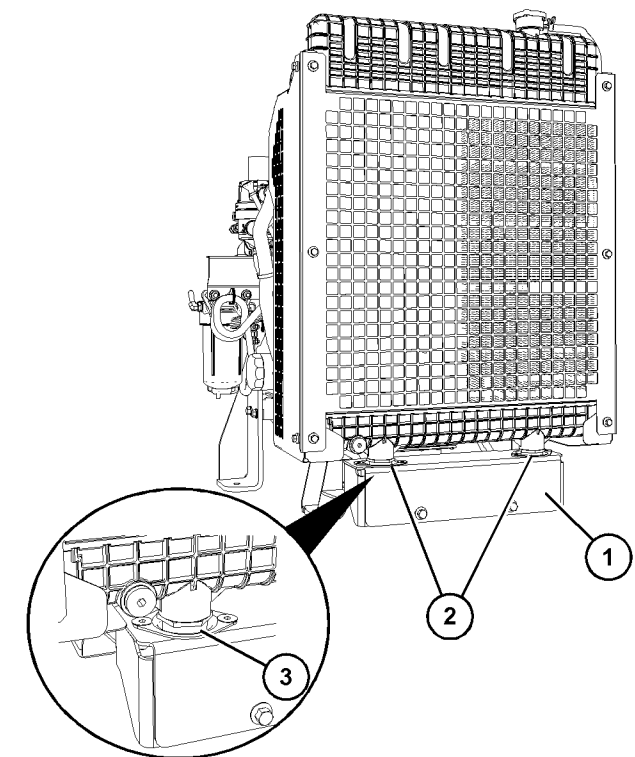

Illustration 128

g07520992

Typical example of a 3 cylinder IOPU

- (1) Radiator support bracket
- (2) Radiator anti vibration mounts
- (3) Radiator anti vibration mounts rubber compound

The radiator may need to be lifted to inspect the 2 anti vibration mounts (AVM). Refer to Disassembly and Assembly, Radiator - Remove and Install.

Inspect the anti vibration mounts for wear, cracking, and damage. If the anti vibration mounts appear to be worn, cracked, or damaged replace the anti vibration mount. Refer to Disassembly and Assembly, Radiator Anti Vibration Mounts - Remove and Install.

i07888480

Starting Motor - Inspect

Perkins recommends a scheduled inspection of the starting motor. If the starting motor fails, the engine may not start in an emergency situation.

Check the starting motor for correct operation. Check the electrical connections and clean the electrical connections. Refer to the Systems Operation, Testing and Adjusting Manual, "Electric Starting System - Test" for more information on the checking procedure and for specifications consult your Perkins dealer or your Perkins distributor for assistance.

i07824273

Turbocharger - Inspect

A regular visual inspection of the turbocharger is recommended. Any fumes from the crankcase are filtered through the air inlet system. Therefore, by-products from oil and from combustion can collect in the turbocharger compressor housing. Over time, this buildup can contribute to loss of engine power, increased black smoke and overall loss of engine efficiency.

If the turbocharger fails during engine operation, damage to the turbocharger compressor wheel and/or to the engine may occur. Damage to the turbocharger compressor wheel can cause damage to the pistons, the valves, and the cylinder head.

Refer to Systems Operation Testing and Adjusting, Air Inlet and Exhaust System - Inspect and Wastegate - Test for more information.

i07824276

Walk-Around Inspection

Inspect the Engine for Leaks and for Loose Connections

A walk-around inspection should only take a few minutes. When the time is taken to perform these checks, costly repairs and accidents can be avoided.

For maximum engine service life, make a thorough inspection of the engine compartment before starting the engine. Look for items such as fuel leaks, oil leaks, coolant leaks, loose bolts, worn belts, loose connections, and debris build-up. Make repairs, as needed:

- The guards must be in the correct place. Repair damaged guards or replace missing guards and fixings.
- Wipe all caps and plugs before the engine is serviced to reduce the chance of system contamination.

NOTICE

For any type of leak (coolant, lube, or fuel) clean up the fluid. If leaking is observed, find the source and correct the leak. If leaking is suspected, check the fluid levels more often than recommended until the leak is found or fixed, or until the suspicion of a leak is proved to be unwarranted.

NOTICE

Accumulated grease and/or oil on an engine is a fire hazard. Remove the accumulated grease and oil. Refer to this Operation and Maintenance Manual, "Engine - Clean" for more information.

- Ensure that the cooling system hoses are correctly clamped and that the cooling system hoses are tight. Check for leaks. Check the condition of all pipes.
- Inspect the water pump for coolant leaks.

Excessive coolant leakage may indicate the need to replace the water pump. Remove the water pump. Refer to Disassembly and Assembly, "Water Pump - Remove and Install" for the correct procedure.

- Inspect the lubrication system for leaks at the front crankshaft seal, the rear crankshaft seal, the oil pan, the oil filters, and the rocker cover.
- Inspect the piping for the air intake system and the elbows for cracks and for loose clamps. Ensure that hoses and tubes are not contacting other hoses, tubes, or the wiring harnesses.
- Ensure that the areas around the rotating parts are clear.
- Inspect the alternator belts and any accessory drive belts for cracks, breaks, or other damage.

Note: Belts for multiple groove pulleys must be replaced as matched sets. If only one belt is replaced, the belt will carry more load than the belts that are not replaced. The older belts are stretched. The additional load on the new belt could cause the belt to break.

- Inspect the wiring harness for damage.

High-Pressure Fuel Lines

WARNING

Contact with high pressure fuel may cause fluid penetration and burn hazards. High pressure fuel spray may cause a fire hazard. Failure to follow these inspection, maintenance and service instructions may cause personal injury or death.

NOTICE

Ensure that all adjustments and repairs that are carried out to the fuel system are performed by authorized personnel that have the correct training.

Before beginning ANY work on the fuel system, refer to this Operation and Maintenance Manual, "General Hazard Information and High-Pressure Fuel Lines" for safety information.

Refer to System Operation, Testing and Adjusting, "Cleanliness of Fuel System Components" for detailed information on the standards of cleanliness that must be observed during ALL work on the fuel system.

NOTICE

Care must be taken to ensure that fluids are contained during performance of inspection, maintenance, testing, adjusting and repair of the product. Be prepared to collect the fluid with suitable containers before opening any compartment or disassembling any component containing fluids.

Dispose of all fluids according to local regulations and mandates.

After the engine has stopped, wait 10 minutes to allow the fuel pressure to be purged from the high-pressure fuel lines before any service or repair is performed. The 10 minute wait will also allow static charge to dissipate from the low-pressure fuel system. If necessary, perform minor adjustments. Repair any leaks from the low-pressure fuel system and from the cooling, lubrication, or air systems. Replace any high-pressure fuel line that has leaked. Refer to Disassembly and Assembly Manual, "Fuel Injection Lines - remove" and Disassembly and Assembly Manual, "Fuel Injection Lines - Install" for the correct procedures.

If you inspect the engine in operation, always use the proper inspection procedure to avoid a fluid penetration hazard. Refer to Operation and Maintenance Manual, "General hazard Information".

Visually inspect the high-pressure fuel lines for damage or signs of fuel leakage. Replace any damaged high-pressure fuel lines or high-pressure fuel lines that have leaked.

Ensure that all clips on the high-pressure fuel lines are in place and that the clips are not loose.

- Inspect the rest of the fuel system for leaks. Look for loose fuel line clamps.
- Drain the water and the sediment from the fuel tank daily.

- Inspect the wiring and the wiring harnesses for loose connections and for worn wires or frayed wires. Check for any loose cable straps or missing cable straps.
- Inspect the ground strap for a good connection and for good condition.
- Disconnect any battery chargers that are not protected against the current drain of the starting motor. Check the condition and the electrolyte level of the batteries, unless the engine is equipped with a maintenance free battery.
- Check the condition of the gauges. Replace any gauges that are cracked. Replace any gauge that cannot be calibrated.

Engine Aftertreatment

Check that all clamps, clips, and cable straps are secure and in good condition.

i10048935

Water Pump - Inspect

A failed water pump may cause severe engine overheating problems that could result in the following conditions:

- Cracks in the cylinder head
 - A piston seizure
 - Other potential damage to the engine
1. Inspect the exterior components of the cooling system for coolant leakage. Refer to Systems Operation Testing and Adjusting, Cooling System - Check and Systems Operation Testing and Adjusting, Cooling System - Inspect for more information.

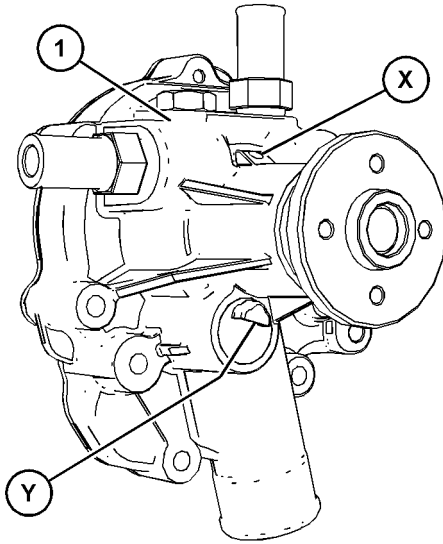

Illustration 129

g07525306

Typical example

2. If water pump (1) is leaking coolant and grease from the vent hole in Position (X), Perkins recommends that the water pump is replaced. Refer to Disassembly and Assembly for the correct procedure.

Note: A coolant leak from the vent hole in Position (X) means that the weep chamber is full, the weep hole in Position (Y) is blocked. Coolant may have entered the water pump bearing. The water pump bearing may eventually fail due to insufficient lubrication.

3. If the water pump is leaking coolant from vent hole in Position (Y), the coolant leak needs to be investigated.

Note: A small amount of coolant leakage across the surface of the seal for the jacket water pump is normal. This leakage is required to provide lubrication for this type of seal. A hole is provided in the water pump housing to allow this coolant/seal lubricant to drain from the water pump housing. Intermittent leakage of small amounts of coolant from this hole is not an indication of water pump seal failure.

Warranty Section

Warranty Information

i08757138

Emissions Warranty Information

The certifying engine manufacturer warrants to the ultimate purchaser and each subsequent purchaser that:

1. New non-road diesel engines and stationary diesel engines less than 10 L per cylinder (including Tier 1 and Tier 2 marine engines < 37 kW, but excluding locomotive and other marine engines) operated and serviced in the United States and Canada, including all parts of their emission control systems ("emission-related components"), are:
 - a. Designed, built, and equipped so as to conform, at the time of sale, with applicable emission standards prescribed by the United States Environmental Protection Agency (EPA) by way of regulation.
 - b. Free from defects in materials and workmanship in emission-related components that can cause the engine to fail to conform to applicable emission standards for the warranty period.
2. New non-road diesel engines (including Tier 1 and Tier 2 marine propulsion engines < 37 kW and Tier 1 through Tier 4 marine auxiliary engines < 37 kW, but excluding locomotive and other marine engines) operated and serviced in the state of California, including all parts of their emission control systems ("emission-related components"), are:
 - a. Designed, built, and equipped so as to conform, at the time of sale, to all applicable regulations adopted by the California Air Resources Board (ARB).
 - b. Free from defects in materials and workmanship which cause the failure of an emission-related component to be identical in all material respects to the component as described in the engine manufacturer's application for certification for the warranty period.
3. New non-road diesel engines installed in construction machines conforming to the South Korean regulations for construction machines manufactured after January 1, 2015, and operated and serviced in South Korea, including all parts of their emission control systems ("emission related components"), are:
 - a. Designed, built, and equipped so as to conform, at the time of sale, with applicable emission standards prescribed in the Enforcement Rule of the Clean Air Conservation Act promulgated by South Korea MOE.
 - b. Free from defects in materials and workmanship in emission-related components that can cause the engine to fail to conform to applicable emission standards for the warranty period.
4. New China non-road 4 mobile diesel engines operated and serviced in China, including all parts of their emission control systems ("emission related components"), are:
 - a. Designed, built, and equipped so as to conform, at the time of manufacture, sale, and import with applicable emission standards promulgated by Ministry of Ecology and Environment (MEE).
 - b. Free from defects in materials and workmanship in emission-related components that can cause the engine to fail to conform to applicable emission standards for the warranty period.

A detailed explanation of the Emission Control Warranty that is applicable to new non-road and stationary diesel engines, including the components covered and the warranty period, is found in Warranty supplement - Emission warranty parts available at the Perkins engines website. Consult your authorized Perkins distributor to determine if your engine is subject to an Emission Control Warranty, and to obtain a copy of the applicable warranty publication.

Reference Information Section

Reference Materials

i05204675

Maintenance Log

Table 25

Engine Model		Customer Identifier		
Serial Number		Arrangement Number		
Service Hours	Quantity Of Fuel	Service Item	Date	Authorization

(continued)

(Table 25, contd)

i04224089

Engine Protection Plans (Extended Service Contract)

Extended Service Contracts-purchased in minutes, protected for years.

Extended Service Contracts (ESC) protect you from the stress that unexpected repair work brings to your life by covering the cost of getting your engine up and running again. Unlike other extended warranties, Perkins Platinum ESC protects you against all component part failures.

Purchase peace of mind from only £0.03 / \$0.05 / euro 0.04 a day and let an ESC make your dreams a reality.

Why buy an Extended Service Contract?

1. No surprises - total protection from unexpected repair cost (parts, labor, and travel).
2. Enjoy longer lasting product support from Perkins global network.
3. Genuine Perkins parts ensure continued engine performance.
4. Highly trained technicians carry out all repairs.
5. Transferable coverage should you sell your machine.

Flexible coverage provides the right level of protection for your Perkins Engine. Coverage can be extended to 2 years/ 1,000 hours right up to 10 year/ 40,000

You can buy an ESC at any time during standard warranty - even the last day!

Each Perkins Distributor has highly trained and experienced Perkins Product Support Service Technicians. The Support Service are equipped, and available around the clock to get your engine running again with the minimum of downtime. Buying an ESC means that you get all this for free.

To purchase an Extended Service Contract, is quick and simple! Contact your local Perkins Distributor now and the distributor can provide you with a quote in minutes. You can locate your nearest Perkins Distributor by visiting:

www.perkins.com

NOTICE
 Dependant upon engine type and application.

Index

A

After Starting Engine	68
After Stopping Engine	75
Aftercooler Core - Inspect	99
Alarms and Shutoffs	58
Alarms	58
Shutoffs	58
Alternator - Inspect	99
Alternator and Fan Belts - Replace (Multi-V Stretch Belt)	99
Engines Equipped with a Balancer	101
Installation Procedure	100
Removal Procedure	99
Alternator and Fan Belts - Replace (Single- V Belt)	102
Installation Procedure	103
Removal Procedure	102

B

Battery - Replace	103
Battery Electrolyte Level - Check	104
Battery or Battery Cable - Disconnect	104
Before Starting Engine	27, 65
Belts - Inspect/Adjust	104
Adjust	105
Engines Equipped with a Balancer	105
Inspection	104
Burn Prevention	20
Batteries	22
Coolant	21
Diesel Fuel	21
Engine and Aftertreatment System	22
Induction System	21
Oils	21

C

Cold Weather Operation	71
Hints for Cold-Weather Operation	71
Idling the Engine	72
Recommendations for Coolant Warm Up	72
Recommendations for the Coolant	72
Viscosity of the Engine Lubrication Oil	72
Cold Weather Starting	65
Configuration Parameters	64
Coolant (Commercial Heavy-Duty) - Change	105
Drain	106

Drain Plug for ElectropaK Radiator	109
Drain Plugs for Factory Installed Radiators	108
Drain Plugs for IOPU Radiators	107
Fill	109
Flush	109
Coolant (ELC) - Change	110
Drain	110
Drain Plug for ElectropaK Radiator	114
Drain Plugs for Factory Installed Radiators	113
Drain Plugs for IOPU Radiators	112
Fill	114
Flush	114
Coolant Level - Check	115
Factory Installed Radiators	117
Industrial Open Power Unit (IOPU) Radiators	116
Radiator Cap for Factory Installed Radiators	118
Radiator Cap for IOPU Radiators	118
Coolant Temperature Regulator - Replace	118
Crankcase Breather (Element) - Replace (Closed Crankcase Breather)	119
Crankcase Breather (Element) - Replace (Open Crankcase Breather)	120
Crushing Prevention and Cutting Prevention	24

E

Electrical System	28
Grounding Practices	29
Emergency Stopping	75
Emissions Certification Film	51
Emissions Warranty Information	147
Engaging the Driven Equipment	70
Engine - Clean	122
Aftertreatment	123
Engine Air Cleaner Element - Replace	123
Servicing the Air Cleaner Elements	123
Engine Air Cleaner Service Indicator - Inspect	124
Test the Service Indicator	125
Type 1 Service Indicator	124
Type 2 Service Indicator	124
Engine Air Precleaner - Check/Clean	125
Engine Diagnostics	64
Engine Electronics	29
Engine Mounts - Inspect	125

Engine Oil and Filter - Change	126	Maintenance Intervals	5
Drain the Engine Lubricating Oil From a Standard Oil Pan.....	127	Operation	4
Draining the Engine Lubricating Oil from an Engine Equipped with a Balancer.....	128	Overhaul	5
Fill the Engine Crankcase.....	129	Safety.....	4
Oil analysis	126	Fuel and the Effect from Cold Weather	73
Replace the Oil Filter	129	Fuel Conservation Practices	70
Engine Oil Level - Check.....	126	Fuel Related Components in Cold Weather ...	74
Engine Operation	69	Fuel Filters	74
Carbon Dioxide (CO ₂) Emissions Statement.....	69	Fuel Heaters	74
Engine Operation and the Aftertreatment System	69	Fuel Tanks	74
Engine Operation with Active Diagnostic Codes	64	Fuel System - Prime.....	131
Engine Operation with Intermittent Diagnostic Codes	64	Hand Priming (If Equipped)	133
Engine Protection Plans (Extended Service Contract).....	149	Fuel System Primary Filter (Water Separator) Element - Replace.....	133
Engine Starting.....	28, 65	Remove the Element.....	133
Engine Stopping.....	28, 75	Fuel System Primary Filter (Water Separator) Element - Replace (Primary Fuel Filter With Water In Fuel (WIF) Sensor)	134
Engine Valve Lash - Check	130	Install the New Filter Element.....	135
F		Remove the Element	134
Fan Clearance - Check	130	Fuel System Primary Filter/Water Separator	137
Factory Installed Radiators.....	131	Fuel System Primary Filter/Water Separator - Drain (Primary Fuel Filter With Water In Fuel (WIF) Sensor)	136
Industrial Open Power Unit (IOPU) Radiators.....	130	Fuel System Secondary Filter - Replace	138
Fault Logging.....	64	Remove the Filter Element	138
Features and Controls.....	58	Fuel System Secondary Filter/Water Separator - Drain	140
Fire Prevention and Explosion Prevention.....	22	Fuel Tank Water and Sediment - Drain	140
Ether	23	Drain the Water and the Sediment	141
Fire Extinguisher.....	23	Fuel Storage Tanks.....	141
Lines, Tubes, and Hoses	24	Fuel Tank	140
Fluid Recommendations	86, 92	G	
ELC Cooling System Maintenance.....	89	Gauges and Indicators	58
Engine Oil	92	General Hazard Information.....	17
General Coolant Information	86	Containing Fluid Spillage.....	18
General Lubricant Information.....	92	Dispose of Waste Properly	20
Fluid Recommendations (General Fuel Information)	78	Fluid Penetration	18
Contamination Control Recommendations for Fuels	85	Inhalation	19
Diesel Fuel Characteristics.....	81	Pressurized Air and Water.....	18
Diesel Fuel Requirements	78	Static Electricity Hazard when Fueling with Ultra-low Sulfur Diesel Fuel	19
General Information.....	78	General Information	31
Foreword	4	H	
California Proposition 65 Warning.....	4	High Pressure Fuel Lines	24
Literature Information	4	Four Cylinder engine	26
Maintenance	4		

Three Cylinder Engine	27	Overspeed	61
Hoses and Clamps - Inspect/Replace	141		
Replace the Hoses and the Clamps	142	P	
I		Plate Locations and Film Locations	51
Important Safety Information	2	Serial Number Plate	51
L		Product Description	48
Lifting and Storage	53	Aftermarket Products and Perkins	
		Engines	50
M		Aftertreatment System	49
Maintenance Interval Schedule	98	Electronic Engine Features	50
Commissioning	98	Engine Diagnostics	50
Daily	98	Engines Equipped with a Balancer	49
Every 1000 Service Hours	98	Four Cylinder Engine 404J-E22T and 404J-	
Every 1500 Service Hours	98	E22TA	49
Every 2000 Service Hours	98	Service Life	50
Every 3000 Service Hours	98	Three Cylinder Engine 403J-E17T	48
Every 3000 Service Hours or 2 Years	98	Product Identification Information	51
Every 4000 Service Hours	98	Product Information Section	31
Every 50 Service Hours or Weekly	98	Product Lifting	53
Every 500 Service Hours	98	Aftertreatment Systems for Engine Equipped	
Every 500 Service Hours or 1 Year	98	with a Balancer	54
Every 6000 Service Hours or 3 Years	98	ElectropaK	55
When Required	98	Engine and Aftertreatment	53
Maintenance Log	148	Engine Equipped with a Balancer	54
Maintenance Recommendations	95	Industrial Open Power Unit (IOPU)	54
Maintenance Section	76	Product Storage (Engine and	
Model View Illustrations	31	Aftertreatment)	56
ElectropaK	46	Condition for Storage	56
Four Cylinder Engine	36		
Industrial Engine Views For Engines		R	
Equipped With A Balancer	39	Radiator - Clean	142
Industrial Open Power Unit (IOPU)	44	Radiator Mounts - Inspect	143
Off Engine Components for Three and Four		Reference Information	52
Cylinder Engines	43	Record for Reference	52
Off Engine Components for Three or Four		Reference Information Section	148
Cylinder IOPU and ElectropaK	48	Reference Materials	148
Three Cylinder Engine	32	Refill Capacities	76
Monitoring System	59	Cooling System	77
Programmable Options and Systems		Lubrication System	76
Operation	59		
Monitoring System (Engine Warning		S	
Indicators)	61	Safety Messages	6
Mounting and Dismounting	24	(1) Universal Warning	6
		(2) Hand (High Pressure)	7
O		(3) Ether Warning	8
Operation Section	53	ElectropaK	14
		Industrial Open Power Unit (IOPU)	
		Engines	9
		Safety Section	6

Sensors and Electrical Components	61
Severe Service Application	97
Environmental Factors	97
Incorrect Maintenance Procedures	97
Incorrect Operating Procedures	97
Starting Motor - Inspect	143
Starting the Engine	66
Starting the Engine	66
Starting with Jump Start Cables (Do Not Use This Procedure in Hazardous Locations that have Explosive Atmospheres)	67
Stopping the Engine	75
System Pressure Release	95
Coolant System	95
Engine Oil	95
Fuel System	95

T

Table of Contents	3
Turbocharger - Inspect	144

W

Walk-Around Inspection	144
High-Pressure Fuel Lines	144
Inspect the Engine for Leaks and for Loose Connections	144
Warranty Information	147
Warranty Section	147
Water Pump - Inspect	145
Welding on Engines with Electronic Controls	95

Product and Dealer Information

Note: For product identification plate locations, see the section "Product Identification Information" in the Operation and Maintenance Manual.

Delivery Date: _____

Product Information

Model: _____

Product Identification Number: _____

Engine Serial Number: _____

Transmission Serial Number: _____

Generator Serial Number: _____

Attachment Serial Numbers: _____

Attachment Information: _____

Customer Equipment Number: _____

Dealer Equipment Number: _____

Dealer Information

Name: _____ Branch: _____

Address: _____

Dealer Contact

Phone Number

Hours

Sales: _____

Parts: _____

Service: _____

