

CAT® C2.2

EU STAGE V/U.S. EPA TIER 4 FINAL/JAPAN 2014 (TIER 4 FINAL)

55 kW (74 HP) @ 2800 RPM

INDUSTRIAL POWER UNIT (IPU)



The Cat® C2.2 IPU is a turbocharged aftercooled, common rail direct injection engine meeting EU Stage V, U.S. EPA Tier 4 Final and Japan 2014 (Tier 4 Final) emission standards. For ease of installation, the IPU provides full aftertreatment mounting, an integrated cooling system, a full wiring harness and mounted air filter.

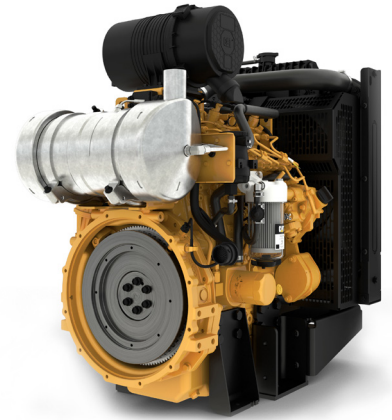

FEATURES AND BENEFITS

Easy integration for OEMs

Fully integrated from the factory, with aftertreatment and air filter ready mounted to the IPU offering a wide range of options to suit your application in agriculture, material handling, construction, mining, aircraft ground support, and many other industries.

Reliable and Durable Power for Customers

World-class manufacturing capability and processes coupled with proven technologies, offer improved power density up 10 percent and 30 percent improvement in peak torque over the previous generation turbocharged aftercooled C2.2, allowing you to downsize, saving installation space on your products. And with our extensive field validation, our IPU's save you engineering development time and costs.

Simple Service for Technicians

Worldwide dealer support from concept to completion and beyond, parts, training and service are never far. Combine that with easy maintenance, simplified servicing, 500 hour oil change interval, and factory fitted fit-for-life diesel particulate filter with no downtime for regeneration and you've got a Cat® powered product ready to take on your toughest tasks.

SPECIFICATION

Cylinders	4
Displacement, litres (in ³)	2.2 (135)
Aspiration	Turbocharged aftercooled
Bore and stroke, mm (in)	84 x 100 (3.3 x 3.9)
Maximum power, kW (hp)	55 (74)
Rated speed, rpm	2800
Maximum torque, Nm (lb ft) @ rpm	270 (199) @ 1600
Combustion system	Direct injection
Weight, kg (lb)	327 (721) dry / 344 (758) wet
Rotation (viewed from flywheel)	Anti-clockwise

For additional information on all your power requirements, visit www.cat.com/industrial

All information in this document is substantially correct at time of printing and may be altered subsequently.
Photographs are for illustrative purposes only and may not reflect final specification.
Final weight and dimensions will depend on completed specification.
Information subject to selected configuration, and subject to change without notice.
Engine power measured per ISO 14396:2002

AEXJ0158-01 (11-23)

© 2023 Caterpillar. All Rights Reserved. CAT, CATERPILLAR, LET'S DO THE WORK, their respective logos, "Caterpillar Corporate Yellow", the "Power Edge" and Cat "Modern Hex" trade dress as well as corporate and product identity used herein, are trademarks of Caterpillar and may not be used without permission.

CAT® C2.2

EU STAGE V/U.S. EPA TIER 4 FINAL/JAPAN 2014 (TIER 4 FINAL)

55 kW (74 HP) @ 2800 RPM



INDUSTRIAL POWER UNIT (IPU)

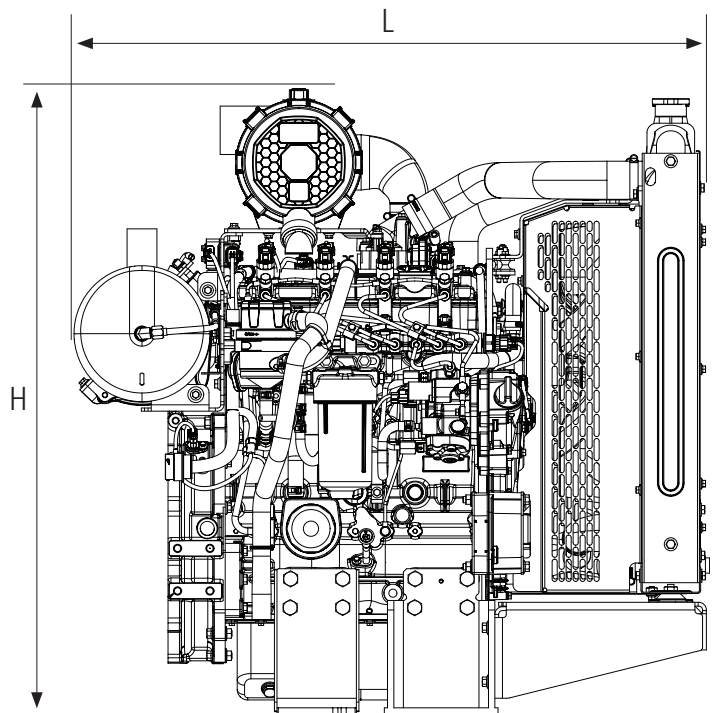
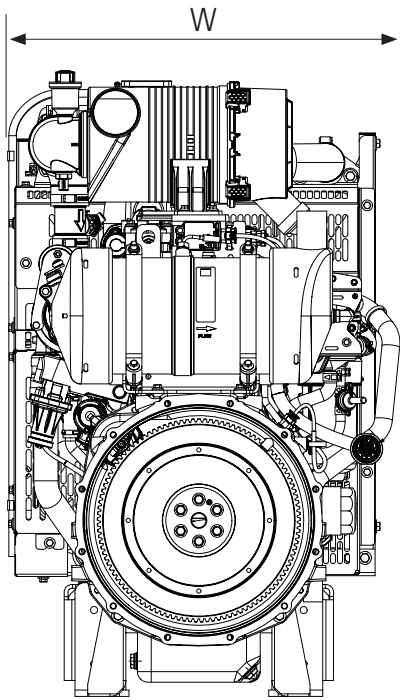
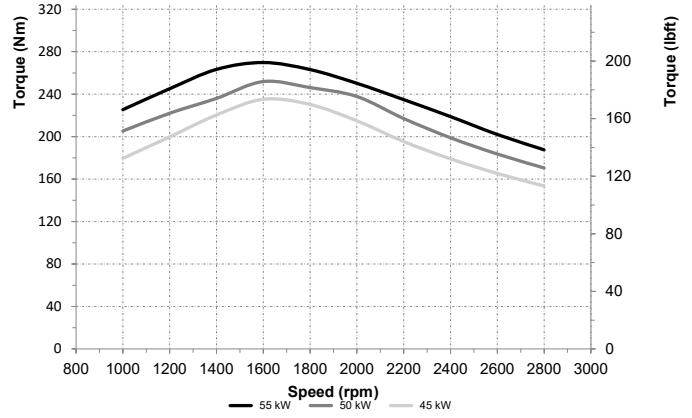
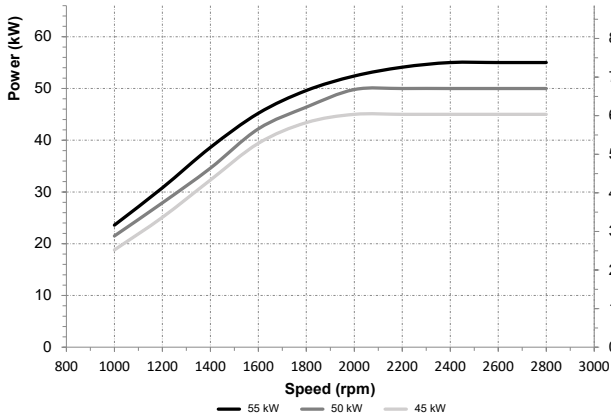

Length (including fan), mm (in)	992 (39.1)
Width, mm (in)	602 (23.7)
Height, mm (in)	985 (38.8)
Weight, kg (lb)	327 (721) dry / 344 (758) wet

For additional information on all your power requirements, visit www.cat.com/industrial

All information in this document is substantially correct at time of printing and may be altered subsequently. Photographs are for illustrative purposes only and may not reflect final specification. Final weight and dimensions will depend on completed specification. Information subject to selected configuration, and subject to change without notice. Engine power measured per ISO 14396:2002

AEXJ0158-01 (11-23)

© 2023 Caterpillar. All Rights Reserved. CAT, CATERPILLAR, LET'S DO THE WORK, their respective logos, "Caterpillar Corporate Yellow", the "Power Edge" and Cat "Modern Hex" trade dress as well as corporate and product identity used herein, are trademarks of Caterpillar and may not be used without permission.