



773

Off-Highway Truck

Technical Specifications

Configurations and features may vary by region. Please consult your Cat® dealer for availability in your area.

Table of Contents

Specifications	2
Engine – Meets U.S. EPA Tier 4 Final/EU Stage V emission standards	2
Engine – Emits equivalent to U.S. EPA Tier 2	2
Transmission – Tier 4 Final/Stage V	2
Transmission – Tier 2 Equivalent	2
Final Drives	2
Brakes	2
Body Hoists – Tier 4 Final/Stage V	2
Body Hoists – Tier 2 Equivalent	2
Capacity – Dual Slope – 100% Fill Factor	3
Capacity – Flat Floor – 100% Fill Factor	3
Weight Distributions – Approximate	3
Suspension	3
Sound	3
Air Conditioning System	3
Steering	3
Rollover Protective Structure (ROPS)/Falling Objects Protective Structure (FOPS)	3
Tires	3
Service Refill Capacities	3
Weight/Payload Calculation – Tier 4 Final/Stage V Examples	4
Weight/Payload Calculation – Tier 2 Equivalent Examples	6
10/10/20 Payload Management Policy for Optimal Machine Life	8
Dimensions	9
Retarding Performance – Tier 4 Final/Stage V	10
Gradeability/Speed/Rimpull – Tier 4 Final/Stage V	13
Retarding Performance – Tier 2 Equivalent	14
Gradeability/Speed/Rimpull – Tier 2 Equivalent	17
Standard and Optional Equipment	18
773 Environmental Declaration	20

773 Off-Highway Truck Specifications

Engine – U.S. EPA Tier 4 Final/EU Stage V

Engine Model	Cat® C27	
Rated Speed	1,800 rpm	
Gross Power – SAE J1995	578 kW	775 hp
Net Power – SAE J1349	534 kW	717 hp
Net Power – ISO 9249	540 kW	724 hp
Net Power – 80/1269/EEC	540 kW	724 hp
Engine Power – ISO 14396	568 kW	762 hp
Net Torque Speed	1,200 rpm	
Net Torque	3992 N·m	2,944 lb-ft
Bore	137 mm	5.4 in
Stroke	152 mm	6 in
Displacement	27 L	1,648 in ³

- Power rating applies at 1,800 rpm when tested under the specified condition for the specified standard.
- Net power advertised is the power available at the flywheel when the engine is equipped with fan at minimum speed, air intake system, exhaust system, and alternator.
- Advertised power is tested per the specified standard in effect at the time of manufacture.
- No engine derating required up to 3048 m (10,000 ft).
- Meets U.S. EPA Tier 4 Final and EU Stage V emission standards.

Engine – U.S. EPA Tier 2 Equivalent

Engine Model	Cat C27	
Rated Speed	2,000 rpm	
Gross Power – SAE J1995	578 kW	775 hp
Net Power – SAE J1349	546 kW	733 hp
Net Power – ISO 9249	552 kW	741 hp
Net Power – 80/1269/EEC	552 kW	741 hp
Engine Power – ISO 14396	569 kW	763 hp
Net Torque Speed	1,300 rpm	
Net Torque	3646 N·m	2,689 lb-ft
Bore	137 mm	5.4 in
Stroke	152 mm	6 in
Displacement	27 L	1,648 in ³

- Power rating applies at 2,000 rpm when tested under the specified condition for the specified standard.
- Net power advertised is the power available at the flywheel when the engine is equipped with fan at minimum speed, air intake system, exhaust system, and alternator.
- Advertised power is tested per the specified standard in effect at the time of manufacture.
- No engine derating required up to 3810 m (12,500 ft).
- Equivalent to U.S. EPA Tier 2.

Transmission – Tier 4 Final/Stage V

Forward 1	10.6 km/h	6.6 mph
Forward 2	15.0 km/h	9.3 mph
Forward 3	20.3 km/h	12.6 mph
Forward 4	27.0 km/h	16.8 mph
Forward 5	36.7 km/h	22.8 mph
Forward 6	49.4 km/h	30.7 mph
Forward 7	66.9 km/h	41.6 mph
Reverse	14.0 km/h	8.7 mph

- Maximum travel speeds with standard 24.00R35 (E4) tires.

Transmission – Tier 2 Equivalent

Forward 1	10.8 km/h	6.7 mph
Forward 2	15.1 km/h	9.4 mph
Forward 3	20.4 km/h	12.7 mph
Forward 4	27.4 km/h	17.0 mph
Forward 5	37.0 km/h	23.0 mph
Forward 6	50.1 km/h	31.1 mph
Forward 7	67.6 km/h	42.0 mph
Reverse	14.1 km/h	8.8 mph

- Maximum travel speeds with standard 24.00R35 (E4) tires.

Final Drives

Differential Ratio	3.64:1
Planetary Ratio	4.80:1
Total Reduction Ratio	17.49:1

Brakes

Brake Surface – Front	655 cm ²	257 in ²
Brake Surface – Rear	61 269 cm ²	9,497 in ²
Brake Standards	ISO 3450:2011	

Body Hoists – Tier 4 Final/Stage V

Pump Flow – High Idle	448 L/min	118 gal/min
Relief Valve Setting – Raise	17 250 kPa	2,502 psi
Relief Valve Setting – Lower	3450 kPa	500 psi
Body Raise Time – High Idle	10.0 seconds	
Body Lower Time – Float	14.0 seconds	
Body Power Down – High Idle	14.0 seconds	

Body Hoists – Tier 2 Equivalent

Pump Flow – High Idle	448 L/min	118 gal/min
Relief Valve Setting – Raise	17 250 kPa	2,502 psi
Relief Valve Setting – Lower	3450 kPa	500 psi
Body Raise Time – High Idle	9.5 seconds	
Body Lower Time – Float	13.0 seconds	
Body Power Down – High Idle	13.0 seconds	

Capacity – Dual Slope – 100% Fill Factor

Struck	26.86 m ³	35.13 yd ³
Heaped (SAE 2:1)*	35.75 m ³	46.76 yd ³

- Contact your local Cat dealer for body recommendation.
- *ISO 6483:1980

Capacity – Flat Floor – 100% Fill Factor

Struck	26.25 m ³	34.33 yd ³
Heaped (SAE 2:1)*	35.49 m ³	46.41 yd ³

- Contact your local Cat dealer for body recommendation.
- *ISO 6483:1980

Weight Distributions – Approximate

Front Axle – Empty	53%
Front Axle – Loaded	35%
Rear Axle – Empty	47%
Rear Axle – Loaded	65%

Suspension

Empty Loaded Cylinder Stroke Front	234 mm	9.2 in
Empty Loaded Cylinder Stroke Rear	149 mm	5.8 in
Rear Axle Oscillation	8.1°	

Sound

Sound Standards

- The operator Equivalent Sound Pressure Level (Leq) is 76 dB(A) when SAE J1166 FEB2008 is used to measure the value for an enclosed cab. This is a work cycle sound exposure level. The cab was properly installed and maintained. The test was conducted with the cab doors and the cab windows closed.
- The exterior sound pressure level for the standard machine measured at a distance of 15 m (49 ft) according to the test procedures specified in SAE J88:2008, mid-gear moving operation is 86 dB(A).
- Hearing protection may be needed when operating with an open operator station and cab (when not properly maintained or doors/windows open) for extended periods or in a noisy environment.

Air Conditioning System

The air conditioning system on this machine contains the fluorinated greenhouse gas refrigerant R134a (Global Warming Potential = 1430). The system contains 2.0 kg (4.4 lb) of refrigerant which has a CO₂ equivalent of 2.86 metric tonnes (3.152 tons).

Steering

Steering Standards	ISO 5010:2007	
Steer Angle	31°	
Turning Diameter – Front	23.5 m	77 ft 1 in
Turning Circle Clearance Diameter	26.1 m	85 ft 8 in

ROPS/FOPS

Rollover Protective Structure (ROPS)/Falling Objects Protective Structure (FOPS) Standards

- ROPS for cab offered by Caterpillar meets ISO 3471:2008 for operator and ISO 13459:2012 for trainer ROPS criteria.
- FOPS meets ISO 3449:2005 Level II for operator and ISO 13459:2012 Level II for trainer FOPS criteria.

Tires

Standard Tire	24.00R35 (E4)
---------------	---------------

- Productive capabilities of the 773 truck are such that, under certain job conditions, tons kilometers per hour (TKPH)/tons miles per hour (TMPH) capabilities of standard or optional tires could be exceeded and, therefore, limit production.
- Caterpillar recommends the customer evaluate all job conditions and consult the tire manufacturer for proper tire selection.

Service Refill Capacities

Fuel Tank	795 L	210.0 gal
Cooling System	171 L	45.0 gal
Crankcase	90 L	24.0 gal
Differentials and Final Drives	145 L	38.0 gal
Steering Tank	36 L	9.5 gal
Steering System (includes tank)	54 L	14.0 gal
Brake/Hoist Hydraulic Tank	176 L	46.5 gal
Brake Hoist System	322 L	85.0 gal
Torque Converter/Transmission System HRC	70 L	18.0 gal
Torque Converter/Transmission System LRC	61 L	16.0 gal

773 Off-Highway Truck Specifications

Weight/Payload Calculation – Tier 4 Final/Stage V Examples

773 – Flat Floor		Base Body	Base Body/Liner	Rubber Liner
Floor/Sidewall/Frontwall	mm (in)	20/10/12 (0.79/0.39/0.47)	36/18/22 (1.42/0.71/0.87)	102/8/8 + 20/10/12 (4.0/0.31/0.31) + (0.79/0.39/0.47)
Payload Capacity	m ³ (yd ³)	35.5 (46.4)	35.0 (45.8)	33.3 (43.6)
	mm (in)	20 (0.787)	36 (1.42)	102 (4.0)
Target Gross Machine Weight	kg (lb)	102 740 (226,503)	102 740 (226,503)	102 740 (226,503)
Empty Chassis Weight	kg (lb)	34 522 (76,107)	34 522 (76,107)	34 522 (76,107)
Body System Weight	kg (lb)	11 423 (25,183)	15 217 (33,547)	15 997 (35,267)
Empty Machine Weight	kg (lb)	45 945 (101,290)	49 739 (109,654)	50 519 (111,374)
Attachments				
Fuel Tank Size	L (gal)	795 (210)	795 (210)	795 (210)
Fuel Tank – 100% Fill	kg (lb)	669 (1,474)	669 (1,474)	669 (1,474)
Empty Operating Weight	kg (lb)	46 614 (102,764)	50 407 (111,128)	51 188 (112,848)
Target Payload (100%)*	kg (lb)	56 126 (123,739)	52 333 (115,375)	51 552 (113,655)
Target Payload Material Density	tonnes (tons)	56.1 (61.9)	52.3 (57.7)	51.6 (56.8)
Maximum Payload (110% of Target)*	kg (lb)	56 126 (123,739)	52 333 (115,375)	51 552 (113,655)
Maximum Payload Material Density	kg (lb)	61 739 (136,112)	57 566 (126,912)	56 708 (125,020)
Not to Exceed Payload (120% of Target)*	kg (lb)	67 352 (148,486)	62 799 (138,449)	61 863 (136,385)
Not to Exceed Payload Material Density	kg (lb)	113 965 (251,251)	113 207 (249,578)	113 050 (249,234)

*Refer to Caterpillar 10/10/20 Payload Policy.

773 Off-Highway Truck Specifications

Weight/Payload Calculation – Tier 4 Final/Stage V Examples

773 – Dual Slope		Base Body	Base Body/Liner	No Rubber Liner Offered
Floor/Sidewall/Frontwall	mm (in)	20/10/12 (0.79/0.39/0.47)	36/18/22 (1.42/0.71/0.87)	
Payload Capacity	m ³ (yd ³)	35.8 (46.8)	35.2 (46.0)	
	mm (in)	20 (0.787)	36 (1.42)	
Target Gross Machine Weight	kg (lb)	102 740 (226,503)	102 740 (226,503)	
Empty Chassis Weight	kg (lb)	34 522 (76,107)	34 522 (76,107)	
Body System Weight	kg (lb)	11 049 (24,358)	14 776 (32,575)	
Empty Machine Weight	kg (lb)	45 570 (100,464)	49 298 (108,683)	
Attachments				
Fuel Tank Size	L (gal)	795 (210)	795 (210)	
Fuel Tank – 100% Fill	kg (lb)	669 (1,474)	669 (1,474)	
Empty Operating Weight	kg (lb)	46 239 (101,939)	49 967 (110,158)	
Target Payload (100%)*	kg (lb)	56 501 (124,564)	52 773 (116,345)	
Target Payload Material Density	tonnes (tons)	56.5 (62.3)	52.8 (58.2)	
Maximum Payload (110% of Target)*	kg (lb)	56 501 (124,564)	52 773 (116,345)	
Maximum Payload Material Density	kg (lb)	62 152 (137,020)	58 051 (127,980)	
Not to Exceed Payload (120% of Target)*	kg (lb)	67 802 (149,477)	63 328 (139,614)	
Not to Exceed Payload Material Density	kg (lb)	114 040 (251,416)	113 295 (249,772)	

*Refer to Caterpillar 10/10/20 Payload Policy.

Sideboards (optional)

Height		Volume Add		Weight		Maximum (110%) Material Density**	
mm	(in)	m ³	(yd ³)	kg	(lb)	kg	(lb)
155	(6.0)	2.9	(3.8)	430	(948)	1681	(342)

**Based on Quarry Body at 90% Body Volume Fill.

Empty Chassis Weight is figured without fuel.

Payload Calculation: Definitions

Empty Machine Weight = Empty Chassis Weight + Body System Weight

Target Payload = Target Gross Machine Weight less Empty Machine Weight

Maximum Payload = Target Payload × 1.10 (110%)

773 Off-Highway Truck Specifications

Weight/Payload Calculation – Tier 2 Equivalent Examples

773 – Flat Floor		Base Body	Base Body/Liner	Rubber Liner
Floor/Sidewall/Frontwall	mm (in)	20/10/12 (0.79/0.39/0.47)	36/18/22 (1.42/0.71/0.87)	102/8/8 + 20/10/12 (4.0/0.31/0.31) + (0.79/0.39/0.47)
Payload Capacity	m ³ (yd ³)	35.5 (46.4)	35.0 (45.8)	33.3 (43.6)
	mm (in)	20 (0.787)	36 (1.42)	102 (4.0)
Target Gross Machine Weight	kg (lb)	102 740 (226,503)	102 740 (226,503)	102 740 (226,503)
Empty Chassis Weight	kg (lb)	33 867 (74,663)	33 867 (74,663)	33 867 (74,663)
Body System Weight	kg (lb)	11 423 (25,183)	15 217 (33,547)	15 997 (35,267)
Empty Machine Weight	kg (lb)	45 290 (99,846)	49 084 (108,210)	49 864 (109,930)
Attachments				
Fuel Tank Size	L (gal)	795 (210)	795 (210)	795 (210)
Fuel Tank – 100% Fill	kg (lb)	669 (1,474)	669 (1,474)	669 (1,474)
Empty Operating Weight	kg (lb)	45 959 (101,322)	49 752 (109,684)	50 533 (111,406)
Target Payload (100%)*	kg (lb)	56 781 (125,181)	52 988 (116,819)	52 207 (115,097)
Target Payload Material Density	tonnes (tons)	56.8 (62.6)	53.0 (58.4)	52.2 (57.5)
Maximum Payload (110% of Target)*	kg (lb)	56 781 (125,181)	52 988 (116,819)	52 207 (115,097)
Maximum Payload Material Density	kg (lb)	62 460 (137,699)	58 287 (128,500)	57 428 (126,607)
Not to Exceed Payload (120% of Target)*	kg (lb)	68 138 (150,217)	63 585 (140,182)	62 649 (138,116)
Not to Exceed Payload Material Density	kg (lb)	114 096 (251,539)	113 338 (249,867)	113 181 (249,522)

*Refer to Caterpillar 10/10/20 Payload Policy.

Weight/Payload Calculation – Tier 2 Equivalent Examples

773 – Dual Slope		Base Body	Base Body/Liner	No Rubber Liner Offered
Floor/Sidewall/Frontwall	mm (in)	20/10/12 (0.79/0.39/0.47)	36/18/22 (1.42/0.71/0.87)	
Payload Capacity	m ³ (yd ³)	35.8 (46.8)	35.2 (46.0)	
	mm (in)	20 (0.787)	36 (1.42)	
Target Gross Machine Weight	kg (lb)	102 740 (226,503)	102 740 (226,503)	
Empty Chassis Weight	kg (lb)	33 867 (74,663)	33 867 (74,663)	
Body System Weight	kg (lb)	11 049 (24,358)	14 776 (32,575)	
Empty Machine Weight	kg (lb)	44 916 (99,022)	48 643 (107,239)	
Attachments				
Fuel Tank Size	L (gal)	795 (210)	795 (210)	
Fuel Tank – 100% Fill	kg (lb)	669 (1,474)	669 (1,474)	
Empty Operating Weight	kg (lb)	45 585 (100,497)	49 312 (108,714)	
Target Payload (100%)*	kg (lb)	57 155 (126,006)	53 428 (117,789)	
Target Payload Material Density	tonnes (tons)	57.2 (63.0)	53.4 (58.9)	
Maximum Payload (110% of Target)*	kg (lb)	57 155 (126,006)	53 428 (117,789)	
Maximum Payload Material Density	kg (lb)	62 871 (138,607)	58 771 (129,568)	
Not to Exceed Payload (120% of Target)*	kg (lb)	68 586 (151,207)	64 114 (141,347)	
Not to Exceed Payload Material Density	kg (lb)	114 171 (251,704)	113 426 (250,061)	

*Refer to Caterpillar 10/10/20 Payload Policy.

Sideboards (optional)

Height		Volume Add		Weight		Maximum (110%) Material Density**	
mm	(in)	m ³	(yd ³)	kg	(lb)	kg	(lb)
155	(6.0)	2.9	(3.8)	430	(948)	1681	(342)

**Based on Quarry Body at 90% Body Volume Fill.

Empty Chassis Weight is figured without fuel.

Payload Calculation: Definitions

Empty Machine Weight = Empty Chassis Weight + Body System Weight

Target Payload = Target Gross Machine Weight less Empty Machine Weight

Maximum Payload = Target Payload × 1.10 (110%)

773 Off-Highway Truck Specifications

10/10/20 Payload Management Policy for Optimal Machine Life

The ideal hauling strategy that maximizes machine and machine component life is to *keep the mean of all payloads at or below the machine's rated target payload.*

- 90% of loads should fall into this range
- No more than 10% of loads should exceed 10% of the target payload
- No loads should be above 20% of the target payload

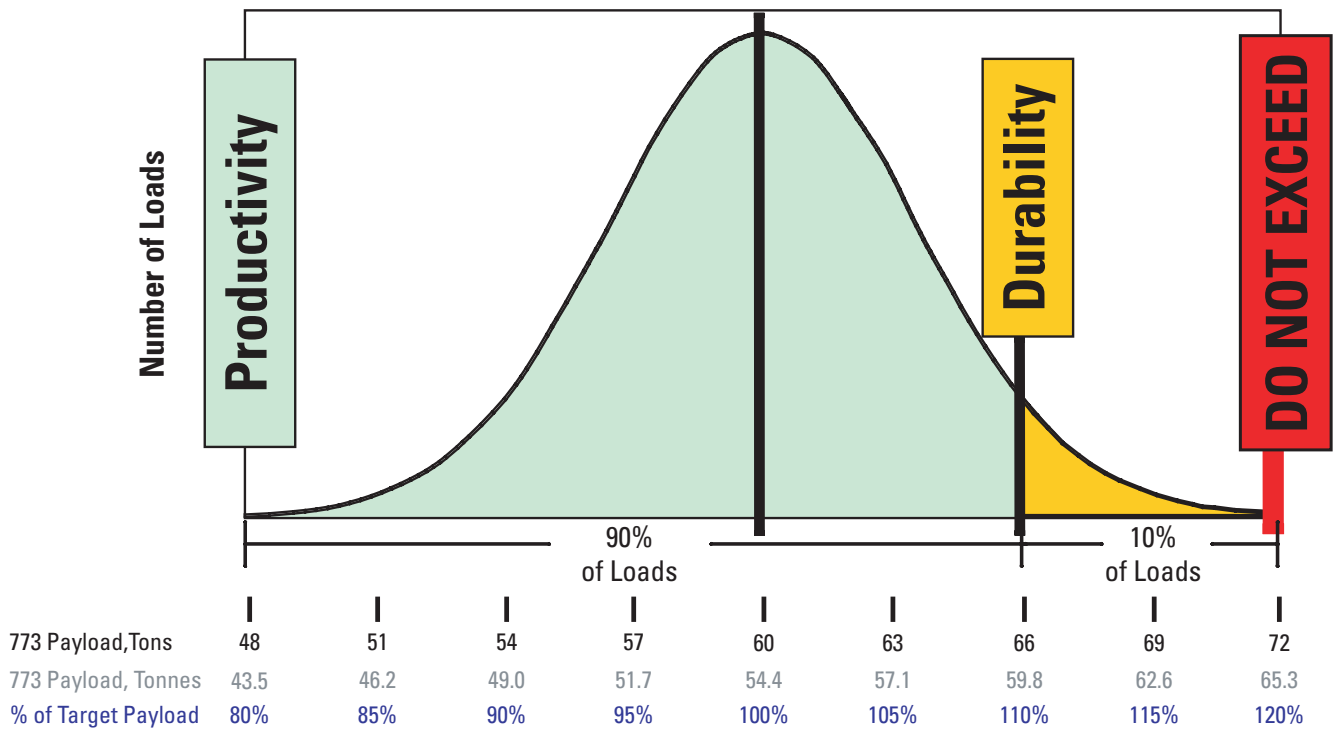

773 Off-Highway Truck Specifications

Dimensions

All dimensions are approximate.

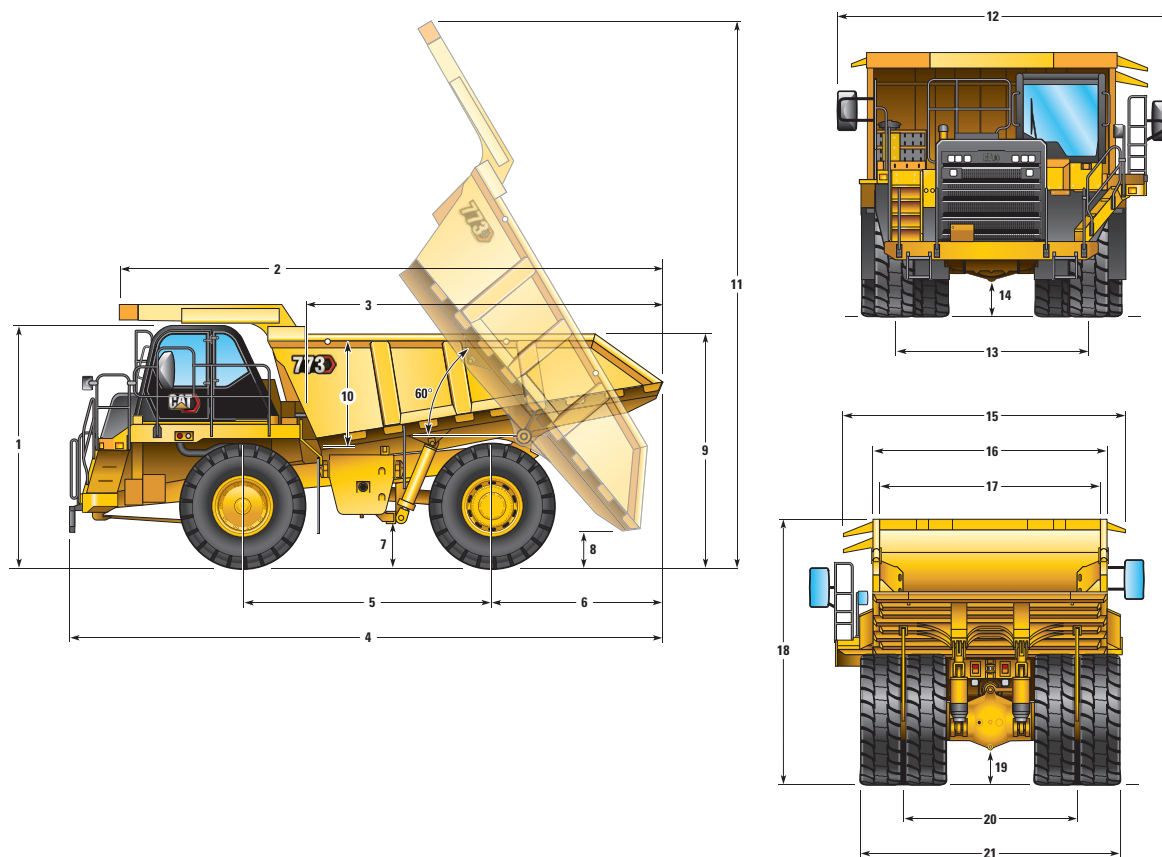

	Dual Slope		Flat Floor	
1 Height to Top of ROPS	4108 mm	13'6"	4108 mm	13'6"
2 Overall Body Length	9216 mm	30'3"	9293 mm	30'6"
3 Inside Body Length	6100 mm	20'0"	6100 mm	20'0"
4 Overall Length	10 070 mm	33'0"	10 146 mm	33'3"
5 Wheelbase	4215 mm	13'10"	4215 mm	13'10"
6 Rear Axle to Tail	2925 mm	9'7"	3006 mm	9'10"
7 Ground Clearance	759 mm	2'6"	759 mm	2'6"
8 Dump Clearance	639 mm	2'1"	640 mm	2'1"
9 Loading Height – Empty	3771 mm	12'4"	3771 mm	12'4"
10 Inside Body Depth – Maximum	1773 mm	5'10"	1727 mm	5'8"
11 Overall Height – Body Raised	9284 mm	30'6"	9280 mm	30'5"
12 Operating Width	5673 mm	18'7"	5673 mm	18'7"
13 Centerline Front Tire Width	3205 mm	10'6"	3205 mm	10'6"
14 Engine Guard Clearance	703 mm	2'4"	703 mm	2'4"
15 Overall Canopy Width	4886 mm	16'0"	4886 mm	16'0"
16 Outside Body Width	3922 mm	12'10"	3922 mm	12'10"
17 Inside Body Width	3654 mm	11'9"	3654 mm	11'9"
18 Front Canopy Height	4459 mm	14'8"	4459 mm	14'8"
19 Rear Axle Clearance	560 mm	1'10"	560 mm	1'10"
20 Centerline Rear Dual Tire Width	2929 mm	9'7"	2929 mm	9'7"
21 Overall Tire Width	4411 mm	14'6"	4411 mm	14'6"

773 Off-Highway Truck Specifications

Retarding Performance (Tier 4/Stage V)

To determine retarding performance: Add lengths of all downhill segments and, using this total, refer to proper retarding chart. Read from gross weight down to the percent effective grade. Effective grade equals actual % grade minus 1% for each 10 kg/t (20 lb/ton) of rolling resistance. From this weight-effective grade point, read horizontally to the curve with the highest obtainable gear, then down to maximum descent speed brakes can properly handle without exceeding cooling capacity. The following charts are based on these conditions: 32° C (90° F) ambient temperature, at sea level, with 24.00R35 (E4) tires.

NOTE: Select the proper gear to maintain engine rpm at the highest possible level, without overspeeding the engine. If cooling oil overheats, reduce ground speed to allow transmission to shift to the next lower speed range.

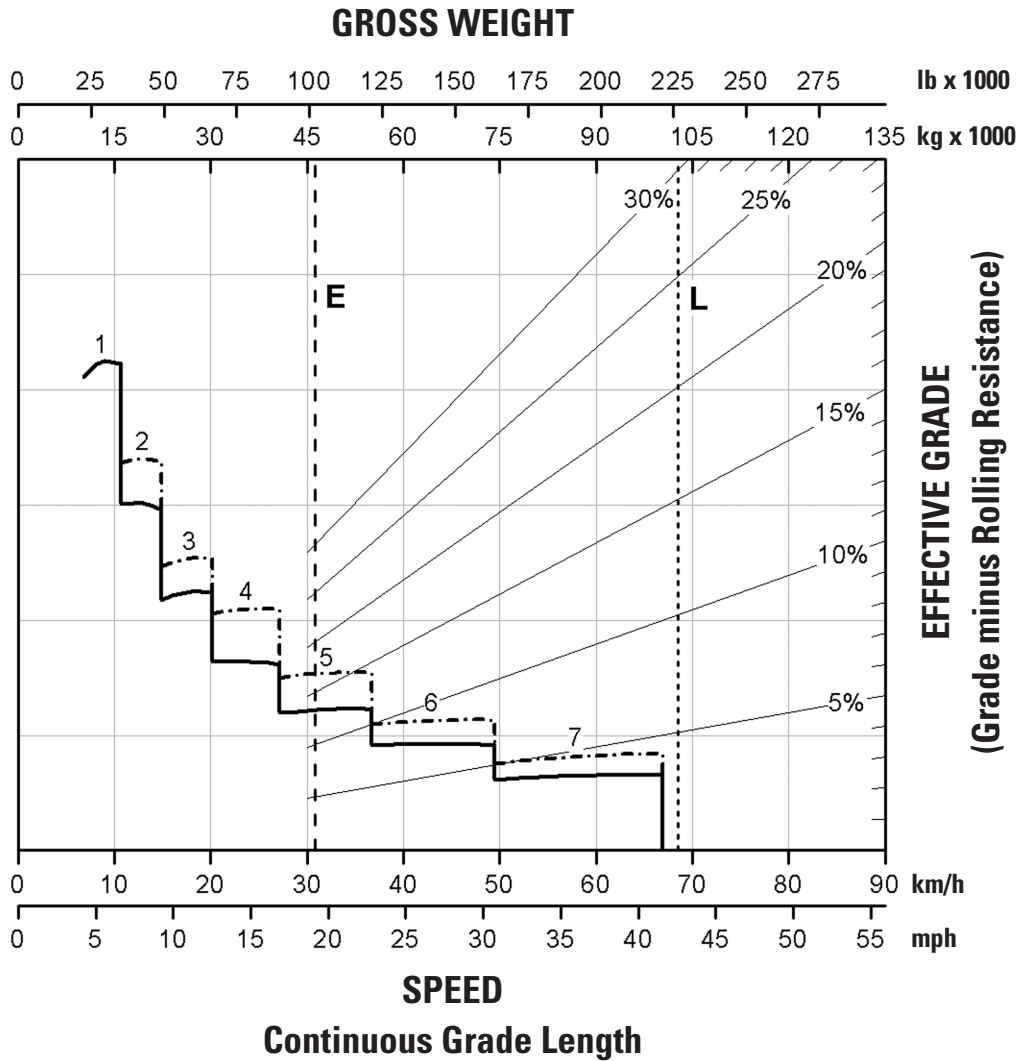

Retarding Performance (Tier 4/Stage V)

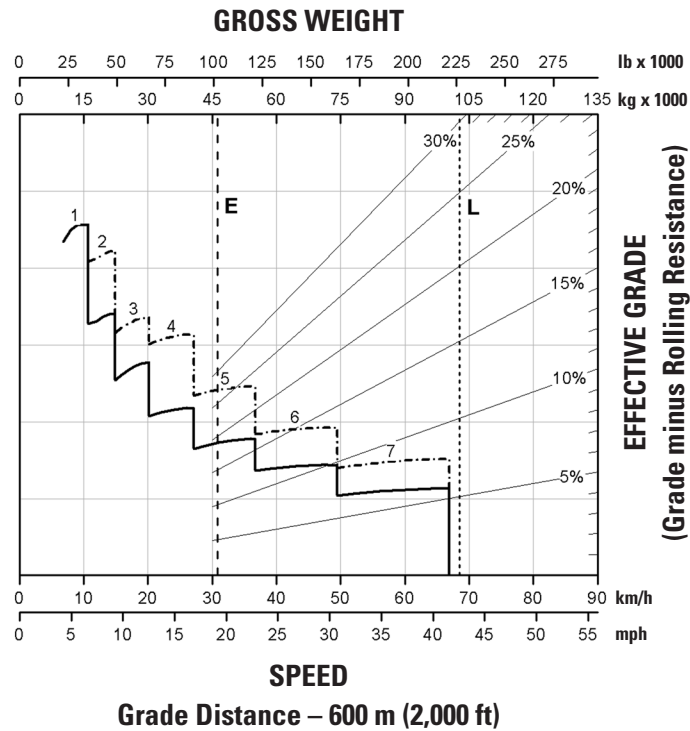
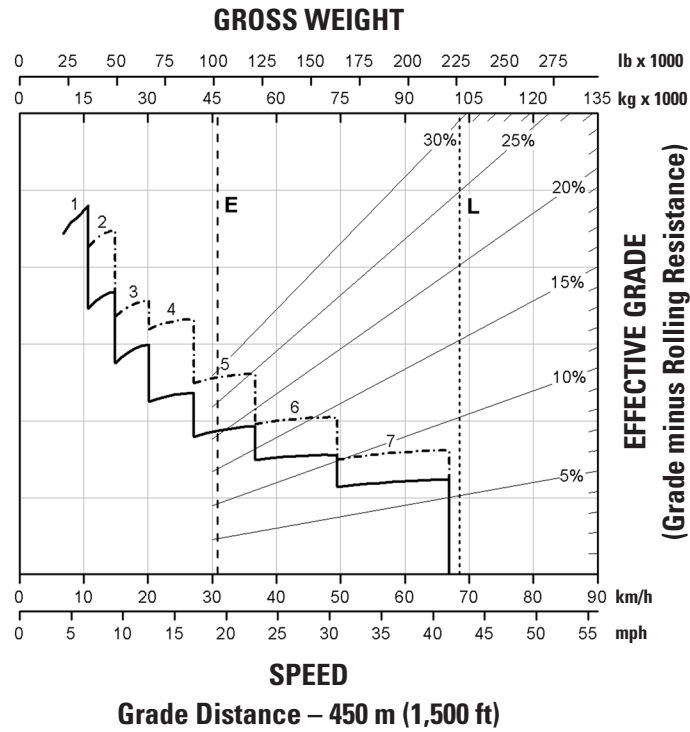

- with ARC only
- - - - - ARC and Engine Brake
- E – Typical Field Empty Weight
- L – Target Gross Machine Operating Weight 102 739 kg (226,500 lb)

773 Off-Highway Truck Specifications

Retarding Performance (Tier 4/Stage V)

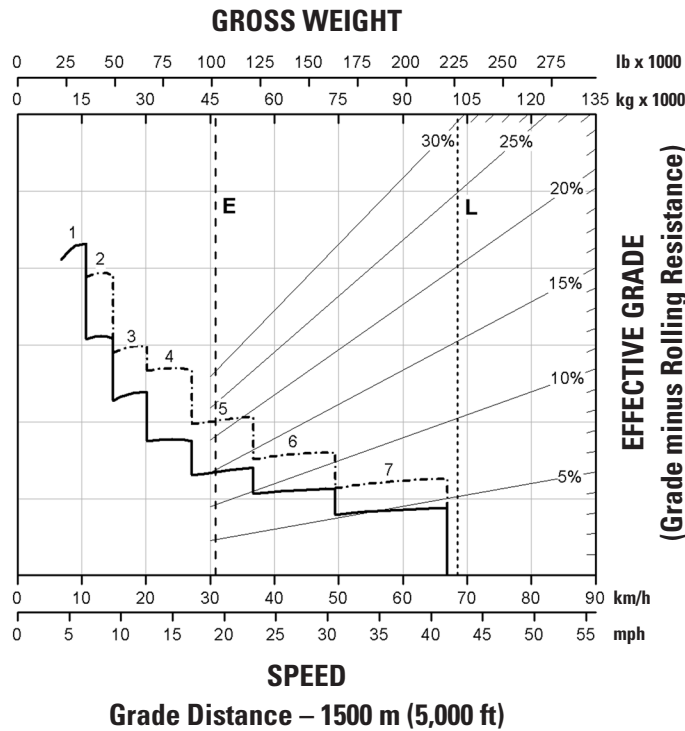
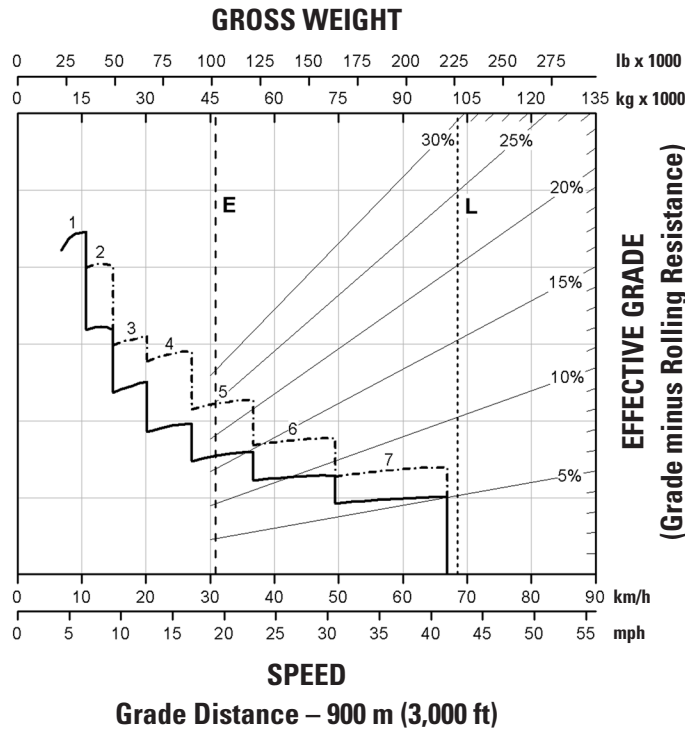

- with ARC only
- - - - - ARC and Engine Brake
- E – Typical Field Empty Weight
- L – Target Gross Machine Operating Weight 102 739 kg (226,500 lb)

773 Off-Highway Truck Specifications

Gradeability/Speed/Rimpull (Tier 4/Stage V)

To determine gradeability performance: Read from gross weight down to the percent of total resistance. Total resistance equals actual percent grade plus 1% for each 10 kg/t (20 lb/ton) of rolling resistance. From this weight-resistance point, read horizontally to the curve with the highest obtainable gear, then down to maximum speed. Usable rimpull will depend upon traction available and weight on drive wheels.

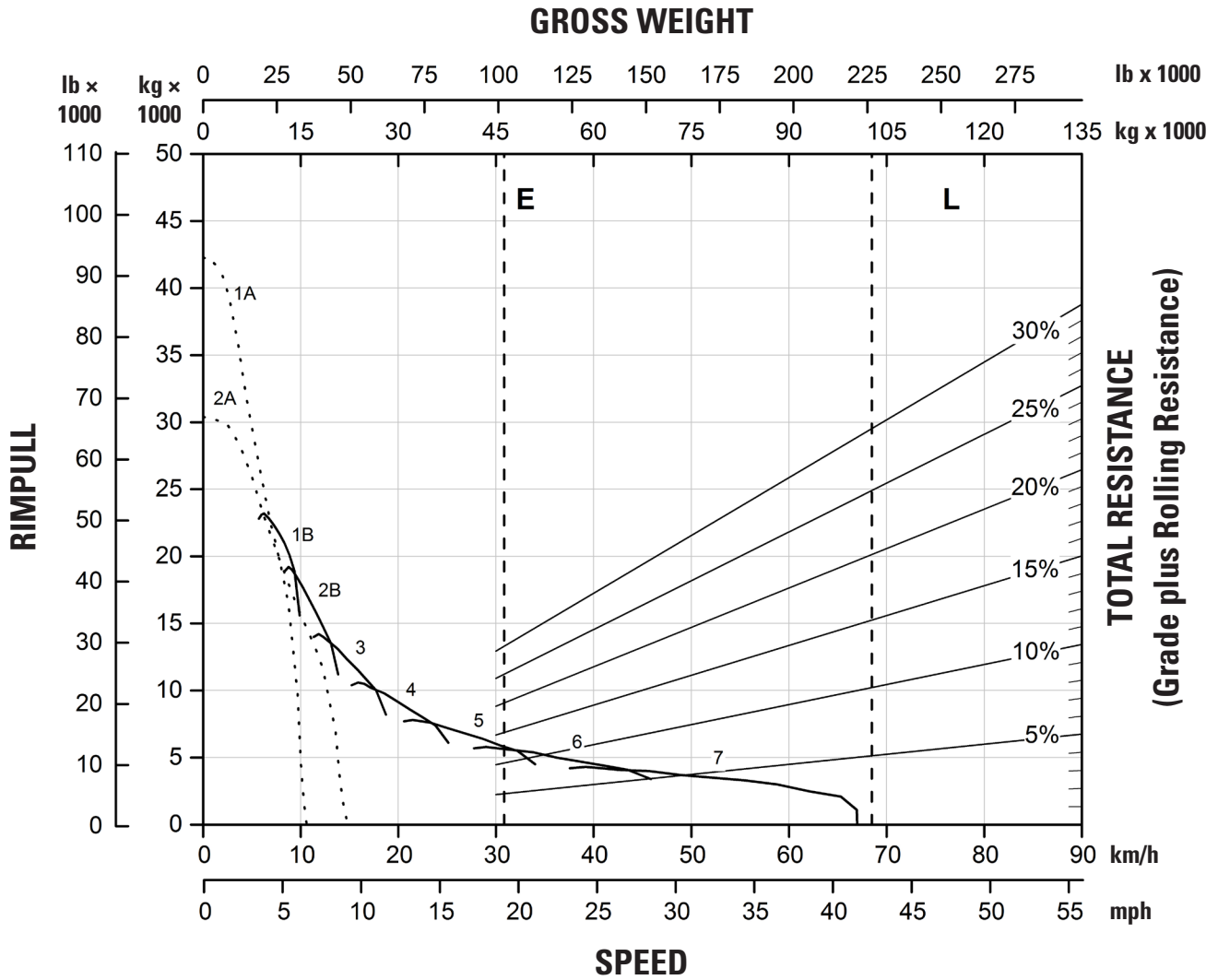

- with ARC only
- - - - - ARC and Engine Brake
- E** – Typical Field Empty Weight
- L** – Target Gross Machine Operating Weight 102 739 kg (226,500 lb)

773 Off-Highway Truck Specifications

Retarding Performance (Tier 2 Equivalent)

To determine retarding performance: Add lengths of all downhill segments and, using this total, refer to proper retarding chart. Read from gross weight down to the percent effective grade. Effective grade equals actual % grade minus 1% for each 10 kg/t (20 lb/ton) of rolling resistance. From this weight-effective grade point, read horizontally to the curve with the highest obtainable gear, then down to maximum descent speed brakes can properly handle without exceeding cooling capacity. The following charts are based on these conditions: 32° C (90° F) ambient temperature, at sea level, with 24.00R35 (E4) tires.

NOTE: Select the proper gear to maintain engine rpm at the highest possible level, without overspeeding the engine. If cooling oil overheats, reduce ground speed to allow transmission to shift to the next lower speed range.

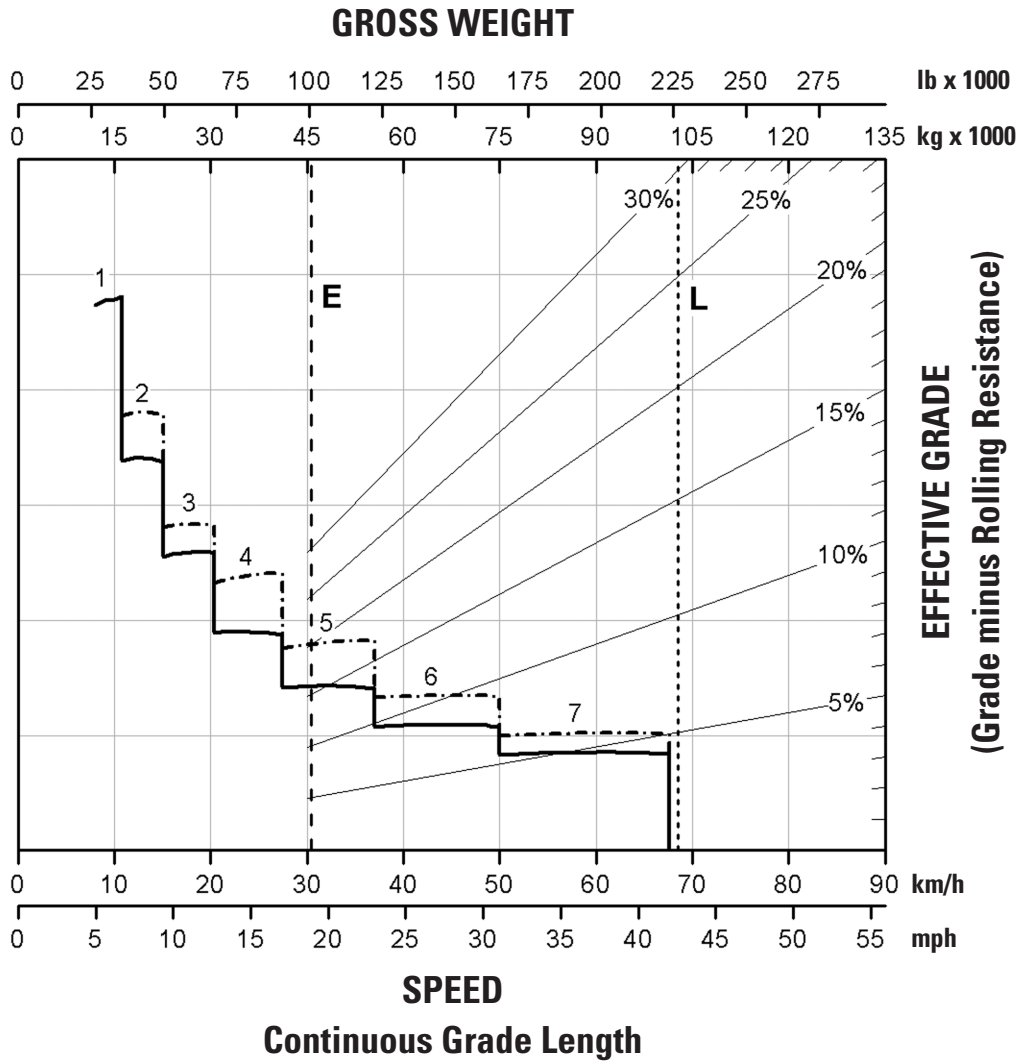

Retarding Performance (Tier 2 Equivalent)

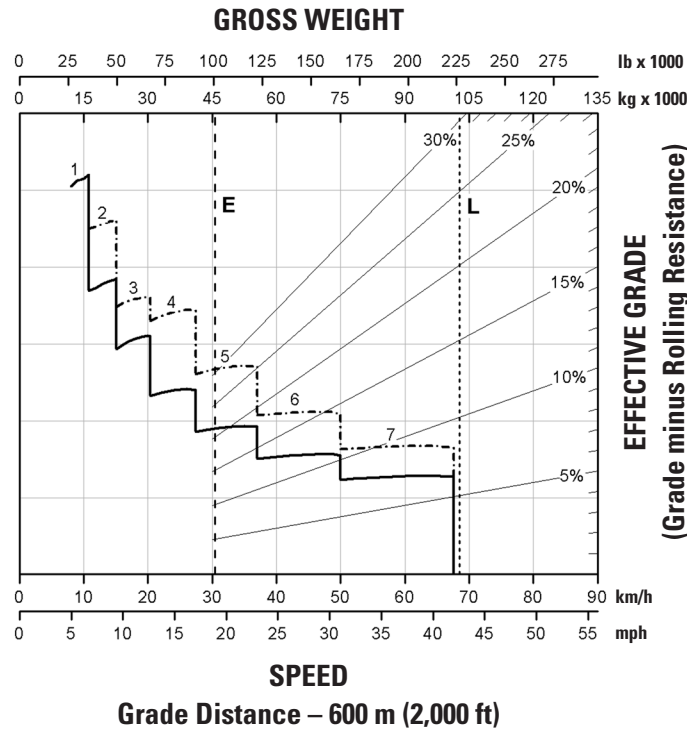
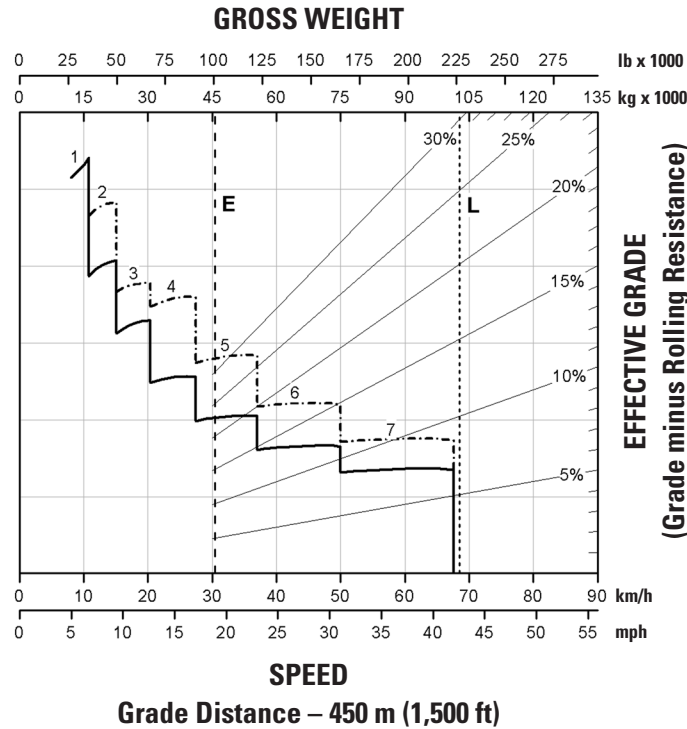

- with ARC only
- - - - ARC and Engine Brake
- E – Typical Field Empty Weight
- L – Target Gross Machine Operating Weight 102 739 kg (226,500 lb)

773 Off-Highway Truck Specifications

Retarding Performance (Tier 2 Equivalent)

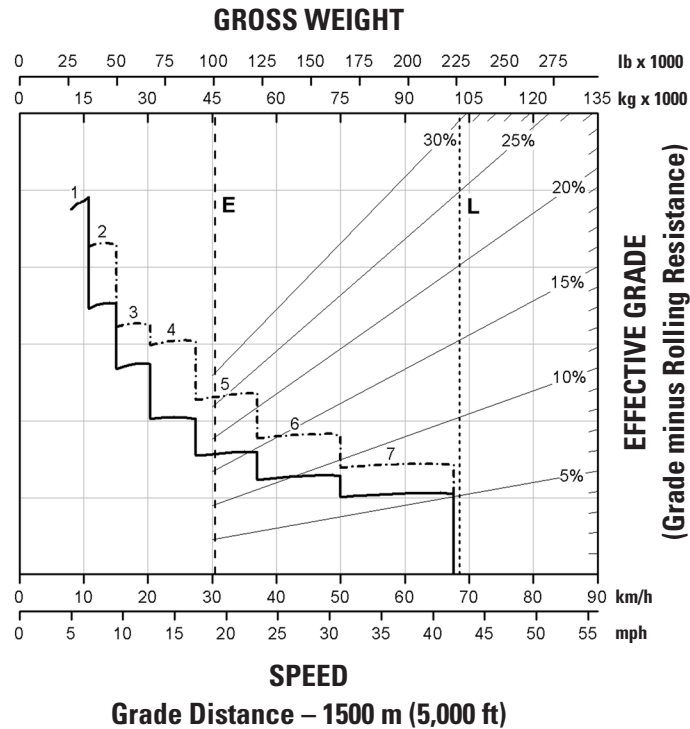
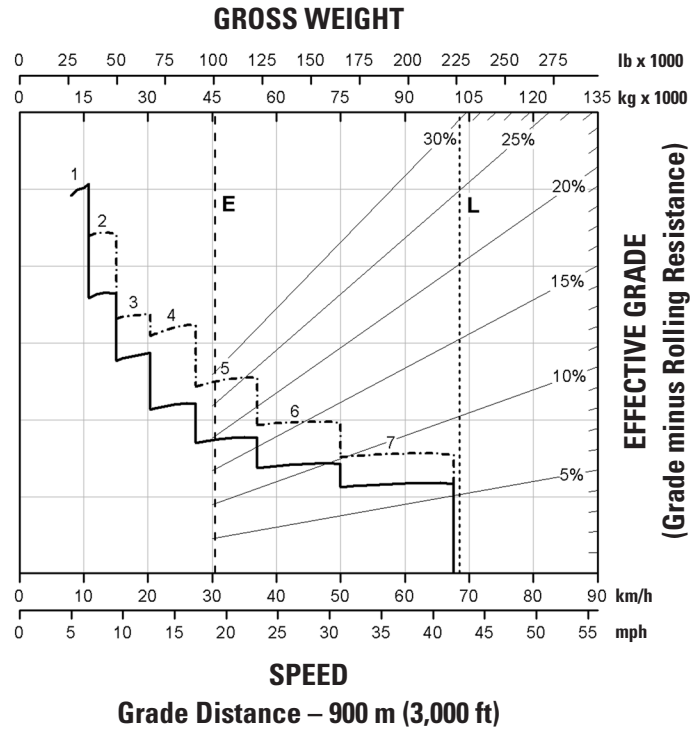

- with ARC only
- - - - - ARC and Engine Brake
- E – Typical Field Empty Weight
- L – Target Gross Machine Operating Weight 102 739 kg (226,500 lb)

Gradeability/Speed/Rimpull (Tier 2 Equivalent)

To determine gradeability performance: Read from gross weight down to the percent of total resistance. Total resistance equals actual percent grade plus 1% for each 10 kg/t (20 lb/ton) of rolling resistance. From this weight-resistance point, read horizontally to the curve with the highest obtainable gear, then down to maximum speed. Usable rimpull will depend upon traction available and weight on drive wheels.

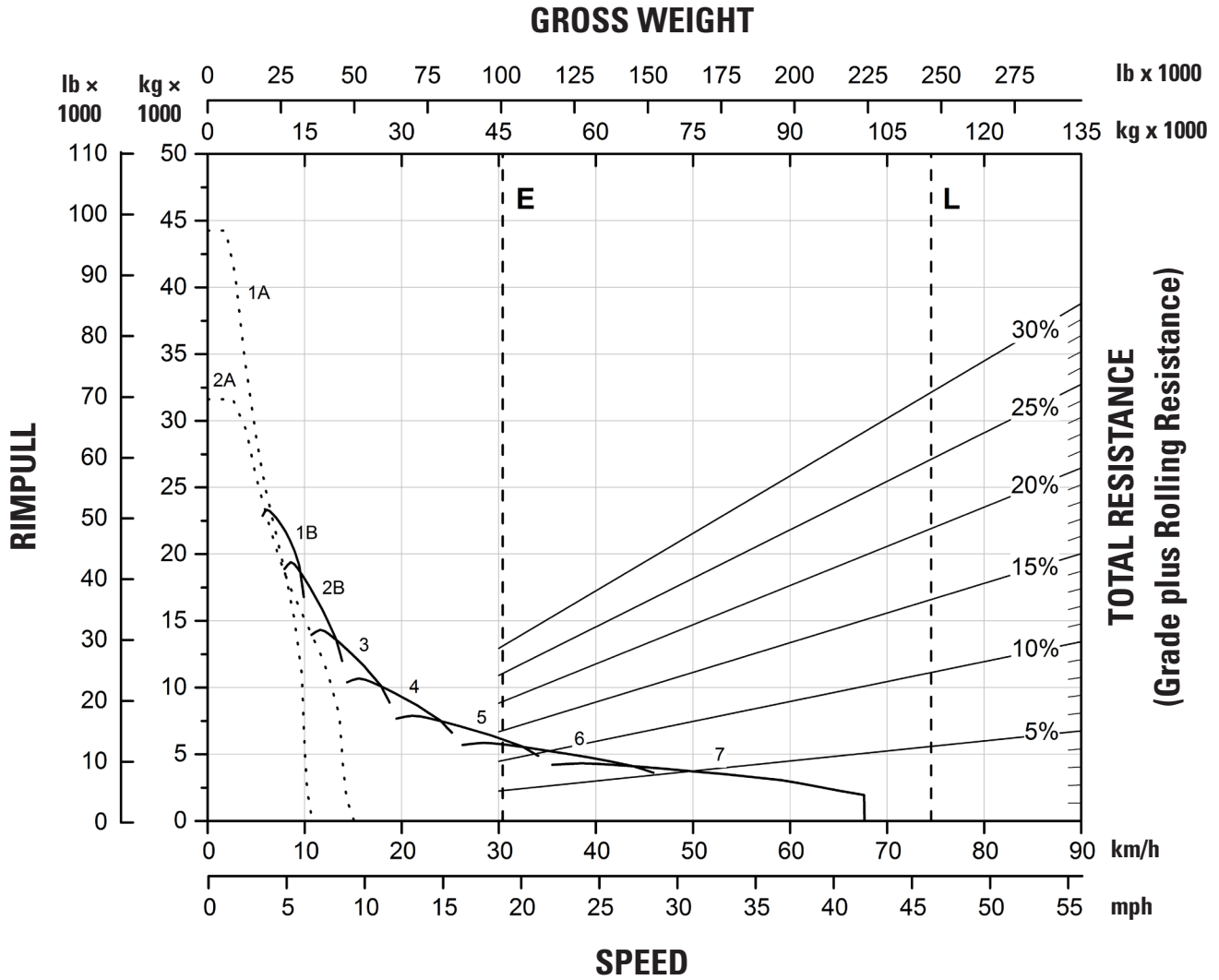

- with ARC only
- ARC and Engine Brake
- E – Typical Field Empty Weight
- L – Target Gross Machine Operating Weight 102 739 kg (226,500 lb)

773 Off-Highway Truck Specifications

Standard and Optional Equipment

Standard and optional equipment may vary. Consult your Cat dealer for details.

	Standard	Optional		Standard	Optional
POWERTRAIN			OPERATOR ENVIRONMENT (CONTINUED)		
C27 U.S. EPA Tier 4 Final/EU Stage V or U.S. EPA Tier 2 equivalent diesel engine: air cleaner with precleaner (2), air-to-air aftercooler (ATAAC), electric start, engine idle shutdown, ether starting aid, exhaust muffler, next generation modular radiator (NGMR)	✓		Cab precleaner		✓
Braking system: extended life brakes, automatic retarder control (ARC), manual retarder (utilizes rear oil-cooled, multiple disc brakes), brake release motor (towing), dry disc brakes (front), brake disconnect switch (front), oil-cooled multiple disc brakes (rear), brake wear indicator (rear), parking brake, secondary brake, service brake	✓		Coat hook	✓	
Cat® engine brake		✓	Cup holders (4)	✓	
NO _x reduction system (NRS), diesel oxidation catalyst (DOC); demand fan; Mechanically Actuated Electronic Unit Injection (MEUI™) -C fuel system (Tier 4 Final/Stage V only)	✓		Diagnostic connection port, 24V	✓	
Transmission: 7-speed automatic powershift with electronic clutch pressure control (ECPC), advanced productivity electronic control strategy (APECS); automatic neutral idle, autostall, second gear start	✓		Entertainment radio ready: 5 amp converter, speakers, antenna, wiring harness	✓	
ELECTRICAL			Foot rest	✓	
Alarm, backup	✓		Gauges/indicators: brake oil temperature gauge, coolant temperature gauge, engine overspeed indicator, fuel level, hour meter, speedometer with odometer, tachometer, transmission gear indicator	✓	
Alternator, 120 ampere	✓		Hoist lever	✓	
Autolube power supply ready	✓		Horn	✓	
Batteries, maintenance-free, 12V (2), 1,400 CCA combined	✓		Light: courtesy, dome	✓	
Electrical system, 25 amp, 24V to 12V converter	✓		Lights – high intensity discharge (HID)		✓
Lighting system: backup light (halogen), directional signals/hazard warning (front and rear LED), engine compartment light, headlights (halogen) with dimmer, operator access courtesy lights, side profile lights, stop/tail lights (LED)	✓		Mirrors: convex, heated		✓
Service center containing: battery jump start, breakers with spare fuses, lockout switch, ports – electronic technician (ET) and advanced health, service lockout switch (power without engine start)	✓		Mirrors, non-heated	✓	
OPERATOR ENVIRONMENT			Power port, 24V and 12V (2)	✓	
Advisor display: air cleaner service indicator, fluid level monitoring, fuel level monitoring, display languages (market based)	✓		Rollover protective structure (ROPS)/falling objects protective structure (FOPS)	✓	
Air conditioning/heat	✓		Seat, Cat Comfort Series III: full air suspension, retractable 3-point seat belt with shoulder harness	✓	
Ashtray and cigarette lighter	✓		Seat, training with lap belt	✓	
Automatic temperature control	✓		Steering wheel, padded, tilt and telescopic	✓	
			Storage compartment	✓	
			Sun visor	✓	
			Throttle lock	✓	
			Visibility package (meets ISO 5006:2017 requirements)		✓
			Window, hinged, right side (emergency exit)	✓	
			Window, powered, left side	✓	
			Windshield wiper, intermittent, and washer	✓	
			Work area vision system (WAVS)		✓
			TECHNOLOGY PRODUCTS		
			Economy modes, standard and adaptive	✓	
			Product Link™, cellular or satellite	✓	
			Traction control system (TCS)	✓	
			Truck production management system	✓	
			Advanced health	✓	

Standard and Optional Equipment

Standard and optional equipment may vary. Consult your Cat dealer for details.

OTHER

Antifreeze	✓
Body heat	✓
Body liner	✓
Body sideboards	✓
Body down indicator	✓
Body safety pin (secures body in up position)	✓
Center-mounted rims	✓
Clustered grease fittings	✓
Cold weather packages	✓
Driveline guards	✓
Engine crankcase guards	✓
Extended life coolant to -34°C (-30°F)	✓
Fan guards	✓
Fluid fill service center	✓
Fuel tank, 795 L (210 gal)	✓
Ground-level battery disconnect	✓

OTHER (CONTINUED)

Ground-level engine shutdown	✓
Ground-level grease fittings	✓
Grouped ground-level filters	✓
Operator maintenance manual (OMM)	✓
Rims 17 × 35	✓
Rock ejectors	✓
Secondary steering (electric)	✓
Spare rim	✓
Suspension, front and rear (EU compliant)	✓
Tie down eyes	✓
Tow hooks, front/tow pin, rear	✓
Wheel chocks	✓
Vandalism protection locks	✓

773 Environmental Declaration

The following information applies to the machine at the time of final manufacture as configured for sale in the regions covered in this document. The content of this declaration is valid as of the date issued; however, content related to machine features and specifications are subject to change without notice. For additional information, please see the machine's Operation and Maintenance Manual.

For more information on sustainability in action and our progress, please visit <https://www.caterpillar.com/en/company/sustainability>.

C Engine

- The Cat® C27 engine is available in configurations that meet U.S. EPA Tier 4 Final and EU Stage V emission standards or equivalent to U.S. EPA Tier 2.
- Cat U.S. EPA Tier 4 Final and EU Stage V diesel engines are required to use ULSD (ultra-low sulfur diesel fuel with 15 ppm of sulfur or less) or ULSD blended with the following lower-carbon intensity fuels*** up to:
 - ✓ 20% biodiesel FAME (fatty acid methyl ester)*
 - ✓ 100% renewable diesel, HVO (hydrogenated vegetable oil) and GTL (gas-to-liquid) fuels
- Cat engines equivalent to U.S. EPA Tier 2 are compatible with diesel fuel blended with the following lower-carbon intensity fuels*** up to:
 - ✓ 100% biodiesel FAME (fatty acid methyl ester)**
 - ✓ 100% renewable diesel, HVO (hydrogenated vegetable oil) and GTL (gas-to-liquid) fuels

Refer to guidelines for successful application. Please consult your Cat dealer or "Caterpillar Machine Fluids Recommendations" (SEBU6250) for details.

**Engines with no aftertreatment devices can use higher blends, up to 100% biodiesel.*

***For use of blends higher than 20% biodiesel, consult your Cat dealer.*

****Tailpipe greenhouse gas emissions from lower-carbon intensity fuels are essentially the same as traditional fuels.*

Air Conditioning System

- The air conditioning system on this machine contains the fluorinated greenhouse gas refrigerant R134a (Global Warming Potential = 1430). The system contains 2.0 kg (4.4 lb) of refrigerant which has a CO₂ equivalent of 2.860 metric tonnes (3.152 tons).

Paint

- Based on best available knowledge, the maximum allowable concentration, measured in parts per million (PPM), of the following heavy metals in paint are:
 - Barium < 0.01%
 - Cadmium < 0.01%
 - Chromium < 0.01%
 - Lead < 0.01%

Sound Performance

- The operator Equivalent Sound Pressure Level (Leq) is 76 dB(A) when SAE J1166 FEB2008 is used to measure the value for an enclosed cab. This is a work cycle sound exposure level. The cab was properly installed and maintained. The test was conducted with the cab doors and the cab windows closed.
- The exterior sound pressure level for the standard machine measured at a distance of 15 m (49 ft) according to the test procedures specified in SAE J88:2008, mid-gear moving operation is 86 dB(A).
- Hearing protection may be needed when operating with an open operator station and cab (when not properly maintained or doors/windows open) for extended periods or in a noisy environment.

Oils and Fluids

- Caterpillar factory fills with ethylene glycol coolants. Cat Diesel Engine Antifreeze/Coolant (DEAC) and Cat Extended Life Coolant (ELC) can be recycled. Consult your Cat dealer for more information.
- Cat Bio HYDO Advanced is an EU Ecolabel approved biodegradable hydraulic oil.
- Additional fluids are likely to be present, please consult the Operations and Maintenance Manual or the Application and Installation guide for complete fluid recommendations and maintenance intervals.

Features and Technology

- The following features and technology may contribute to fuel savings and/or carbon reduction. Features may vary. Consult your Cat dealer for details.
 - Automatically optimize fuel consumption with two fuel economy modes: standard and adaptive
 - Adjustable engine idle shutdown conserves fuel when the truck is in park and idle for a preset amount of time
 - Haul at a more fuel-efficient engine speed and gear selection with speed limiting
 - Traction control system modulates power and braking between the two wheel groups, allowing a more appropriate response to ground conditions
 - Longer service life for hydraulic oil filter provides longer life with a 1,000-hour replacement interval

Recycling

- The materials included in machines are categorized as below with approximate weight percentage. Because of variations of product configurations, the following values in the table may vary.

Material Type	Weight Percentage
Steel	64.74%
Iron	14.03%
Nonferrous Metal	2.32%
Mixed Metal	0.36%
Plastic	2.89%
Rubber	10.78%
Mixed Nonmetallic	0.05%
Fluid	2.81%
Other	1.31%
Uncategorized	0.72%
Total	100%

- A machine with higher recyclability rate will ensure more efficient usage of valuable natural resources and enhance end-of-life value of the product. According to ISO 16714 (Earthmoving machinery – Recyclability and recoverability – Terminology and calculation method), recyclability rate is defined as percentage by mass (mass fraction in percent) of the new machine potentially able to be recycled, reused, or both.

All parts in the bill of material are first evaluated by component type based on a list of components defined by the ISO 16714 and Japan CEMA (Construction Equipment Manufacturers Association) standards. Remaining parts are further evaluated for recyclability based on material type.

Because of variations of product configurations, the following value in the table may vary.

Recyclability – 95%

For more complete information on Cat products, dealer services, and industry solutions, visit us on the web at www.cat.com.

Materials and specifications are subject to change without notice. Featured machines in photos may include additional equipment. See your Cat dealer for available options.

© 2023 Caterpillar. All Rights Reserved. CAT, CATERPILLAR, LET'S DO THE WORK, their respective logos, MEUI, Product Link, "Caterpillar Corporate Yellow", the "Power Edge" and Cat "Modern Hex" trade dress as well as corporate and product identity used herein, are trademarks of Caterpillar and may not be used without permission.

AEXQ3436-00 (11-2023)
Build Number: 07
(Global)

