

# E44 Turbo Aftercooled

Marine Auxiliary Engine

Inland Waterways EU Stage V/EPA T3/ CHINA II  
Prime Power 81.5-129 kWm @ 1500/1800 rpm

*The Perkins E44 is a turbocharged, charge air-cooled, four cylinder, 4.4 litre engine, one of a family of engines to meet Inland Waterways EU Stage V, U.S. EPA Tier 3 Final and China II emission standards.*

*Competitive engine and parts pricing, extended service intervals and exceptionally low fuel consumption make the E44 a cost effective choice with significant owner savings over alternative engines.*

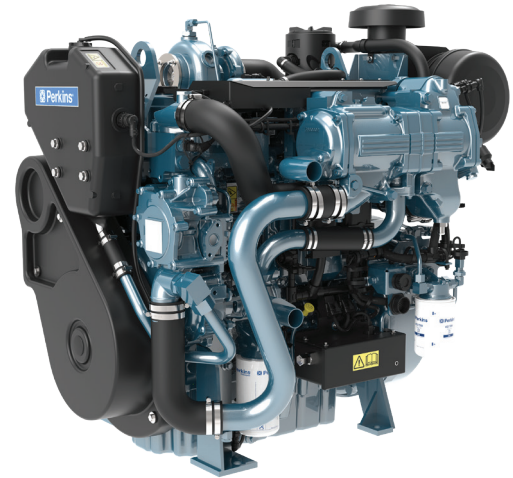

## Features and benefits

### Lower Operating Costs

Service intervals 500 hours as standard and Perkins provides comprehensive warranty cover for 2 years, with 3 years on major engine components.

### Powered By Your Needs

Perkins engines can be tailored specifically for you.

These engines offer a choice of standard build configurations to match the needs of customers for a diverse range of applications.

### World Class Product Support

With over 80 years experience, we are experts in the engines industry. At Perkins we are constantly researching, developing and investing in our products and services. Strong global support is provided through a network of over 130 distributors and service outlets in 184 countries, providing access to over 50,000 parts and exchange units 24 hours a day, 365 days a year.

Specification	
Cylinders	4
Displacement, litres (in <sup>3</sup> )	4.4 (268)
Aspiration	Turbocharged/Aftercooled
Bore and stroke, mm	105 × 127
Maximum power, kW (hp)	81.5 (109)- 129 (173)
Rated speed, rpm	1500 - 1800
Maximum torque, Nm (lb ft) @ rpm	691 (510) - 432 (319) @ 1500 / 1800
Combustion system	Direct injection
Rotation (viewed from flywheel)	Anti-clockwise

For more information please contact a Perkins distributor: <http://distributorlocator.perkins.com>

All information in this document is substantially correct at time of printing and may be altered subsequently. Photographs are for illustrative purposes only and may not reflect final specification. Final weight and dimensions will depend on completed specification. Information subject to selected configuration, and subject to change without notice. Engine power measured per ISO 14396, 3046/1 standard reference conditions. Ref: 6473970 Issue 3. Produced in England ©2024 Perkins Marine.



# E44 Turbo Aftercooled

Marine Auxiliary Engine

Inland Waterways EU Stage V/EPA T3/ CHINA II

Prime Power 81.5-129 kW @ 1500/1800 rpm

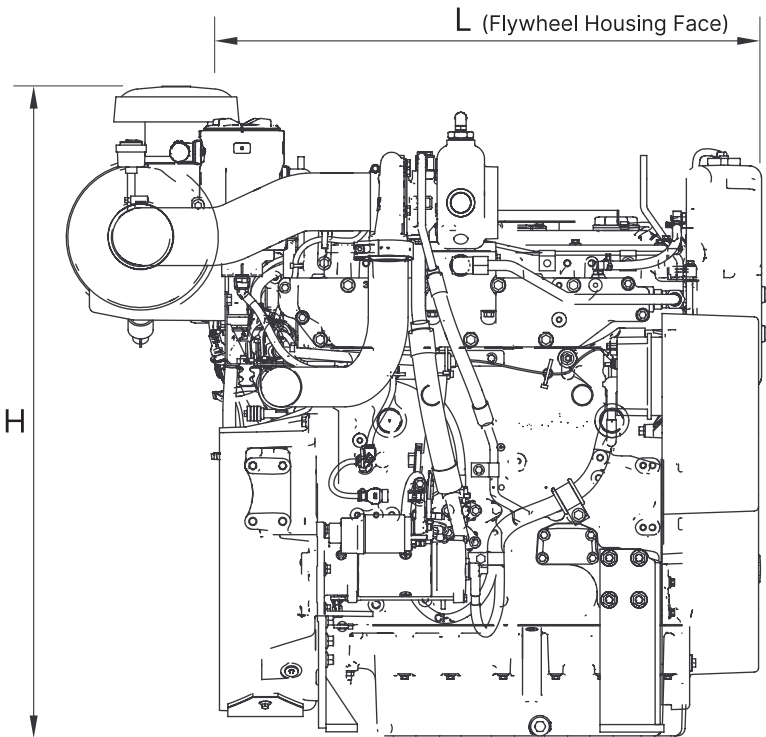
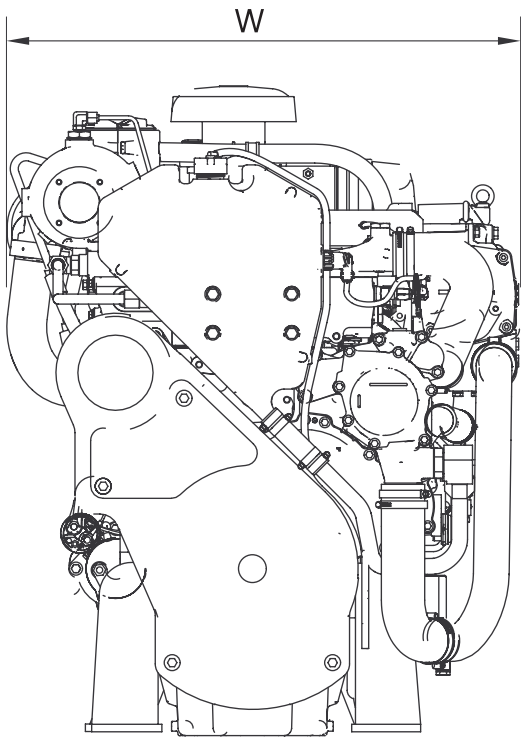
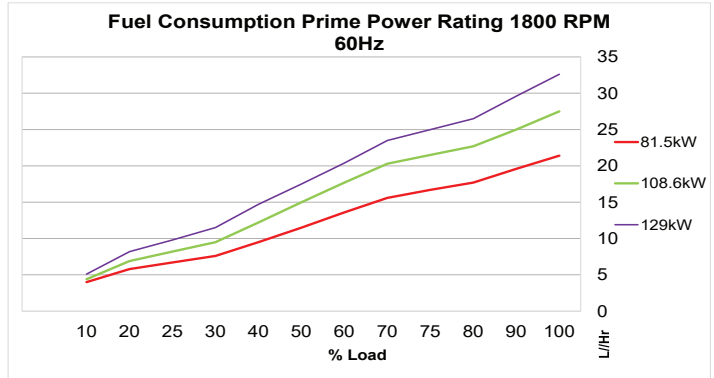
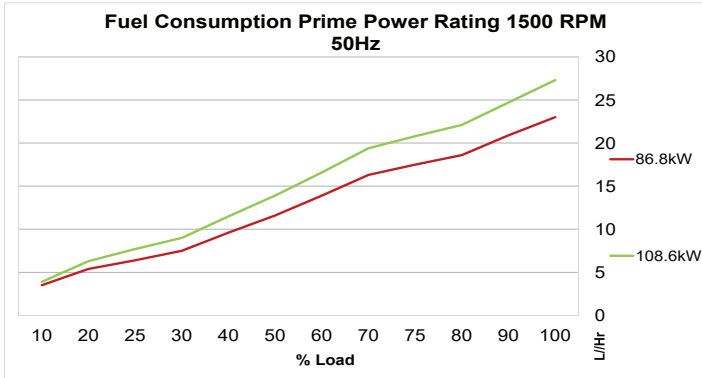

Dimensions and weight	
Width, mm	814
Height, mm	1038
Length, mm	856
Weight, kg (lb)	579 (1276) wet

For more information please contact a Perkins distributor: <http://distributorlocator.perkins.com>

All information in this document is substantially correct at time of printing and may be altered subsequently. Photographs are for illustrative purposes only and may not reflect final specification. Final weight and dimensions will depend on completed specification. Information subject to selected configuration, and subject to change without notice. Engine power measured per ISO 14396, 3046/1 standard reference conditions. Ref: 6473970 Issue 3. Produced in England ©2024 Perkins Marine.

