

E70B Turbo Aftercooled Fixed Speed

Marine Auxiliary Engine

*IMO 2/ EPA T3 / CHINA II

109-216 kWm @ 1800 rpm

*E70B Fixed Speed ratings above 130kWm Prime certified to IMO II and not EUV.
Ratings below 130kWm Prime are not subject to IMO II but are EUV certified.

The Perkins E70B is a turbocharged, charge air-cooled, six cylinder, 7.01 litre engine, one of a family of engines to meet IMO 2, CHINA II and U.S. EPA Tier 3 emission standards.

Competitive engine and parts pricing, extended service intervals and exceptionally low fuel consumption make the E70B a cost effective choice with significant owner savings over alternative engines.

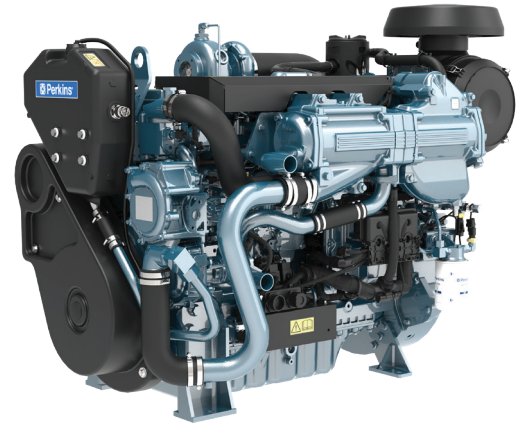

Features and benefits

Lower Operating Costs

Service intervals 500 hours as standard and Perkins provides comprehensive warranty cover for 2 years, with 3 years on major engine components.

Powered By Your Needs

Perkins engines can be tailored specifically for you.

These engines offer a choice of standard build configurations to match the needs of customers for a diverse range of applications.

World Class Product Support

With over 80 years experience, we are experts in the engines industry. At Perkins we are constantly researching, developing and investing in our products and services. Strong global support is provided through a network of over 130 distributors and service outlets in 184 countries, providing access to over 50,000 parts and exchange units 24 hours a day, 365 days a year.

Specification	
Cylinders	6
Displacement, litres (in ³)	7.01 (428)
Aspiration	Turbocharged / Aftercooled
Bore and stroke, mm	105 × 135
Maximum power, kW (hp)	218 - 109 (293 - 147) 1500 / 1800
Rated speed, rpm	1500 / 1800
Maximum torque, Nm (lb ft) @ rpm	1160 - 684 (855 - 505) @ 1500 / 1800
Combustion system	Direct injection
Rotation (viewed from flywheel)	Anti-clockwise

For more information please contact a Perkins distributor: <http://distributorlocator.perkins.com>

All information in this document is substantially correct at time of printing and may be altered subsequently.
Photographs are for illustrative purposes only and may not reflect final specification.
Final weight and dimensions will depend on completed specification.
Information subject to selected configuration, and subject to change without notice.
Engine power measured per ISO 14396, 3046/1 standard reference conditions.
Ref: 6473975 Issue 3. Produced in England ©2024 Perkins Marine.

E70B Turbo Aftercooled Fixed Speed

Marine Auxiliary Engine

*IMO 2/ EPA T3 / CHINA II

109-216 kWm @ 1800 rpm

*E70B Fixed Speed ratings above 130kWm Prime certified to IMO II and not EUV.
Ratings below 130kWm Prime are not subject to IMO II but are EUV certified.

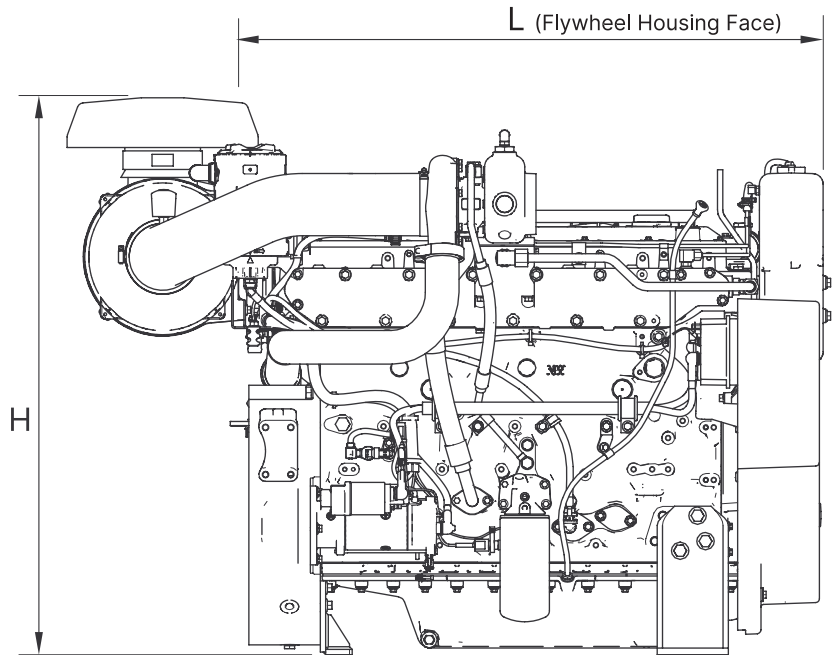
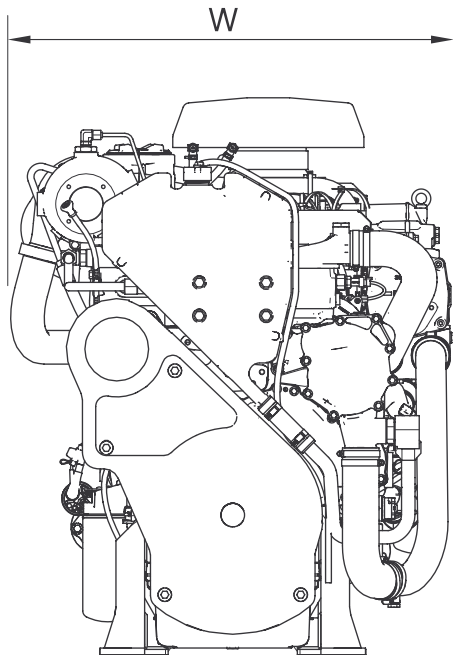
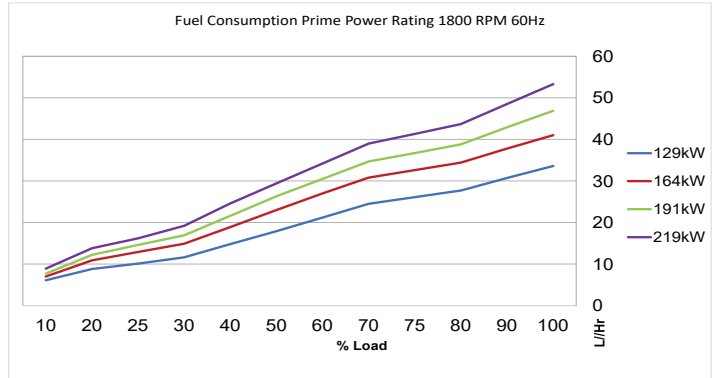
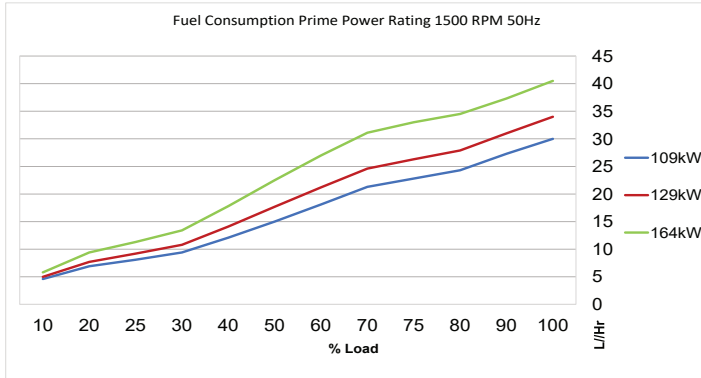

Dimensions and weight	
Width, mm	836
Height, mm	1132
Length, mm	1368
Weight, kg (lb)	759 (1673) wet

For more information please contact a Perkins distributor: <http://distributorlocator.perkins.com>

All information in this document is substantially correct at time of printing and may be altered subsequently. Photographs are for illustrative purposes only and may not reflect final specification. Final weight and dimensions will depend on completed specification. Information subject to selected configuration, and subject to change without notice. Engine power measured per ISO 14396, 3046/1 standard reference conditions. Ref: 6473975 Issue 3. Produced in England ©2024 Perkins Marine.

