



CAT[®] SDX SCREED PLATE SYSTEM

DESIGNED TO INCREASE DENSITY AND SMOOTHNESS

» DYNAMIC COMPACTION TECHNOLOGY



INFLUENCE THE OUTCOME

IMPROVE ROAD QUALITY WITH BETTER CONSISTENCY AND HIGHER RELIABILITY

Project planning, base preparation, mix design, reliable equipment, and proper paving techniques are keys to producing quality pavements. Ideal placement of the asphalt and reaching target densities are also extremely important factors that help pavements last longer.

Compacting asphalt at its highest temperature helps maximize density and deliver smoother results. In doing so, air void reduction must occur through manipulation and

compaction techniques to ensure that targeted results are being met.

Since the inception of the asphalt paver, screed plates have been manufactured with a flat surface. However, a recent design utilizes a three-dimensional angular plate. This innovative design provides dynamic flow through the screed plate in order to reduce air voids and increase density behind the screed.

» HOW THEY WORK

The Cat® SDX screed plate design consists of a three-dimensional angular surface on the front of the plates with a tapering smooth surface near the back. A kneading action occurs as the plates manipulate the mix as it passes through the angular channels. This unique innovation is designed to enhance the structural integrity of the asphalt, lessen compactor shoving, strengthen unconfined edges, and promote better surface temperature uniformity.

In addition to the angular plates, the system utilizes a revolutionary new fastening design that consists of an

adaptor plate that retains the heating elements and attaches to the screed frame. The screed plates are equipped with integrated tapered blocks that fit over the front and rear of the adaptor plates. High-temperature silicone locking bands apply tension to the plates to keep them in position for excellent reliability and performance. This unique design reduces standard hardware and lessens screed plate replacement time to as little as 4 hours.



» ENHANCED MAT QUALITY, INCREASED UPTIME

Increased Density and Smoothness

- Kinetic mixing action creates consistency across the width of the mat to help lower standard deviations between density readings and help meet Percent Within Limits (PWL) specifications
- Increased mat stiffness leads to less compactor shoving and promotes better smoothness
- The textured plate design promotes increased mat density and stiff edge profiles for improved joint matching capability

Advanced Screed Plate Design

- Cat SDX Screed Plates are designed with cast chromium-alloy materials for consistent properties throughout the plates that help increase wear life when compared to standard screed plate designs
- The modular 100 mm (4") and 300 mm (12") plate designs simplify handling, transport, and installation
- The 100 mm (4") center plates enable cross-slope and crown that provides versatility for a variety of application profiles

Innovative Fastening System

- The hardware-free locking system enables replacement in as little as 4 hours after the initial adaptor plate installation
- The unique screed plate locking system is designed to eliminate hardware and simplify removal and installation procedures
- Scheduled downtime for screed plate replacement is minimized with the simplified design



» SYSTEM COMPONENTS

Innovative Cat® SDX Screed Plate System utilizes an aluminum adaptor plate with beveled edges that retains the heating element and supports the screed plates. A unique screed plate locking system eliminates hardware for simplified removal and installation.



Adaptor Plate

- Utilizes existing structural design for easy retrofit from standard screed plates
- Heating elements are retained by the aluminum adaptor plates
- Screed plate leveling and angle of attack adjustment occurs on the adaptor plates



Cat SDX Screed Plates

- Main and extender sections are comprised of multiple plates that simplify installation
- Cast plates made of high strength chromium alloy materials provide durability
- Plates run flatter, providing extended wear qualities



Fastening System

- Eliminates hardware for faster screed plate replacement
- Tapered blocks integrated into the screed plates fit over the beveled edge of the adaptor plates
- High-temperature silicone retainers maintain tension for reliable performance

» PARTS BREAKDOWN

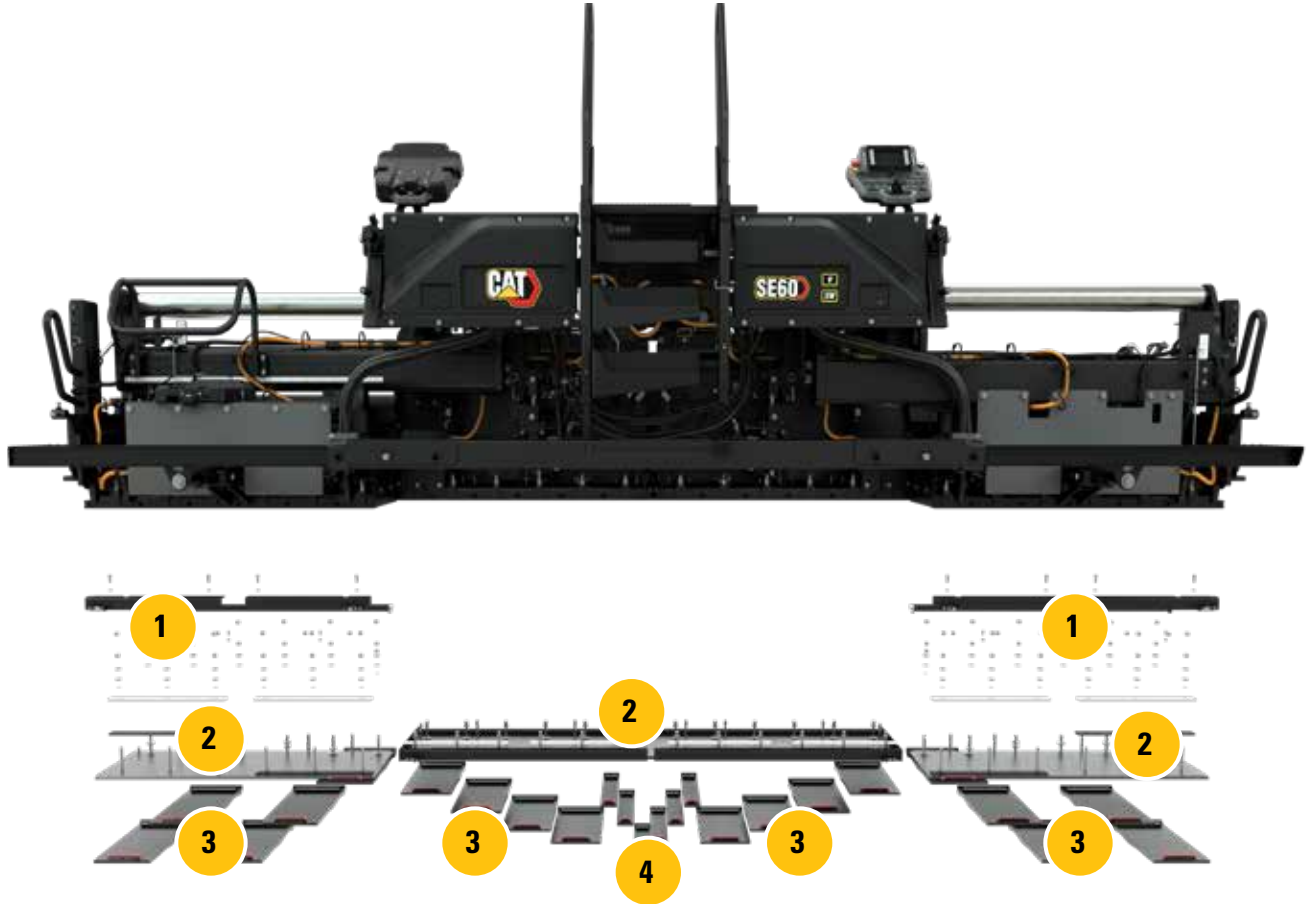

1. Adaptor Plate Hardware
2. Adaptor Plates
3. 300 mm (12") SDX Screed Plates
4. 100 mm (4") SDX Screed Plates
5. Silicone Screed Plate Retainers (Red)

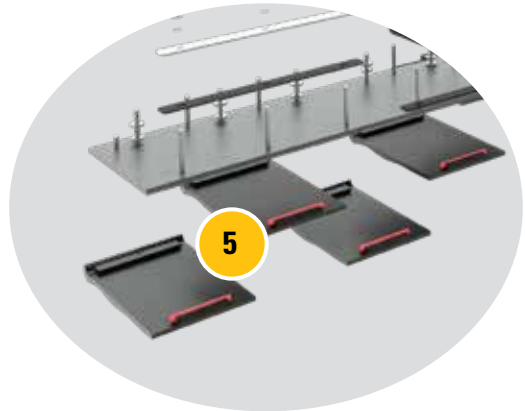

For more complete information on Cat products, dealer services, and industry solutions, visit us on the web at www.cat.com

QEHQ2136-02 (7/24)

© 2024 Caterpillar
All rights reserved

Materials and specifications are subject to change without notice. Featured machines in photos may include additional equipment. See your Cat dealer for available options.

CAT, CATERPILLAR, LET'S DO THE WORK, their respective logos, "Caterpillar Corporate Yellow," the "Power Edge" and Cat "Modern Hex" trade dress as well as corporate and product identity used herein, are trademarks of Caterpillar and may not be used without permission.

