

# engine news

---

product support information for industrial engines

---

21 June 2023

i09809434

## Installation of Cylinder Liner for Engine Models PJ, PK, PP, PR, PT, PU, PV, and PW

**Industrial Engine:**  
**1106C-E70TA, 1106D-E70TA (PV; PW)**  
**1106C-E66TA (PK)**  
**1106-70T (PP; PR; PT; PU)**  
**1106D-E66TA (PJ)**

### Table of Contents

Inspect the Cylinder Block.....	1
Machining of the Cylinder Bore.....	3
Installation of the Cylinder Liner.....	4
Honing the Cylinder Liner.....	6
Cleanliness Specifications of the Cylinder Block.....	7
Storage Procedures .....	8

### **WARNING**

**Do not operate or work on this product unless you have read and understood the instructions and warnings in the relevant Operation and Maintenance Manuals and relevant service literature. Failure to follow the instructions or heed the warnings could result in injury or death. Proper care is your responsibility.**

---

---

### NOTICE

Ensure that the honing specification in this article is met. The honing specification is critical to oil control and ultimately emissions compliance. Perkins recommends that if the required honing specification cannot be met, either a new cylinder block, short engine, or a Perkins remanufactured short engine must be used to ensure emissions compliance.

---

Clean the engine. Refer to Operation and Maintenance Manual, “Engine - Clean” for the correct procedure.

After cleaning the engine, disassemble the engine. Refer to Disassembly and Assembly for the correct procedures.

When removing the connecting rods from the engine, make a note of the connecting rod dimensions and grade for each cylinder. Refer to Specifications, “Connecting Rod” for more information.

### Inspect the Cylinder Block

Clean the parent bores of the cylinder block with a suitable lubricant and a suitable flex hone. Use the flex hone as recommended by the Original Equipment Manufacturer (OEM).

Inspect the parent bores of the cylinder block for wear, damage, distortion, or imperfections.

Inspect the top face of the cylinder block for wear, damage, distortion, or imperfections. This includes all threaded holes and gasket surfaces.

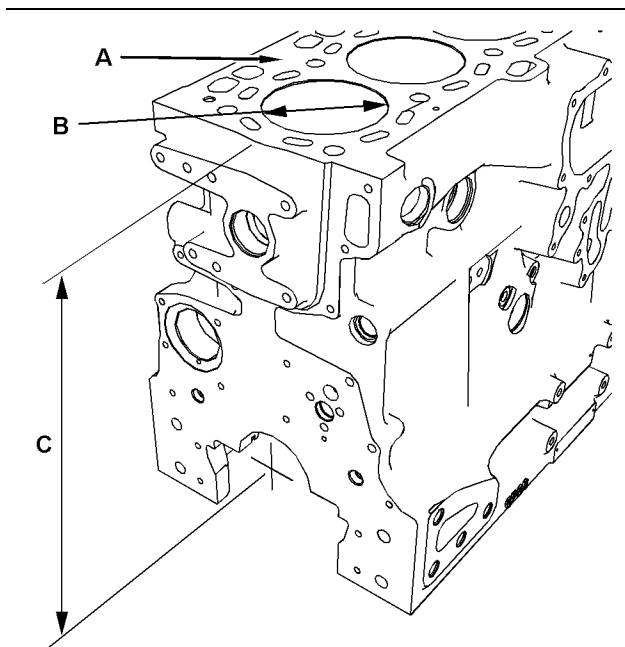

Illustration 1

g02714537

Typical example

Table 1

Cylinder Block Specifications		
Location	Description	Dimension
Top Face (A)	Top face surface texture	Average $\leq 15 \mu\text{m}$ (6 $\mu\text{inch}$ ) Max $\leq 20 \mu\text{m}$ (8 $\mu\text{inch}$ )
	Flatness of top face	The whole top face 0.050 mm (0.00197 inch), 0.025 mm (0.00098 inch) in a 100.00 mm (3.9370 inch) x 100.00 mm (3.9370 inch) area.
Cylinder Bore (B)	New cylinder bore	105.000 to 105.025 mm (4.1338 to 4.1348 inch)
Crankshaft bore to top face of cylinder block (C)	Height of new cylinder block	352.274 to 352.374 mm (13.869 to 13.873 inch)
	Top face height after 0.25 mm (0.0098 inch) is removed	352.024 to 352.124 mm (13.859 to 13.863 inch)
	Top face height after 0.50 mm (0.0197 inch) is removed	351.774 to 351.874 mm (13.849 to 13.853 inch)

Table 2

Top Face Permissible Wave Depth
Wt 0.0004 mm (0.00002 inch) with a wave distance $W_{sm} < 2$ mm (0.0787 inch)
Wt 0.0006 mm (0.00002 inch) with a wave distance $W_{sm} < 4$ mm (0.1575 inch)
Wt 0.0008 mm (0.00003 inch) with a wave distance $W_{sm} < 6$ mm (0.23622 inch)
Wt 0.0010 mm (0.00004 inch) with a wave distance $W_{sm} < 8$ mm (0.31496 inch)

If the top face surface of the cylinder block is machined, the top face should be machined prior to boring the cylinders. The top face height is measured from the centerline of the main bearing bore to the top face surface of the cylinder block.

**Note:** No imperfections are allowed with the outline of the cylinder head gasket sealing bead. In the remaining areas of the cylinder block, a maximum of six imperfections are allowed. The imperfections should be no larger than 3 mm (0.12 inch) in diameter, 1.5 mm (0.06 inch) deep, and a maximum distance of 50 mm (1.97 inch) between each imperfection. Any imperfection should be clean and free from machining debris.

**Note:** To retain the same grades of connecting rod, a new thicker cylinder head gasket should be used when material is removed from the top face of the cylinder block. If 0.25 mm (0.0098 inch) has been removed from the top face of the cylinder block, a new 1.65 mm (0.065 inch) thick cylinder head gasket should be installed to the cylinder block. If 0.50 mm (0.0197 inch) has been removed from the top face of the cylinder block, a new 1.90 mm (0.075 inch) thick cylinder head gasket should be installed to the cylinder block.

For the correct piston height information, refer to Specifications, "Piston and Rings"

Refer to Systems Operation Testing and Adjusting, Piston Height - Inspect for the correct procedure.

Table 3

Cylinder Bore Geometric Tolerance	
Position	0.2 mm (0.0079 inch) diameter
Squareness	0.03 / 100 mm (0.001 / 3.937 inch) diameter
Roundness	0.008 mm (0.0003 inch)
Cylindricity	0.010 mm (0.0004 inch)
Parallelism	0.03 / 100 mm (0.001 / 3.937 inch)

If the parent cylinder bore measures more than the maximum diameter, a cylinder liner should be installed.

# Machining of the Cylinder Bore

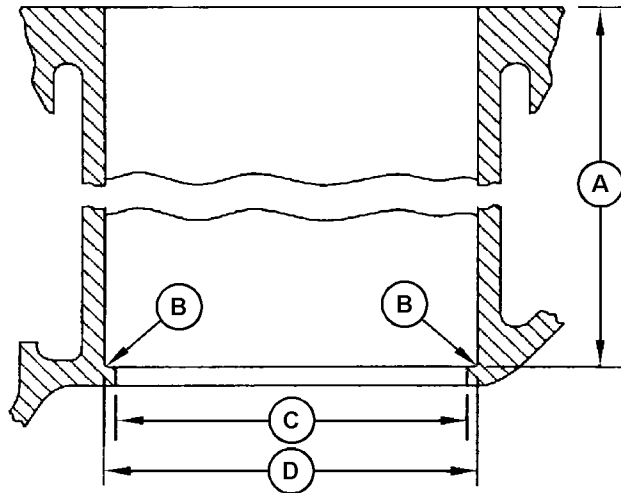

Illustration 2 g07603348  
Machining specifications for cylinder bore in the cylinder block

Table 4

Cylinder Bore in Cylinder Block Machining Dimensions		
Callout	Engine models PJ, and PK	Engine models PP, PR, PT, PU, PV, and PW
(A)	216.5 to 217.5 mm (8.524 to 8.563 inch)	210.5 to 211.5 mm (8.287 to 8.327 inch)
(B)	0.3 mm (0.0118 inch) x 45 degree radius	
(C)	Original cylinder bore diameter	
(D)	107.91 to 107.96 mm (4.248 to 4.250 inch) diameter	
Position (D)	0.2 mm (0.0079 inch) diameter	
Squareness (D)	0.03 / 100 mm (0.001 / 3.937 inch) diameter	
Roughness (D)	Ra 1.6 µm to 2.0 µm	

**Note:** Dimension (C) is original bore diameter, dimension (A) is measured from the top face of the cylinder block.

1. Use suitable tape to prevent the metal debris from entering the oil hole and coolant hole. Position the cylinder block horizontally. Position the boring tool on the cylinder block.



Illustration 3 g07603398  
Typical example

2. Ensure that the top face of the cylinder block around cylinder bore is clean. Use the top face of the cylinder block to confirm the perpendicularity of the boring tool. Adjust the boring tool by measuring four points at top, bottom, left, and right side on top face of the cylinder block around cylinder bore. The recommended variation between the four positions should be within 0.02 mm (0.0008 inch). Refer to illustration 3.

## Installation of the Cylinder Liner



Illustration 4

g07603402

Typical example

3. Ensure that the cylinder bore is clean. Use the centerline of original cylinder bore as a measurement point. Adjust the boring tool position by measuring four points in the cylinder bore at top, bottom, left, and right side, the recommended variation between four positions should be within 0.02 mm (0.0008 inch). Refer to illustration 4.
4. Machine the cylinder bore to the correct diameter and depth. Refer to illustration 2 and Table 4 .
5. Remove the sharp corner and any burrs at the bottom face of bore and edge. Refer to illustration 2 and Table 4 .
6. Measure the cylinder bore dimensions before the cylinder liner is installed. Refer to illustration 2 and Table 4 .



Illustration 5

g07603393

Typical example

1. Apply clean engine oil to the top of cylinder bore for lubrication. Refer to illustration 5.

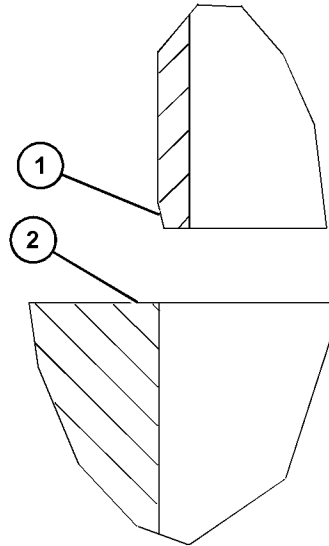

Illustration 6

g07603684

Typical example

2. Install the lower end of the cylinder liner (1) into the top of the cylinder bore. Ensure that the cylinder liner is vertical. Ensure that the "TOP" mark and arrow are orientated towards the top of the cylinder liner.

**Note:** Ensure that the 10 degree outside diameter chamfer is towards the cylinder block (2).

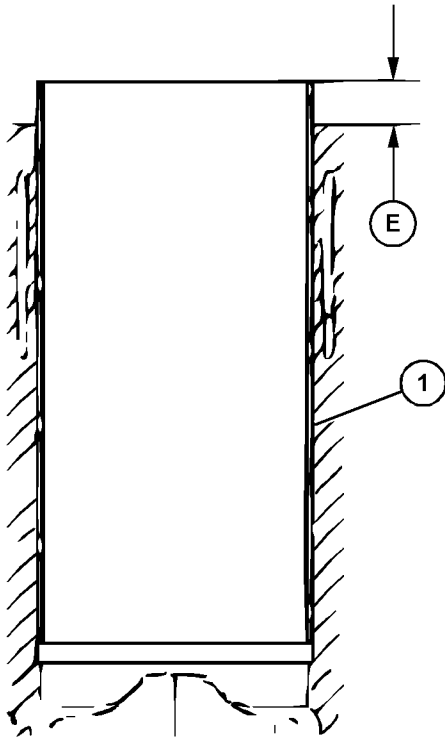

Illustration 7  
Typical example g07604311

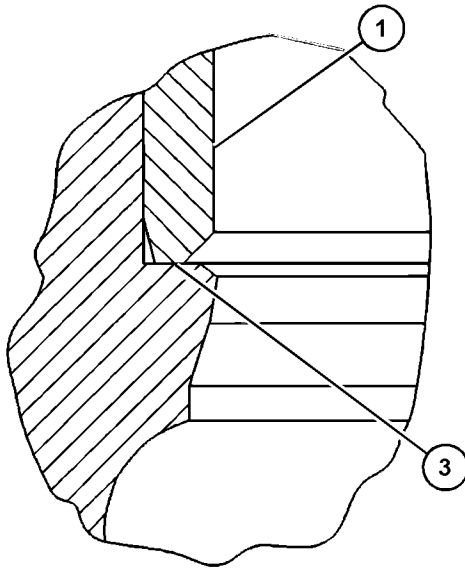

Illustration 8  
Typical example  
Cylinder liner (1) is installed and has complete contact (3) with bottom of cylinder bore g07603913

3. Use a suitable press to push the cylinder liner into the cylinder bore until the bottom of the cylinder liner contacts the counterbore. Temporary marks can be made on the outer surface of the cylinder liner at height (E) from the top of the cylinder liner which is to indicate that the cylinder liner bottom is going to contact the counterbore. Refer to illustration 7 and Table 5. Stop using the press to push the cylinder liner when close to the marking line. Manually press fit the cylinder liner to avoid continuous overloading after the cylinder liner bottom contacts the counterbore.

Table 5

Cylinder Liner Height Above Top Face of Cylinder Block		
Callout	Engine models PJ, and PK	Engine models PP, PR, PT, PU, PV, and PW
(E)	6 mm (0.236 inch)	12 mm (0.472 inch)

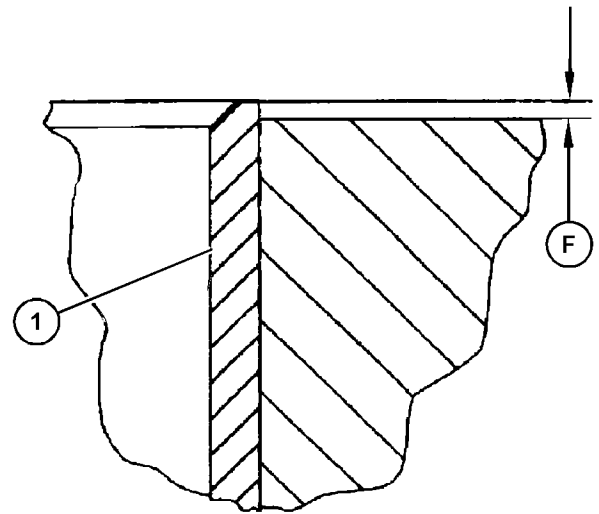

Illustration 9 g07603701

Typical example

(1) Cylinder liner  
(F) Maximum of 0.013 mm (0.00051 inch) above the top face of the cylinder block

#### NOTICE

If the top of the cylinder liner is machined, do NOT nick, or damage to the top face of the cylinder block. To ensure a correct seal between the bottom of the cylinder head and the top surface of the cylinder block near the cylinder liner, the cylinder head gasket MUST have a smooth surface to seal against.

4. After cylinder liner is installed in the cylinder bore, machine the top of the cylinder liner. It is acceptable for the top of the cylinder liner to extend a maximum of 0.013 mm (0.00051 inch), above the cylinder block top face. For best installation results, the cylinder liner should be flush with the top face of the cylinder block.

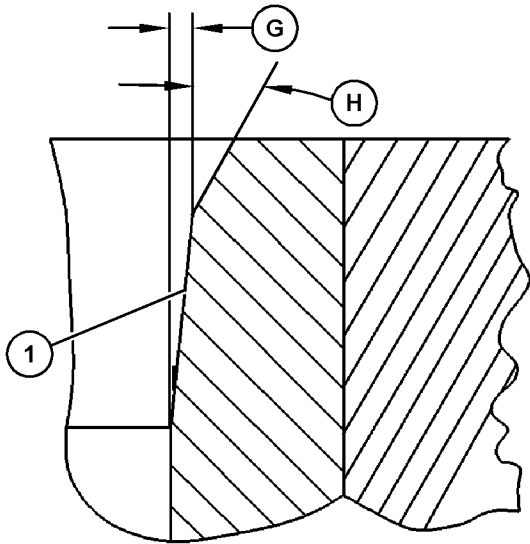

Illustration 10

g07603710

Typical example

Machine chamfer on the top of cylinder liner.

5. Machine a chamfer after the cylinder liner is inserted into the cylinder bore. Refer to Table 6 .

Table 6

Chamfer Dimensions	
Dimension (G)	0.15 to 0.35 mm (0.006 to 0.014 inch)
Dimension (H)	15 to 17 degrees

## Honing the Cylinder Liner

Table 7

Cylinder Liner Bore and Honing Specifications		
Preliminary Bore	Diameter	104.873 to 104.924 mm (4.129 to 4.131 inch)
	Roundness	Ra 3.2 to 4.0µm
	Maximum Out of Round and Taper	≤0.02 mm (0.0008 inch)
Rough honing	Diameter	104.949 to 104.961 mm (4.132 to 4.132 inch)
	Roughness	Ra 2.2 to 3.0µm
	Maximum Out of Round and Taper	≤0.012 mm (0.0005 inch)
Base honing	Diameter	105.000 to 105.025 mm (4.13385 to 4.13483 inch)

(continued)

(Table 7, contd)

Cylinder Liner Bore and Honing Specifications		
	Roughness	Ra 1.3 to 3.0µm
	Maximum Out of Round and Taper	≤0.01 mm (0.0004 inch)
Slide honing	Diameter	105.000 to 105.025 mm (4.13385 to 4.13483 inch)
	Roughness	Ra 0.65 to 1.3µm

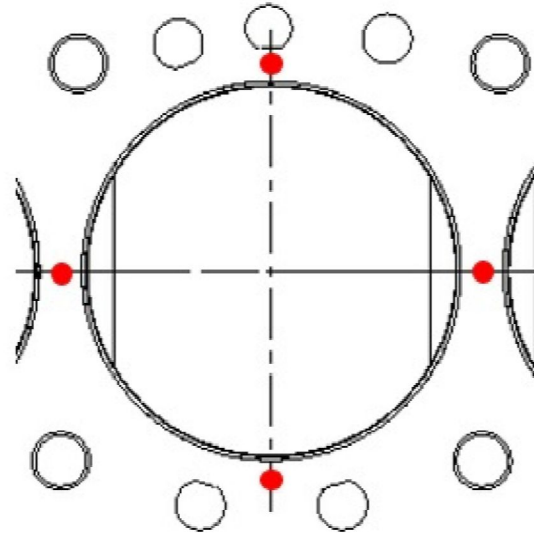

Illustration 11

g07604244

Typical example

1. Use the top face of the cylinder block to confirm the perpendicularity of the boring tool. Adjust the boring tool by measuring four points at top, bottom, left, and right side on the top face around cylinder bore. The recommended variation between four positions should be within 0.02 mm (0.0008 inch). Refer to illustration 11.

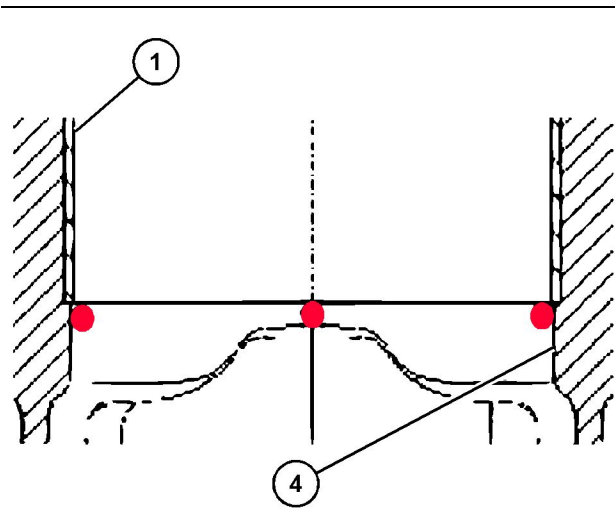

Illustration 12

g07604249

Typical example

- Ensure that the cylinder bore is clean. Use the centerline of original cylinder bore as a measurement point. Adjust the boring tool position by measuring four points in the cylinder bore at top, bottom, left, and right side, the recommended variation between four positions should be within 0.02 mm (0.0008 inch). Refer to illustration 12.

The surface texture of the cylinder bores should meet the requirements in Table 8 .

Table 8

Surface Finish After Honing	
Parameter	Limits
Rpk	0.0002 mm (0.00001 inch)
Rk	0.0002 to 0.0006 mm (0.00001 to 0.00002 inch)
Rvk	0.0008 to 0.0018 mm (0.00003 to 0.00007 inch)
Mr1	<10%
Mr1	65-85%

**Note:** Perkins recommends the use of the Mahr Perthen measuring system when evaluating cylinder bore surface finish parameters. The surface finish parameters have been measured with Mahr Perthen equipment.

**Note:** Rpk, Rk, Rvk, Mr1, and Mr2 are defined by BS EN ISO 13565-2:1998.

**Note:** Rz value may be expected to be less than 5 microns

**Note:** Rz as defined by BS EN ISO 4287:2000

**Note:** The crosshatch of the honing finish is required with a horizontal (tangential to axis of the cylinder bore) inclusive circumferential angle of 30 degrees to 35 degrees when measured midway along the bore.

**Note:** The finished surface shall be cleanly cut and free from excessive tearing, folding, smearing, and foiling. Surface to be uniformly cut in both directions throughout the length of the cylinder bore.

## Cleanliness Specifications of the Cylinder Block

### NOTICE

After finish machining, it is important that the top face of the cylinder block is protected to avoid damage during handling, transit, and assembly until a new cylinder head gasket and cylinder head are installed.

### NOTICE

After machining the coolant passages between the cylinder bores must be free of any machining swarf or residue to allow sufficient coolant flow.

Table 9 lists the maximum permitted contaminant levels for the finished machined cylinder block.

Table 9

Features	Max Contaminant Weight (mg), Cpk = 1.33	Max Particle Size (µm)
All the main bearing cap surfaces. This includes the butt faces, bolt holes and the main bearing cap bolt holes after machining has been completed	28	-
Oilway drillings	10	500
All six cylinder bores	6	-
All oil lubricated surfaces of the cylinder block. This includes the push-rod apertures, chamber for the lifters, bearing caps, and bolts	129	-
Main bearing cap butt faces, bolt holes and bolts. All surfaces after machining	90	-
Water jacket	200	-
Filtration level - 30 µm		

## Storage Procedures

Protection of the cylinder block from corrosion is important. Corrosion will start in as little as 1 hour after the cylinder block has been cleaned.



Illustration 13

g06278538

A typical example of protection for a component that is stored for a shorter term

When the cylinder block will not be inspected for 1 hour or less, the cylinder block should be coated with a rust or corrosion inhibitor or coated with clean engine oil. The cylinder block should be suitably wrapped to prevent contamination, and should be stored in a protected area to avoid damage.

When the cylinder block will not be inspected in two days or more, the cylinder block should be coated with a rust or corrosion inhibitor or coated with clean engine oil and should be placed in a container which is clean and structurally solid. The container should be covered or wrapped in a suitable plastic material to prevent damage and contamination to the cylinder block.

A new camshaft bearing should be installed. Refer to Disassembly and Assembly, "Camshaft Bearings - Remove and Install" for the correct procedure.

Perkins recommends that new crankshaft main bearings and bolts for the main bearings are to be installed. Refer to Disassembly and Assembly, "Crankshaft Main Bearings - Remove and Install" for the correct procedure.

Assemble the remaining engine components. Refer to Disassembly and Assembly for the correct procedures.

■





