



# 637

## Wheel Tractor-Scraper

# Technical Specifications

Configurations and features may vary by region. Please consult your Cat® dealer for availability in your area.

### Table of Contents

<b>Specifications</b> .....	<b>2</b>
Engine .....	2
Engine – Scraper .....	2
General Data .....	2
Non Push-Pull .....	2
Push-Pull .....	2
Transmission .....	2
Service Refill Capacities .....	3
Safety Criteria Compliance Standards .....	3
Weights .....	3
Implement Cycle Times .....	3
Sound .....	3
Air Conditioning System .....	3
Dimensions .....	4
Rimpull-Speed-Gradeability and Retarder Curves .....	5
<b>Standard and Optional Equipment</b> .....	<b>10</b>
<b>637 Environmental Declaration</b> .....	<b>11</b>

# 637 Wheel Tractor-Scraper Specifications

## Engine

Engine Model: Tractor	Cat® C18	
Rated Engine Speed: Tractor	1,900 rpm	
Engine Power (ISO 14396:2002)	425 kW	570 hp

- Meets U.S. EPA Tier 4 Final or EU Stage V emission standards, or equivalent to U.S. EPA Tier 2, or equivalent to U.S. EPA Tier 3 and EU Stage IIIA.

## Engine – Scraper

Engine Model: Tractor	Cat C9.3	
Rated Engine Speed: Tractor	2,150 rpm	
Engine Power (ISO 14396:2002)	216 kW	290 hp

- Meets U.S. EPA Tier 4 Final or EU Stage V emission standards, or equivalent to U.S. EPA Tier 2, and equivalent to U.S. EPA Tier 3 and EU Stage IIIA.
- Net power available at the flywheel when the engine is equipped with fan, air cleaner, aftertreatment, and alternator with engine speed specified.

## General Data

Fuel Tank Refill Capacity: Scraper	763 L	201 gal
Overall Width	3.94 m	12'11"
Overall Shipping Height	3.89 m	12'9"
Scraper Capacity:		
Struck	18.3 m <sup>3</sup>	24.0 yd <sup>3</sup>
Heaped	26.0 m <sup>3</sup>	34.0 yd <sup>3</sup>
Rated Load	37 200 kg 37.2 tonnes	82,200 lb 41.1 tons
Width of Cut	3.51 m	17'7"
Maximum Depth of Cut	450 mm	12.4"
Maximum Depth of Spread	535 mm	21.1"
Top Speed (Loaded)	55.8 km/h	34.7 mph
180° Curb-to-Curb Turning Width	12.23 m	40'2"
Tires:		
Tractor Drive	33.25R29**E3	
Scraper	33.25R29**E3	

## Non Push-Pull

Operating Weight (Empty)	46 600 kg	102,750 lb
Overall Length	15.04 m	49'4"

## Push-Pull

Operating Weight (Empty)	54 005 kg	119,060 lb
Overall Length (With Bail Down)	16.64 m	54'7"

## Transmission

Forward 1	5.5 km/h	3.4 mph
Forward 2	10.0 km/h	6.2 mph
Forward 3	12.4 km/h	7.7 mph
Forward 4	16.9 km/h	10.5 mph
Forward 5	22.7 km/h	14.1 mph
Forward 6	30.6 km/h	19.0 mph
Forward 7	41.4 km/h	25.7 mph
Forward 8	55.8 km/h	34.7 mph
Reverse 1	9.9 km/h	6.2 mph

# 637 Wheel Tractor-Scraper Specifications

## Service Refill Capacities

Differential	158.0 L	41.7 gal
Final Drive (Each)	19.0 L	5.0 gal
Rear Wheels (Each)	4.0 L	1.0 gal
Brake Cooling (Scraper)	33.0 L	8.7 gal
Windshield Washer	5.0 L	1.3 gal
Crankcase (Tractor)	52.0 L	13.7 gal
Transmission System	110 L	29 gal
Cooling System	75 L	19.8 gal
Fuel Tank	874 L	231 gal
Hydraulic System	142 L	37.5 gal
Diesel Exhaust Fluid (DEF)*	30.5 L	8 gal

\*When equipped

## Safety Criteria Compliance Standards

Rollover Protective Structure (ROPS)	ISO 3471:2008 for up to 21 282 kg (46,919 lb)
Falling Objects Protective Structure (FOPS)	ISO 3449:2005 Level II
Brakes	ISO 3450:2011
Steering System	ISO 5010:2019*
Seat Belt	SAE J386
Reverse Alarm	ISO 9533:2010

\*If equipped with optional secondary steering

## Weights

Standard		
Shipping Weight – 10% fuel	50 727 kg	111,834 lb
Operating Weight – full fuel tanks empty load	51 768 kg	114,129 lb
Loaded, based on rated load	88 780 kg	195,726 lb
Push-Pull		
Shipping Weight – 10% fuel	52 592 kg	115,959 lb
Operating Weight – full fuel tanks empty load	53 634 kg	118,243 lb
Loaded, based on a rated load	90 646 kg	199,840 lb

## Implement Cycle Times

Bowl Raise	3.5 seconds
Bowl Lower	3.5 seconds
Apron Raise	4.0 seconds
Apron Lower	3.8 seconds
Ejector Extend	8.5 seconds
Ejector Retract	8.5 seconds
Bail Raise	1.5 seconds
Bail Lower	2.1 seconds

## Sound

- The exterior sound pressure level for the standard machine (ISO 6395:2008) is 119 dB(A).
- The interior sound pressure level for the standard machine (ISO 6396:2008) is 77 dB(A).

## Air Conditioning System

The air conditioning system on this machine contains the fluorinated greenhouse gas refrigerant R134a (Global Warming Potential = 1430). The system contains 1.9 kg (4.2 lb) of refrigerant which has a CO<sub>2</sub> equivalent of 2.71 metric tonnes (2.674 tons).

# 637 Wheel Tractor-Scraper Specifications

## Dimensions

All dimensions are approximate.

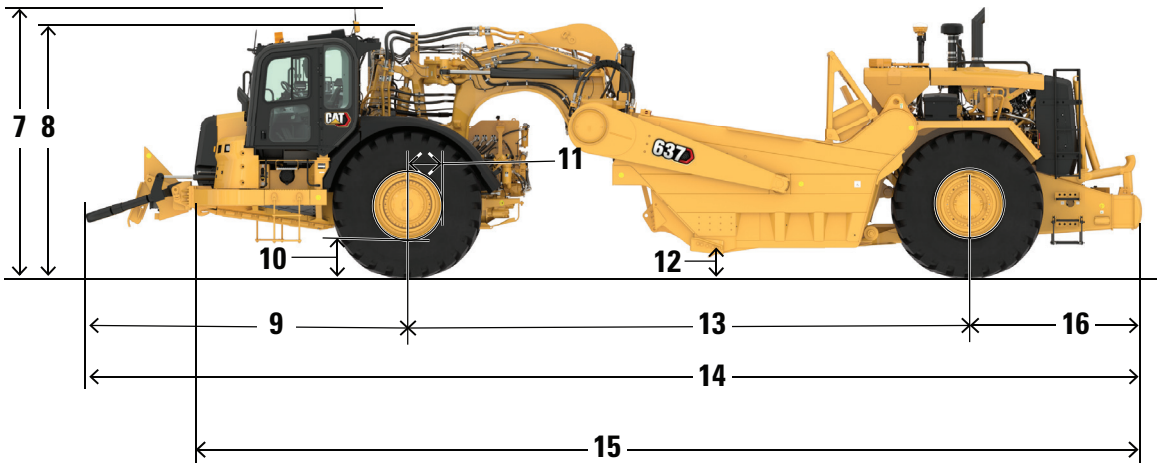
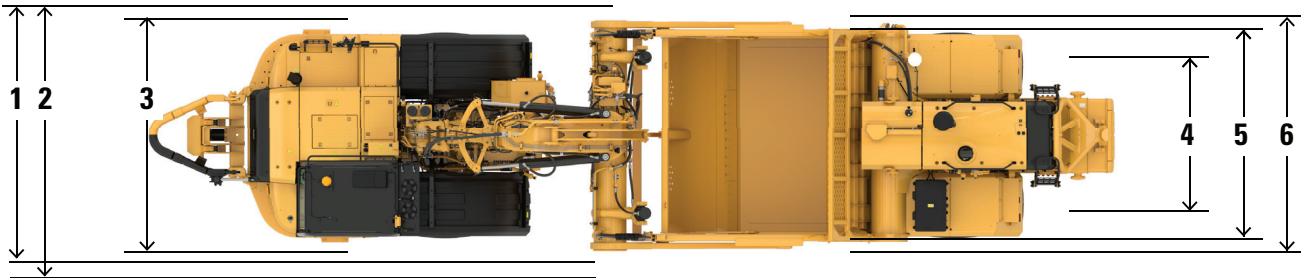

	637	
1 Overall Machine Width	3937 mm	155 in
2 Overall Machine Width – Ladder Down	3878 mm	152.7 in
3 Tractor Width	3499 mm	137.8 in
4 Rear Tire Centers Width	2462 mm	96.9 in
5 Inside of Bowl Width	3404 mm	134 in
6 Outside Bowl Width	3937 mm	155 in
7 Overall Shipping Height	4145 mm	163.2 in
8 Height to Top of Cab	3733 mm	147 in
9 Front of Tractor to Front Axle	3612 mm	142.2 in
10 Ground Clearance – Tractor	664 mm	26.1 in
11 Axle to Vertical Hitch Pin	509 mm	20 in
12 Scraper Blade Height – Maximum	510 mm	20 in
13 Wheelbase	8808 mm	346.8 in
14 Maximum Length – Push-Pull	16 640 mm	655.1 in
15 Overall Machine Length – Standard	15 164 mm	597 in
16 Rear Axle to Rear of Machine	2292 mm	90.2 in

# 637 Wheel Tractor-Scraper Specifications

## Typical Fixed Times Retarder Curves

### TYPICAL FIXED TIMES FOR SCRAPERS

(Times may vary depending on job conditions)

Model	Loaded By	Load Time (Min.)	Maneuver and Spread or Maneuver and Dump (Min.)
613G	Self	0.9	0.7
623K	Self	0.9	0.7
621K	One D8	0.5	0.7
627K	One D8	0.5	0.6
621K	One D9	0.4	0.7
627K	One D9	0.4	0.6
627K/PP	Self	0.9*	0.6
631K	One D9	0.6	0.7
637K	One D9	0.6	0.6
631K	One D10	0.5	0.7
637K	One D10	0.5	0.6
637K/PP	Self	1.0*	0.6
657G	One D11	0.6	0.6
657G	Push Pull Self	1.1*	0.6
637K	Coal	0.8	0.7
657G	Coal	0.8	0.6

\*Load time per pair, including transfer time.

**Note:** Empty weights shown on the wheel tractor-scraper charts include ROPS cab. When calculating TMPH loadings, any additional weight must be considered in establishing mean tire loads.

### USE OF RETARDER CURVES

The following explanation applies to retarder curves for wheel tractor-scrappers and articulated trucks.

The speed that can be maintained (without use of service brake) when the machine is descending a grade with retarder fully on can be determined from the retarder curves in this section if gross machine weight and total effective grade are known.

**Total effective grade (or total resistance)** is grade assistance minus rolling resistance.

$$10 \text{ kg/metric ton (20 lb/U.S. ton)} = 1\% \text{ adverse grade}$$

*Example:*

**15% favorable grade with 5% rolling resistance.** Find total effective grade.

$$\text{Total effective grade} = 15\% \text{ grade assistance} - 5\%$$

$$\text{Rolling resistance} = 10\% \text{ total effective grade assistance}$$

*Example Problem:*

**A 637 with an estimated payload of 47 175 kg (104,000 lb) descends a 10% total effective grade.** Find constant speed and gear range with maximum retarder effort. Find travel time if the slope is 610 m (2,000 ft) long.

$$\begin{aligned} \text{Empty weight} + \text{payload} &= \text{gross weight} = 60\,950 \text{ kg} + 47\,175 \text{ kg} \\ &= 108\,125 \text{ kg (134,370 lb + 104,000 lb = 238,370 lb)} \end{aligned}$$

# 637 Wheel Tractor-Scraper Specifications

## Rimpull-Speed-Gradeability Curves

### USE OF RIMPULL-SPEED-GRADEABILITY CURVES

The following explanation applies to Rimpull-Speed-Gradeability curves for wheel tractor-scraper, construction and mining trucks/tractors, and articulated trucks.

Maximum speed attainable, gear range, and available rimpull can be determined from curves on the following pages when machine weight and total effective grade (or total resistance) are known.

**Rimpull is the force** (in kg, lb, or kN) available between the tire and the ground to propel the machine (limited by traction).

**Weight** is defined as gross machine weight (kg or lb)  
= machine + payload

**Total effective grade (or total resistance)** is grade resistance plus rolling resistance expressed as percent grade.

Grade is measured or estimated.

Rolling resistance is estimated (see tables section for typical values).

10 kg/metric ton (20 lb/U.S. ton) = 1% adverse grade

*Example:*

**With a 6% grade and a rolling resistance of 40 kg/metric ton (80 lb/U.S. ton), find total resistance.**

Rolling resistance =  $40 \text{ kg/t} \div 10 = 4\%$  effective grade  
(English:  $80 \text{ lb} \div 20 = 4\%$ )

Total resistance = 4% rolling + 6% grade = 10%

### Altitude Derating

Rimpull force and speed must be derated for altitude similar to flywheel horsepower. The percentage loss in rimpull force approximately corresponds to the percentage loss in flywheel horsepower. See tables section for altitude derations.

### Rimpull-Speed-Gradeability

To determine gradeability performance: Read from gross weight down to the % of total resistance. [Total resistance equals actual % grade plus 1% for each 10 kg/metric ton (20 lb/U.S. ton) of rolling resistance.]

From this weight-resistance point, read horizontally to the curve with the highest obtainable speed range, then down to the maximum speed. Usable rimpull depends upon traction and weight on drive wheels.

#### Example Problem:

**A 637 with an estimated payload of 37 013 kg (81,600 lb) is operating on a total effective grade of 10%.** Find the available rimpull and maximum attainable speed.

Empty weight + payload = gross weight

$47\,628 \text{ kg} + 37\,013 \text{ kg} = 84\,641 \text{ kg}$

$(105,002 \text{ lb} + 81,600 \text{ lb} = 186,602 \text{ lb})$

**Solution:** Using graph on the next page, read from 84 641 kg (186,602 lb) (point A) on top of gross weight scale down the line to the intersection of the 10% total resistance line (point B).

Go across horizontally from B to the rimpull scale on the left (point D). This gives the required rimpull: 7756 kg (17,100 lb).

Where the line cuts the speed curve (point C), read down vertically (point E) to obtain the maximum speed attainable for the 10% effective grade: 12.9 km/h (8 mph).

**Answer:** The machine will climb the 10% effective grade at a maximum speed of 12.9 km/h (8 mph) in 4th gear. Available rimpull is 7756 kg (17,100 lb).

# 637 Wheel Tractor-Scraper Specifications

## Rimpull-Speed-Gradeability Curves

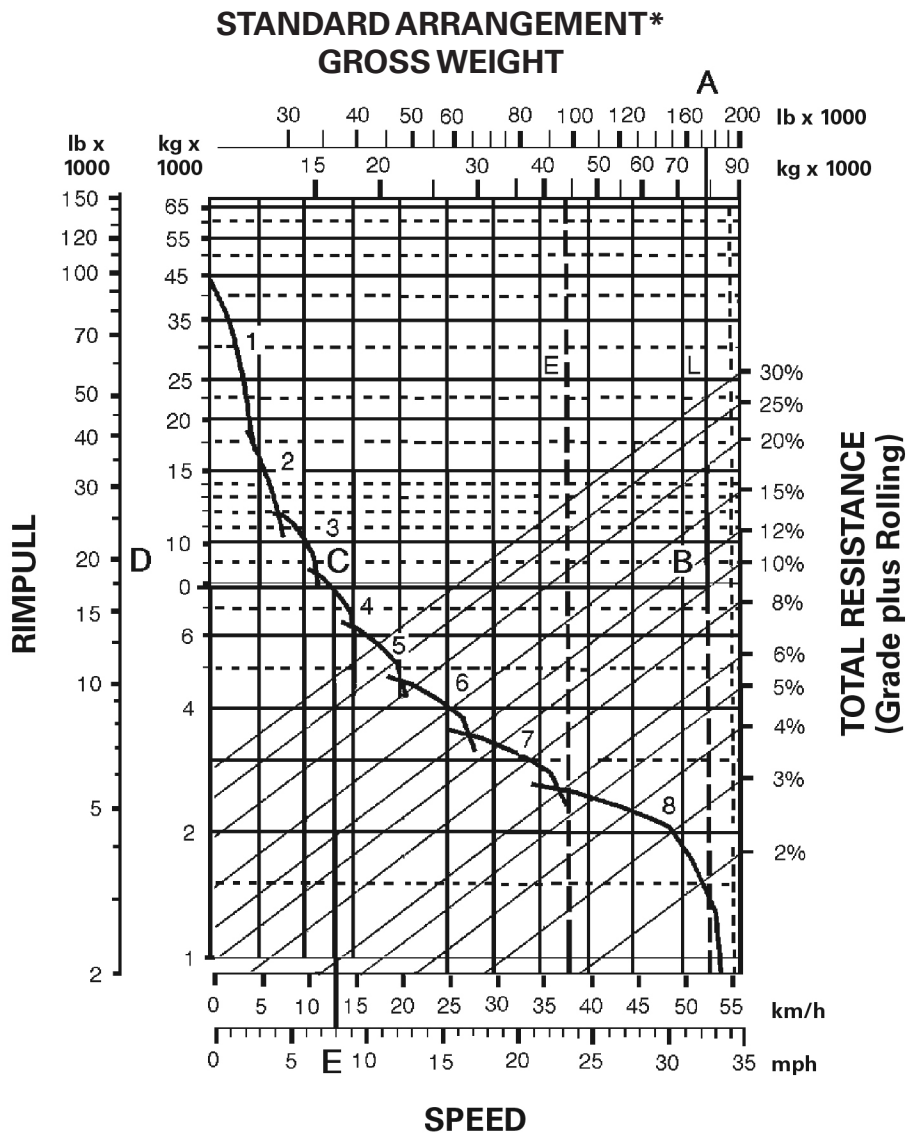

**KEY**

- 1 — 1st Gear Torque Converter Drive
- 2 — 2nd Gear Torque Converter Drive
- 3 — 3rd Gear Direct Drive
- 4 — 4th Gear Direct Drive
- 5 — 5th Gear Direct Drive
- 6 — 6th Gear Direct Drive
- 7 — 7th Gear Direct Drive
- 8 — 8th Gear Direct Drive

**KEY**

- A — Loaded 84 641 kg (186,602 lb)
- B — Intersection with 10% total resistance line
- C — Intersection with rimpull curve (4th gear)
- D — Required rimpull 7756 kg (17,100 lb)
- E — Speed 12.9 km/h (8 mph)

\*At sea level

# 637 Wheel Tractor-Scraper Specifications

## Retarder Curves

**Solution:** Using the retarder curve below, read from 108 125 kg (238,370 lb) (point A) on top of gross weight scale down the line to the intersection of the 10% effective grade line (point B).

Go across horizontally from point B to the intersection of the retarder curve (point C). Point C intersects at the 5 (5th gear) range.

Where point C intersects the retarder curve, read down vertically to point D on the bottom scale to obtain the constant speed: 21.7 km/h (13.5 mph).

**Answer:** The 637 will descend the slope at 21.7 km/h (13.5 mph) in 5th gear. Travel time is 1.68 minutes.

$$\frac{610 \text{ m}}{363 \text{ m/min}} = 1.68 \text{ min}$$

\* (mph x 88 = F.P.M.)

$$\frac{2,000 \text{ ft}}{13.5 \text{ mph} \times 88^*} = 1.68 \text{ min}$$

**Note:** The basic distance-speed-time formula is  $60 D \div S = T$  (or “60 D Street”), where 60 is minutes, D is distance, S is speed, and T is time. In the above problem,  $60 \times 610 \text{ m} \div 21.7 \text{ km/h} \times 1000 = T$ .

$$\frac{60 \times 610}{21.7 \times 1000} = T = (1.68)$$

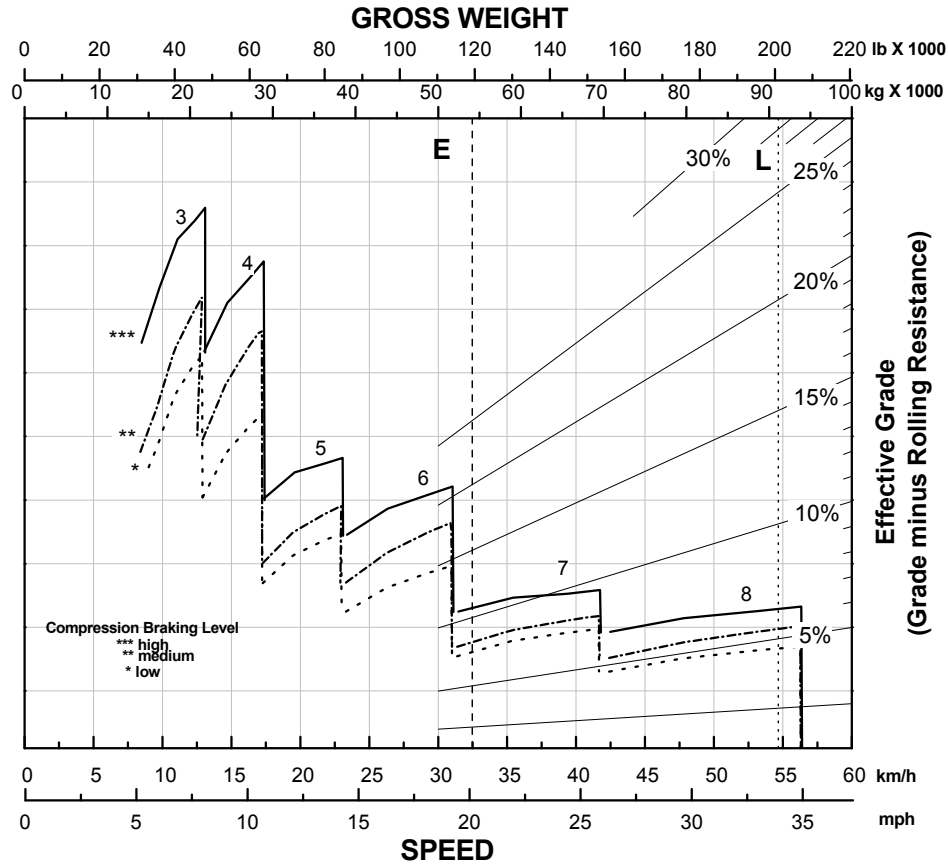

### KEY

- 3 — 3rd Gear Direct Drive
- 4 — 4th Gear Direct Drive
- 5 — 5th Gear Direct Drive
- 6 — 6th Gear Direct Drive
- 7 — 7th Gear Direct Drive
- 8 — 8th Gear Direct Drive

### KEY

- A — Loaded 108 125 kg (238,370 lb)
- B — Intersection with 10% effective grade line
- C — Intersection with retarder curve (5th gear)
- D — Constant speed 21.7 km/h (13.5 mph)



# 637 Wheel Tractor-Scraper Specifications

## Rimpull-Speed-Gradeability – 33.25R29 Tires

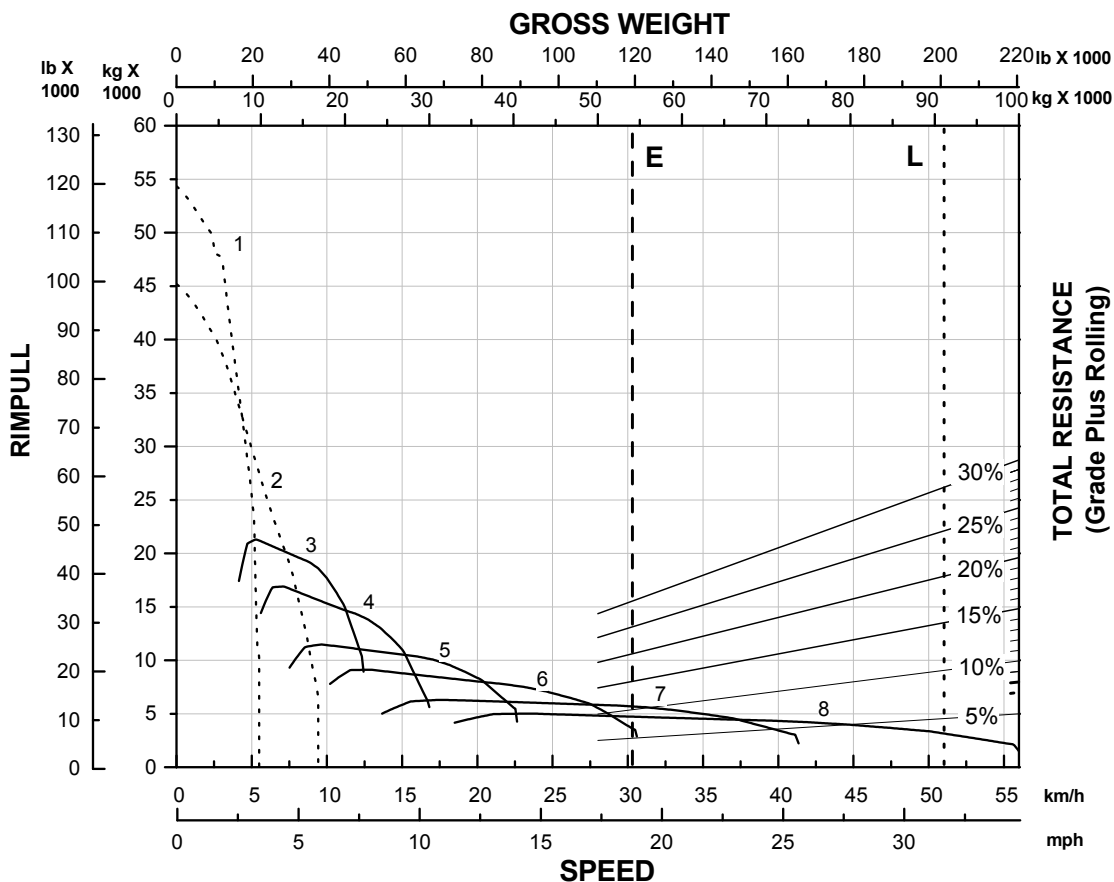

**KEY**

- 1 – 1st Gear Torque Converter Drive
- 2 – 2nd Gear Torque Converter Drive
- 3 – 3rd Gear Direct Drive
- 4 – 4th Gear Direct Drive
- 5 – 5th Gear Direct Drive
- 6 – 6th Gear Direct Drive
- 7 – 7th Gear Direct Drive
- 8 – 8th Gear Direct Drive

**KEY**

- E – Empty 35 808 kg (78,943 lb)
- L – Loaded 61 935 kg (136,553 lb)

# 637 Wheel Tractor-Scraper Standard Equipment

## Standard and Optional Equipment

Standard equipment and optional attachments may vary. Consult your Cat® dealer for details.

	Standard	Optional		Standard	Optional
<b>POWERTRAIN – TRACTOR</b>			<b>OPERATOR ENVIRONMENT – TRACTOR (continued)</b>		
Cat C18 engine with Mechanically Actuated Electronic Unit Injection (MEUI™)	✓		Keypad switches: throttle lock, wipers/washers, hazard lights, retarding level select, work lights on/off, information mode on messenger display	✓	
Cat engine brake	✓		Powered access		✓
Electric start, 24V	✓		Safety tab rocker switches	✓	
Fan, hydraulic	✓		Seat – Cat Advanced Ride Management (ARM), Cat Comfort Series III, rotates 30 degrees	✓	
Ground level engine shutdown	✓		Steering wheel, tilt, telescoping, padded	✓	
Guard, crankcase	✓		Windows, right side emergency egress	✓	
Starting aid, ether	✓		Messenger display	✓	
Braking system: primary and secondary, wet disc, hydraulic; parking, hydraulic-released, spring-applied	✓		<b>FLUIDS</b>		
Transmission: 8-speed planetary powershift, Electronic Clutch Pressure Control (ECPC), Advanced Productivity Electronic Control Strategy (APECS) software, programmable top gear selection, transmission hold, differential lock, transmission guard, ground speed control, machine speed limit	✓		Extended life coolant to -37° C (-34° F)	✓	
<b>POWERTRAIN – SCRAPER</b>			<b>OTHER STANDARD EQUIPMENT – TRACTOR</b>		
Cat C9.3 engine with high pressure common rail fuel	✓		Advanced cushion hitch	✓	
Cat engine brake	✓		Accumulators (cushion hitch and brake) with Canadian registration number (CRN)	✓	
Electric start, 24V	✓		Fast oil change (engine)	✓	
Fan, driveline	✓		Fenders, non-metallic	✓	
Ground engine shutdown	✓		Heater, engine coolant 120V	✓	
Muffler (U.S. EPA Tier 2 or U.S. EPA Tier 3 only)	✓		Tow pin, front	✓	
Starting aid, ether	✓		<b>OTHER STANDARD EQUIPMENT – SCRAPER</b>		
Braking system: primary and secondary, dry disc, hydraulic; 4 speed (torque converter drive), transmission planetary powershift	✓		Bowl: 18.3 m <sup>3</sup> (24.0 yd <sup>3</sup> ) – struck, 26.0 m <sup>3</sup> (34.0 yd <sup>3</sup> ) – heaped	✓	
<b>ELECTRICAL – TRACTOR</b>			Hydraulic position sensing cylinders (bowl lift and apron)	✓	
Alternator, 115 amp	✓		<b>STEERING ARRANGEMENTS</b>		
Batteries (4), 12V, 1,000 CCA, maintenance free	✓		Secondary steering (ground driven)	✓	
Electrical system, 24V	✓		<b>INTEGRATED TECHNOLOGIES</b>		
Lighting system: LED low beam, high beam, and work lights	✓		Product Link™	✓	
Starting/charging receptacle	✓		Sequence Assist and Cat Payload	✓	
<b>ELECTRICAL – SCRAPER</b>			Cat Grade Control, Cat Payload, Sequence Assist, and Load Assist	✓	
Alarm, backup	✓		<b>OTHER ATTACHMENTS</b>		
Lighting system: brake lights – LED, turn signals with hazard function – LED	✓		Push-pull	✓	
<b>OPERATOR ENVIRONMENT – TRACTOR</b>			Fast-fill fuel tank	✓	
HVAC powered air precleaner	✓		Camera arrangement – Work Area Vision System (WAVS)	✓	
HVAC system, heat, AC, defrost	✓		Steering lock – external	✓	
Thermostat control of HVAC system	✓		Cab beacon with air horn	✓	
Coat hook	✓		Fender, scraper	✓	
Lunchbox platform with holding strap	✓		Guard, overflow	✓	
Diagnostic connection (2)	✓		Year of manufacture plate	✓	
Dome courtesy light	✓		<b>SERVICE INSTRUCTIONS</b>		
Horn, electric	✓		Film arrangement – U.S. (ANSI)	✓	
T-handle implement control	✓		Film arrangement – International (ISO)	✓	
Radio ready	✓				
Rollover protective structure (ROPS)/falling objects protective structure (FOPS) cab, pressurized	✓				

The following information applies to the machine at the time of final manufacture as configured for sale in the regions covered in this document. The content of this declaration is valid as of the date issued; however, content related to machine features and specifications are subject to change without notice. For additional information, please see the machine's Operation and Maintenance Manual.

For more information on sustainability in action and our progress, please visit <https://www.caterpillar.com/en/company/sustainability>.

## Engine

- The Cat® C13 engine is available in configurations that meet U.S. EPA Tier 4 Final and EU Stage V emission standards or equivalent to U.S. EPA Tier 2, or equivalent to U.S. EPA Tier 3 and EU Stage IIIA.
- Cat U.S. EPA Tier 4 Final and EU Stage V diesel engines are required to use ULSD (ultra-low sulfur diesel fuel with 15 ppm of sulfur or less) or ULSD blended with the following lower-carbon intensity fuels\*\*\* up to:
  - ✓ 20% biodiesel FAME (fatty acid methyl ester)\*
  - ✓ 100% renewable diesel, HVO (hydrotreated vegetable oil) and GTL (gas-to-liquid) fuels
- Cat engines meeting equivalent to U.S. EPA Tier 2, or equivalent to U.S. EPA Tier 3 and EU Stage IIIA, are compatible with diesel fuel blended with the following lower-carbon intensity fuels\*\*\* up to:
  - ✓ 100% biodiesel FAME (fatty acid methyl ester)\*\*
  - ✓ 100% renewable diesel, HVO (hydrotreated vegetable oil) and GTL (gas-to-liquid) fuels

Refer to guidelines for successful application. Please consult your Cat dealer or “Caterpillar Machine Fluids Recommendations” (SEBU6250) for details.

*\*Engines with no aftertreatment devices can use higher blends, up to 100% biodiesel (for use of blends higher than 20% biodiesel, consult your Cat dealer).*

*\*\*For use of blends higher than 20% biodiesel, consult your Cat dealer.*

*\*\*\*Tailpipe greenhouse gas emissions from lower-carbon intensity fuels are essentially the same as traditional fuels.*

## Air Conditioning System

- The air conditioning system on this machine contains the fluorinated greenhouse gas refrigerant R134a (Global Warming Potential = 1430). The system contains 1.9 kg (4.2 lb) of refrigerant which has a CO<sub>2</sub> equivalent of 2.71 metric tonnes (2.674 tons).

## Paint

- Based on best available knowledge, the maximum allowable concentration, measured in parts per million (PPM), of the following heavy metals in paint are:
  - Barium < 0.01%
  - Cadmium < 0.01%
  - Chromium < 0.01%
  - Lead < 0.01%

## Sound

- The exterior sound pressure level for the standard machine (ISO 6395:2008) is 119 dB(A).
- The interior sound pressure level for the standard machine (ISO 6396:2008) is 77 dB(A).

## Oils and Fluids

- Caterpillar factory fills with ethylene glycol coolants. Cat Diesel Engine Antifreeze/Coolant (DEAC) and Cat Extended Life Coolant (ELC) can be recycled. Consult your Cat dealer for more information.
- Cat Bio HYDO Advanced is an EU Ecolabel approved biodegradable hydraulic oil.
- Additional fluids are likely to be present, please consult the Operations and Maintenance Manual or the Application and Installation guide for complete fluid recommendations and maintenance intervals.

## Features and Technology

- The following features and technology contribute to fuel savings and/or carbon reduction. Features may vary. Consult your Cat dealer for details.
  - Ground speed control helps lower fuel burn by allowing the operator to set the desired top speed and the machine will find the optimal gear for the engine and transmission
  - Optional Load Assist helps shorten the learning curve for inexperienced operators
  - Advanced Productivity Electronic Control System (APECS) allows the engines and transmission to communicate on a high level to better utilize the power and torque
  - Optional Cat Grade Control helps operators of all skill levels avoid costly rework, wasteful fuel burn, and greenhouse gas emissions to execute the design plan with greater speed and accuracy
  - Reduced chain wear with the enhanced elevator drive sprocket
  - Decreased sprocket wear, chain wear, and chain jumping with improved scissor-style chain
  - On-demand hydraulic fan helps reduce fuel consumption and under-hood heat for longer component life
  - Improve jobsite efficiency with lower operating costs with Product Link™ and VisionLink® insights

For more complete information on Cat products, dealer services, and industry solutions, visit us on the web at [www.cat.com](http://www.cat.com).

Materials and specifications are subject to change without notice. Featured machines in photos may include additional equipment. See your Cat dealer for available options.

© 2024 Caterpillar. All Rights Reserved. CAT, CATERPILLAR, LET'S DO THE WORK, their respective logos, Product Link, MEUI, "Caterpillar Corporate Yellow", the "Power Edge" and Cat "Modern Hex" trade dress as well as corporate and product identity used herein, are trademarks of Caterpillar and may not be used without permission.

VisionLink is a trademark of Caterpillar Inc., registered in the United States and in other countries.

AEXQ3594-01 (11-2024)  
Replaces AEXQ3594-00  
Build Number: 11A  
(Global, excluding Japan)

