



# 631

## Wheel Tractor-Scraper

# Technical Specifications

Configurations and features may vary by region. Please consult your Cat® dealer for availability in your area.

### Table of Contents

<b>Specifications</b> .....	<b>2</b>
Engine .....	2
General Data .....	2
Non Push-Pull .....	2
Push-Pull .....	2
Transmission .....	2
Service Refill Capacities .....	3
Safety Criteria Compliance Standards .....	3
Weights .....	3
Implement Cycle Times .....	3
Cab .....	3
Air Conditioning System .....	3
Dimensions .....	4
Rimpull-Speed-Gradeability and Retarder Curves .....	5
<b>Standard Equipment</b> .....	<b>11</b>
<b>Standard and Optional Attachments</b> .....	<b>12</b>
<b>Environmental Declaration</b> .....	<b>13</b>

# 631 Wheel Tractor-Scraper Specifications

## Engine

Engine Model: Tractor	Cat® C18	
Rated Engine Speed: Tractor	1,900 rpm	
Engine Power (ISO 14396:2002)	425 kW	570 hp

- Meets U.S. EPA Tier 4 Final or EU Stage V emission standards, or equivalent to U.S. EPA Tier 2, or equivalent to U.S. EPA Tier 3 and EU Stage IIIA.

## General Data

Fuel Tank Refill Capacity: Scraper	763 L	201 gal
Overall Width	3.94 m	12'11"
Overall Shipping Height	3.89 m	12'9"
Scraper Capacity:		
Struck	18.3 m <sup>3</sup>	24.0 yd <sup>3</sup>
Heaped	26.0 m <sup>3</sup>	34.0 yd <sup>3</sup>
Rated Load	37 200 kg 37.2 tonnes	82,200 lb 41.1 tons
Width of Cut	3.51 m	17'7"
Maximum Depth of Cut	450 mm	12.4"
Maximum Depth of Spread	535 mm	21.1"
Top Speed (Loaded)	55.8 km/h	34.7 mph
180° Curb-to-Curb Turning Width	12.23 m	40'2"
Tires:		
Tractor Drive	33.25R29**E3	
Scraper	33.25R29**E3	

## Non Push-Pull

Operating Weight (Empty)	46 600 kg	102,750 lb
Overall Length	15.04 m	49'4"

## Push-Pull

Operating Weight (Empty)	48 275 kg	106,430 lb
Overall Length (With Bail Down)	16.64 m	54'7"

## Transmission

Forward 1	5.5 km/h	3.4 mph
Forward 2	10.0 km/h	6.2 mph
Forward 3	12.4 km/h	7.7 mph
Forward 4	16.9 km/h	10.5 mph
Forward 5	22.7 km/h	14.1 mph
Forward 6	30.6 km/h	19.0 mph
Forward 7	41.4 km/h	25.7 mph
Forward 8	55.8 km/h	34.7 mph
Reverse 1	9.9 km/h	6.2 mph

# 631 Wheel Tractor-Scraper Specifications

## Service Refill Capacities

Differential	158.0 L	41.7 gal
Final Drive (Each)	19.0 L	5.0 gal
Rear Wheels (Each)	4.0 L	1.0 gal
Brake Cooling (Scraper)	33.0 L	8.7 gal
Windshield Washer	5.0 L	1.3 gal
Crankcase (Tractor)	52.0 L	13.7 gal
Transmission System	110 L	29 gal
Cooling System	75 L	19.8 gal
Fuel Tank	874 L	231 gal
Hydraulic System	142 L	37.5 gal
Diesel Exhaust Fluid (DEF)*	30.5 L	8 gal

\*When equipped

## Safety Criteria Compliance Standards

Rollover Protective Structure (ROPS)	ISO 3471:2008 for up to 21 282 kg (46,919 lb)
Falling Object Protective Structure (FOPS)	ISO 3449:2005 Level II
Brakes	ISO 3450:2011
Steering System	ISO 5010:2007
Seat Belt	SAE J386:FEB2006
Reverse Alarm	ISO 9533:2010

## Weights

Standard		
Shipping Weight – 10% fuel	35 507 kg	78,279 lb
Operating Weight – full fuel tanks	36 387 kg	80,219 lb
Operating Weight – empty	36 185 kg	79,787 kg
Loaded, based on rated load	62 553 kg	137,905 lb
Push-Pull		
Shipping Weight – 10% fuel	36 782 kg	81,090 lb
Operating Weight – full fuel tanks	37 713 kg	83,143 lb
Loaded, based on a rated load	63 879 kg	140,829 lb

## Implement Cycle Times

Bowl Raise	3.5 Seconds
Bowl Lower	3.5 Seconds
Apron Raise	4.0 Seconds
Apron Lower	3.8 Seconds
Ejector Extend	8.5 Seconds
Ejector Retract	8.5 Seconds
Bail Raise	1.5 Seconds
Bail Lower	2.1 Seconds

## Cab

ROPS/FOPS	ISO 3471:2008 ISO 3449:2005 Level II
-----------	-----------------------------------------

- The exterior sound power level for the standard machine (ISO 6393:2008) is 116.5 dB(A).

## Air Conditioning System

The air conditioning system on this machine contains the fluorinated greenhouse gas refrigerant R134a (Global Warming Potential = 1430). The system contains 1.9 kg (4.2 lb) of refrigerant which has a CO<sub>2</sub> equivalent of 2.71 metric tonnes (2.674 tons).

# 631 Wheel Tractor-Scraper Specifications

## Dimensions

All dimensions are approximate.

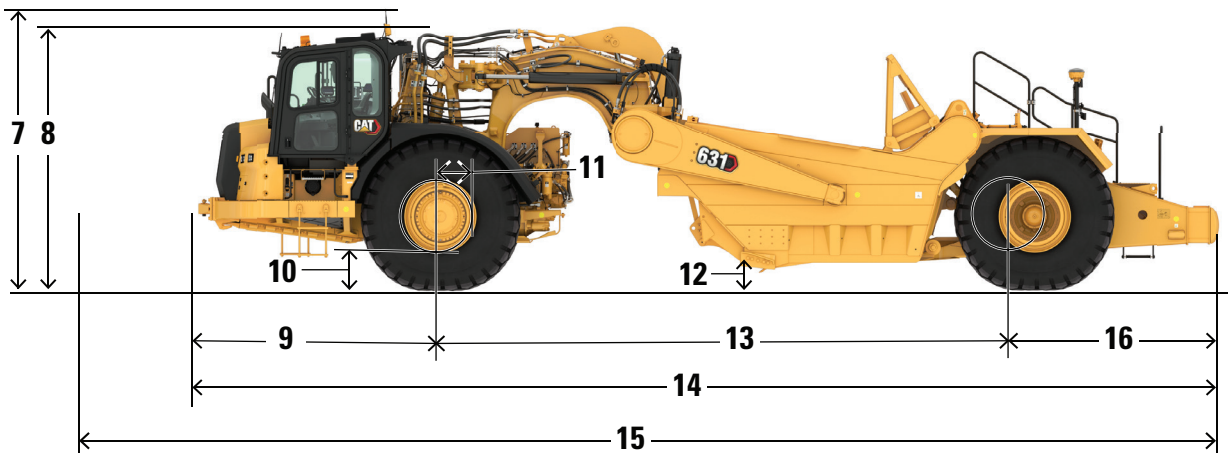
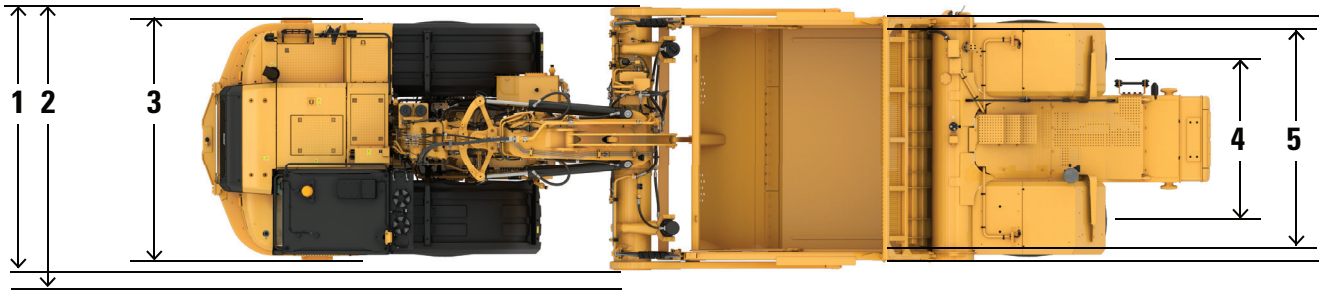

	631	
1 Overall Machine Width	3585 mm	141.1 in
2 Overall Machine Width – Ladder Down	3790 mm	149.2 in
3 Tractor Width	3381 mm	133.1 in
4 Rear Tire Centers Width	2290 mm	90.2 in
5 Inside of Bowl Width	3048 mm	120.0 in
6 Outside Bowl Width	3250 mm	128.0 in
7 Overall Shipping Height	4029 mm	158.6 in
8 Height to Top of Cab	3612 mm	142.2 in
9 Front of Tractor to Front Axle	3119 mm	122.8 in
10 Tractor Ground Clearance	557 mm	21.9 in
11 Axle to Vertical Hitch Pin	540 mm	21.3 in
12 Scraper Blade Height – Maximum	540 mm	21.3 in
13 Wheelbase	7998 mm	314.9 in
14 Overall Machine Length – Standard	14 015 mm	551.8 in
15 Maximum Length – Push-Pull	15 576 mm	613.2 in
16 Rear Axle to Rear of Machine	2898 mm	114.1 in

# 631 Wheel Tractor-Scraper Specifications

## Typical Fixed Times Retarder Curves

### TYPICAL FIXED TIMES FOR SCRAPERS

(Times may vary depending on job conditions)

Model	Loaded By	Load Time (Min.)	Maneuver and Spread or Maneuver and Dump (Min.)
613G	Self	0.9	0.7
623K	Self	0.9	0.7
621K	One D8	0.5	0.7
627K	One D8	0.5	0.6
621K	One D9	0.4	0.7
627K	One D9	0.4	0.6
627K/PP	Self	0.9*	0.6
631K	One D9	0.6	0.7
637K	One D9	0.6	0.6
631K	One D10	0.5	0.7
637K	One D10	0.5	0.6
637K/PP	Self	1.0*	0.6
657G	One D11	0.6	0.6
657G	Push Pull Self	1.1*	0.6
637K	Coal	0.8	0.7
657G	Coal	0.8	0.6

\*Load time per pair, including transfer time.

**Note:** Empty weights shown on the wheel tractor-scraper charts include ROPS canopy. When calculating TMPH loadings, any additional weight must be considered in establishing mean tire loads.

### USE OF RETARDER CURVES

The following explanation applies to retarder curves for wheel tractor-scrappers and articulated trucks.

The speed that can be maintained (without use of service brake) when the machine is descending a grade with retarder fully on can be determined from the retarder curves in this section if gross machine weight and total effective grade are known.

**Total effective grade (or total resistance)** is grade assistance minus rolling resistance.

10 kg/metric ton (20 lb/U.S. ton) = 1% adverse grade

*Example:*

**15% favorable grade with 5% rolling resistance.** Find total effective grade.

Total effective grade = 15% grade assistance – 5%

Rolling resistance = 10% total effective grade assistance

*Example Problem:*

**A 631 with an estimated payload of 47 175 kg (104,000 lb) descends a 10% total effective grade.** Find constant speed and gear range with maximum retarder effort. Find travel time if the slope is 610 m (2,000 ft) long.

Empty weight + payload = gross weight = 60 950 kg + 47 175 kg  
= 108 125 kg (134,370 lb + 104,000 lb = 238,370 lb)

# 631 Wheel Tractor-Scraper Specifications

## Rimpull-Speed-Gradeability Curves

### USE OF RIMPULL-SPEED-GRADEABILITY CURVES

The following explanation applies to Rimpull-Speed-Gradeability curves for wheel tractor-scraper, construction and mining trucks/tractors, and articulated trucks.

Maximum speed attainable, gear range, and available rimpull can be determined from curves on the following pages when machine weight and total effective grade (or total resistance) are known.

**Rimpull is the force** (in kg, lb, or kN) available between the tire and the ground to propel the machine (limited by traction).

**Weight** is defined as gross machine weight (kg or lb)  
= machine + payload

**Total effective grade (or total resistance)** is grade resistance plus rolling resistance expressed as percent grade.

Grade is measured or estimated.

Rolling resistance is estimated (see tables section for typical values).

10 kg/metric ton (20 lb/U.S. ton) = 1% adverse grade

*Example:*

**With a 6% grade and a rolling resistance of 40 kg/metric ton (80 lb/U.S. ton), find total resistance.**

Rolling resistance =  $40 \text{ kg/t} \div 10 = 4\%$  effective grade  
(English:  $80 \text{ lb} \div 20 = 4\%$ )

Total resistance = 4% rolling + 6% grade = 10%

### Altitude Derating

Rimpull force and speed must be derated for altitude similar to flywheel horsepower. The percentage loss in rimpull force approximately corresponds to the percentage loss in flywheel horsepower. See tables section for altitude derations.

### Rimpull-Speed-Gradeability

To determine gradeability performance: Read from gross weight down to the % of total resistance. [Total resistance equals actual % grade plus 1% for each 10 kg/metric ton (20 lb/U.S. ton) of rolling resistance.]

From this weight-resistance point, read horizontally to the curve with the highest obtainable speed range, then down to the maximum speed. Usable rimpull depends upon traction and weight on drive wheels.

#### Example Problem:

**A 631 with an estimated payload of 37 013 kg (81,600 lb) is operating on a total effective grade of 10%. Find the available rimpull and maximum attainable speed.**

Empty weight + payload = gross weight

$47\,628 \text{ kg} + 37\,013 \text{ kg} = 84\,641 \text{ kg}$

$(105,002 \text{ lb} + 81,600 \text{ lb} = 186,602 \text{ lb})$

**Solution:** Using graph on the next page, read from 84 641 kg (186,602 lb) (point A) on top of gross weight scale down the line to the intersection of the 10% total resistance line (point B).

Go across horizontally from B to the rimpull scale on the left (point D). This gives the required rimpull: 7756 kg (17,100 lb).

Where the line cuts the speed curve (point C), read down vertically (point E) to obtain the maximum speed attainable for the 10% effective grade: 12.9 km/h (8 mph).

**Answer:** The machine will climb the 10% effective grade at a maximum speed of 12.9 km/h (8 mph) in 4th gear. Available rimpull is 7756 kg (17,100 lb).

# 631 Wheel Tractor-Scraper Specifications

## Rimpull-Speed-Gradeability Curves

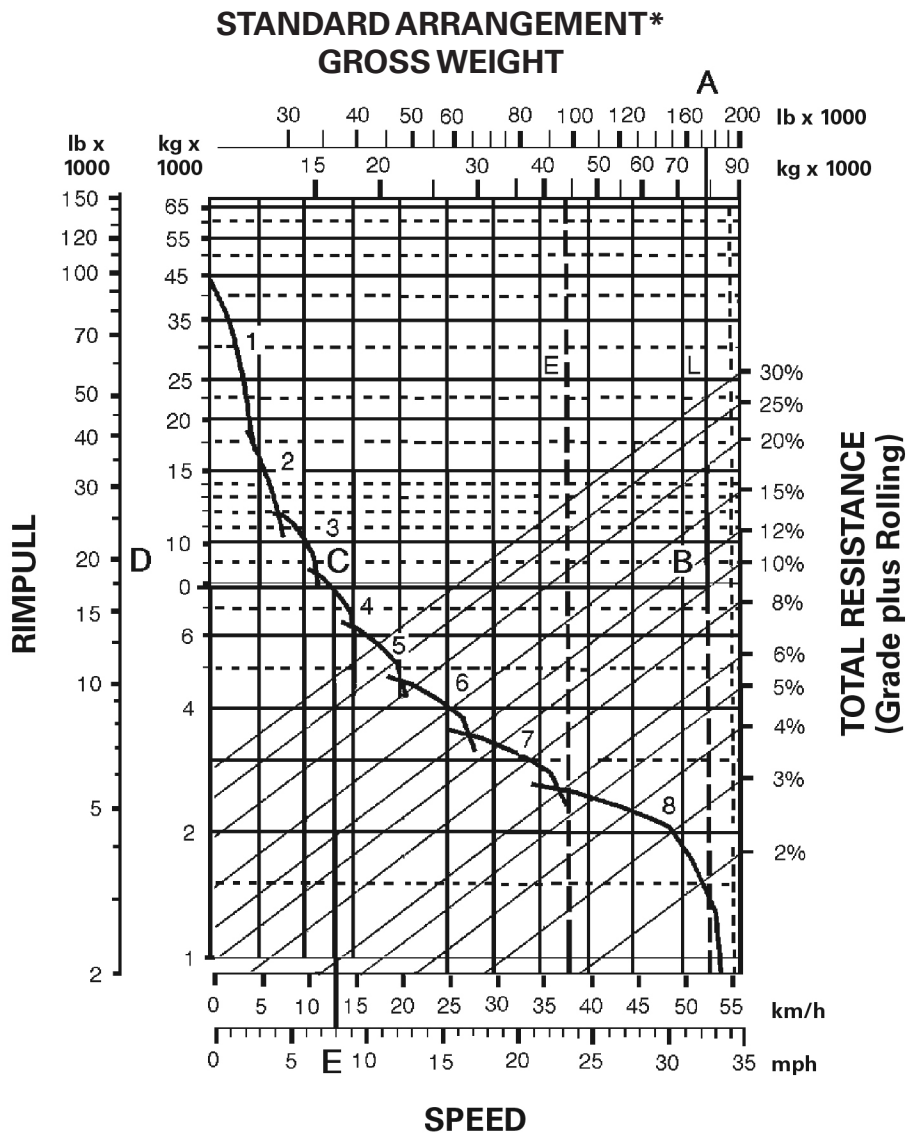

**KEY**

- 1 — 1st Gear Torque Converter Drive
- 2 — 2nd Gear Torque Converter Drive
- 3 — 3rd Gear Direct Drive
- 4 — 4th Gear Direct Drive
- 5 — 5th Gear Direct Drive
- 6 — 6th Gear Direct Drive
- 7 — 7th Gear Direct Drive
- 8 — 8th Gear Direct Drive

**KEY**

- A — Loaded 84 641 kg (186,602 lb)
- B — Intersection with 10% total resistance line
- C — Intersection with rimpull curve (4th gear)
- D — Required rimpull 7756 kg (17,100 lb)
- E — Speed 12.9 km/h (8 mph)

\*At sea level

# 631 Wheel Tractor-Scraper Specifications

## Retarder Curves

**Solution:** Using the retarder curve below, read from 108 125 kg (238,370 lb) (point A) on top of gross weight scale down the line to the intersection of the 10% effective grade line (point B).

Go across horizontally from point B to the intersection of the retarder curve (point C). Point C intersects at the 5 (5th gear) range.

Where point C intersects the retarder curve, read down vertically to point D on the bottom scale to obtain the constant speed: 21.7 km/h (13.5 mph).

**Answer:** The 631 will descend the slope at 21.7 km/h (13.5 mph) in 5th gear. Travel time is 1.68 minutes.

$$\frac{610 \text{ m}}{363 \text{ m/min}} = 1.68 \text{ min}$$

\* (mph x 88 = F.P.M.)

$$\frac{2,000 \text{ ft}}{13.5 \text{ mph} \times 88^*} = 1.68 \text{ min}$$

**Note:** The basic distance-speed-time formula is  $60 D \div S = T$  (or “60 D Street”), where 60 is minutes, D is distance, S is speed, and T is time. In the above problem,  $60 \times 610 \text{ m} \div 21.7 \text{ km/h} \times 1000 = T$ .

$$\frac{60 \times 610}{21.7 \times 1000} = T = (1.68)$$

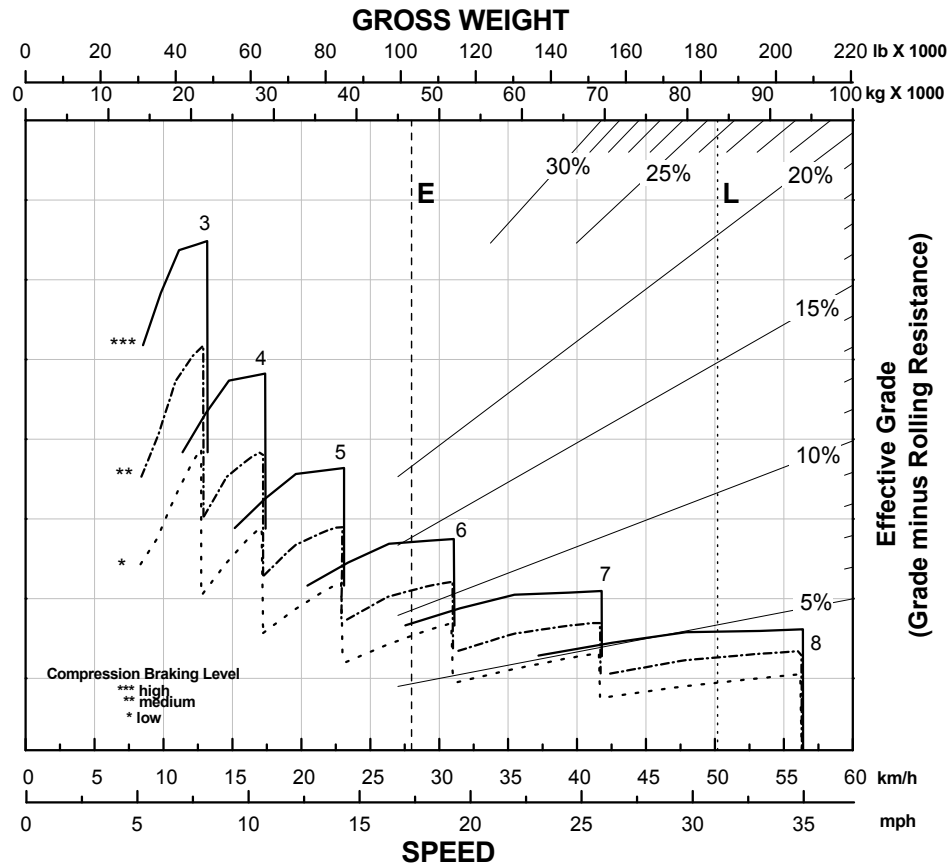

### KEY

- 3 — 3rd Gear Direct Drive
- 4 — 4th Gear Direct Drive
- 5 — 5th Gear Direct Drive
- 6 — 6th Gear Direct Drive
- 7 — 7th Gear Direct Drive
- 8 — 8th Gear Direct Drive

### KEY

- A — Loaded 108 125 kg (238,370 lb)
- B — Intersection with 10% effective grade line
- C — Intersection with retarder curve (5th gear)
- D — Constant speed 21.7 km/h (13.5 mph)



# 631 Wheel Tractor-Scraper Specifications

## Rimpull-Speed-Gradeability – 33.25R29 Tires

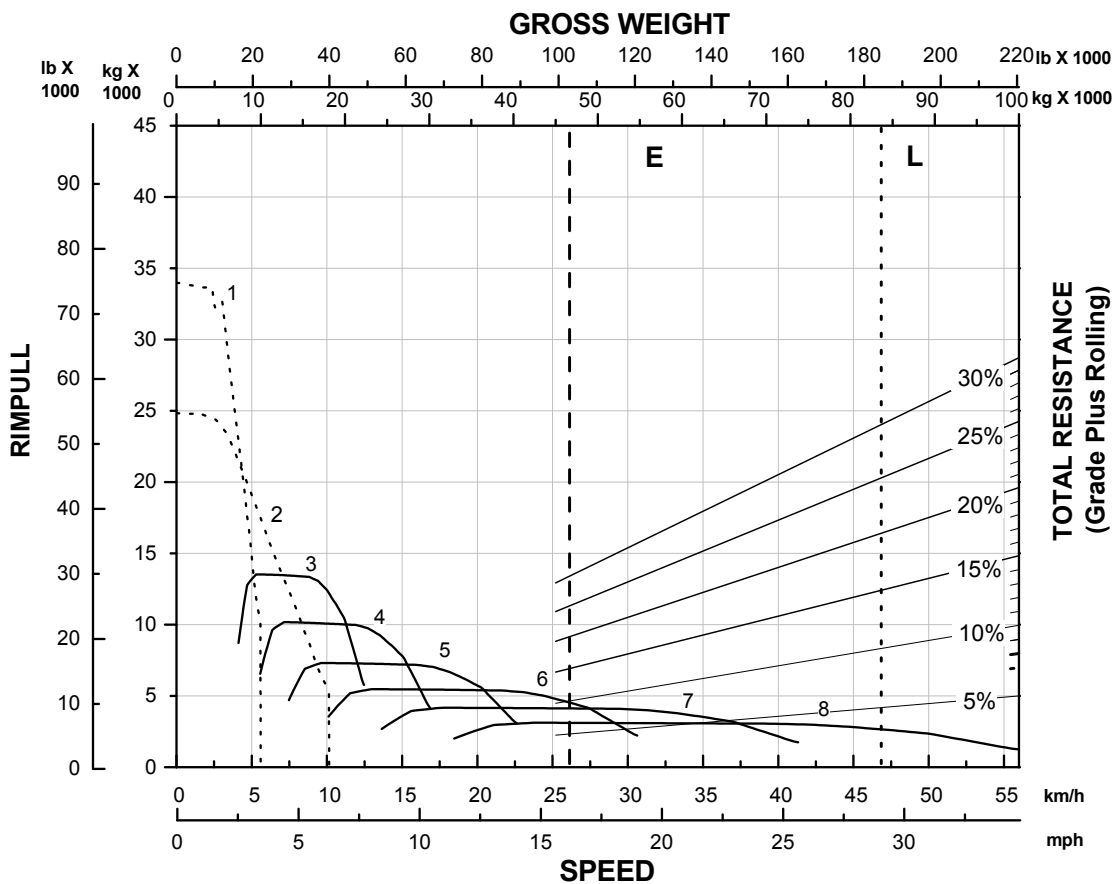

### KEY

- 1 – 1st Gear Torque Converter Drive
- 2 – 2nd Gear Torque Converter Drive
- 3 – 3rd Gear Direct Drive
- 4 – 4th Gear Direct Drive
- 5 – 5th Gear Direct Drive
- 6 – 6th Gear Direct Drive
- 7 – 7th Gear Direct Drive
- 8 – 8th Gear Direct Drive

### KEY

- E – Empty 35 808 kg (78,943 lb)
- L – Loaded 61 935 kg (136,553 lb)

# 631 Wheel Tractor-Scraper Specifications

## Standard Equipment

Standard equipment may vary. Consult your Cat® dealer for details.

	Standard	Optional		Standard	Optional
<b>POWERTRAIN – TRACTOR</b>			<b>OPERATOR ENVIRONMENT – TRACTOR (CONTINUED)</b>		
Cat C13 engine with Mechanically Actuated Electronic Unit Injection (MEUI™)	✓		T-handle implement control	✓	
Cat engine brake	✓		Mirror, rearview	✓	
Electric start, 24V	✓		Radio ready	✓	
Air cleaner, dry type with precleaner	✓		Rollover protective structure (ROPS)/falling objects protective structure (FOPS) cab, pressurized	✓	
Fan, hydraulic	✓		Keypad switches: throttle lock, wipers/washers, hazard lights, retarding level select, work lights on/off, information mode on messenger display	✓	
Ground level engine shutdown	✓		Safety tab rocker switches	✓	
Radiator, aluminum unit core, 9 fins per inch	✓		Seat belt, static two-piece	✓	
Guard, crankcase	✓		Seat – Cat advanced ride management (ARM), Cat Comfort Series III, rotates 30 degrees	✓	
Starting aid, ether	✓		Steering wheel, tilt, telescoping, padded	✓	
Braking system: primary and secondary, wet disc, hydraulic; parking, hydraulic-released, spring-applied	✓		Windows, right side emergency egress	✓	
Transmission: 8-speed planetary power shift, electronic clutch pressure control (ECPC), advanced productivity electronic control strategy (APECS); software, programmable top gear selection, transmission hold, differential lock, transmission guard, ground speed control, machine speed limit	✓		Windows, sliding	✓	
<b>POWERTRAIN – SCRAPER</b>			Windows, laminated, zipped in	✓	
Braking system: primary and secondary, wet disc, hydraulic	✓		Windshield wipers, front and rear windows, includes washers	✓	
<b>ELECTRICAL – TRACTOR</b>			Door lock	✓	
Alternator, 115 amp	✓		Messenger display	✓	
Batteries (4), 12V, 1,000 CCA, maintenance free, high output	✓		Gauges, warnings include: coolant temperature, engine oil temperature, hydraulic oil temperature, diesel particulate filter (DPF) temperature, fuel level, park brake, implement lockout, brake system, regeneration required, throttle lock, system voltage, secondary steering, bail down, ejector auto, differential lock, apron float, transmission hold, cushion hitch, high beam lights, action lamp, engine speed – rpm, gear selection, diesel exhaust fluid (DEF)* fill level	✓	
Electrical system, 24V	✓		<b>FLUIDS</b>		
LED lights	✓		Extended life coolant to -37° C (-34° F)	✓	
Starting/charging receptacle	✓		<b>OTHER STANDARD EQUIPMENT – TRACTOR</b>		
<b>ELECTRICAL – SCRAPER</b>			Advanced cushion hitch	✓	
Alarm, backup	✓		Accumulators (cushion hitch and brake) with Canadian registration number (CRN)	✓	
Lighting system: LED low beam, high beam, and work lights	✓		Fenders, non-metallic	✓	
<b>OPERATOR ENVIRONMENT – TRACTOR</b>			Heater, engine coolant 120V	✓	
HVAC system, heat, AC, defrost	✓		Tow pin, front	✓	
Thermostat control of HVAC system	✓		Vandalism locks	✓	
Coat hook	✓		<b>OTHER STANDARD EQUIPMENT – SCRAPER</b>		
Lunchbox platform with holding strap	✓		Bowl: 18.4 m <sup>3</sup> (24 yd <sup>3</sup> ) – heaped, 14.1 m <sup>3</sup> (18.4 yd <sup>3</sup> ) – struck	✓	
Diagnostic connection (2)	✓		Vandalism locks	✓	
12V power ports (2)	✓		Hydraulic position sensing cylinders (bowl lift and apron)	✓	
Differential lock	✓				
Dome courtesy light	✓				
Horn, electric	✓				

\*When equipped

# 631 Wheel Tractor-Scraper Specifications

## Standard and Optional Attachments

Standard and optional attachments may vary. Consult your Cat dealer for details.

	Standard	Optional
<b>STEERING ARRANGEMENTS</b>		
Secondary steering (electrically powered)		✓
<b>INTEGRATED TECHNOLOGIES</b>		
Sequence Assist CPM – Payload Estimator and Cat Production Measurement		✓
Load assist		✓
Cat production measurement	✓	
<b>SERVICE INSTRUCTIONS</b>		
Film arrangement – U.S. (ANSI)		✓
Film arrangement – International (ISO)		✓

	Standard	Optional
<b>OTHER ATTACHMENTS</b>		
Camera arrangement – work area vision system (WAVS)		✓
Steering lock – external	✓	
Cab beacon		✓
Air horn		✓
Fender, scraper		✓
Guard, overflow	✓	
Year of manufacture plate		✓
Fast-fill fuel tank	✓	
Cold start		✓

# 631 Environmental Declaration

The following information applies to the machine at the time of final manufacture as configured for sale in the regions covered in this document. The content of this declaration is valid as of the date issued; however, content related to machine features and specifications are subject to change without notice. For additional information, please see the machine's Operation and Maintenance Manual.

For more information on sustainability in action and our progress, please visit <https://www.caterpillar.com/en/company/sustainability>.

## Engine

- The Cat® C13 engine is available in configurations that meet U.S. EPA Tier 4 Final and EU Stage V emission standards or equivalent to U.S. EPA Tier 2, or equivalent to U.S. EPA Tier 3 and EU Stage IIIA.
- Cat U.S. EPA Tier 4 Final and EU Stage V diesel engines are required to use ULSD (ultra-low sulfur diesel fuel with 15 ppm of sulfur or less) or ULSD blended with the following lower-carbon intensity fuels\*\*\* up to:
  - ✓ 20% biodiesel FAME (fatty acid methyl ester)\*
  - ✓ 100% renewable diesel, HVO (hydrotreated vegetable oil) and GTL (gas-to-liquid) fuels
- Cat engines meeting equivalent to U.S. EPA Tier 2, or equivalent to U.S. EPA Tier 3 and EU Stage IIIA, are compatible with diesel fuel blended with the following lower-carbon intensity fuels\*\*\* up to:
  - ✓ 100% biodiesel FAME (fatty acid methyl ester)\*\*
  - ✓ 100% renewable diesel, HVO (hydrotreated vegetable oil) and GTL (gas-to-liquid) fuels

Refer to guidelines for successful application. Please consult your Cat dealer or "Caterpillar Machine Fluids Recommendations" (SEBU6250) for details.

*\*\*Engines with no aftertreatment devices can use higher blends, up to 100% biodiesel.*

*\*\*For use of blends higher than 20% biodiesel, consult your Cat dealer.*

*\*\*\*Tailpipe greenhouse gas emissions from lower-carbon intensity fuels are essentially the same as traditional fuels.*

## Air Conditioning System

- The air conditioning system on this machine contains the fluorinated greenhouse gas refrigerant R134a (Global Warming Potential = 1430). The system contains 1.9 kg (4.2 lb) of refrigerant which has a CO<sub>2</sub> equivalent of 2.71 metric tonnes (2.674 tons).

## Paint

- Based on best available knowledge, the maximum allowable concentration, measured in parts per million (PPM), of the following heavy metals in paint are:
  - Barium < 0.01%
  - Cadmium < 0.01%
  - Chromium < 0.01%
  - Lead < 0.01%

## Sound Performance

With cooling fan speed at maximum value:

Operator Sound Pressure Level (ISO 6396:2008) – 76 dB(A)

Exterior Sound Power Level (ISO 6395:2008) – 116.5 dB(A)

- When properly installed and maintained, the cab offered by Caterpillar, when tested with doors and windows closed.
- Hearing protection may be needed when operating with an open operator station and cab (when not properly maintained or doors/windows open) for extended periods or in a noisy environment.

## Oils and Fluids

- Caterpillar factory fills with ethylene glycol coolants. Cat Diesel Engine Antifreeze/Coolant (DEAC) and Cat Extended Life Coolant (ELC) can be recycled. Consult your Cat dealer for more information.
- Cat Bio HYDO Advanced is an EU Ecolabel approved biodegradable hydraulic oil.
- Additional fluids are likely to be present, please consult the Operations and Maintenance Manual or the Application and Installation guide for complete fluid recommendations and maintenance intervals.

## Features and Technology

- The following features and technology contribute to fuel savings and/or carbon reduction. Features may vary. Consult your Cat dealer for details.
  - Ground speed control helps lower fuel burn by allowing the operator to set the desired top speed and the machine will find the optimal gear for the engine and transmission
  - Optional load assist helps shorten the learning curve for inexperienced operators
  - Advanced productivity electronic control system (APECS) allows the engines and transmission to communicate on a high level to better utilize the power and torque
  - Optional Cat Grade Control helps operators of all skill levels avoid costly rework, wasteful fuel burn, and greenhouse gas emissions to execute the design plan with greater speed and accuracy
  - Reduced chain wear with the enhanced elevator drive sprocket
  - Decreased sprocket wear, chain wear, and chain jumping with improved scissor-style chain
  - On-demand hydraulic fan helps reduce fuel consumption and underhood heat for longer component life
  - Improve jobsite efficiency with lower operating costs with Product Link™ and VisionLink® insights

For more complete information on Cat products, dealer services, and industry solutions, visit us on the web at [www.cat.com](http://www.cat.com).

Materials and specifications are subject to change without notice. Featured machines in photos may include additional equipment. See your Cat dealer for available options.

© 2023 Caterpillar. All Rights Reserved. CAT, CATERPILLAR, LET'S DO THE WORK, their respective logos, Product Link, MEUI, "Caterpillar Corporate Yellow", the "Power Edge" and Cat "Modern Hex" trade dress as well as corporate and product identity used herein, are trademarks of Caterpillar and may not be used without permission.

VisionLink is a trademark of Caterpillar Inc., registered in the United States and in other countries.

AEXQ3593-00 (06-2023)  
Build Number: 11A  
(Global)

