



# 315 GC

## Hydraulic Excavator

# Technical Specifications

Configurations and features may vary by region. Please consult your Cat® dealer for availability in your area.

## Table of Contents

<b>Specifications</b> .....	<b>2</b>
Engine .....	2
Swing Mechanism .....	2
Weights .....	2
Track .....	2
Drive .....	2
Hydraulic System .....	2
Service Refill Capacities .....	2
Standards .....	2
Sound Performance .....	2
Air Conditioning System .....	2
Operating Weights and Ground Pressures .....	3
Major Component Weights .....	4
Dimensions .....	5
Working Ranges and Forces .....	7
Blade Working Ranges .....	8
Reach Boom Lift Capacities .....	9
Bucket Specifications and Compatibility .....	17
Attachments Offering Guide .....	18
<b>Standard and Optional Equipment</b> .....	<b>19</b>
<b>Dealer Installed Kits and Attachments</b> .....	<b>21</b>
<b>315 GC Environmental Declaration</b> .....	<b>22</b>

# 315 GC Hydraulic Excavator Specifications

## Engine

Engine Model	Cat® C3.6	
Net Power		
ISO 9249	73.3 kW	98 hp
ISO 9249 (DIN)	100 hp (metric)	
Engine Power		
ISO 14396	74.4 kW	100 hp
ISO 14396 (DIN)	101 hp (metric)	
Bore	98 mm	4 in
Stroke	120 mm	5 in
Displacement	3.6 L	220 in <sup>3</sup>
Biodiesel Capability	Up to B20 <sup>(1)</sup>	

- Emits equivalent to U.S. EPA Tier 3.
- No engine power derating required below 3000 m (9,840 ft) altitude.
- Advertised power is tested per the specified standard in effect at the time of manufacture.
- Net power advertised is the power available at the flywheel when the engine is equipped with fan, air intake system, exhaust system and alternator.
- Engine speed at 2,200 rpm.

<sup>(1)</sup>Cat engines are compatible with diesel fuel blended with the following lower-carbon intensity fuels\*\* up to:

- ✓ 100% biodiesel FAME (fatty acid methyl ester)\*
- ✓ 100% renewable diesel, HVO (hydrotreated vegetable oil) and GTL (gas-to-liquid) fuels

Refer to guidelines for successful application. Please consult your Cat dealer or “Caterpillar Machine Fluids Recommendations” (SEBU6250) for details.

\*For use of blends higher than 20% biodiesel, consult your Cat dealer.

\*\*Lower-carbon intensity fuels do not significantly reduce GHGs at the tailpipe.

## Swing Mechanism

Swing Speed	11.5 rpm	
Maximum Swing Torque	35 kN·m	25,815 lbf·ft

## Weights

Operating Weight	14 700 kg	32,400 lb
------------------	-----------	-----------

- Long undercarriage, Reach boom, R2.5 (8'2") stick, GD 0.53 m<sup>2</sup> (0.69 yd<sup>3</sup>) bucket, 500 mm (20") triple grouser shoes and 3.83 mt (8,440 lb).

## Track

Optional Track Shoes Width	500 mm	20 in
Optional Track Shoes Width	600 mm	24 in
Optional Track Shoes Width	700 mm	28 in
Number of Shoes (each side)	46	
Number of Track Rollers (each side)	7	
Number of Carrier Rollers (each side)	1	

## Drive

Gradeability	35°/70%	
Maximum Travel Speed	5.4 km/h	3.4 mph
Maximum Drawbar Pull	117 kN	26,303 lbf

## Hydraulic System

Main System – Maximum Flow – Implement	247 L/min	65 gal/min
Maximum Pressure – Equipment – Normal	35 000 kPa	5,075 psi
Maximum Pressure – Travel	35 000 kPa	5,075 psi
Maximum Pressure – Swing	26 000 kPa	3,770 psi
Boom Cylinder – Bore	105 mm	4 in
Boom Cylinder – Stroke	1023 mm	40 in
Stick Cylinder – Bore	115 mm	5 in
Stick Cylinder – Stroke	1147 mm	45 in
Bucket Cylinder – Bore	95 mm	4 in
Bucket Cylinder – Stroke	939 mm	37 in

## Service Refill Capacities

Fuel Tank Capacity	187 L	49.4 gal
Cooling System	15 L	4.0 gal
Engine Oil	8 L	2.1 gal
Final Drive (each)	3 L	0.8 gal
Hydraulic System (including tank)	85 L	22.5 gal
Hydraulic Tank	72 L	19.0 gal

## Standards

Brakes	ISO 10265:2008
Cab/Rollover Protective Structure (ROPS)	ISO 12117-2:2008
Cab/Operator Protective Guards (OPG) (Optional)	ISO 10262:1998 (Level II)

## Sound Performance

ISO 6395:2008 (external)	101 dB(A)
ISO 6396:2008 (inside cab)	71 dB(A)

- Hearing protection may be needed when operating with an open operator station and cab (when not properly maintained or doors/windows open) for extended periods or in a noisy environment.

## Air Conditioning System

The air conditioning system on this machine contains the fluorinated greenhouse gas refrigerant R134a (Global Warming Potential = 1430). The system contains 0.8 kg of refrigerant which has a CO<sub>2</sub> equivalent of 1.144 metric tonnes.

# 315 GC Hydraulic Excavator Specifications

## Operating Weights and Ground Pressures

	500 mm (20") Triple Grouser Shoes		500 mm (20") Triple Grouser Shoes with Rubber Pad		500 mm (20") Rubber Shoes	
	Weight	Ground Pressure	Weight	Ground Pressure	Weight	Ground Pressure
	kg (lb)	kPa (psi)	kg (lb)	kPa (psi)	kg (lb)	kPa (psi)
<b>Base Machine Configurations</b>						
<b>Base Frame with Track Rollers and Carrier Rollers</b>						
<b>Base Machine with 3.83 mt (8,440 lb) Counterweight and Long Undercarriage</b>						
Reach Boom + R2.5 (8'2") Stick + 0.53 m <sup>3</sup> (0.69 yd <sup>3</sup> ) GD Bucket	14 700 (32,400)	43.8 (6.4)	15 300 (33,700)	45.6 (6.6)	14 900 (32,800)	37.0 (5.4)
Reach Boom + R3.0 (9'10") Stick + 0.53 m <sup>3</sup> (0.69 yd <sup>3</sup> ) GD Bucket	14 800 (32,600)	44.1 (6.4)	15 300 (33,700)	45.6 (6.6)	14 900 (32,800)	37.0 (5.4)
Reach Boom + R2.5 (8'2") Stick + 0.53 m <sup>3</sup> (0.69 yd <sup>3</sup> ) GD Bucket + Blade	15 500 (34,200)	46.2 (6.7)	16 000 (35,300)	47.7 (6.9)	15 600 (34,400)	38.8 (5.6)
Reach Boom + R3.0 (9'10") Stick + 0.53 m <sup>3</sup> (0.69 yd <sup>3</sup> ) GD Bucket + Blade	15 500 (34,200)	46.2 (6.7)	16 000 (35,300)	47.7 (6.9)	15 700 (34,600)	39.0 (5.7)

All operating weights include a 90% fuel tank with 75 kg (165 lb) operator.

	600 mm (24") Rubber Shoes		600 mm (24") Triple Grouser Shoes		700 mm (28") Triple Grouser Shoes	
	Weight	Ground Pressure	Weight	Ground Pressure	Weight	Ground Pressure
	kg (lb)	kPa (psi)	kg (lb)	kPa (psi)	kg (lb)	kPa (psi)
<b>Base Machine Configurations</b>						
<b>Base Frame with Track Rollers and Carrier Rollers</b>						
<b>Base Machine with 3.83 mt (8,440 lb) Counterweight and Long Undercarriage</b>						
Reach Boom + R2.5 (8'2") Stick + 0.53 m <sup>3</sup> (0.69 yd <sup>3</sup> ) GD Bucket	15 200 (33,400)	27.7 (5.5)	15 000 (33,100)	29.0 (4.2)	15 200 (33,500)	32.4 (4.7)
Reach Boom + R3.0 (9'10") Stick + 0.53 m <sup>3</sup> (0.69 yd <sup>3</sup> ) GD Bucket	15 300 (33,600)	37.9 (5.5)	15 100 (33,300)	29.2 (4.2)	15 300 (33,700)	32.6 (4.7)
Reach Boom + R2.5 (8'2") Stick + 0.53 m <sup>3</sup> (0.69 yd <sup>3</sup> ) GD Bucket + Blade	16 000 (35,200)	39.6 (5.7)	15 800 (34,800)	30.6 (4.4)	—	—
Reach Boom + R3.0 (9'10") Stick + 0.53 m <sup>3</sup> (0.69 yd <sup>3</sup> ) GD Bucket + Blade	16 100 (35,400)	39.9 (5.8)	15 900 (35,100)	30.8 (4.5)	—	—

All operating weights include a 90% fuel tank with 75 kg (165 lb) operator.

# 315 GC Hydraulic Excavator Specifications

## Major Component Weights

	kg	lb
Base Machine Weight: Base machine (with 3.83 mt [8,440 lb] counterweight, upper frame, long undercarriage – does not include boom, stick, bucket, boom cylinders, stick cylinders, bucket cylinders, tracks, blade, fuel tank, operator).		
With Long Undercarriage	10 660	23,500
With Long Undercarriage (blade compatible)	10 940	24,100
Track Shoes:		
500 mm (20") Triple Grouser Track Shoes	1540	3,390
500 mm (20") Triple Grouser Track Shoes with Rubber Pad	2050	4,520
500 mm (20") Rubber Shoes	1670	3,680
600 mm (24") Triple Grouser Track Shoes	1810	4,000
600 mm (24") Rubber Shoes	1970	4,340
700 mm (28") Triple Grouser Track Shoes with Additional Steps	2020	4,500
Two Boom Cylinders	240	530
Weight of 90% Fuel Tank and 75 kg (165 lb) Operator	210	460
Blades (without lines, cylinders, frame modifications):		
2500 mm (8'2") Blade for use with 500 mm (20") Track Shoes	440	960
2600 mm (8'6") Blade for use with 600 mm (24") Track Shoes	490	1,080
Counterweight:		
3830 kg (8,440 lb) Counterweight	3830	8,440
Swing Frame	1420	3,140
Undercarriages:		
Base Frame with GD Track Rollers and One Carrier Roller for Long Undercarriage	2620	5,770
Base Frame with GD Track Rollers and One Carrier Roller (blade compatible)	2900	6,400
Boom (including lines, pins, stick cylinder):		
Reach Boom 4.65 m (15'3")	1030	2,270
Sticks (including lines, pins, bucket cylinder, bucket linkage):		
Reach Stick R2.5 m (8'2")	590	1,310
Reach Stick R3.0 m (9'10")	650	1,440
Buckets (without linkage, with tips and side cutters):		
0.53 m <sup>3</sup> (0.69 yd <sup>3</sup> ) GD Bucket	460	1,010
0.65 m <sup>3</sup> (0.85 yd <sup>3</sup> ) GD Bucket	500	1,110
Quick Coupler:		
Pin Grabber Quick Coupler	210	470

# 315 GC Hydraulic Excavator Specifications

## Dimensions

All dimensions are approximate and may vary depending on bucket selection.

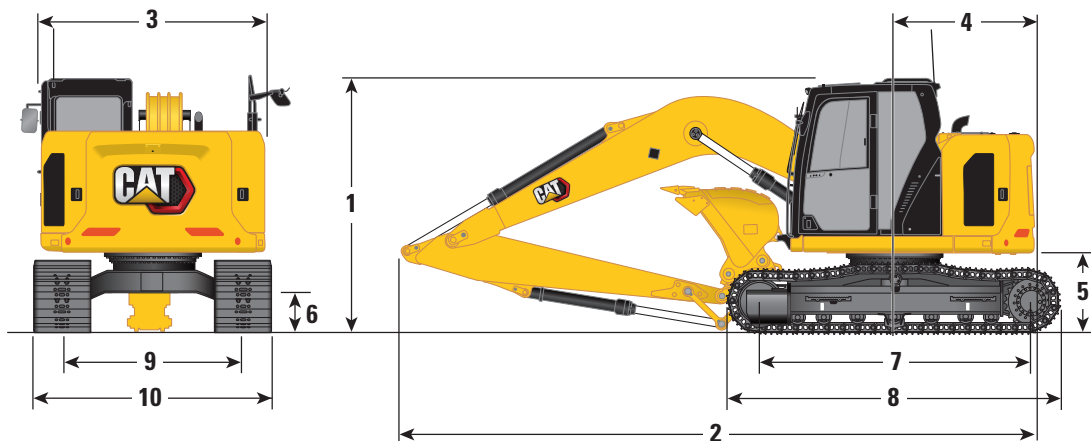

Boom Option	Reach Boom 4.65 m (15'3")			
	Stick Options		Reach Sticks	
	R2.5 (8'2")		R3.0 (9'10")	
<b>1 Machine Height:</b>				
Top of Cab Height	2810 mm	9'3"	2810 mm	9'3"
Top of OPG Height	2960 mm	9'9"	2960 mm	9'9"
Handrail Height	2860 mm	9'5"	2860 mm	9'5"
With Boom/Stick/Bucket Installed (with stick cylinder lines)	2890 mm	9'6"	3180 mm	10'5"
With Boom/Stick Installed (with stick cylinder lines)	2890 mm	9'6"	3180 mm	10'5"
With Boom Installed (with stick cylinder lines)	2410 mm	7'11"	2410 mm	7'11"
Machine Height (with 500 mm [20"] rubber shoes):				
Top of Cab Height	2860 mm	9'5"	2860 mm	9'5"
Top of OPG Height	3010 mm	9'11"	3010 mm	9'11"
Handrail Height	2910 mm	9'7"	2910 mm	9'7"
With Boom/Stick/Bucket Installed (with stick cylinder lines)	2940 mm	9'8"	3230 mm	10'7"
With Boom/Stick Installed (with stick cylinder lines)	2940 mm	9'8"	3230 mm	10'7"
With Boom Installed (with stick cylinder lines)	2460 mm	8'1"	2460 mm	8'1"
<b>2 Machine Length (without blade):</b>				
With Boom/Stick/Bucket Installed (with stick cylinder lines)	7440 mm	24'5"	7530 mm	24'8"
With Boom/Stick Installed (with stick cylinder lines)	7440 mm	24'5"	7530 mm	24'8"
With Boom Installed (with stick cylinder lines)	6640 mm	21'9"	6640 mm	21'9"
Machine Length (with blade, blade rear):				
With Boom/Stick/Bucket Installed (with stick cylinder lines)	8000 mm	26'3"	8090 mm	26'7"
With Boom/Stick Installed (with stick cylinder lines)	8000 mm	26'3"	8090 mm	26'7"
With Boom Installed (with stick cylinder lines)	7200 mm	23'7"	7200 mm	23'7"
Bucket Type	GD		GD	
Bucket Capacity	0.53 m <sup>3</sup>	0.69 yd <sup>3</sup>	0.53 m <sup>3</sup>	0.69 yd <sup>3</sup>
Bucket Tip Radius	1240 mm	4'1"	1240 mm	4'1"

# 315 GC Hydraulic Excavator Specifications

## Dimensions *(continued)*

All dimensions are approximate and may vary depending on bucket selection.

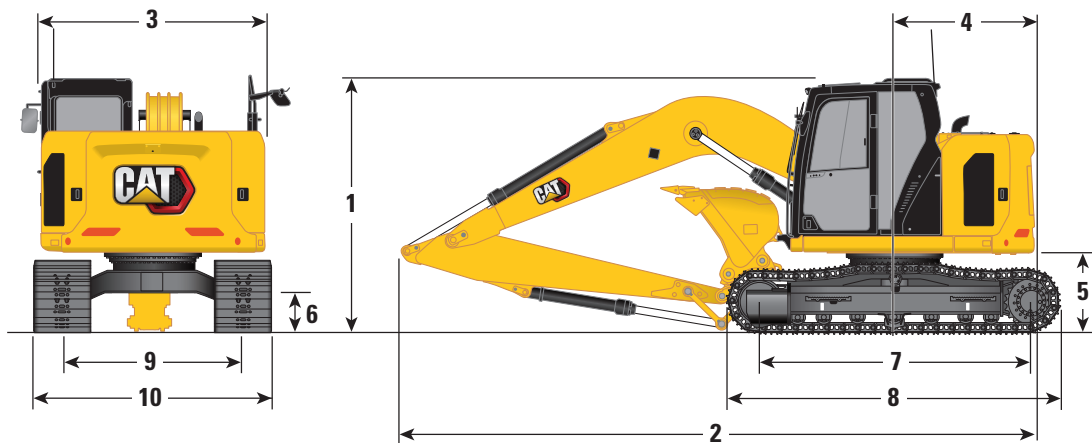

Boom Option	Reach Boom 4.65 m (15'3")			
	Reach Sticks		Reach Sticks	
Stick Options	R2.5 (8'2")		R3.0 (9'10")	
<b>3</b> Upperframe Width	2480 mm	8'2"	2480 mm	8'2"
<b>4</b> Tail Swing Radius	1570 mm	5'2"	1570 mm	5'2"
<b>5</b> Counterweight Clearance	880 mm	2'11"	880 mm	2'11"
<b>6</b> Ground Clearance	440 mm	1'5"	440 mm	1'5"
<b>7</b> Length to Center of Rollers	3040 mm	10'0"	3040 mm	10'0"
<b>8</b> Overall Track Length	3750 mm	12'4"	3750 mm	12'4"
<b>9</b> Track Gauge	1990 mm	6'6"	1990 mm	6'6"
<b>10</b> Track Width/Undercarriage Width:				
500 mm (20") Shoes	2490 mm	8'2"	2490 mm	8'2"
600 mm (24") Shoes	2590 mm	8'6"	2590 mm	8'6"
700 mm (28") Shoes (with steps)	2690 mm	8'10"	2690 mm	8'10"
Bucket Type	GD		GD	
Bucket Capacity	0.53 m <sup>3</sup>	0.69 yd <sup>3</sup>	0.53 m <sup>3</sup>	0.69 yd <sup>3</sup>
Bucket Tip Radius	1240 mm	4'1"	1240 mm	4'1"

# 315 GC Hydraulic Excavator Specifications

## Working Ranges and Forces

All dimensions are approximate and may vary depending on bucket selection.

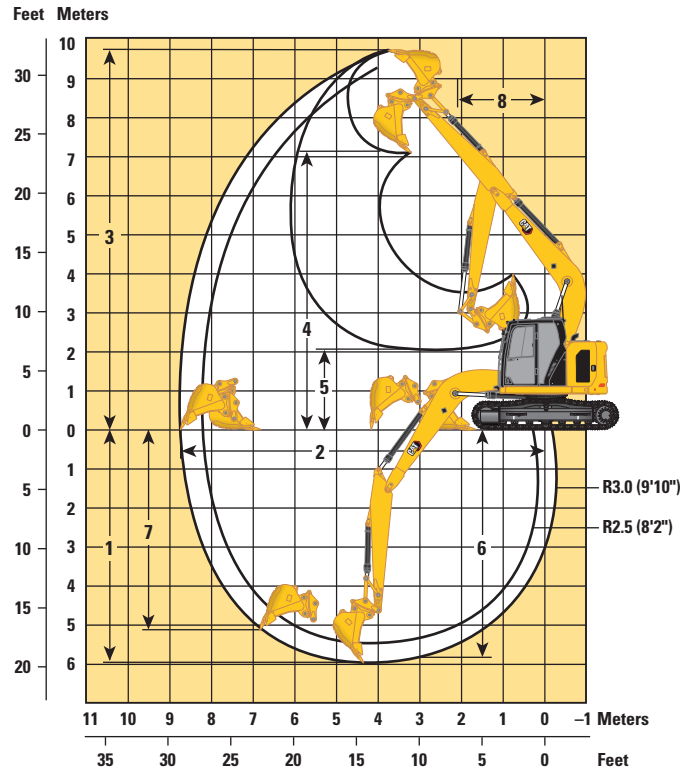

### Boom Option

**Reach Boom**  
4.65 m (15'3")

### Stick Options

**Reach Stick**

	R2.5 (8'2")		R3.0 (9'10")	
	GD	GD	GD	GD
1 Maximum Digging Depth	5490 mm	18'0"	5990 mm	19'8"
2 Maximum Reach at Ground Line	8230 mm	27'0"	8690 mm	28'6"
3 Maximum Cutting Height	9330 mm	30'7"	9690 mm	31'9"
4 Maximum Loading Height	6850 mm	22'6"	7220 mm	23'8"
5 Minimum Loading Height	2530 mm	8'4"	2080 mm	6'10"
6 Maximum Depth Cut for 2440 mm (8'0") Level Bottom	5280 mm	17'4"	5810 mm	19'1"
7 Maximum Vertical Wall Digging Depth	4740 mm	15'7"	5180 mm	17'0"
8 Minimum Working Equipment Radius	1990 mm	6'6"	2240 mm	7'4"
Bucket Digging Force (ISO)	98.45 kN	22,130 lbf	98.67 kN	22,180 lbf
Stick Digging Force (ISO)	66.68 kN	14,990 lbf	59.29 kN	13,330 lbf
Bucket Type	GD		GD	
Bucket Capacity	0.53 m <sup>3</sup>	0.69 yd <sup>3</sup>	0.53 m <sup>3</sup>	0.69 yd <sup>3</sup>
Bucket Tip Radius	1240 mm	4'1"	1240 mm	4'1"

# 315 GC Hydraulic Excavator Specifications

## Blade Working Ranges

All dimensions are approximate and may vary depending on bucket selection.

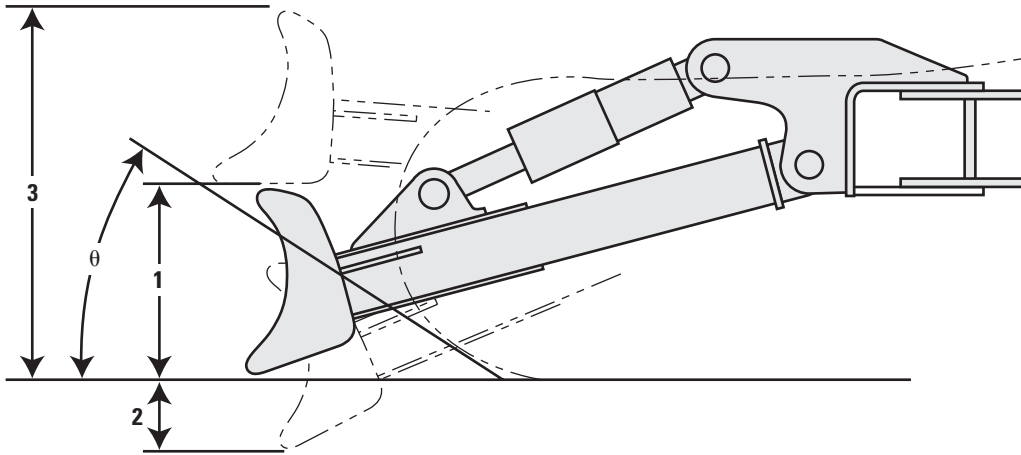

Blade Options	2500 mm (8'2")		2600 mm (8'6")	
	<b>1</b> Blade Height	616 mm	2'0"	616 mm
<b>2</b> Maximum Lowering Depth from Ground	550 mm	1'10"	550 mm	1'10"
<b>3</b> Maximum Raising Height above Ground	1018 mm	3'4"	1018 mm	3'4"
<b><math>\theta</math></b> Approach Angle	26°		26°	



# 315 GC Hydraulic Excavator Specifications

## Reach Boom Lift Capacities – Counterweight: 3.83 mt (8,440 lb) – without Bucket

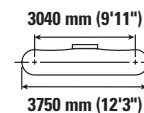
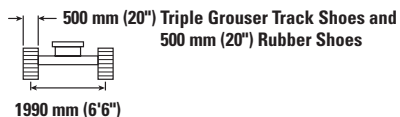

Reach mm ft/in	kg lb	1500 mm (5'0")		3000 mm (10'0")		4500 mm (15'0")		6000 mm (20'0")		315 GC Hydraulic Excavator		mm ft/in
		ISO 10567:2007	ISO 10567:2007	ISO 10567:2007	ISO 10567:2007	ISO 10567:2007	ISO 10567:2007	ISO 10567:2007	ISO 10567:2007	ISO 10567:2007	ISO 10567:2007	
7500 mm 25'0"	kg lb			*4350 *9,200	*4350 *9,200					*3250 *7,450	*3250 *7,450	3710 11'5"
6000 mm 20'0"	kg lb					*4050 *8,750	*4050 *8,750			*2600 *5,800	*2600 *5,800	5490 17'8"
4500 mm 15'0"	kg lb			*4150 *9,050	*4150 *9,050	*4500 *9,750	4050 8,700	*3700 *7,600	2550 5,500	*2450 *5,350	2250 5,050	6460 21'0"
3000 mm 10'0"	kg lb			*7400 *15,850	7400 15,450	*5150 *11,150	3850 8,250	3900 8,350	2500 5,350	*2450 *5,350	1950 4,300	6970 22'9"
1500 mm 5'0"	kg lb			*6800 *16,700	6400 13,800	*5850 12,600	3600 7,750	3800 8,100	2400 5,150	*2550 *5,600	1850 4,050	7130 23'4"
0 mm 0'0"	kg lb			*6250 *14,500	6100 13,150	5650 12,150	3400 7,350	3700 7,900	2300 4,950	*2850 *6,250	1900 4,150	6960 22'9"
-1500 mm -5'0"	kg lb	*4750 *10,700	*4750 *10,700	*7900 *17,150	6100 13,050	*5550 11,950	3350 7,200	3650 7,850	2250 4,900	3300 7,300	2100 4,550	6440 21'0"
-3000 mm -10'0"	kg lb	*7300 *15,650	*7300 *15,650	*5750 *12,350	*5750 *12,350	*4150 *8,750	3400 7,300			*2950 *6,400	2650 5,850	5460 17'9"

## Reach Boom Lift Capacities – Counterweight: 3.83 mt (8,440 lb) – without Bucket

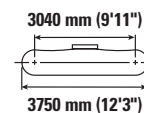
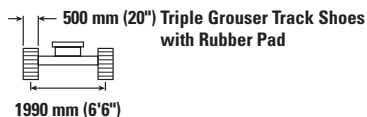
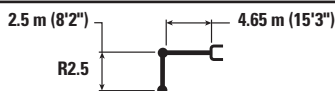

Reach mm ft/in	kg lb	1500 mm (5'0")		3000 mm (10'0")		4500 mm (15'0")		6000 mm (20'0")		315 GC Hydraulic Excavator		mm ft/in
		ISO 10567:2007	ISO 10567:2007	ISO 10567:2007	ISO 10567:2007	ISO 10567:2007	ISO 10567:2007	ISO 10567:2007	ISO 10567:2007	ISO 10567:2007	ISO 10567:2007	
7500 mm 25'0"	kg lb			*4350 *9,200	*4350 *9,200					*3250 *7,450	*3250 *7,450	3710 11'5"
6000 mm 20'0"	kg lb					*4050 *8,750	*4050 *8,750			*2600 *5,800	*2600 *5,800	5490 17'8"
4500 mm 15'0"	kg lb			*4150 *9,050	*4150 *9,050	*4500 *9,750	4200 9,000	*3700 *7,600	2650 5,700	*2450 *5,350	2350 5,200	6460 21'0"
3000 mm 10'0"	kg lb			*7400 *15,850	7400 15,450	*5150 *11,150	3950 8,550	4050 8,650	2600 5,550	*2450 *5,350	2050 4,500	6970 22'9"
1500 mm 5'0"	kg lb			*6800 *16,700	6650 14,250	*5850 *12,600	3700 8,000	3900 8,400	2500 5,300	*2550 *5,600	1950 4,200	7130 23'4"
0 mm 0'0"	kg lb			*6250 *14,500	*6250 13,600	5850 12,550	3550 7,600	3800 8,200	2400 5,150	*2850 *6,250	1950 4,300	6960 22'9"
-1500 mm -5'0"	kg lb	*4750 *10,700	*4750 *10,700	*7900 *17,150	6300 13,500	*5550 *11,950	3450 7,450	3800 8,150	2350 5,050	*3400 *7,450	2150 4,750	6440 21'0"
-3000 mm -10'0"	kg lb	*7300 *15,650	*7300 *15,650	*5750 *12,350	*5750 *12,350	*4150 *8,750	3500 7,550			*2950 *6,400	2750 6,050	5460 17'9"



ISO 10567:2007



\* Indicates that the load is limited by hydraulic lifting capacity rather than tipping load. The above loads are in compliance with hydraulic excavator lift capacity standard ISO 10567:2007.

They do not exceed 87% of hydraulic lifting capacity or 75% of tipping load. Weight of all lifting accessories must be deducted from the above lifting capacities. Lifting capacities are based on the machine standing on a firm, uniform supporting surface. The use of a work tool attachment point to handle/lift objects, could affect the machine lift performance.









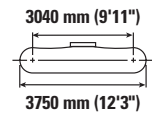
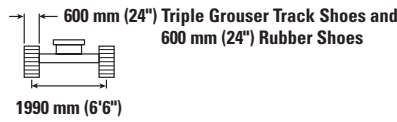
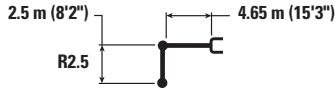

Lift capacity stays with ±5% for all available track shoes.

Always refer to the appropriate Operation and Maintenance Manual for specific product information.

# 315 GC Hydraulic Excavator Specifications









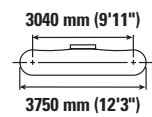
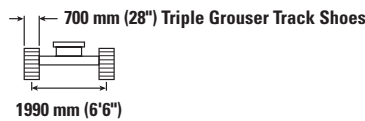
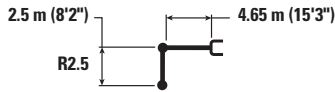

## Reach Boom Lift Capacities – Counterweight: 3.83 mt (8,440 lb) – without Bucket



		1500 mm (5'0")		3000 mm (10'0")		4500 mm (15'0")		6000 mm (20'0")				mm ft/in
												
7500 mm 25'0"	kg lb			*4350 *9,200	*4350 *9,200					*3250 *7,450	*3250 *7,450	3710 11'5"
6000 mm 20'0"	kg lb					*4050 *8,750	*4050 *8,750			*2600 *5,800	*2600 *5,800	5490 17'8"
4500 mm 15'0"	kg lb			*4150 *9,050	*4150 *9,050	*4500 *9,750	4100 8,850	*3700 *7,600	2600 5,600	*2450 *5,350	2300 5,100	6460 21'0"
3000 mm 10'0"	kg lb			*7400 *15,850	7300 15,700	*5150 *11,150	3900 8,400	3950 8,500	2550 5,450	*2450 *5,350	2000 4,400	6970 22'9"
1500 mm 5'0"	kg lb			*6800 *16,700	6550 14,050	*5850 *12,600	3650 7,850	3850 8,250	2450 5,250	*2550 *5,600	1900 4,150	7130 23'4"
0 mm 0'0"	kg lb			*6250 *14,500	6250 13,400	5750 12,350	3500 7,450	3750 8,050	2350 5,050	*2850 *6,250	1900 4,200	6960 22'9"
-1500 mm -5'0"	kg lb	*4750 *10,700	*4750 *10,700	*7900 *17,150	6200 13,300	*5550 *11,950	3400 7,300	3700 8,000	2300 5,000	*3400 *7,450	2100 4,650	6440 21'0"
-3000 mm -10'0"	kg lb	*7300 *15,650	*7300 *15,650	*5750 *12,350	*5750 *12,350	*4150 *8,750	3450 7,400			*2950 *6,400	2700 5,950	5460 17'9"

## Reach Boom Lift Capacities – Counterweight: 3.83 mt (8,440 lb) – without Bucket



		1500 mm (5'0")		3000 mm (10'0")		4500 mm (15'0")		6000 mm (20'0")				mm ft/in
												
7500 mm 25'0"	kg lb			*4350 *9,200	*4350 *9,200					*3250 *7,450	*3250 *7,450	3710 11'5"
6000 mm 20'0"	kg lb					*4050 *8,750	*4050 *8,750			*2600 *5,800	*2600 *5,800	5490 17'8"
4500 mm 15'0"	kg lb			*4150 *9,050	*4150 *9,050	*4500 *9,750	4150 8,950	*3700 *7,600	2650 5,650	*2450 *5,350	2350 5,200	6460 21'0"
3000 mm 10'0"	kg lb			*7400 *15,850	7350 *15,850	*5150 *11,150	3950 8,500	4000 8,650	2600 5,500	*2450 *5,350	2050 4,500	6970 22'9"
1500 mm 5'0"	kg lb			*6800 *16,700	6600 14,250	*5850 *12,600	3700 7,950	3900 8,400	2450 5,300	*2550 *5,600	1900 4,200	7130 23'4"
0 mm 0'0"	kg lb			*6250 *14,500	*6250 13,550	5850 12,550	3500 7,550	3800 8,200	2400 5,100	*2850 *6,250	1950 4,250	6960 22'9"
-1500 mm -5'0"	kg lb	*4750 *10,700	*4750 *10,700	*7900 *17,150	6300 13,500	*5550 *11,950	3450 7,400	3750 8,100	2350 5,050	*3400 *7,450	2150 4,750	6440 21'0"
-3000 mm -10'0"	kg lb	*7300 *15,650	*7300 *15,650	*5750 *12,350	*5750 *12,350	*4150 *8,750	3500 7,500			*2950 *6,400	2700 6,050	5460 17'9"



ISO 10567:2007



\* Indicates that the load is limited by hydraulic lifting capacity rather than tipping load. The above loads are in compliance with hydraulic excavator lift capacity standard ISO 10567:2007.

They do not exceed 87% of hydraulic lifting capacity or 75% of tipping load. Weight of all lifting accessories must be deducted from the above lifting capacities. Lifting capacities are based on the machine standing on a firm, uniform supporting surface. The use of a work tool attachment point to handle/lift objects, could affect the machine lift performance.

Lift capacity stays with ±5% for all available track shoes.

Always refer to the appropriate Operation and Maintenance Manual for specific product information.

# 315 GC Hydraulic Excavator Specifications

## Reach Boom Lift Capacities – Counterweight: 3.83 mt (8,440 lb) – without Bucket

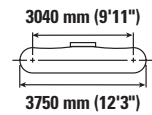
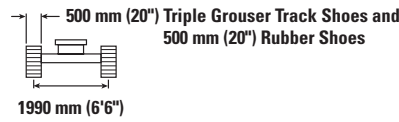
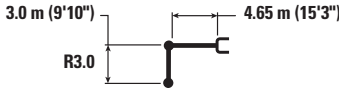

		1500 mm (5'0")		3000 mm (10'0")		4500 mm (15'0")		6000 mm (20'0")		7500 mm (25'0")		mm ft/in		
7500 mm 25'0"	kg lb					*2700	*2700					*2600 *5,850	*2600 *5,850	4540 14'3"
6000 mm 20'0"	kg lb					*3450 *7,550	*3450 *7,550	*2400	*2400			*2200 *4,850	*2200 *4,850	6070 19'8"
4500 mm 15'0"	kg lb					*3650 *7,950	*3650 *7,950	*3450 *7,400	2600 5,600			*2050 *4,500	2000 4,450	6960 22'8"
3000 mm 10'0"	kg lb			*5850 *12,100	*5850 *12,100	*4800 *10,350	3900 8,400	3950 8,400	2500 5,400			*2050 *4,500	1800 3,900	7440 24'4"
1500 mm 5'0"	kg lb			*8750 *18,800	6600 14,150	*5600 *12,050	3650 7,800	3800 8,150	2400 5,150	*2500 1700		*2150 *4,750	1700 3,700	7590 24'10"
0 mm 0'0"	kg lb			*7000 *16,150	6150 13,150	5650 12,150	3400 7,350	3650 7,900	2300 4,900			*2400 *5,250	1700 3,700	7430 24'4"
-1500 mm -5'0"	kg lb	*4300 *9,650	*4300 *9,650	*8500 *18,350	6000 12,900	5550 11,900	3300 7,100	3600 7,750	2250 4,800			*2850 *6,250	1850 4,050	6940 22'8"
-3000 mm -10'0"	kg lb	*7450 *16,700	*7450 *16,700	*6650 *14,350	6050 13,000	*4700 *10,000	3300 7,100	*3000	2250			*2950 *6,400	2250 4,950	6050 19'8"
-4500 mm -15'0"	kg lb			*3450 *7,050	*3450 *7,050							*2050 *4,250	*2050 *4,250	4490 14'4"

## Reach Boom Lift Capacities – Counterweight: 3.83 mt (8,440 lb) – without Bucket

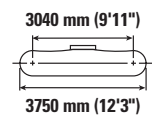
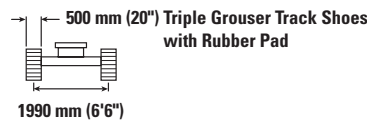
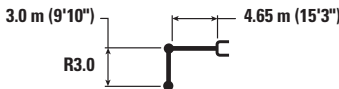

		1500 mm (5'0")		3000 mm (10'0")		4500 mm (15'0")		6000 mm (20'0")		7500 mm (25'0")		mm ft/in		
7500 mm 25'0"	kg lb					*2700	*2700					*2600 *5,850	*2600 *5,850	4540 14'3"
6000 mm 20'0"	kg lb					*3450 *7,550	*3450 *7,550	*2400	*2400			*2200 *4,850	*2200 *4,850	6070 19'8"
4500 mm 15'0"	kg lb					*3650 *7,950	*3650 *7,950	*3450 *7,400	2700 5,750			*2050 *4,500	*2050 *4,500	6960 22'8"
3000 mm 10'0"	kg lb			*5850 *12,100	*5850 *12,100	*4800 *10,350	4050 8,650	*3950 *8,550	2600 5,600			*2050 *4,500	1850 4,050	7440 24'4"
1500 mm 5'0"	kg lb			*8750 *18,800	6800 14,650	*5600 *12,050	3750 8,050	3900 8,400	2500 5,300	*2500 1750		*2150 *4,750	1750 3,800	7590 24'10"
0 mm 0'0"	kg lb			*7000 *16,150	6350 13,600	5850 12,550	3500 7,600	3800 8,150	2350 5,100			*2400 *5,250	1750 3,850	7430 24'4"
-1500 mm -5'0"	kg lb	*4300 *9,650	*4300 *9,650	*8500 *18,350	6250 13,350	5750 12,300	3400 7,350	3750 8,050	2300 4,950			*2850 *6,250	1900 4,200	6940 22'8"
-3000 mm -10'0"	kg lb	*7450 *16,700	*7450 *16,700	*6650 *14,350	6300 13,450	*4700 *10,000	3450 7,350	*3000	2350			*2950 *6,400	2300 5,150	6050 19'8"
-4500 mm -15'0"	kg lb			*3450 *7,050	*3450 *7,050							*2050 *4,250	*2050 *4,250	4490 14'4"



ISO 10567:2007



\* Indicates that the load is limited by hydraulic lifting capacity rather than tipping load. The above loads are in compliance with hydraulic excavator lift capacity standard ISO 10567:2007. They do not exceed 87% of hydraulic lifting capacity or 75% of tipping load. Weight of all lifting accessories must be deducted from the above lifting capacities. Lifting capacities are based on the machine standing on a firm, uniform supporting surface. The use of a work tool attachment point to handle/lift objects, could affect the machine lift performance.

Lift capacity stays with ±5% for all available track shoes.

Always refer to the appropriate Operation and Maintenance Manual for specific product information.

# 315 GC Hydraulic Excavator Specifications

## Reach Boom Lift Capacities – Counterweight: 3.83 mt (8,440 lb) – without Bucket

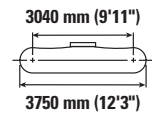
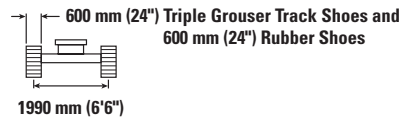
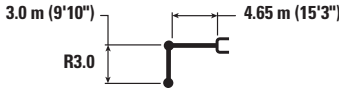

		1500 mm (5'0")		3000 mm (10'0")		4500 mm (15'0")		6000 mm (20'0")		7500 mm (25'0")		mm ft/in		
7500 mm 25'0"	kg lb					*2700	*2700					*2600 *5,850	*2600 *5,850	4540 14'3"
6000 mm 20'0"	kg lb					*3450 *7,550	*3450 *7,550	*2400	*2400			*2200 *4,850	*2200 *4,850	6070 19'8"
4500 mm 15'0"	kg lb					*3650 *7,950	*3650 *7,950	*3450 *7,400	2650 5,650			*2050 *4,500	2050 4,500	6960 22'8"
3000 mm 10'0"	kg lb			*5850 *12,100	*5850 *12,100	*4800 *10,350	3950 8,550	*3950 *8,550	2550 5,500			*2050 *4,500	1800 4,000	7440 24'4"
1500 mm 5'0"	kg lb			*8750 *18,800	6700 14,400	*5600 *12,050	3700 7,950	3850 8,300	2450 5,250	*2500	1750	*2150 *4,750	1700 3,750	7590 24'10"
0 mm 0'0"	kg lb			*7000 *16,150	6250 13,400	5750 12,350	3450 7,450	3750 8,050	2350 5,000			*2400 *5,250	1750 3,800	7430 24'4"
-1500 mm -5'0"	kg lb	*4300 *9,650	*4300 *9,650	*8500 *18,350	6150 13,150	5650 12,100	3350 7,250	3700 7,900	2300 4,900			*2850 *6,250	1900 4,150	6940 22'8"
-3000 mm -10'0"	kg lb	*7450 *16,700	*7450 *16,700	*6650 *14,350	6200 13,250	*4700 *10,000	3350 7,250	3000	2300			*2950 *6,400	2300 5,050	6050 19'8"
-4500 mm -15'0"	kg lb			*3450 *7,050	*3450 *7,050							*2050 *4,250	2050 4,250	4490 14'4"

## Reach Boom Lift Capacities – Counterweight: 3.83 mt (8,440 lb) – without Bucket

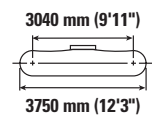
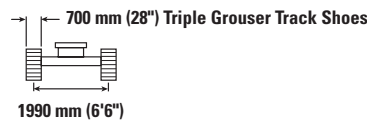
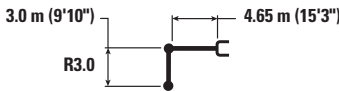

		1500 mm (5'0")		3000 mm (10'0")		4500 mm (15'0")		6000 mm (20'0")		7500 mm (25'0")		mm ft/in		
7500 mm 25'0"	kg lb					*2700	*2700					*2600 *5,850	*2600 *5,850	4540 14'3"
6000 mm 20'0"	kg lb					*3450 *7,550	*3450 *7,550	*2400	*2400			*2200 *4,850	*2200 *4,850	6070 19'8"
4500 mm 15'0"	kg lb					*3650 *7,950	*3650 *7,950	*3450 *7,400	2700 5,750			*2050 *4,500	*2050 *4,500	6960 22'8"
3000 mm 10'0"	kg lb			*5850 *12,100	*5850 *12,100	*4800 *10,350	4000 8,650	*3950 *8,550	2600 5,550			*2050 *4,500	1850 4,050	7440 24'4"
1500 mm 5'0"	kg lb			*8750 *18,800	6800 14,600	*5600 *12,050	3750 8,050	3900 8,400	2450 5,300	*2500	1750	*2150 *4,750	1750 3,800	7590 24'10"
0 mm 0'0"	kg lb			*7000 *16,150	6350 13,600	5850 12,550	3500 7,550	3800 8,150	2350 5,100			*2400 *5,250	1750 3,850	7430 24'4"
-1500 mm -5'0"	kg lb	*4300 *9,650	*4300 *9,650	*8500 *18,350	6200 13,300	5700 12,250	3400 7,350	3750 8,000	2300 4,950			*2850 *6,250	1900 4,200	6940 22'8"
-3000 mm -10'0"	kg lb	*7450 *16,700	*7450 *16,700	*6650 *14,350	6250 13,450	*4700 *10,000	3400 7,350	*3000	2350			*2950 *6,400	2300 5,100	6050 19'8"
-4500 mm -15'0"	kg lb			*3450 *7,050	*3450 *7,050							*2050 *4,250	*2050 *4,250	4490 14'4"



ISO 10567:2007



\* Indicates that the load is limited by hydraulic lifting capacity rather than tipping load. The above loads are in compliance with hydraulic excavator lift capacity standard ISO 10567:2007. They do not exceed 87% of hydraulic lifting capacity or 75% of tipping load. Weight of all lifting accessories must be deducted from the above lifting capacities. Lifting capacities are based on the machine standing on a firm, uniform supporting surface. The use of a work tool attachment point to handle/lift objects, could affect the machine lift performance.

Lift capacity stays with ±5% for all available track shoes.

Always refer to the appropriate Operation and Maintenance Manual for specific product information.

# 315 GC Hydraulic Excavator Specifications

## Reach Boom Lift Capacities – Counterweight: 3.83 mt (8,440 lb) – without Bucket – Blade Up

2500 mm (8'2") Blade

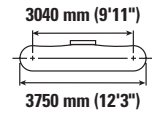
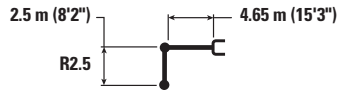

Reach Boom Lift Capacity	Unit	1500 mm (5'0")		3000 mm (10'0")		4500 mm (15'0")		6000 mm (20'0")		2500 mm (8'2") Blade		mm ft/in
		Hydraulic	Tipping	Hydraulic	Tipping	Hydraulic	Tipping	Hydraulic	Tipping	Hydraulic	Tipping	
7500 mm 25'0"	kg lb			*4350 *9,200	*4350 *9,200					*3250 *7,450	*3250 *7,450	3710 11'5"
6000 mm 20'0"	kg lb					*4050 *8,750	*4050 *8,750			*2600 *5,800	*2600 *5,800	5490 17'8"
4500 mm 15'0"	kg lb			*4150 *9,050	*4150 *9,050	*4500 *9,750	4250 9,100	*3700 *7,600	2700 5,750	*2450 *5,350	*2400 5,250	6460 21'0"
3000 mm 10'0"	kg lb			*7400 *15,850	*7400 *15,850	*5150 *11,150	4000 8,650	3900 8,350	2600 5,600	*2450 *5,350	2050 4,550	6970 22'9"
1500 mm 5'0"	kg lb			*6800 *16,700	6700 14,450	*5850 12,550	3750 8,100	3750 8,100	2500 5,400	*2550 *5,600	1950 4,300	7130 23'4"
0 mm 0'0"	kg lb			*6250 *14,500	*6250 13,800	5650 12,100	3600 7,700	3700 7,900	2400 5,200	*2850 *6,250	2000 4,350	6960 22'9"
-1500 mm -5'0"	kg lb	*4750 *10,700	*4750 *10,700	*7900 *17,150	6400 13,700	*5550 11,950	3500 7,550	3650 7,800	2400 5,150	3300 7,300	2200 4,800	6440 21'0"
-3000 mm -10'0"	kg lb	*7300 *15,650	*7300 *15,650	*5750 *12,350	*5750 *12,350	*4150 *8,750	3550 7,650			*2950 *6,400	2750 6,150	5460 17'9"

## Reach Boom Lift Capacities – Counterweight: 3.83 mt (8,440 lb) – without Bucket – Blade Up

2500 mm (8'2") Blade

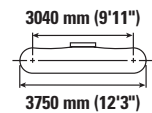
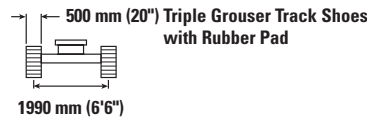
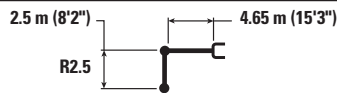

Reach Boom Lift Capacity	Unit	1500 mm (5'0")		3000 mm (10'0")		4500 mm (15'0")		6000 mm (20'0")		2500 mm (8'2") Blade		mm ft/in
		Hydraulic	Tipping	Hydraulic	Tipping	Hydraulic	Tipping	Hydraulic	Tipping	Hydraulic	Tipping	
7500 mm 25'0"	kg lb			*4350 *9,200	*4350 *9,200					*3250 *7,450	*3250 *7,450	3710 11'5"
6000 mm 20'0"	kg lb					*4050 *8,750	*4050 *8,750			*2600 *5,800	*2600 *5,800	5490 17'8"
4500 mm 15'0"	kg lb			*4150 *9,050	*4150 *9,050	*4500 *9,750	4350 9,350	*3700 *7,600	2750 5,950	*2450 *5,350	*2450 *5,350	6460 21'0"
3000 mm 10'0"	kg lb			*7400 *15,850	*7400 *15,850	*5150 *11,150	4150 8,900	4000 8,600	2700 5,800	*2450 *5,350	2150 4,700	6970 22'9"
1500 mm 5'0"	kg lb			*6800 *16,700	*6800 14,900	*5850 *12,600	3900 8,350	3900 8,400	2600 5,550	*2550 *5,600	2000 4,450	7130 23'4"
0 mm 0'0"	kg lb			*6250 *14,500	*6250 14,250	5850 12,500	3700 7,950	3800 8,150	2500 5,400	*2850 *6,250	2050 4,500	6960 22'9"
-1500 mm -5'0"	kg lb	*4750 *10,700	*4750 *10,700	*7900 *17,150	6600 14,150	*5550 *11,950	3650 7,800	3750 8,100	2450 5,300	*3400 *7,450	2250 5,000	6440 21'0"
-3000 mm -10'0"	kg lb	*7300 *15,650	*7300 *15,650	*5750 *12,350	*5750 *12,350	*4150 *8,750	3650 7,900			*2950 *6,400	2850 6,350	5460 17'9"



ISO 10567:2007



\* Indicates that the load is limited by hydraulic lifting capacity rather than tipping load. The above loads are in compliance with hydraulic excavator lift capacity standard ISO 10567:2007.

They do not exceed 87% of hydraulic lifting capacity or 75% of tipping load. Weight of all lifting accessories must be deducted from the above lifting capacities. Lifting capacities are based on the machine standing on a firm, uniform supporting surface. The use of a work tool attachment point to handle/lift objects, could affect the machine lift performance.

Lift capacity stays with ±5% for all available track shoes.

Always refer to the appropriate Operation and Maintenance Manual for specific product information.

# 315 GC Hydraulic Excavator Specifications

## Reach Boom Lift Capacities – Counterweight: 3.83 mt (8,440 lb) – without Bucket – Blade Up

2600 mm (8'6") Blade

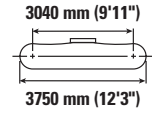
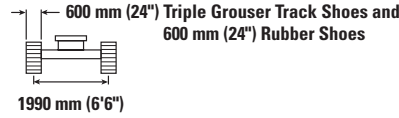
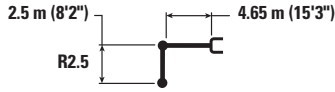

Reach Boom Lift Configuration	1500 mm (5'0")		3000 mm (10'0")		4500 mm (15'0")		6000 mm (20'0")		2600 mm (8'6") Blade		mm ft/in	
	Hydraulic	Tipping	Hydraulic	Tipping	Hydraulic	Tipping	Hydraulic	Tipping	Hydraulic	Tipping		
7500 mm 25'0"	kg lb		*4350 *9,200	*4350 *9,200					*3250 *7,450	*3250 *7,450	3710 11'5"	
6000 mm 20'0"	kg lb				*4050 *8,750	*4050 *8,750			*2600 *5,800	*2600 *5,800	5490 17'8"	
4500 mm 15'0"	kg lb		*4150 *9,050	*4150 *9,050	*4500 *9,750	4300 9,250	*3700 *7,600	2750 5,850	*2450 *5,350	2450 *5,350	6460 21'0"	
3000 mm 10'0"	kg lb		*7400 *15,850	*7400 *15,850	*5150 *11,150	4100 8,800	3950 8,500	2650 5,700	*2450 *5,350	2100 4,650	6970 22'9"	
1500 mm 5'0"	kg lb		*6800 *16,700	*6800 *14,750	*5850 *12,600	3850 8,250	3850 8,250	2550 5,500	*2550 *5,600	2000 4,400	7130 23'4"	
0 mm 0'0"	kg lb		*6250 *14,500	*6250 *14,050	5750 12,300	3650 7,850	3750 8,050	2500 5,300	*2850 *6,250	2050 4,450	6960 22'9"	
-1500 mm -5'0"	kg lb	*4750 *10,700	*4750 *10,700	*7900 *17,150	6500 14,000	*5550 *11,950	3600 7,700	3700 7,950	2450 5,250	3350 7,400	2250 4,900	6440 21'0"
-3000 mm -10'0"	kg lb	*7300 *15,650	*7300 *15,650	*5750 *12,350	*5750 *12,350	*4150 *8,750	3650 7,800		*2950 *6,400	2800 6,250	5460 17'9"	



ISO 10567:2007



\* Indicates that the load is limited by hydraulic lifting capacity rather than tipping load. The above loads are in compliance with hydraulic excavator lift capacity standard ISO 10567:2007. They do not exceed 87% of hydraulic lifting capacity or 75% of tipping load. Weight of all lifting accessories must be deducted from the above lifting capacities. Lifting capacities are based on the machine standing on a firm, uniform supporting surface. The use of a work tool attachment point to handle/lift objects, could affect the machine lift performance.

Lift capacity stays with ±5% for all available track shoes.

Always refer to the appropriate Operation and Maintenance Manual for specific product information.

# 315 GC Hydraulic Excavator Specifications

## Reach Boom Lift Capacities – Counterweight: 3.83 mt (8,440 lb) – without Bucket – Blade Up

2500 mm (8'2") Blade

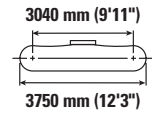
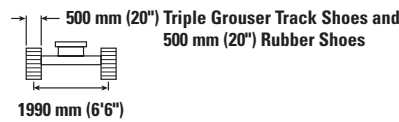
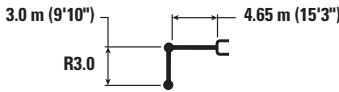

		1500 mm (5'0")		3000 mm (10'0")		4500 mm (15'0")		6000 mm (20'0")		7500 mm (25'0")		mm ft/in		
7500 mm 25'0"	kg lb					*2700	*2700					*2600 *5,850	*2600 *5,850	4540 14'3"
6000 mm 20'0"	kg lb					*3450 *7,550	*3450 *7,550	*2400	*2400			*2200 *4,850	*2200 *4,850	6070 19'8"
4500 mm 15'0"	kg lb					*3650 *7,950	*3650 *7,950	*3450 *7,400	2700 5,850			*2050 *4,500	*2050 *4,500	6960 22'8"
3000 mm 10'0"	kg lb			*5850 *12,100	*5850 *12,100	*4800 *10,350	4100 8,750	3900 8,400	2650 5,650			*2050 *4,500	1850 4,100	7440 24'4"
1500 mm 5'0"	kg lb			*8750 *18,800	6900 14,800	*5600 *12,050	3800 8,150	3800 8,100	2500 5,400	*2500	1800	*2150 *4,750	1750 3,850	7590 24'10"
0 mm 0'0"	kg lb			*7000 *16,150	6450 13,800	5650 12,100	3600 7,700	3650 7,850	2400 5,150			*2400 *5,250	1800 3,900	7430 24'4"
-1500 mm -5'0"	kg lb	*4300 *9,650	*4300 *9,650	*8500 *18,350	6300 13,550	5500 11,850	3450 7,450	3600 7,750	2350 5,050			*2850 *6,250	1950 4,250	6940 22'8"
-3000 mm -10'0"	kg lb	*7450 *16,700	*7450 *16,700	*6650 *14,350	6350 13,650	*4700 *10,000	3450 7,450	*3000	2350			*2950 *6,400	2350 5,200	6050 19'8"
-4500 mm -15'0"	kg lb			*3450 *7,050	*3450 *7,050							*2050 *4,250	*2050 *4,250	4490 14'4"

## Reach Boom Lift Capacities – Counterweight: 3.83 mt (8,440 lb) – without Bucket – Blade Up

2500 mm (8'2") Blade

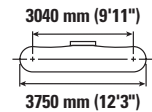
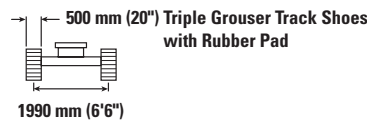
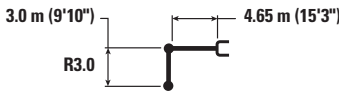

		1500 mm (5'0")		3000 mm (10'0")		4500 mm (15'0")		6000 mm (20'0")		7500 mm (25'0")		mm ft/in		
7500 mm 25'0"	kg lb					*2700	*2700					*2600 *5,850	*2600 *5,850	4540 14'3"
6000 mm 20'0"	kg lb					*3450 *7,550	*3450 *7,550	*2400	*2400			*2200 *4,850	*2200 *4,850	6070 19'8"
4500 mm 15'0"	kg lb					*3650 *7,950	*3650 *7,950	*3450 *7,400	2800 6,000			*2050 *4,500	*2050 *4,500	6960 22'8"
3000 mm 10'0"	kg lb			*5850 *12,100	*5850 *12,100	*4800 *10,350	4200 9,000	*3950 *8,550	2700 5,850			*2050 *4,500	1950 4,250	7440 24'4"
1500 mm 5'0"	kg lb			*8750 *18,800	7100 15,250	*5600 *12,050	3900 8,400	3900 8,400	2600 5,550	*2500	1850	*2150 *4,750	1850 4,000	7590 24'10"
0 mm 0'0"	kg lb			*7000 *16,150	6650 14,250	5850 12,550	3700 7,950	3800 8,150	2500 5,350			*2400 *5,250	1850 4,050	7430 24'4"
-1500 mm -5'0"	kg lb	*4300 *9,650	*4300 *9,650	*8500 *18,350	6500 14,000	5700 12,250	3600 7,700	3750 8,000	2450 5,200			*2850 *6,250	2000 4,400	6940 22'8"
-3000 mm -10'0"	kg lb	*7450 *16,700	*7450 *16,700	*6650 *14,350	6600 14,100	*4700 *10,000	3600 7,700	*3000	2450			*2950 *6,400	2450 5,400	6050 19'8"
-4500 mm -15'0"	kg lb			*3450 *7,050	*3450 *7,050							*2050 *4,250	*2050 *4,250	4490 14'4"



ISO 10567:2007



\* Indicates that the load is limited by hydraulic lifting capacity rather than tipping load. The above loads are in compliance with hydraulic excavator lift capacity standard ISO 10567:2007. They do not exceed 87% of hydraulic lifting capacity or 75% of tipping load. Weight of all lifting accessories must be deducted from the above lifting capacities. Lifting capacities are based on the machine standing on a firm, uniform supporting surface. The use of a work tool attachment point to handle/lift objects, could affect the machine lift performance.

Lift capacity stays with ±5% for all available track shoes.

Always refer to the appropriate Operation and Maintenance Manual for specific product information.

# 315 GC Hydraulic Excavator Specifications

## Reach Boom Lift Capacities – Counterweight: 3.83 mt (8,440 lb) – without Bucket – Blade Up

2600 mm (8'6") Blade

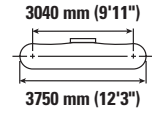
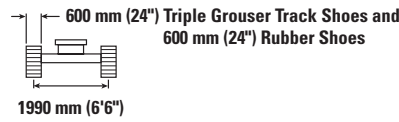
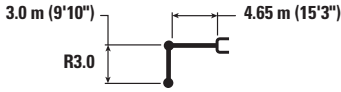

Reach (mm) Reach (ft/in)	kg lb	1500 mm (5'0")		3000 mm (10'0")		4500 mm (15'0")		6000 mm (20'0")		7500 mm (25'0")		2600 mm (8'6") Blade		
		kg lb	kg lb	kg lb	kg lb	kg lb	kg lb	kg lb	kg lb	kg lb	kg lb	kg lb	mm ft/in	
7500 mm 25'0"						*2700	*2700					*2600 *5,850	*2600 *5,850	4540 14'3"
6000 mm 20'0"						*3450 *7,550	*3450 *7,550	*2400	*2400			*2200 *4,850	*2200 *4,850	6070 19'8"
4500 mm 15'0"						*3650 *7,950	*3650 *7,950	*3450 *7,400	2800 5,950			*2050 *4,500	*2050 *4,500	6960 22'8"
3000 mm 10'0"				*5850 *12,100	*5850 *12,100	*4800 *10,350	4150 8,950	*3950 8,550	2700 5,750			*2050 *4,500	1900 4,200	7440 24'4"
1500 mm 5'0"				*8750 *18,800	7000 15,100	*5600 *12,050	3850 8,350	3850 8,250	2550 5,500	*2500	1850	*2150 *4,750	1800 3,950	7590 24'10"
0 mm 0'0"				*7000 *16,150	6550 14,100	5750 12,300	3650 7,850	3750 8,000	2450 5,300			*2400 *5,250	1850 4,000	7430 24'4"
-1500 mm -5'0"		*4300 *9,650	*4300 *9,650	*8500 *18,350	6450 13,800	5600 12,050	3550 7,600	3650 7,850	2400 5,150			*2850 *6,250	2000 4,350	6940 22'8"
-3000 mm -10'0"		*7450 *16,700	*7450 *16,700	*6650 *14,350	6500 13,950	*4700 *10,000	3550 7,650	*3000	2450			*2950 *6,400	2400 5,300	6050 19'8"
-4500 mm -15'0"				*3450 *7,050	*3450 *7,050							*2050 *4,250	*2050 *4,250	4490 14'4"



ISO 10567:2007



\* Indicates that the load is limited by hydraulic lifting capacity rather than tipping load. The above loads are in compliance with hydraulic excavator lift capacity standard ISO 10567:2007. They do not exceed 87% of hydraulic lifting capacity or 75% of tipping load. Weight of all lifting accessories must be deducted from the above lifting capacities. Lifting capacities are based on the machine standing on a firm, uniform supporting surface. The use of a work tool attachment point to handle/lift objects, could affect the machine lift performance.

Lift capacity stays with ±5% for all available track shoes.

Always refer to the appropriate Operation and Maintenance Manual for specific product information.



# 315 GC Hydraulic Excavator Specifications

## Bucket Specifications and Compatibility

	Linkage	Width		Capacity		Weight		Fill %	Reach Boom	
		mm	in	m <sup>3</sup>	yd <sup>3</sup>	kg	lb		R2.5 (8'2")	R3.0 (9'10")
<b>Pin-On (No Quick Coupler)</b>										
Utility Duty	312	450	18	0.20	0.26	256	565	100	●	●
	312	600	24	0.30	0.39	299	660	100	●	●
	312	900	36	0.50	0.65	388	856	100	●	●
General Duty	312	450	18	0.20	0.26	266	587	100	●	●
	312	600	24	0.31	0.40	310	684	100	●	●
	312	750	30	0.41	0.54	358	790	100	●	●
	312	750	30	0.41	0.54	410	903	100	●	●
	312	900	36	0.53	0.69	407	898	100	●	●
	312	900	36	0.53	0.69	451	994	100	●	●
	312	1050	42	0.65	0.84	457	1,006	100	●	⊙
Clean Up	312	1500	60	1.02	1.33	651	1,435	100	○	◇
	312	1800	72	1.29	1.68	748	1,649	100	◇	X
Ditch Cleaning Tilt	312	1500	60	0.74	0.98	704	1,553	100	⊖	○
	312	1800	72	0.90	1.18	784	1,728	100	○	◇
Maximum load with pin-on (payload + bucket)								kg	1930	1720
								lb	4,262	3,787
<b>With Cat Pin Grabber Coupler</b>										
Utility Duty	312	450	18	0.20	0.26	256	565	100	●	●
	312	600	24	0.30	0.39	299	660	100	●	●
	312	900	36	0.50	0.65	388	856	100	●	●
General Duty	312	450	18	0.20	0.26	266	587	100	●	●
	312	600	24	0.31	0.40	310	684	100	●	●
	312	750	30	0.41	0.54	358	790	100	●	●
	312	750	30	0.41	0.54	410	903	100	●	●
	312	900	36	0.53	0.69	407	898	100	●	●
	312	900	36	0.53	0.69	451	994	100	●	●
	312	1050	42	0.65	0.84	457	1,006	100	⊙	⊖
Clean Up	312	1500	60	1.02	1.33	651	1,435	100	◇	X
	312	1800	72	1.29	1.68	748	1,649	100	X	X
Ditch Cleaning Tilt	312	1500	60	0.74	0.98	704	1,553	100	○	◇
	312	1800	72	0.90	1.18	784	1,728	100	◇	X
Maximum load with coupler (payload + bucket)								kg	1734	1518
								lb	3,822	3,347

The above loads are in compliance with hydraulic excavator standard EN474-5:2006 + A3:2013, they do not exceed 87% of hydraulic lifting capacity or 75% of tipping capacity with front linkage fully extended at ground line with bucket curled. Capacity based on ISO 7451:2007.

### Maximum Material Density:

- 2100 kg/m<sup>3</sup> (3,500 lb/yd<sup>3</sup>)
- ⊙ 1800 kg/m<sup>3</sup> (3,000 lb/yd<sup>3</sup>)
- ⊖ 1500 kg/m<sup>3</sup> (2,500 lb/yd<sup>3</sup>)
- 1200 kg/m<sup>3</sup> (2,000 lb/yd<sup>3</sup>)
- ◇ 900 kg/m<sup>3</sup> (1,500 lb/yd<sup>3</sup>)

Caterpillar recommends using appropriate work tools to maximize the value customers receive from our products. Use of work tools, including buckets, which are outside of Caterpillar's recommendations or specifications for weight, dimensions, flows, pressures, etc. may result in less-than-optimal performance, including but not limited to reductions in production, stability, reliability, and component durability. Improper use of a work tool resulting in sweeping, prying, twisting and/or catching of heavy loads will reduce the life of the boom and stick.

# 315 GC Hydraulic Excavator Specifications

## Attachments Offering Guide

Not all Attachments are available in all regions. Consult your Cat dealer for configurations available in your region.

Match

† Allowed usage on machine less than 50%

### PIN-ON ATTACHMENTS

Boom Type		Reach Boom	
		R2.5 (8'2")	R3.0 (9'10")
Hydraulic Hammers	H110 GC	✓	✓
	H110 GC S	✓	✓
	H110 S	✓	✓
	H115 GC	✓	✓
	H115 GC S	✓	✓
	H115 S	✓	✓
Compactors (Vibratory Plate)	CVP75	✓	✓

### CAT PIN GRABBER COUPLER ATTACHMENTS

Boom Type		Reach Boom	
		R2.5 (8'2")	R3.0 (9'10")
Hydraulic Hammers	H110 GC	✓	✓
	H110 GC S	✓	✓
	H110 S	✓	✓
	H115 GC	✓	✓*
	H115 GC S	✓	✓
	H115 S	✓	✓
Compactors (Vibratory Plate)	CVP75	✓	✓

### BOOM-MOUNT ATTACHMENTS

Boom Type		Reach Boom
Mobile Scrap and Demolition Shears	S3025 Flat Top	✓

## Standard and Optional Equipment

Standard and optional equipment may vary. Consult your Cat dealer for details.

	Standard	Optional		Standard	Optional
<b>BOOMS, STICKS AND LINKAGES</b>			<b>CAT TECHNOLOGY</b>		
4.65 m (15'3") Reach boom	✓		VisionLink®	✓*	
2.5 m (8'2") Reach stick		✓	VisionLink Productivity		✓
3.0 m (9'10") Reach stick		✓	Remote Flash	✓	
Bucket linkage, with lifting eye	✓		<b>ELECTRICAL SYSTEM</b>		
<b>CAB</b>			Maintenance free battery	✓	
ROPS	✓		Centralized electrical disconnect switch	✓	
High-resolution 203 mm (8") LCD touch screen monitor	✓		LED chassis light, left-hand boom light, cab light – 1,800 lumens	✓	
Auto bi-level air conditioner	✓		LED right-hand boom light – 1,800 lumens		✓
Jog dial and shortcut keys for monitor control	✓		Programmable time-delay LED working lights	✓	
Keyless push-to-start engine control	✓		<b>ENGINE</b>		
Height-adjustable console	✓		Cat® C3.6 single turbo diesel engine	✓	
Tilt-up left-side console	✓		Two selectable modes: Power, Smart	✓	
Mechanical-suspension seat	✓		Automatic engine speed control	✓	
51 mm (2") seat belt	✓		Engine Idle Shutdown	✓	
Bluetooth® integrated radio (with USB, auxiliary port or microphone)	✓		52° C (125° F) high-ambient cooling capacity without derate	✓	
12V DC outlets	✓		–25° C (–13° F) cold start capability	✓	
Document storage	✓		Variable speed fan	✓	
Cup and bottle holders	✓		Single fuel filtration system with water separator and indicator	✓	
Openable two-piece front window	✓		Sealed double element air filter with pre-cleaner	✓	
Rear window emergency exit	✓				
Upper radial wiper with washer	✓				
Openable steel hatch	✓				
LED dome light	✓				
Roller front sunscreen		✓			
Washable floor mat	✓				
Beacon ready	✓				

(continued on next page)

\*Connect subscription only. Additional subscriptions are available. Contact your Cat dealer for availability.

# 315 GC Standard and Optional Equipment

## Standard and Optional Equipment *(continued)*

Standard and optional equipment may vary. Consult your Cat dealer for details.

	Standard	Optional		Standard	Optional
<b>HYDRAULIC SYSTEM</b>			<b>SERVICE AND MAINTENANCE</b>		
Electronic main control valve	✓		Integrated vehicle health management system	✓	
Single type electronic pump	✓		Lockable disconnect switch	✓	
Boom and stick regeneration circuits	✓		Grouped engine oil and fuel filters	✓	
Automatic two-speed travel	✓		Ground level engine oil dipstick	✓	
Boom and stick drift reduction valve	✓		Scheduled Oil Sampling (S·O·S <sup>SM</sup> ) ports	✓	
Swing drive, without fine swing control function	✓		<b>UNDERCARRIAGE AND STRUCTURES</b>		
Boom and stick lowering check valves <sup>2</sup>	✓		500 mm (20") triple grouser track shoes		✓
Medium-pressure line		✓	500 mm (20") triple grouser track shoes with rubber pad		✓
High-pressure line		✓	500 mm (20") rubber shoes		✓
Quick coupler line		✓	600 mm (24") triple grouser track shoes		✓
<b>SAFETY AND SECURITY</b>			600 mm (24") rubber shoes		✓
Rear and right-side-view cameras	✓		700 mm (28") triple grouser track shoes <sup>1</sup>		✓
Ground level engine shutoff switch	✓		2500 mm (8'2") blade <sup>2</sup>		✓
Service platform with anti-skid plate and countersunk bolts	✓		2600 mm (8'6") blade <sup>2</sup>		✓
Signaling/warning horn	✓		Grease lubricated track link	✓	
Swing alarm		✓	Center track guiding guards	✓	
Inspection lighting		✓	Travel motor guards	✓	
			Bottom guards	✓	
			3830 kg (8,440 lb) counterweight	✓	
			Tie-down points on base frame	✓	

<sup>1</sup>Singapore only

<sup>2</sup>Australia/New Zealand only

## Dealer Installed Kits and Attachments

Attachments may vary. Consult your Cat dealer for details.

### CAB

- Radial lower wiper
- Left-hand and right-hand electrical pedal (two-way) for tool control
- Dual exit rear window kit
- Rain protector plus cab light cover
- Polycarbonate roof hatch
- Front windshield laminated glass (P5A glass, EU demolition regulation)
- Key fob (for use with Bluetooth receiver)

### SAFETY AND SECURITY

- Bluetooth receiver
- 76 mm (3") retractable seat belt

### GUARDS

- Operator Protective Guards (OPG) (not compatible with cab light cover, rain protector)
- Mesh guard full front (not compatible with cab light cover, rain protector)
- Mesh guard lower half front
- Full protecting vandalism guard

### OTHER

- Grease gun holder

# 315 GC Environmental Declaration

The following information applies to the machine at the time of final manufacture as configured for sale in the regions covered in this document. The content of this declaration is valid as of the date issued; however, content related to machine features and specifications are subject to change without notice. For additional information, please see the machine's Operation and Maintenance Manual.

For more information on sustainability in action and our progress, please visit <https://www.caterpillar.com/en/company/sustainability>.

## Engine

- Emits equivalent to U.S. EPA Tier 3.
  - Cat engines are compatible with diesel fuel blended with the following lower-carbon intensity fuels\*\* up to:
    - ✓ 100% biodiesel FAME (fatty acid methyl ester)\*
    - ✓ 100% renewable diesel, HVO (hydrotreated vegetable oil) and GTL (gas-to-liquid) fuels
- Refer to guidelines for successful application. Please consult your Cat dealer or “Caterpillar Machine Fluids Recommendations” (SEBU6250) for details.
- \*For use of blends higher than 20% biodiesel, consult your Cat dealer.*
- \*\*Lower-carbon intensity fuels do not significantly reduce GHGs at the tailpipe.*

## Air Conditioning System

- The air conditioning system on this machine contains the fluorinated greenhouse gas refrigerant R134a (Global Warming Potential = 1430). The system contains 0.8 kg (1.8 lb) of refrigerant which has a CO<sub>2</sub> equivalent of 1.144 metric tonnes (1.261 tons).

## Paint

- Based on best available knowledge, the maximum allowable concentration, measured in parts per million (PPM), of the following heavy metals in paint are:
  - Barium < 0.01%
  - Cadmium < 0.01%
  - Chromium < 0.01%
  - Lead < 0.01%

## Sound Performance

ISO 6395:2008 (external)	101 dB(A)
ISO 6396:2008 (inside cab)	71 dB(A)

- Hearing protection may be needed when operating with an open operator station and cab (when not properly maintained or doors/windows open) for extended periods or in a noisy environment.

## Oils and Fluids

- Caterpillar factory fills with ethylene glycol coolants. Cat Diesel Engine Antifreeze/Coolant (DEAC) and Cat Extended Life Coolant (ELC) can be recycled. Consult your Cat dealer for more information.
- Cat Bio HYDO™ Advanced is an EU Ecolabel approved biodegradable hydraulic oil.
- Additional fluids are likely to be present, please consult the Operations and Maintenance Manual or the Application and Installation guide for complete fluid recommendations and maintenance intervals.

## Features and Technology

- The following features and technology may contribute to fuel savings and/or carbon reduction. Features may vary. Consult your Cat dealer for details.
  - Advanced hydraulic systems balance power and efficiency
  - Smart mode matches machine power to digging requirements automatically
  - Eco mode minimizes fuel consumption for light applications
  - One-touch low idle with automatic engine speed control
  - Cut maintenance costs up to 25% with extended and synchronized intervals
  - Remote Flash and Remote Troubleshoot

## Recycling

- The materials included in machines are categorized as below with approximate weight percentage. Because of variations of product configurations, the following values in the table may vary.

Material Type	Weight Percentage
Steel	83.27%
Iron	5.01%
Nonferrous Metal	1.86%
Mixed Metal	0.37%
Mixed-Metal and Nonmetal	2.40%
Plastic	0.08%
Rubber	1.67%
Mixed Nonmetallic	1.45%
Fluid	2.40%
Other	1.49%
Uncategorized	0.00%
Total	100%

- A machine with higher recyclability rate will ensure more efficient usage of valuable natural resources and enhance End-of-Life value of the product. According to ISO 16714:2008 (Earthmoving machinery – Recyclability and recoverability – Terminology and calculation method), recyclability rate is defined as percentage by mass (mass fraction in percent) of the new machine potentially able to be recycled, reused or both.

All parts in the bill of material are first evaluated by component type based on a list of components defined by the ISO 16714:2008 and Japan CEMA (Construction Equipment Manufacturers Association) standards. Remaining parts are further evaluated for recyclability based on material type.

Because of variations of product configurations, the following value in the table may vary.

Recyclability – 95%

For more complete information on Cat products, dealer services, and industry solutions, visit us on the web at [www.cat.com](http://www.cat.com)

© 2023 Caterpillar  
All rights reserved

Materials and specifications are subject to change without notice. Featured machines in photos may include additional equipment. See your Cat dealer for available options.

CAT, CATERPILLAR, LET'S DO THE WORK, their respective logos, "Caterpillar Corporate Yellow," the "Power Edge" and Cat "Modern Hex" trade dress as well as corporate and product identity used herein, are trademarks of Caterpillar and may not be used without permission. VisionLink is a trademark of Caterpillar Inc., registered in the United States and in other countries.

AEXQ3640-01 (11-2023)  
Replaces AEXQ3640  
Build Number: 07E  
(Auz-NZ, Singapore)

