



K/K2 SERIES MOTOR GRADERS COVERING 12K, 120K, 120K2, 140K, 140K2, 160K PARTS REFERENCE GUIDE

LET'S DO THE WORK.™



PROTECT YOUR INVESTMENT WITH GENUINE CAT® PARTS

Thank you for selecting the Cat® Motor Grader.

This guide is designed to provide you with a quick reference for the parts and part numbers you need to keep your Cat® motor grader running at peak efficiency. Always read and understand the machine's Operation and Maintenance Manual prior to performing any type of maintenance.



MAINTENANCE

Proactive preventative maintenance extends the life of your machine and protects your investment. Only Caterpillar knows Cat equipment's filtration and lubrication requirements and offers parts kits to match your machine's maintenance cycles.



SCHEDULED MAINTENANCE PARTS	
	PLANNED MAINTENANCE

REPLACEMENT PARTS

Proper maintenance minimizes the need for repair and replacement. In the event that replacement parts are required for this product, Caterpillar recommends using original Caterpillar® replacement parts. Other parts may not meet certain original equipment specifications.

REPAIR PARTS	
	CAB ACCESSORIES
	ENGINE & ENGINE COMPONENTS
	LIGHTS, MIRRORS & FUSES
	BATTERIES
WEAR PARTS	
	GROUND ENGAGING TOOLS
	LINKAGE PINS & BEARINGS

GREASES

Previous Cat Product Name	STANDARD MAINTENANCE GREASES			GREASES FOR UNIQUE APPLICATIONS AND ENVIRONMENTS		
	Cat Ultra5 Moly #1	Cat Ultra5 Moly #2	Cat Advanced 3 Moly	Cat Arctic Platinum	Cat Desert Gold	Cat Multipurpose
Current Cat Product Name	Cat Extreme Application Grease 1	Cat Extreme Application Grease 2	Cat Prime Application Grease	Cat Extreme Application Grease - Arctic	Cat Extreme Application Grease - Desert	Cat Utility Grease
Grade (NLGI)	1	2	2	0	2	2
Melting point (deg C)	>260	>260	260	230	280	260
Ambient Temperature (deg C)	-35 to +40	-30 to +50	-20 to +40	-35 to +40	-30 to +50	-30 to +40
Base Oil Type	Mineral	Mineral	Mineral	Semi-Synthetic	Mineral	Mineral
Color	Dark Gray	Dark Gray	Dark Gray	Dark Grey	Dark Grey	Blue
Cartridge (390 g / 14 oz)	452-5996	452-6001	452-6006	508-2184	452-6016	452-6011
Plastic Pail (5 kg / 11 lb)	-	-	-	-	-	-
Plastic Pail (16 kg / 35 lb)	452-5999	452-6004	452-6009	508-2187	452-6019	452-6014
Keg (55 kg / 120 lb)	452-5998	452-6003	452-6008	508-2186	452-6018	452-6013
Drum (180 kg / 400 lb)	452-5997	452-6002	452-6007	508-2185	452-6017	452-6012
						

PLANNED MAINTENANCE

MOTOR GRADER		INITIAL 100 HOURS	
		Transmission / Lower Power Train	
Sales Model	Serial Number	Filler Tube Breather	Filter Element
120K	JAP	183-3873	337-5270
	SZN		
120K2	SZZ		
	SZS		
12K	JJA		
	SZP		
140K	JPA		
	SZL		
140K2	SZW		
160K	JBP		
	SZM		

MOTOR GRADER		EVERY 100 HOURS	
		Cabin Air Clean/Replace	
Sales Model	Serial Number Prefix	Fresh Air Element	Recirculating Element
120K	JAP	7T-7358	231-4487 (Quantity 2)
	SZN		
120K2	SZZ		
	SZS		
12K	JJA		
	SZP		
140K	JPA		
	SZL		
140K2	SZW		
160K	JBP		
	SZM		

MOTOR GRADER		EVERY 500 HOURS						
		Engine Oil/Filter Change		Fuel Filter Change			Transmission / Lower Power Train	Hydraulic Oil/Filter Change
Sales Model	Serial Number Prefix	Filter Element	Oil Quantity - Liter (Gallon) DEO-ULS TM	Primary Element	Secondary Element	Tertiary Element	Tandem Breather	Filter Element
120K	JAP	1R-1807	18 (4.8 US Gal)	326-1644 (New Canister Style Filter) 436-7077	1R-0762 (New Canister Style Filter) 500-0480	1R-0762 (New Canister Style Filter) 500-0480	4H-6112 (Quantity 2)	—
	SZN							
120K2	SZZ							
	SZS							
12K	JJA							
	SZP							
140K	JPA							
	SZL							
140K2	SZW							
160K	JBP							
	SZM							

PLANNED MAINTENANCE

MOTOR GRADER		EVERY 1,000 HOURS			
		Transmission / Lower Power Train		Transmission And Differential Oil	Hydraulic Oil/Filter Change
Sales Model	Serial Number Prefix	Filler Tube Breather	Filter Element	Oil Quantity - Liter (Gallon) TDTO	Filter Element
120K	JAP	183-3873	337-5270	47 (12.4 US Gal)	1R-0774
	SZN				
120K2	SZZ				
	SZS				
12K	JJA				
	SZP				
140K	JPA				
	SZL				
140K2	SZW				
160K	JBP				
	SZM				

MOTOR GRADER		EVERY 2,000 HOURS				
		Battery X2 12-VOLT 750-CCA	Circle Drive Oil	Cooling System Pressure Cap	Tandem Drive Oil (for each side)	Front Wheel Bearing Oil
Sales Model	Serial Number Prefix	Check/Change	Oil Quantity - Liter (Gallon) Cat GO	Change	Oil Quantity - Liter (Gallon) TDTO	Oil Quantity - Liter (Gallon) TDTO
120K	JAP	3T-5760 Standard 153-5710 Extreme Duty	7 (1.8 US Gal)	251-3227	64 (16.9 US Gal)	0.5 (0.13 US Gal)
	SZN					
120K2	SZZ					
	SZS					
12K	JJA					
	SZP					
140K	JPA					
	SZL					
140K2	SZW					
160K	JBP					
	SZM					

MOTOR GRADER		EVERY 3,000 HOURS
		Seat Belt
Sales Model	Serial Number Prefix	3 year Change
120K	JAP	513-0286
	SZN	
120K2	SZZ	
	SZS	
12K	JJA	
	SZP	
140K	JPA	
	SZL	
140K2	SZW	
160K	JBP	
	SZM	

PLANNED MAINTENANCE

MOTOR GRADER		EVERY 6,000 HOURS	
		Hydraulic System Oil	Temp Regulator 97-DEG
Sales Model	Serial Number Prefix	Oil Quantity - Liter (Gallon) HYDO Advanced 10	Change
120K	JAP	55 (14.5 US Gal)	—
	SZN		—
120K2	SZZ		—
	SZS		—
12K	JJA		115-4223
	SZP		115-4223
140K	JPA		115-4223
	SZL		115-4223
140K2	SZW		—
160K	JBP		115-4223
	SZM	115-4223	

MOTOR GRADER		EVERY 12,000 HOURS	
		Cooling System	
Sales Model	Serial Number Prefix	Cat Extended Life Coolant (ELC)	
120K	JAP	40 (10.6 US Gal)	
	SZN		
120K2	SZZ		
	SZS		
12K	JJA		
	SZP		
140K	JPA		
	SZL		
140K2	SZW		
160K	JBP		
	SZM		



MOTOR GRADER		WHEN REQUIRED								
		Engine Crankcase	Air Filter Engine Clean/Replace		Engine Air Filter Service Indicator	Belts Adjust Replace		Ether Starting Aid	Window Wiper Blade Inspect Replace	
Sales Model	Serial Number Prefix	Breather Element	Primary Element	Secondary Element	Inspect Replace	Serpentine	Fan	Inspect Replace	Front lower x 2	Front Upper
120K	JAP	164-0210	245-6375	245-6376	145-4212	198-3611	9L-1630	275-3634	123-4355	6V-5853
	SZN									
120K2	SZZ									
	SZS									
12K	JJA									
	SZP									
140K	JPA									
	SZL									
140K2	SZW									
160K	JBP									
	SZM									



GROUND ENGAGING TOOLS 12' BLADES

12' Blades	120K/K2	JAP,SZN, SZZ, SZS
	12K	JJA,SZP
3/4" Bolt Holes	140K/K2	JPA, SZL, SZW

Moldboard Cutting Edges																
Profile	Type	Width Tooth X Gap (mm)	Length	Quantity	Hardware	Thickness				End Bits	Bolts Required	Overlay	Hardware			
						13mm (0.5 in)	16mm (0.6 in)	19mm (0.7 in)	25mm (1 in)							
Curved	Standard	152 mm (6 in)	1.8 m (6 ft)	2	13	9J-3660	9J-3657	-	-	8E-5529	5	232-21421	4			
		203 mm (8 in)										9J-7701	7D-1576	4T-2231	6Y-2805	4
	General Duty	152 mm (6 in)										7T-1637	-	-	-	-
		203 mm (8 in)										7T-1639	7T-1638	-	-	-
	Serrated	203 mm (8 in) - 36X25										-	399-2791	-	-	-
		203 mm (8 in) - 62X40										-	-	-	138-0857	-
	203 mm (8 in) - 62X40	0.9 m (3 ft)	4	5	-	-	138-0859	-	-	-	-					
Flat	Standard	203 mm (8 in)	1.8 m (6 ft)	2	13	-	-	-	-	-	-	-	-			
		254 mm (10 in)												4T-2971	4T-3033	7T-3493
	Serrated	203 mm (8 in) - 12X62	1.2 m (4 ft)	3	9									-	-	-

Carbide Edges															
Curved	Tungsten Carbide	121 mm (4.75 in)	0.6 m (2 ft)	6	5	-	-	-	-	8E-5529	5	135-9369	4		
			0.9 m (3 ft)	4	7							208-8863	217-4698	-	-
		171 mm (6.75 in)	0.6 m (2 ft)	6	5							195-7266	195-7267	-	-
			0.9 m (3 ft)	4	7							208-8866	-	208-8865	135-9370
		1.2 m (4 ft)	3	9	-							-	217-4697	-	-
		Tungsten Carbide Serrated	171 mm (6.75 in) - 62X40	0.6 m (2 ft)	6							5	-	-	-
		0.9 m (3 ft)	4	7	-	-	-	-	-	-	-	-			
Flat	Carbide Insert	127 mm (5 in)	1.2 m (4 ft)	3	6	-	-	-	-	-	-	-	-		
		152 mm (6 in)	0.9 m (3 ft)	4	5	283-1063	330-9491	-	-	-	-	-	-		
			1.2 m (4 ft)	3	6	286-3148	-	-	-	-	-	-	-		





Specialty									
Type	Width	Length	Qty	Hardware	Adapter Board	Bits per Board	Shank Size	Bits	Notes
Rotating Bit	150 mm (5.9 in)	0.9 m (3 ft)	4	7	307-2613	21	22 mm (7/8 in)	348-9051	
		1.2 m (4 ft)	3	9	307-2615	28			
	183 mm (7.2 in)	0.9 m (3 ft)	4	7	323-1251	21	25 mm (1 in)	322-7295	
		1.2 m (4 ft)	3	9	321-4272	28			

Type	Bit Spacing	Width	Length	Qty	Hardware	Adapter Board	Bits per Board	Bits				Notes
								15.5mm	23mm	30mm	63.5mm	
Mining Bit	Narrow Gap	197 mm (7.75 in)	0.6 m (2 ft)	6	4	428-6758	9	-	-	308-5193	355-1496	
			0.9 m (3 ft)	4	7	135-9592	13					
	Wide Gap		0.6 m (2 ft)	6	4	428-6757	7					
			0.9 m (3 ft)	4	7	135-9591	10					
Grader Bit	Narrow Gap	197 mm (7.75 in)	0.6 m (2 ft)	6	4	428-6747	10	105-5183	105-5180	6Y-4339	6Y-4340	
			0.9 m (3 ft)	4	7	159-0318	15					
	Wide Gap		0.6 m (2 ft)	6	4	428-6746	8					
			0.9 m (3 ft)	4	7	159-0313	12					

GROUND ENGAGING TOOLS 12' BLADES

Auxiliary Blade Cutting Edges											
Profile	Type	Width	Length	Qty	Hardware	Thickness				Notes	
						13mm	16mm	19mm	25mm		
Front Mount Blades	9 ft Blade	203 mm (8 in)	660 mm (26 in)	2	4			4T-3010			
			1422 mm (56 in)	1	9			169-4089			
0.6 m (2 ft) Extension	Curved	152 mm (6 in)	610 mm (24 in)	1	4		232-2146	-		Left: 452-3133 Right: 243-6685	
		203 mm (8 in)	610 mm (24 in)	1	4		3G-2166	3G-2165			
Rippers / Scarifiers											
Adapter Size	Shanks			Tips			Pin	Retainer	Misc		
	Type	Part Number		Type	Std	A.R.M.					
Rear Mount R300	Straight	9J-6586	Contact your dealer for custom cutting edge combinations.	Penetration	6Y-0309	168-1309	136-8308	114-0359	Repair Nose 8E-7300		
	Curved	9J-8913		Sharp	9W-7309	-					
Scarifier V-Block4	Standard	195-7218		General Purpose	195-7234	-	5K-1459	5K-1458	Tip Removal Tool 6B-3260		
	Long	7D-4501		High Temp	6Y-5230	143-3074					
Scarifier Straight Block5	Standard	195-7219		General Purpose	195-7234	-					
	Long	-		High Temp	6Y-5230	143-3074					
Hardware and Wear Protection											
Type	Application	Hardware		Quantity	Bolts	Nuts	Washers	Notes			
Hardware	Standard Edges	Bolts	3/4-10 x 2-1/2	26	5J-4773	2J-3506	5P-8248	Inspect moldboard for excess wear. Ensure moldboard and new edges are free from paint and debris. Torque 3/4" Nuts to 350 +/- 45 ft. lb.			
	Specialty	Bolts	3/4-10 x 2-3/4	23	5J-4771						
	End Bits	Bolts	3/4-10 x 2-1/2	10	5J-4773						
	Overlays	Bolts	3/4-10 x 3-3/4	8	5F-8933						
	Front Blade	Bolts	3/4-10 x 2-1/4	17	4F-7827						
	Extension	Bolts	3/4-10 x 2-1/4	4	5J-4773						
Wear Protection	Moldboard Plate	343 mm (13.5 in) Radius	4D-5820	2	-	-	-				
		413 mm (16.25 in) Radius	8W-5265	2	-	-	-				

1 for 6" edges used on 120M, 140M, 12M, 160M 4 Front Notched 5 Rear Notched



Grader Bit 2												
	Part Number	Name	Length	Hardware	Bits per Board	Adapters per Moldboard	Bit Part Number	Bit Part Name	Width (mm)	Notes		
GraderBit2	552-8520	Left Hand Adapter Board	2'	5	10	2	552-8524	Penetration Bit	15	   		
							552-8525	Sharp Bit	20			
	552-8521	2' Center Adapter Board	2'	4	10	2	552-8526	Standard Bit	30			
							552-8527	Wide Bit	60			
	552-8523	Right Hand Adapter Board	2'	4	10	2	552-8528	Standard Mining Bit	30		552-8524	
							552-8529	Wide Mining Bit	60		552-8525	
							560-8840	SnowBit	60		552-8526	
							563-1186	BoreSaver	-		552-8527	
									552-8528	552-8529	560-8840	563-1186
Type	Part Number		Angle		Length		Quantity					
Angling Plate	552-9410		0°		1'		12					
	552-9411		5°									
	552-9412		10°									
	552-9413		15°									
	552-9414		20°									
	552-9415		25°									
	552-9416		30°									

GROUND ENGAGING TOOLS 14' BLADES

14' Blades	12K	JJA,SZP
	140K/K2	JPA, SZL, SZW
	160K	JBP, SZM

Moldboard Cutting Edges																
Profile	Type	Width Tooth X Gap (mm)	Length	Qty	Hardware	Thickness				End Bits	Hardware	Overlay	Hardware			
						16mm	19mm	25mm	35mm							
Curved	Standard	152 mm (6 in)	2.1 m (7 ft)	2	15	9J-3658	-	-	-	8E-5529	5	6Y-2805	4			
		203 mm (8 in)				7D-1158	7D-1577	4T-2233								
	General Duty	152 mm (6 in)				-	4Z-8785	-								
		203 mm (8 in)				7T-1626	-	-								
	Serrated	203 mm (8 in) - 36X25				-	7T-1624	7T-1625						283-1068	311-7674	350-7201
		203 mm (8 in) - 51X26				-	-	350-7200						217-4833	-	-
Flat	Standard	203 mm (8 in)	2.1 m (7 ft)	2	15	4T-2970	4T-3032	7T-3494	-	-	-	-	-			
		254 mm (10 in)				-	4T-6508	4T-8316								
		279 mm (11 in)				-	140-6790	-								
	Serrated	203 mm (8 in) - 51X26				350-0180	-	-								
		10" - 56X33				-	4Z-8055	4Z-8346								









Carbide Edges													
Curved	Tungsten Carbide	121 mm (4.75 in)	0.6 m (2 ft)	4	5	-	208-8863	-	-	8E-5529	5	135-9369	4
		0.9 m (3 ft)	2	7	217-4698		135-9370					4	
		171 mm (6.75 in)	0.9 m (3 ft)	2	7		217-4699					-	-
		1.2 m (4 ft)	2	9	208-8866		-					-	
	Tungsten Carbide Serrated	171 mm (6.75 in) - 62X40	0.6 m (2 ft)	4	5		-					208-8865	-
171 mm (6.75 in) - 62X40	0.9 m (3 ft)	2	7	-	217-4697	-	-						
Flat	Carbide Insert	152 mm (6 in)	0.9 m (3 ft) 1.2 m (4 ft)	2	5 6	330-9491 286-3148	-	-	-	-	-	-	-

Specialty												
Type	Width	Length	Qty	Hardware	Adapter Board	Bits per Board	Shank Size	Bits	Notes			
Rotating Bit	150 mm (5.9 in)	0.9 m (3 ft) 1.2 m (4 ft)	2	7 9	307-2613 307-2615	21 28	22 mm (7/8 in)	348-9051				
	183 mm (7.2 in)		2	7 9	323-1251 321-4272	21 28	25 mm (1 in)	322-7295				
Type	Bit Spacing	Width	Length	Qty	Hardware	Adapter Board	Bits per Board	Bits				Notes
Mining Bit	Narrow Gap	197 mm (7.75 in)	0.6 m (2 ft) 0.9 m (3 ft)	4	4	428-6758	9	-	-	308-5193	355-1496	
	2			7	135-9592	13						
Wide Gap	4			4	428-6757	7						
	2			7	135-9591	10						
Grader Bit	Narrow Gap	4	4	428-6747	10	105-5183	105-5180	6Y-4339	6Y-4340			
	2	7	159-0318	15								
Wide Gap	4	4	428-6746	8								
	2	7	159-0313	12								

GROUND ENGAGING TOOLS 14' BLADES

Auxiliary Blade Cutting Edges											
Profile	Type	Width	Length	Qty	Hardware	Thickness				Notes	
						13mm	16mm	19mm	25mm		
Front Mount Blades	9 ft Blade	203 mm (8 in)	660 mm (26 in) 1422 mm (56 in)	2 1	4 9			4T-3010 169-4089		uses 3/4" bolts	
	8 ft Blade	203 mm (8 in)	462 mm (18 in) 1557 mm (61.3 in)	2 1	3 10			-			4T-8353 4T-2315
	9'7" Foldable	203 mm (8 in)	462 mm (18 in) 2002 mm (78.8 in)	2 1	3 13						4T-8353 4T-8378
0.6 m (2 ft) Extension	Curved	152 mm (6 in)	610 mm (24 in)	1	4		3G-2166	3G-2165		Left: 452-3133 Right: 243-6685	
Rippers / Scarifiers											
Adapter Size	Shanks			Tips			Pin	Retainer	Misc		
	Type	Part Number		Type	Std	A.R.M.					
Rear Mount R300	Straight	9J-6586	Don't see what you need? Ask about our MAO* program.	Penetration	6Y-0309	168-1309	136-8308	114-0359	Repair Nose 8E-7300		
	Curved	9J-8913		Sharp	9W-7309	-					
Scarifier V-Block4	Standard	195-7218		General Purpose	195-7234	-	5K-1459	5K-1458	Tip Removal Tool 6B-3260		
	Long	7D-4501		High Temp	6Y-5230	143-3074					
Scarifier Straight Block5	Standard	195-7219		General Purpose	195-7234	-					
	Long	-		High Temp	6Y-5230	143-3074					
Hardware and Wear Protection											
Type	Application	Hardware		Quantity	Bolts	Nuts	Washers	Notes			
Hardware	Standard Edges	Bolts		3/4-10 x 2-1/2	30	5J-4773	2J-3506	5P-8248	Inspect moldboard for excess wear. Ensure moldboard and new edges are free from paint and debris. Torque 3/4" Nuts to 350 +/- 45 ft. lb.		
	Specialty	Bolts		3/4-10 x 2-3/4	30	5J-4771					
	End Bits	Bolts	3/4-10 x 2-1/2	10	5J-4773						
	Overlays	Bolts	3/4-10 x 3-3/4	8	5F-8933						
	Front Blade	Bolts	3/4-10 x 2-1/4	see above	4F-7827						
	Extension	Bolts	3/4-10 x 2-1/4	4	5J-4773						
Wear Protection	Moldboard Plate	343 mm (13.5 in) Radius	4D-5821	2	-	-	-	-			
		413 mm (16.25 in) Radius	8W-5266	2	-	-	-	-			

4 Front Notched 5 Rear Notched *MAO -Made as Ordered

GraderBit2													
	Part Number	Name	Length	Hardware	Bits per Board	Adapters per Moldboard	Bit Part Number	Bit Part Name	Width (mm)	Notes			
GraderBit2	552-8520	Left Hand Adapter Board	2	5	10	2	552-8524	Penetration Bit	15				
							552-8525	Sharp Bit	20				
							552-8526	Standard Bit	30				
							552-8527	Wide Bit	60				
	552-8522	3' Center Adapter Board	2	6	15	2	552-8528	Standard Mining Bit	30	552-8524	552-8525	552-8526	552-8527
							552-8529	Wide Mining Bit	60				
	552-8523	Right Hand Adapter Board	2	4	10	2	552-8540	SnowBit	-				
563-1186							BoreSaver	-					
Type		Part Number		Angle		Length		Quantity					
Angling Plate		552-9410		0°		1'		14					
		552-9411		5°									
		552-9412		10°									
		552-9413		15°									
		552-9414		20°									
		552-9415		25°									
		552-9416		30°									

MIRRORS, LIGHTS, AND FUSES

Sales Model	Serial Number Prefix	Mirrors - Description	Part Number	Quantity
12K, 120K, 120K2, 140K, 140K2, 160K	JJA, SZP, JAP, SZN, SZS, JPA, SZL, SZW, JBP, SZM	Left or Right Exterior Rear View Heated Mirror	259-4759	1
	JJA, SZP, JAP, SZN, SZZ, SZS, JPA, SZL, SZW, JBP, SZM	Left or Right Exterior Rear View Mirror	259-4758	1
	JJA, SZP, JAP, SZN, SZZ, SZS, JPA, SZL, SZW, JBP, SZM	Interior Dual Mirror	232-6114	1
	JJA, SZP, JAP, SZN, SZZ, SZS, JPA, SZL, SZW, JBP, SZM	Interior Single Mirror	462-3542	1
	JJA, SZP, JAP, SZN, SZS, JPA, SZL, SZW, JBP, SZM	Left or Right Exterior Rear View Mirror	197-2055	1
	JJA, SZP, JAP, SZN, SZS, JPA, SZL, SZW, JBP, SZM	Left or Right Exterior Curved Mirror	340-7076	1
	JJA, SZP, JAP, SZN, SZS, JPA, SZL, SZW, JBP, SZM	Left or Right Exterior Round Mirror	339-6543	1



MIRRORS, LIGHTS, AND FUSES

Sales Model	Serial Number Prefix	Lights - Description	Part Number	Quantity
12K, 120K, 120K2, 140K, 140K2, 160K	JJA, SZP, JAP, SZN, SZS, JPA, SZL, SZW, JBP, SZM	Dome Light Assembly (LED Strobe)	338-1132	1
120K, 120K2, 140K, 140K2	JAP, SZN, JPA, SZL, SZW	Dome Light Assembly (Standard)	3E-6389	1

Sales Model	Serial Number Prefix	Lights Name	Description	Part Number	Quantity
12K, 120K, 120K2, 140K, 140K2, 160K	JJA, SZP, JAP, SZN, SZZ, SZS, JPA, SZL, SZW, JBP, SZM	Lamp Flood Low Beam	Low Bar Low Beam Ripper Front Heel, Toe Front flood lights	612-5378	2
	JJA, SZP, JAP, SZN, SZS, JPA, SZL, SZW, JBP, SZM	Lamp Flood High Beam	Low Bar High Beam Rooding high beam Flood Light Assembly	234-4324	2
	JJA, SZP, JAP, SZN, SZZ, SZS, JPA, SZL, SZW, JBP, SZM	Flood and Signal	Low Bar Flood and Signal Lights Right Hand	486-4542	1
			Low Bar Flood and Signal Lights left hand	491-0637	1
	JJA, SZP, JAP, SZN, SZS, JPA, SZL, SZW, JBP, SZM	Lamp Flood	Cab Work Lights	254-8155	2
			Ripper Flood Lights	346-9593	4
	JJA, SZP, JAP, SZN, SZS, JPA, SZL, SZW, JBP, SZM	Flood lights	Rear Flood Lights	254-8155	2
	JJA, SZP, JAP, SZN, SZS, JPA, SZL, SZW, JBP, SZM	Head and Signal	Low Bar Head and Signal Lights left hand	272-6641	2
			Low Bar Head and Signal Lights Right hand	259-9287	1
	JJA, SZP, JAP, SZN, SZZ, SZS, JPA, SZL, SZW, JBP, SZM	Signal park and turn	Rooding Park and Turn Signals	259-9288	1
	JJA, SZP, JAP, SZN, SZZ, SZS, JPA, SZL, SZW, JBP, SZM	Lamp group signal LED	Rooding Left and Right Rear Signal Lights Ripper LED Signal Lights	334-5409	2
	JJA, SZP, JAP, SZN, SZZ, SZS, JPA, SZL, SZW, JBP, SZM	Lamp Signal	Rear Radiator Signal Lights	334-5410	2
	JJA, SZP, JAP, SZN, SZZ, SZS, JPA, SZL, SZW, JBP, SZM	Lamp back up	Rooding Reverse Lights Ripper Back-up Lights	334-8049	2
	JJA, SZP, JAP, SZN, SZZ, SZS, JPA, SZL, SZW, JBP, SZM	Lamp registration plate	Registration Plate Light	261-1502	2
JJA, SZP, JAP, SZN, SZZ, SZS, JPA, SZL, SZW, JBP, SZM	Registration Plate	Registration Plate Light - European	259-0134	1	
			5C-9583	1	

Sales Model	Serial Number Prefix	Fuses	Part Number
12K, 120K, 120K2, 140K, 140K2, 160K	JJA, SZP, JAP, SZN, SZZ, SZS, JPA, SZL, SZW, JBP, SZM	10 Amp - Mini	9W-1442
		15 Amp - Mini	9W-1441
		20 Amp - Mini	9W-1446

CAB GLASS AND ACCESSORIES

Sales Model	Serial Number Prefix	Description	Part Number
12K, 120K, 120K2, 140K, 140K2, 160K	JJA, SZP, JAP, SZN, SZZ, SZS, JPA, SZL, SZW, JBP, SZM	Front Upper Wiper Blade	6V-5853
		Front Lower Wiper Blade	123-4355 (Quantity 2)
		Rear Wiper Blade	6V-5853
		Top Windshield	8X-2228
		Bottom Right Windshield	149-3409
		Bottom Left Windshield	149-3409
		Right Side Glass	115-6806
		Left Side Glass	115-6806
		Upper Fixed Door Window	8X-3938
		Lower Fixed Door Window	8X-4448
		Rear Glass	102-9372
		Seat Belt	513-0286
		Washer Bottle Cover	7T-1961
		Washer Bottle Tank with Cap	8X-9675
		Washer Pump (Qty 2)	7T-8891
		Left and Right Step Ladder Bracket	512-9038 (Left) 512-9039 (Right)
		Top and Middle Individual Ladder Steps	454-7803
		Bottom Individual Ladder Steps	512-9043
		Ladder Belt Mounting Bracket	512-9040

BATTERIES

Sales Model	Serial Number Prefix	Description	Part Number	Quantity
12K, 120K, 120K2, 140K, 140K2, 160K	JJA, SZP, JAP, SZN, SZZ, SZS, JPA, SZL, SZW, JBP, SZM	Standard Battery	3T-5760	2
		12v Heavy Duty 1400-CCA Battery	153-5710	2

ENGINE PARTS

Sales Model	Serial Number Prefix	Description	New Part Number	Remanufactured Part Number	Quantity
12K	JJA, SZP	Complete Engine Arrangement	395-0486	10R-4139	1
120K	JAP, SZN		395-0485 539-8082	10R-4139 20R-1711	1
	SZN		539-8081	10R-4139 20R-1711	1
120K2	SZZ, SZS		539-8082 395-0487	11R-0101 10R-4139 10R-4139	1
140K, 140K2, 160K	JPA, SZL, SZW, JBP, SZM		511-5381	20R-1712	1
12K	JJA, SZP		Turbocharger	352-2396	20R-2947
120K, 120K2	JPA, SZL	250-7696		10R-9217	1
140K, 140K2, 160K	JPA, SZL, SZW, JBP, SZM	338-1878		20R-3130	1
12, 120K, 120K2, 140K, 140K2, 160K	JJA, SZP, JAP, SZN, SZZ, SZS, JPA, SZL, SZW, JBP, SZM	Water pump	352-2138	10R-2790	1
		Fuel Priming Pump	467-2659	-	1
12, 120, 120K, 140K, 140K2, 160K	JJA, SZP, JAP, SZN, SZZ, SZS, JPA, SZL, SZW, JBP, SZM	Pump Engine Oil	200-4497	-	1
		Pump Injector fuel	557-7627	20R-9079	1
		Hydraulic Pump Injector	476-8768	20R-1649	1
12K, 120, 120K2, 140K, 140K2, 160K	JJA, SZP, JAP, SZN, SZZ, SZS, JPA, SZL, SZW, JBP, SZM	Starter-Motor	207-1517	10R-0395	1
12, 120, 120K2, 140K, 140K2, 160K	JJA, SZP, JAP, SZN, SZZ, SZS, JPA, SZL, SZW, JBP, SZM	Alternator Charging 115 Amp	366-2756	20R-0957	1
12K, 120, 120K, 140K, 140K2, 160K	JJA, SZP, JAP, SZN, SZZ, SZS, JPA, SZL, SZW, JBP, SZM	Alternator Charging 95 Amp	197-08820	-	1
12K, 120K, 120K2, 140K, 140K2, 160K	JJA, SZP, JAP, SZN, SZZ, SZS, JPA, SZL, SZW, JBP, SZM	Compressor Refrigerent	464-9988	-	1

LINKAGE PIN AND BEARING PART NUMBERS

Circle Pins

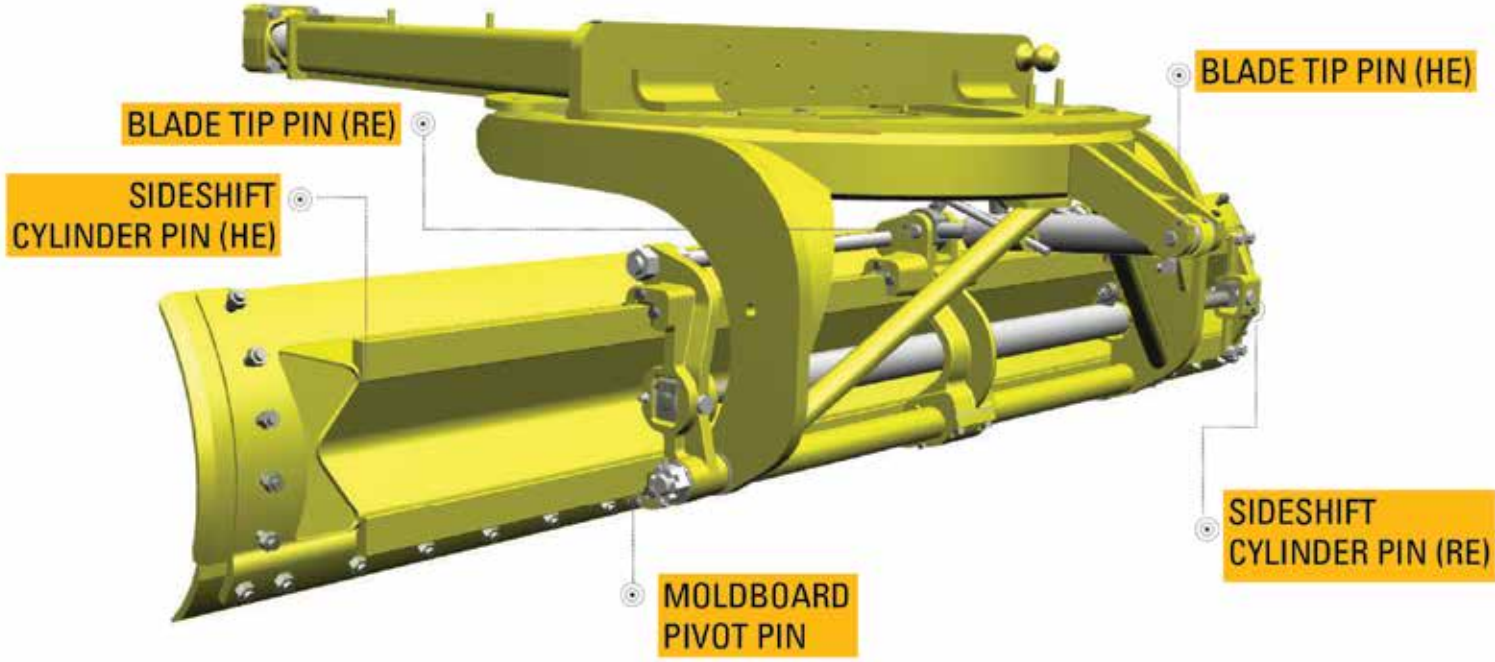

CIRCLE PINS																			
SALES MODEL	Prefix Prefix	Blade Tip Pins (HE)			Blade Tip Pin (RE)			Sideshift Cylinder Pin (RE)			Sideshift Cylinder Pin (HE)			Moldboard Pivot Pin			Lubricated Moldboard Pivot Pin		
		QTY	Part Number	Part Description	QTY	Part Number	Part Description	QTY	Part Number	Part Description	QTY	Part Number	Part Description	QTY	Part Number	Part Description	QTY	Part Number	Part Description
120K	JAP,SZN,SZS	1	293-7547	Pin	1	8D-6687	Pin	1	5T-5295	Pin	1	5T-8417	Pin	1	153-3580	Shaft	-	-	-
		1	2D-8652	Bearing	1	2D-8652	Bearing	-	-	-	-	-	-	1	6G-2947	Shaft	-	-	-
140K/ 140K2	JPA,SZL,SZW	1	293-7547	Pin	1	8D-6687	Pin	1	5T-5295	Pin	1	5T-5295	Pin	1	153-3580	Shaft	2	526-6468	Pin
		1	2D-8652	Bearing	1	293-7546	Pin	1	249-5643	Pin	1	249-5643	Pin	2	2A-7089	Bearing	8	467-5183	Bearing Sleeve
		-	-	-	1	2D-8652	Bearing	-	-	-	-	-	-	2	104-8655	Bearing	2	3B-8489	Adaptor STR
12K	JJA,SZP	1	293-7547	Pin	1	8D-6687	Pin	1	5T-5295	Pin	1	5T-5295	Pin	1	153-3580	Shaft	2	526-6468	Pin
		1	2D-8652	Bearing	1	2D-8652	Bearing	-	-	-	-	-	-	2	2A-7089	Bearing	8	467-5183	Bearing Sleeve
		-	-	-	-	-	-	-	-	-	-	-	-	2	104-8655	Bearing	2	3B-8489	Adaptor STR
160K	JBP,SZM	1	293-7547	Pin	1	8D-6687	Pin	1	5T-5295	Pin	1	5T-5295	Pin	1	153-3580	Shaft	2	526-6468	Pin
		1	2D-8652	Bearing	1	293-7546	Pin	1	249-5643	Pin	1	249-5643	Pin	1	112-1269	Shaft	8	467-5183	Bearing Sleeve
		-	-	-	1	2D-8652	Bearing	-	-	-	-	-	-	2	2A-7089	Bearing	2	3B-8489	Adaptor STR
		-	-	-	-	-	-	-	-	-	-	-	-	2	104-8655	Bearing	-	-	-



Cat Filters Provide Longer Injector Life

Chances are, you don't skip oil changes or regular maintenance on the family car. So why skip planned maintenance on your Cat equipment? Cat fuel filters outperform the competition, with up to 45% longer injector life and up to 80% decreased cost per hour.*



Productivity & Hydraulics Go Hand In Hand

If your hydraulic system isn't performing at peak efficiency, it's robbing your machine of performance. Efficiency losses usually occur slowly and can reach 20% before you detect a problem — that's one day of lost production every week! These losses can also increase your fuel consumption and operating costs.



Need help?

Your local Cat dealer can provide:

- Technical Support
- Customer Value Agreements
- Oil sample analysis
- Parts needed and equipment fit
- Repair financing
- Rental Services

Find your local dealer at www.cat.com today.



LET'S DO THE WORK.™



To buy Cat parts online, visit Parts.cat.com.

* Visit <https://www.cat.com/filtersandfluids> for more details

PEDJ1168-01
© 2023 Caterpillar. All Rights Reserved. CAT, CATERPILLAR, LET'S DO THE WORK, their respective logos, "Caterpillar Corporate Yellow", the "Power Edge" and Cat "Modern Hex" trade dress as well as corporate and product identity used herein, are trademarks of Caterpillar and may not be used without permission.

