



D3 SERIES SKID STEER LOADER, COMPACT TRACK AND MULTI TERRAIN LOADER PARTS REFERENCE GUIDE

LET'S DO THE WORK.™



» PROTECT YOUR INVESTMENT WITH GENUINE CAT® PARTS

Thank you for selecting the Cat® D3 Series Skid Steer, Compact Track or Multi Terrain Loader.

This guide is designed to provide you with a quick reference for the parts and part numbers you need to keep your Cat machine running at peak efficiency. Always read and understand the machine's Operation and Maintenance Manual prior to performing any type of maintenance.



MAINTENANCE

Preventive maintenance extends the life of your machine and protects your investment. Only Caterpillar knows Cat equipment's filtration and lubrication requirements and offers parts kits to match your machine's maintenance cycles.

SCHEDULED REPAIR PARTS	
	GREASES
	PLANNED MAINTENANCE

REPLACEMENT PARTS

Proper maintenance minimizes the need for repair and replacement. In the event that replacement parts are required, the use of genuine Cat parts helps maximize machine performance and maintains high resale value.

WEAR PARTS	
	RUBBER TRACK OFFERINGS
	FLEXPOR TIRE
	UNDERCARRIAGE PARTS
	GROUND ENGAGING TOOLS
REPAIR PARTS	
	BATTERIES
	ENGINE PARTS
	CAB GLASS
	LIGHTS
ENHANCEMENT PARTS	
	QUICK DISCONNECTS
	LINKAGE PINS, BUSHINGS AND ACCESSORIES

GREASES

Previous Cat Product Name	STANDARD MAINTENANCE GREASES		
	Cat Ultra5 Moly #1	Cat Ultra5 Moly #2	Cat Advanced 3 Moly
Current Cat Product Name	Cat Extreme Application Grease 1	Cat Extreme Application Grease 2	Cat Prime Application Grease
Grade (NLGI)	1	2	2
Melting Point C° (F°)	260 (500)	260 (500)	260 (500)
Ambient Temperature C° (F°)	-35 to +40 (-31 to +104)	30 to +50 (-22 to +122)	-20 to +40 (-4 to +104)
Base Oil Type	Mineral	Mineral	Mineral
Color	Dark Grey	Dark Grey	Dark Grey
Cartridge (390 g / 14 oz)	452-5996	452-6001	452-6006
Plastic Pail (5 kg / 11 lb)	-	-	-
Plastic Pail (16 kg / 35 lb)	452-5999	452-6004	452-6009
Keg (55 kg / 120 lb)	452-5998	452-6003	452-6008
Drum (180 kg / 400 lb)	452-5997	452-6002	452-6007



GREASES FOR UNIQUE APPLICATIONS AND ENVIRONMENTS			
Cat Arctic Platinum	Cat Desert Gold	Cat Multipurpose	Hammer Paste
Cat Extreme Application Grease - Arctic	Cat Extreme Application Grease - Desert	Cat Utility Grease	
0	2	2	2
230 (446)	280 (536)	260 (500)	230 (446)
-35 to +40 (-31 to +104)	30 to +50 (-22 to +122)	-30 to +40 (-22 to +104)	-20 to +1100 (-4 to +2012)
Semi-Synthetic	Mineral	Mineral	Mineral
Dark Grey	Dark Grey	Blue	Bronze
508-2184	452-6016	452-6011	130-6951 (standard) 317-8491 (autolube)
-	-	-	133-8807
508-2187	452-6019	452-6014	-
508-2186	452-6018	452-6013	-
508-2185	452-6017	452-6012	-



PLANNED MAINTENANCE

SKID STEER LOADER		Every 500 Hours										Every 1,000 Hours					Every 3,000 Hours		
		Engine Oil/Filter Change		Air Filter		Fuel Filter Change		Lubricate Machine	Hydraulic Tank	Cabin Air*		Cabin Air*	Engine	Hydraulic Oil Filter		Drive Chain Oil	Hydraulic Oil**		
Sales Model	Serial Number Prefix	Filter	Oil Quantity (L)	Primary Element	Secondary Element	In-line Element	Primary Element	Prime Application Grease	Breather Element	Fresh Air Element	Recirculating Element	A/C Compressor Belt	Belt	Filter Element	Seal (Housing)	Seal (Plug)	Oil Quantity (L)	Oil Quantity (L) Hydo Adv 10	
216B3	PWK, HR2, SL3, DSN, PWM	220-1523	10	231-0167	231-0168	1G-7206	156-1200	452-6006	207-9729	231-8132	303-6658	-	438-1597	1G-8878	-	-	6	35	
226B3	DXZ, F3D, NRK		9	415-2592	415-2593	-	541-6957		420-9748	265-6619	265-6618	248-3100	513-8590	421-5479	4F-4097 (Quantity 2)	117-8804	-		-
232D3	PWN		12	110-6326	110-6331				541-6957			258-2829	198-8354				5L-3979	9	13
236D3	AZ6, F9C	377-6969	12	110-6326	110-6331	-	541-6957	452-6006	258-2829	265-6619	265-6618	198-8354	5L-3979	421-5479	4F-4097 (Quantity 2)	117-8804	9	39	
242D3	R2L NXL, T8T, T8W																13		
246D3	AH6, GM6, TC7, TM7																		
262D3	MXJ, BT2, TP6, TP7																		

**Fluid Type	500 Hour S*O*S SM Services	Interval
Cat HYDO Advance 10	No	3,000
	Yes	6,000
Non-Cat HYDO Advance 10	No	2,000
	Yes	4,000

COMPACT TRACK LOADER		Initial 250 Hours	Every 500 Hours										Every 1,000 Hours					Every 3,000 Hours
		Final Drive Oil	Final Drive Oil	Engine Oil/Filter Change		Air Filter		Fuel Filter	Lubricate Machine	Hydraulic Tank	Cabin Air*		Cabin Air*	Engine	Hydraulic Oil Filter		Hydraulic Oil**	
Sales Model	Serial Number Prefix	Oil Syn GO (1 L)	Oil Syn GO (1 L)	Filter	Oil Quantity (L)	Primary Element	Secondary Element	Primary Element	Prime Application Grease	Breather Element	Fresh Air Element	Recirculating Element	A/C Compressor Belt	Belt	Filter Element	Seal (Housing)	Seal (Plug)	Oil Quantity (L) Hydo Adv 10
259D3	MC9, TLS	350-9510 (Quantity 2)	350-9510 (Quantity 2)	377-6969	12	110-6326	110-6331	541-6957	452-6006	258-2829	265-6619	265-6618	198-8354	5L-3979	421-5479	4F-4097 (Quantity 2)	117-8804	39
279D3	SZ9, TB9																	
289D3	KX9, LA9																	

*Closed cab machines only.



**Fluid Type	500 Hour S*O*S SM Services	Interval
Cat HYDO Advance 10	No	3,000
	Yes	6,000
Non-Cat HYDO Advance 10	No	2,000
	Yes	4,000

MULTI TERRAIN LOADER		Initial 250 Hours	Every 500 Hours										Every 1,000 Hours					Every 3,000 Hours
		Final Drive Oil	Final Drive Oil	Engine Oil/Filter Change		Air Filter		Fuel Filter	Lubricate Machine	Hydraulic Tank	Cabin Air*		Cabin Air*	Engine	Hydraulic Oil Filter		Hydraulic Oil**	
Sales Model	Serial Number Prefix	Oil Syn GO (1 L)	Oil Syn GO (1 L)	Filter	Oil Quantity (L)	Primary Element	Secondary Element	Primary Element	Prime Application Grease	Breather Element	Fresh Air Element	Recirculating Element	A/C Compressor Belt	Belt	Filter Element	Seal (Housing)	Seal (Plug)	Oil Quantity (L) Hydo Adv 10
257D3	FMA, LM7	350-9510 (Quantity 2)	350-9510 (Quantity 2)	377-6969	12	110-6326	110-6331	541-6957	452-6006	258-2829	265-6619	265-6618	198-8354	5L-3979	421-5479	(2) 4F-4097	117-8804	39

*Closed cab machines only.

**Fluid Type	500 Hour S*O*S SM Services	Interval
Cat HYDO Advance 10	No	3,000
	Yes	6,000
Non-Cat HYDO Advance 10	No	2,000
	Yes	4,000

RUBBER TRACK OFFERINGS

COMPACT TRACK LOADER TRACK PATTERNS				
		Heavy Duty Block	Heavy Duty Bar	General Duty
Sales Model	Machine Series	Track Part Number	Track Size - Width x Pitch x Lug Count mm (in)	Description
259	D3	592-5445 607-4803	320x86x53 (12.6x3.4x53)	320 mm (12.6") Heavy Duty Block Track
		592-5827	400x86x53 (15.7x3.4x53)	400 mm (15.7") Heavy Duty Block Track
		561-5498 607-4804	400x86x53 (15.7x3.4x53)	400 mm (15.7") Heavy Duty Bar Track
		584-7121 608-7327	320x86x53 (12.6x3.4x53)	320 mm (12.6") General Duty Track
		608-7328	400x86x53 (15.7x3.4x53)	400 mm (15.7") General Duty Track
279/289	D3	593-1012	450x86x56 (17.7x3.4x56)	450 mm (17.7) Heavy Duty Block Track
		592-5828	400x86x56 (15.7x3.4x56)	400 mm (15.7") Heavy Duty Block Track
		608-7329	450x86x56 (17.7x3.4x56)	450 mm (17.7") General Duty Track
		561-5499	450x86x56 (17.7x3.4x56)	450 mm (17.7") Heavy Duty Bar Track

MULTI TERRAIN LOADER TRACK PATTERNS				
		General Duty		
Sales Model	Machine Series	Track Part Number	Track Size - Width x Pitch x Lug Count mm (in)	Description
257	D3	420-9876 454-6087	381x100x42 (15x4x42)	381 mm (15") General Duty Track

FLEXPOR™ TIRES

Machine	Size Diameter x Rubber Thickness x Tread Width	Part Number
216B3 226B3 232D3	31x6x10 (10.00x16.5)	345-7585 329-6989 Left 329-6990 Right
236D3 242D3 246D3 262D3	33x6x11 (12.00x16.5)	324-3427 329-6785 329-6784 Left 329-6783 Right



TREAD OPTIONS

OTR (Off-the-road)

OTR tread design has a block pattern that provides a degree of traction in applications where debris is not an issue.



SMOOTH

Smooth tread design is ideal for special applications where debris is an issue like scrap yards, recycling centers and some waste transfer stations.



CONSTRUCTION

Construction tread design is the right choice for maximum performance in the toughest environments. It is designed for smaller machine applications where better traction is required.



UNDERCARRIAGE PARTS

Compact Track Loaders		Wheels		Sprockets	
Sales Model	Serial Number Prefix	Part Number	Description	Part Number	Description
259D3 279D3 289D3	MC9, TLS SZ9, TB9 KX9, LA9	536-3551	Double Flange Idler	304-1916	Sprocket
		536-3550	Single Flange Idler		
		536-3549	Triple Flange Roller		
		536-3552	Triple Flange Idler		

Multi Terrain Loaders		Wheels		Sprockets	
Sales Model	Serial Number Prefix	Part Number	Description	Part Number	Description
257D3	FMA, LM7	305-9270	Steel Rear Idler	342-5015	Outer Sleeve (Hardened)
				342-5014	Inner Sleeve (Hardened)
		278-1301	Front Idler	258-3087	Sprocket Ring
				280-5091	Sprocket Bolt
		295-3250	Front Idler (Steel)	7X-3392	Washer
				1K-6872	Locknut
		278-1261	Bogie Wheel	389-7577	Sprocket

COMMON GROUND ENGAGING TOOLS BROOM EDGES AND ACCESSORIES

Part Description	Broom Model	Part Number
Bolt-On Cutting Edge	BU115, BU115B	489-6702
Bolt-On Cutting Edge	BU115, BU115B	489-6703
Bolt-On Cutting Edge	BP115C	452-4148
Bolt-On Cutting Edge	BP118C	452-4147
Poly Bristle Assemblies (Quantity 18)	BU115, BP115B, BP115C	165-9069
Wire Bristle Assemblies (Quantity 17)	BU115, BP115B, BP115C	165-9070
Poly Bristle Assemblies (Quantity 21)	BU118, BP118B, BP118C	165-9071
Wire Bristle Assemblies (Quantity 20)	BU118, BP118B, BP118C	165-9072
Poly Bristle Assemblies (Quantity 22)	BA118, BA118C	166-0322
Wire Bristle Assemblies (Quantity 21)	BA118, BA118C	166-0323
Wire Bristle Assemblies (Gutter Brush)	All series gutter brushes	172-4563
Poly Bristle Assemblies (Gutter Brush)	All series gutter brushes	460-9777

COMMON GROUND ENGAGING TOOLS (CONTINUED) BUCKET TOOTHBARS, TEETH AND CUTTING EDGES

Part Description	Bucket Size	Bucket Type	Part Description	Part Number
Bolt-On Tooth Bar	1883 mm (74 inch)	General Purpose / Multi-Purpose – Base Edge Buckets	8 Teeth	136-8736
	2036 mm (80 inch)	General Purpose / Multi-Purpose – Base Edge Buckets	8 Teeth	217-4878
	2188 mm (86 inch)	General Purpose / Multi-Purpose – Base Edge Buckets	8 Teeth	275-5427
	1576 mm (62 inch)	General Purpose / Multi-Purpose – Bolt-On Edge Buckets	7 Teeth	159-0330
	1730 mm (68 inch)	General Purpose / Multi-Purpose – Bolt-On Edge Buckets	8 Teeth	159-0340
	1883 mm (74 inch)	General Purpose / Multi-Purpose – Bolt-On Edge Buckets	8 Teeth	159-0350
	2036 mm (80 inch)	General Purpose / Multi-Purpose – Bolt-On Edge Buckets	8 Teeth	195-9160
	2188 mm (86 inch)	General Purpose / Multi-Purpose – Bolt-On Edge Buckets	8 Teeth	264-2084
Serrated Cutting Edge	1576 mm (62 inch)	General Purpose / Multi-Purpose – Base Edge Buckets	–	319-9599
	1730 mm (68 inch)	General Purpose / Multi-Purpose – Base Edge Buckets	–	319-9600
	1883 mm (74 inch)	General Purpose / Multi-Purpose – Base Edge Buckets	–	319-9601
	2036 mm (80 inch)	General Purpose / Multi-Purpose – Base Edge Buckets	–	319-9602
	2188 mm (86 inch)	General Purpose / Multi-Purpose – Base Edge Buckets	–	319-9603
	Bolt-On Cutting Edge	1421 mm (56 inch)	Low Profile Buckets	152.4mm width, 12.7mm thickness
1421 mm (56 inch)		Low Profile Buckets	203mm width, 16mm thickness	174-7965
1421 mm (56 inch)		Low Profile Buckets	203mm width, 19mm thickness	174-7971
1576 mm (62 inch)		General Purpose / Multi-Purpose / Low Profile / Utility / Grapple Buckets	165mm width, 16mm thickness	135-9394
1576 mm (62 inch)		General Purpose / Multi-Purpose / Low Profile / Utility / Grapple Buckets	203mm width, 16mm thickness	174-7966
1576 mm (62 inch)		General Purpose / Multi-Purpose / Low Profile / Utility / Grapple Buckets	203mm width, 19mm thickness	174-7972
1730 mm (68 inch)		General Purpose / Multi-Purpose / Low Profile / Utility / Grapple Buckets	165mm width, 16mm thickness	135-9395
1730 mm (68 inch)		General Purpose / Multi-Purpose / Low Profile / Utility / Grapple Buckets	203mm width, 16mm thickness	174-7967
1730 mm (68 inch)		General Purpose / Multi-Purpose / Low Profile / Utility / Grapple Buckets	203mm width, 19mm thickness	174-7973
1883 mm (74 inch)		General Purpose / Multi-Purpose / Low Profile / Utility / Grapple / Light Material Buckets	165mm width, 16mm thickness	135-9396
1883 mm (74 inch)		General Purpose / Multi-Purpose / Low Profile / Utility / Grapple / Light Material Buckets	203mm width, 16mm thickness	174-7968
1883 mm (74 inch)		General Purpose / Multi-Purpose / Low Profile / Utility / Grapple / Light Material Buckets	203mm width, 19mm thickness	174-7974
2036 mm (80 inch)		General Purpose / Multi-Purpose / Low Profile / Light Material / Grapple Buckets	165mm width, 16mm thickness	135-9397
2036 mm (80 inch)		General Purpose / Multi-Purpose / Low Profile / Light Material / Grapple Buckets	203mm width, 16mm thickness	174-7969
2036 mm (80 inch)		General Purpose / Multi-Purpose / Low Profile / Light Material / Grapple Buckets	203mm width, 19mm thickness	174-7975
2188 mm (86 inch)		General Purpose / Multi-Purpose / Light Material Buckets / Material Handling	165mm width, 16mm thickness	195-5124
2188 mm (86 inch)		General Purpose / Multi-Purpose / Light Material Buckets / Material Handling	203mm width, 16mm thickness	174-7970
2188 mm (86 inch)		General Purpose / Multi-Purpose / Light Material Buckets / Material Handling	203mm width, 19mm thickness	174-7976
2490 mm (98 inch)		Light Material Buckets / Material Handling	165mm width, 16mm thickness	296-7602
2642 mm (104 inch)		Material Handling	165mm width, 16mm thickness	469-4306
Unitooth	General Purpose / Multi-Purpose Buckets with Bolt-On Teeth	–	132-4720	

COMMON GROUND ENGAGING TOOLS (CONTINUED)

AUGER BITS AND ACCESSORIES

Part Description	Type / Size	Part Number	
Standard Duty Bits	102 mm (4 inch)	366-7751	
	152 mm (6 inch)	153-4083	
	229 mm (9 inch)	153-4084	
	305 mm (12 inch)	153-4085	
	381 mm (15 inch)	366-7752	
	457 mm (18 inch)	153-4086	
	610 mm (24 inch)	153-4089	
	762 mm (30 inch)	217-3194	
Industrial Duty Bits	457 mm (36 inch)	153-4091	
	152 mm (6 inch)	372-0260	
	229 mm (9 inch)	372-0261	
	305 mm (12 inch)	372-0262	
	406 mm (16 inch)	372-0263	
	457 mm (18 inch)	372-0264	
	610 mm (24 inch)	372-0265	
	762 mm (30 inch)	372-0266	
	457 mm (36 inch)	372-0267	
	1067 mm (42 inch)	372-0268	
1219 mm (48 inch)	372-0269		
Industrial Rock Bits	152 mm (6 inch)	372-0270	
	229 mm (9 inch)	372-0271	
	305 mm (12 inch)	372-0272	
	406 mm (16 inch)	372-0273	
	457 mm (18 inch)	372-0274	
	508 mm (20 inch)	372-0275	
	610 mm (24 inch)	372-0276	
	762 mm (30 inch)	372-0277	
	457 mm (36 inch)	372-0278	
	Rock Drill Head Tooth	372-0289	
Teeth	Gage Tooth (Outer)	371-3694	
	Flat Tooth (Inner)	371-3690	
	Hard Face (HF) Gage Tooth (Outer)	371-3695	
	Flat Carbide Tooth (Inner)	371-3691	
	Chisel Tooth (Inner)	371-3696	
	Flat Hard Face Tooth HF (Inner)	371-3692	
	Chisel Carbide Tooth (Inner)	371-3697	
	Flat HF Tooth (HF Both Sides, Inner)	371-3693	
	Chisel HF Tooth (Inner)	371-3698	
	Standard Duty Tooth	153-4094	
Tree Bits	Hard Face Tooth	174-9566	
	Carbide Inserted Tooth	174-9567	
Rock Heads*	610 mm (24 inch)	153-4092	
	457 mm (36 inch)	153-4095	
Rock Heads*	152 mm (6 inch) Bolt-On	372-0230	
	229 mm (9 inch) Bolt-On	372-0231	
	305 mm (12 inch) Bolt-On	372-0232	
	381 mm (15 inch) Bolt-On	372-0233	
	457 mm (18 inch) Bolt-On	372-0234	
	610 mm (24 inch) Bolt-On	372-0235	
	Part Description (Continued)	Type / Size (Continued)	Part Number (Continued)
	Adapters	Hex to Round	156-6329
		Round to Hex	217-3191
	Extensions	305 mm (12 inch)	156-6328
610 mm (24 inch)		217-3192	
Telescoping Extensions	0.91 meter (3 feet)	372-0256	
	1.83 meters (6 feet)	372-0257	
Accessories	Retention Pin Kit	372-0258	
	Pilot Point	153-4093	
	Pilot Point – Industrial Rock	367-9767	



BATTERIES

Part Description	Voltage	Part Number
Standard Battery	850 CCA	230-6368
Heavy Duty	1000 CCA	115-2422

ENGINE PARTS

SKID STEER LOADER					
Sales Model	Serial Number Prefix	Starter	Alternator	Water Pump	Turbocharger
216B3	PWK, HR2, SL3, DSN, PWM	323-6614	394-3496	371-0183	-
226B3	DXZ, F3D, NRK				238-9349
232D3	PWN	423-5606	385-5044	397-9953	387-9903
236D3	AZ6, F9C				
242D3	R2L NXL, T8T, T8W				
246D3	AH6, GM6, TC7, TM7				
262D3	MXJ, BT2, TP6, TP7				

COMPACT TRACK LOADER					
Sales Model	Serial Number Prefix	Starter	Alternator	Water Pump	Turbocharger
259D3	MC9, TLS	385-5044	397-9953	387-9903	397-9979
279D3	SZ9, TB9				
289D3	KX9, LA9				

MULTI TERRAIN LOADER					
Sales Model	Serial Number Prefix	Starter	Alternator	Water Pump	Turbocharger
257D3	FMA, LM7	385-5044	397-9953	387-9903	397-9979

CAB GLASS

Part Description	Part Number	Quantity
Rearview Mirror	345-6131	1
Window – Polycarbonate Door	418-5850	1
Window – Glass Door (general use)	345-6230	1
Window Assembly – Sliding Upper Front Panel (Left)	345-6271	1
Window Assembly – Sliding Upper Front Panel (Right)	345-6274	1
Window Assembly – Sliding Upper Rear Panel (Left)	345-6270	1
Window Assembly – Sliding Upper Rear Panel (Right)	345-6275	1
Window Latch Assembly – (Left or Right)	258-3765	2
Window Assembly – Fixed Lower Panel (Left)	345-6273	1
Window Assembly – Fixed Lower Panel (Right)	345-6276	1
Window Pad – For Lower Glass (Left or Right)	435-8783	2
Window – Rear	345-6011	1
Window – Top	258-4012	1



*For use with standard bits only

LIGHTS

Part Description	Part Number	Quantity
Dome	210-8754	1
Flood – Front and Rear Working	9W-0607	4
Headlight (Roading)	9W-3324	2
Front Turn Signal (Roading)	226-4561	2
Front Position (Roading)	226-4560	2
Rear Turn Signal (Roading)	9W-3326	2
Stop and Tail (Roading)	084-4348	2
License Plate Holder (Roading)	195-9712	1
Warning Beacon	9X-8118	1
LED Kit – 2 Front and 2 Rear	499-2684	1



QUICK DISCONNECTS

Sales Model	Part Number		
	Male 1/2"	Female 1/2"	Case Drain 3/8"
B3 Series - Standard Flow	426-4052	426-4051	-
B3 Series - High Flow	373-6967	373-6968	373-7037
D3 Series - Standard Flow / High Flow			



Vertical Lift Linkage

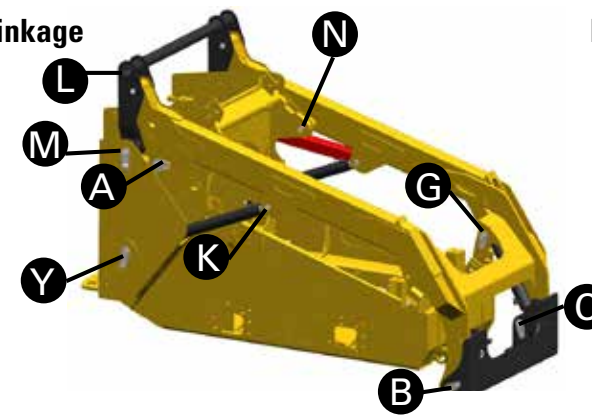

Radial Lift Linkage

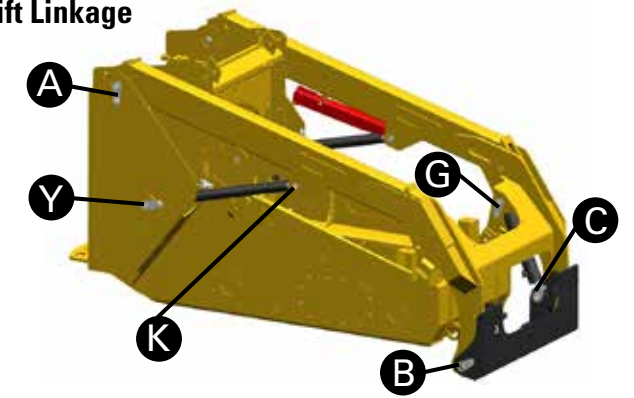

SKID STEER LOADER (SSL) LINKAGE PIN DATA

SSL Linkage Pin		Vertical Lift Linkage								
Sales Model	Serial Number Prefix	A	B	C	G	K	L	M	N	Y
232D3	PWN	435-8809 Pin (Quantity 2)	345-6511 Pin (Quantity 2)	435-8795 Pin (Quantity 2)	435-8806 Pin (Quantity 2)	258-3451 Pin (Quantity 2)	435-8808 Pin (Quantity 2)	388-7780 Pin (Quantity 2)	472-6927 Link Assembly (Quantity 2)	435-8793 Pin (Quantity 2)
242D3	R2L NXL, T8T, T8W	452-0480 Pin (Quantity 2)		142-9091 Pin (Quantity 2)	388-7776 Pin (Quantity 2)		388-7770 Pin (Quantity 2)		422-3184 Link Assembly (Quantity 2)	388-8291 Pin (Quantity 2)
262D3	MXJ, BT2, TP6, TP7	568-4601 Pin (Quantity 2)		258-2679 Pin (Quantity 2)	345-5982 Pin (Quantity 2)	345-5909 Pin (Quantity 2)	568-4603 Link Assembly (Quantity 2)	487-0045 Pin (Quantity 2)		

SSL Linkage Pin		Radial Lift Linkage					
Sales Model	Serial Number Prefix	A	B	C	G	K	Y
216B3	PWK, HR2, SL3, DSN, PWM	142-8790 Pin (Quantity 2)	191-9588 Pin (Quantity 2)	142-8791 Pin (Quantity 2)	142-8793 Pin (Quantity 2)	142-8794 Pin (Left) 142-8792 Pin (Right)	142-8790 Pin (Quantity 2)
226B3	DXZ, F3D, NRK		142-8790 Pin (Quantity 2)	142-8791 Pin (Quantity 2)	142-8793 Pin (Quantity 2)		
236D3	AZ6, F9C	388-7780 Pin (Quantity 2)	345-6511 Pin (Quantity 2)	142-9091 Pin (Quantity 2)	388-7776 Pin (Quantity 2)	258-3451 Pin (Quantity 2)	388-8291 Pin (Quantity 2)
246D3	AH6, GM6, TC7, TM7	345-5909 Pin (Quantity 2)			258-2679 Pin (Quantity 2)		493-0196 Pin (Quantity 2)

SSL Bushings		Vertical Lift Linkage			
Sales Model	Serial Number Prefix	A	B	L	M
232D3	PWN	191-9633 Bushing (Quantity 4)	6K-4148 Bushing (Quantity 4)	142-8805 Bushing (Quantity 4)	6K-4148 Bushing (Quantity 4)
242D3	R2L NXL, T8T, T8W			4K-4709 Bushing (Quantity 4)	4K-4709 Bushing (Quantity 4)
262D3	MXJ, BT2, TP6, TP7	2G-8624 Bushing (Quantity 4)			

SSL Bushings		Radial Lift Linkage	
Sales Model	Serial Number Prefix	A	B
216B3	PWK, HR2, SL3, DSN, PWM	142-8805 Bushing (Quantity 2)	159-5756 Bushing (Quantity 2)
226B3	DXZ, F3D, NRK		
236D3	AZ6, F9C	6K-4148 Bushing (Quantity 4)	6K-4148 Bushing (Quantity 4)
246D3	AH6, GM6, TC7, TM7	4K-4709 Bushing (Quantity 4)	

SKID STEER LOADER (SSL) LINKAGE PIN DATA (CONTINUED)

SSL Grease Fittings		Vertical Lift Linkage						
Sales Model	Serial Number Prefix	B	C	G	K	L	M	N
232D3	PWN	3B-8489 Grease Fitting (Quantity 2)	3B-8489 Grease Fitting (Quantity 2)	-	3B-8489 Grease Fitting (Quantity 2)	5B-0651 Straight Fitting (Quantity 2)	5B-0651 Straight Fitting (Quantity 2)	3B-8489 Grease Fitting (Quantity 2)
242D3	R2L NXL, T8T, T8W					3B-8489 Grease Fitting (Quantity 2)		-
262D3	MXJ, BT2, TP6, TP7					3B-8489 Grease Fitting (Quantity 2)		-

SSL Grease Fittings		Radial Lift Linkage						
Sales Model	Serial Number Prefix	A	B	C	G	K	Y	
216B3	PWK, HR2, SL3, DSN, PWM	3B-8489 Grease Fitting (Quantity 2)	3B-8489 Grease Fitting (Quantity 2)	3B-8489 Grease Fitting (Quantity 2)	-	3B-8489 Grease Fitting (Quantity 2)	3B-8489 Grease Fitting (Quantity 2)	
226B3	DXZ, F3D, NRK							
236D3	AZ6, F9C	5B-0651 Straight Fitting (Quantity 2)						3B-8489 Grease Fitting (Quantity 2)
246D3	AH6, GM6, TC7, TM7		3B-8489 Grease Fitting (Quantity 2)	-				

SSL Retention Hardware		Vertical Lift Linkage								
Sales Model	Serial Number Prefix	A	B	C	G	K	L	M	N	Y
232D3	PWN	119-4594 Washer (Quantity 8) 191-9738 Washer (Quantity 2) 550-6670 Screw (Quantity 2) 7X-7729 Washer (Quantity 2) 523-0657 Bolt (Quantity 2)	523-0657 Bolt (Quantity 2) 8T-4222 Washer (Quantity 2) 363-2855 Shim (Left Side only - (Quantity 5)	523-0657 Bolt (Quantity 2) 8T-4222 Washer (Quantity 2)	4S-5875 Retaining Ring (Quantity 2) 6V-7744 Locknut (Quantity 2) 8T-4198 Bolt (Quantity 2) 9R-0158 Washer (Quantity 4)	1H-8134 Retaining Ring (Quantity 4)	523-0657 Bolt (Quantity 2) 7X-7729 Washer (Quantity 2)	481-3999 Washer (Quantity 2) 523-0657 Bolt (Quantity 2)	1M-7914 Retaining Ring (Quantity 2)	308-6542 Spacer (Quantity 2) 481-3999 Washer (Quantity 2) 523-0657 Bolt (Quantity 2)
242D3	R2L NXL, T8T, T8W	119-4594 Washer (Quantity 10) 191-9738 Washer (Quantity 2) 550-6670 Screw (Quantity 2) 481-3999 Washer (Quantity 2) 523-0657 Bolt (Quantity 2) 435-8888 Spacer (Quantity 2)	523-0657 Bolt (Quantity 2) 8T-4222 Washer (Quantity 2) 363-2855 Shim (Left Side only - Quantity 5)		523-0657 Bolt (Quantity 2) 8T-4222 Washer (Quantity 2)		4M-5285 Retaining Ring (Quantity 4)		2K-5964 Retaining Ring (Quantity 2) 388-7774 Spacer (Quantity 2)	142-9142 Spacer (Quantity 2) 8T-5439 Washer (Quantity 2) 7X-7729 Washer (Quantity 2) 523-0657 Bolt (Quantity 2)
262D3	MXJ, BT2, TP6, TP7	568-4607 Plate (Quantity 2) 3B-4634 Cotter Pin (Quantity 2) 550-0805 Nut (Quantity 2) 111-4337 Washer (Quantity 2)	523-0658 Bolt (Quantity 2) 8T-4222 Washer (Quantity 2) 3S-8536 Spacer (Quantity 2) 363-2855 Shim (Left Side only - Quantity 5)		523-0657 Bolt (Quantity 2) 8T-4222 Washer (Quantity 2)		6V-7700 Retaining Ring (Quantity 4)		523-0657 Bolt (Quantity 2) 481-3999 Washer (Quantity 2)	512-3523 Washer (Quantity 2) 4S-5875 Retaining Ring (Quantity 2)

SKID STEER LOADER (SSL) LINKAGE PIN DATA (CONTINUED)

SSL Retention Hardware		Radial Lift Linkage					
Sales Model	Serial Number Prefix	A	B	C	G	K	Y
216B3	PWK, HR2, SL3, DSN, PWM	8T-4191 Bolt (Quantity 2) 7X-7729 Washer (Quantity 2)	8T-4191 Bolt (Quantity 2) 7X-7729 Washer (Quantity 2)	8T-4191 Bolt (Quantity 2) 7X-7729 Washer (Quantity 2)	8T-3647 Bolt (Quantity 2) 131-3540 Locknut (Quantity 2)	4M-5285 Retaining Ring (Quantity 2) - Each Side	8T-4191 Bolt (Quantity 2) 7X-7729 Washer (Quantity 2) 142-8808 Spacer (Quantity 2)
226B3	DXZ, F3D, NRK						
236D3	AZ6, F9C	523-0657 Bolt (Quantity 2) 481-3999 Washer (Quantity 2)	523-0657 Bolt (Quantity 2) 8T-4222 Washer (Quantity 2) 363-2855 Shim (Left Side only - Quantity 5)	523-0657 Bolt (Quantity 2) 8T-4222 Washer (Quantity 2)	523-0657 Bolt (Quantity 2) 8T-4222 Washer (Quantity 2)	1H-8134 Retaining Ring (Quantity 4)	142-9142 Spacer (Quantity 2) 481-3999 Washer (Quantity 2) 523-0657 Bolt (Quantity 2)
246D3	AH6, GM6, TC7, TM7	523-0657 Bolt (Quantity 2) 481-3999 Washer (Quantity 2)	3S-8536 Spacer (Quantity 2) 8T-4222 Washer (Quantity 2) 523-0658 Bolt (Quantity 2) 363-2855 Shim (Left Side only - Quantity 5)	523-0657 Bolt (Quantity 2) 8T-4222 Washer (Quantity 2)			523-0657 Bolt (Quantity 2) 8T-4222 Washer (Quantity 2)

COMPACT TRACK LOADER (CTL) LINKAGE PIN DATA

CTL Linkage Pin		Vertical Lift Linkage								
Sales Model	Serial Number Prefix	A	B	C	G	K	L	M	N	Y
259D3	MC9, TLS	452-0480 Pin (Quantity 2)	345-6511 Pin (Quantity 2)	142-9091 Pin (Quantity 2)	388-7776 Pin (Quantity 2)	258-3451 Pin (Quantity 2)	388-7770 Pin (Quantity 2)	388-7780 Pin (Quantity 2)	422-3184 Link Assembly (Quantity 2)	388-8291 Pin (Quantity 2)
289D3	KX9, LA9	568-4601 Pin (Quantity 2)			258-2679 Pin (Quantity 2)		345-5982 Pin (Quantity 2)	345-5909 Pin (Quantity 2)	568-4603 Link Assembly (Quantity 2)	487-0045 Pin (Quantity 2)

CTL Linkage Pin		Radial Lift Linkage					
Sales Model	Serial Number Prefix	A	B	C	G	K	Y
279D3	SZ9, TB9	345-5909 Pin (Quantity 2)	345-6511 Pin (Quantity 2)	142-9091 Pin (Quantity 2)	258-2679 Pin (Quantity 2)	258-3451 Pin (Quantity 2)	493-0196 Pin (Quantity 2)

CTL Bushings		Vertical Lift Linkage			
Sales Model	Serial Number Prefix	A	B	L	M
259D3	MC9, TLS	191-9633 Bushing (Quantity 4)	6K-4148 Bushing (Quantity 4)	142-8805 Bushing (Quantity 4)	6K-4148 Bushing (Quantity 4)
289D3	KX9, LA9	2G-8624 Bushing (Quantity 4)		4K-4709 Bushing (Quantity 4)	4K-4709 Bushing (Quantity 4)

CTL Bushings		Radial Lift Linkage	
Sales Model	Serial Number Prefix	A	B
279D3	SZ9, TB9	4K-4709 Bushing (Quantity 4)	6K-4148 Bushing (Quantity 4)

COMPACT TRACK LOADER (CTL) LINKAGE PIN DATA (CONTINUED)

CTL Grease Fittings		Vertical Lift Linkage					
Sales Model	Serial Number Prefix	B	C	G	K	L	M
259D3	MC9, TLS	3B-8489 Grease Fitting (Quantity 2)	3B-8489 Grease Fitting (Quantity 2)	-	3B-8489 Grease Fitting (Quantity 2)	3B-8489 Grease Fitting (Quantity 2)	5B-0651 Straight Fitting (Quantity 2)
289D3	KX9, LA9			3B-8489 Grease Fitting (Quantity 2)			

CTL Grease Fittings		Radial Lift Linkage				
Sales Model	Serial Number Prefix	A	B	C	G	K
279D3	SZ9, TB9	5B-0651 Straight Fitting (Quantity 2)	3B-8489 Grease Fitting (Quantity 2)	3B-8489 Grease Fitting (Quantity 2)	3B-8489 Grease Fitting (Quantity 2)	3B-8489 Grease Fitting (Quantity 2)

CTL Retention Hardware		Vertical Lift Linkage								
Sales Model	Serial Number Prefix	A	B	C	G	K	L	M	N	Y
259D3	MC9, TLS	119-4594 Washer (Quantity 10) 191-9738 Washer (Quantity 2) 550-6670 Screw (Quantity 2) 481-3999 Washer (Quantity 2) 523-0657 Bolt (Quantity 2) 435-8888 Spacer (Quantity 2)	523-0657 Bolt (Quantity 2) 8T-4222 Washer (Quantity 2) 363-2855 Shim (Left Side only - Quantity 5)	523-0657 Bolt (Quantity 2) 8T-4222 Washer (Quantity 2)	523-0657 Bolt (Quantity 2) 8T-4222 Washer (Quantity 2)	1H-8134 Retaining Ring (Quantity 4)	4M-5285 Retaining Ring (Quantity 4)	481-3999 Washer (Quantity 2) 523-0657 Bolt (Quantity 2)	2K-5964 Retaining Ring (Quantity 2) 388-7774 Spacer (Quantity 2)	142-9142 Spacer (Quantity 2) 8T-5439 Washer (Quantity 2) 7X-7729 Washer (Quantity 2) 523-0657 Bolt (Quantity 2)
289D3	KX9, LA9	568-4607 Plate (Quantity 2) 3B-4634 Cotter (Quantity 2) 550-0805 Nut (Quantity 2) 111-4337 Washer (Quantity 2)	523-0658 Bolt (Quantity 2) 8T-4222 Washer (Quantity 2) 3S-8536 Spacer (Quantity 2) 363-2855 Shim (Left Side only - Quantity 5)	523-0657 Bolt (Quantity 2) 8T-4222 Washer (Quantity 2)	523-0657 Bolt (Quantity 2) 8T-4222 Washer (Quantity 2)	1H-8134 Retaining Ring (Quantity 4)	6V-7700 Retaining Ring (Quantity 4)	481-3999 Washer (Quantity 2) 523-0657 Bolt (Quantity 2)	512-3523 Washer (Quantity 2) 4S-5875 Retaining Ring (Quantity 2)	435-8772 Spacer (Quantity 2) 523-0657 Bolt (Quantity 2) 8T-4222 Washer (Quantity 2)

CTL Retention Hardware		Radial Lift Linkage					
Sales Model	Serial Number Prefix	A	B	C	G	K	Y
279D3	SZ9, TB9	523-0657 Bolt (Quantity 2) 481-3999 Washer (Quantity 2)	3S-8536 Spacer (Quantity 2) 8T-4222 Washer (Quantity 2) 523-0658 Bolt (Quantity 2) 363-2855 Shim (Shim for Left Side only) (Quantity 5)	523-0657 Bolt (Quantity 2) 8T-4222 Washer (Quantity 2)	523-0657 Bolt (Quantity 2) 8T-4222 Washer (Quantity 2)	523-0657 Bolt (Quantity 2) 8T-4222 Washer (Quantity 2)	1H-8134 Retaining Ring (Quantity 4) 523-0657 Bolt (Quantity 2) 8T-4222 Washer (Quantity 2) 345-5429 Spacer (Quantity 2)

MULTI TERRAIN LOADER (MTL) LINKAGE PIN DATA

MTL Linkage Pin		Vertical Lift Linkage								
Sales Model	Prefix	A	B	C	G	K	L	M	N	Y
257D3	FMA, LM7	452-0480 Pin (Quantity 2)	345-6511 Pin (Quantity 2)	142-9091 Pin (Quantity 2)	388-7776 Pin (Quantity 2)	258-3451 Pin (Quantity 2)	388-7770 Pin (Quantity 2)	388-7780 Pin (Quantity 2)	422-3184 Link Assembly (Quantity 2)	388-8291 Pin (Quantity 2)

MTL Bushings		Vertical Lift Linkage			
Sales Model	Prefix	A	B	L	M
257D3	FMA, LM7	191-9633 Bushing (Quantity 4)	6K-4148 Bushing (Quantity 4)	142-8805 Bushing (Quantity 4)	6K-4148 Bushing (Quantity 4)

MTL Grease Fittings		Vertical Lift Linkage				
Sales Model	Prefix	B	C	K	L	M
257D3	FMA, LM7	3B-8489 Grease Fitting (Quantity 2)	3B-8489 Grease Fitting (Quantity 2)	3B-8489 Grease Fitting (Quantity 2)	3B-8489 Grease Fitting (Quantity 2)	5B-0651 Straight Fitting (Quantity 2)

MTL Retention Hardware		Vertical Lift Linkage								
Sales Model	Prefix	A	B	C	G	K	L	M	N	Y
257D3	FMA, LM7	119-4594 Washer (Quantity 10) 191-9738 Washer (Quantity 2) 550-6670 Screw (Quantity 2) 481-3999 Washer (Quantity 2) 523-0657 Bolt (Quantity 2) 435-8888 Spacer (Quantity 2)	523-0657 Bolt (Quantity 2) 8T-4222 Washer (Quantity 2) 363-2855 Shim (Left Side only - Quantity 5)	523-0657 Bolt (Quantity 2) 8T-4222 Washer (Quantity 2)	523-0657 Bolt (Quantity 2) 8T-4222 Washer (Quantity 2)	1H-8134 Retaining Ring (Quantity 4)	4M-5285 Retaining Ring (Quantity 4)	481-3999 Washer (Quantity 2) 523-0657 Bolt (Quantity 2)	2K-5964 Retaining Ring (Quantity 2) 388-7774 Spacer (Quantity 2)	142-9142 Spacer (Quantity 2) 8T-5439 Washer (Quantity 2) 7X-7729 Washer (Quantity 2) 523-0657 Bolt (Quantity 2)



Cat Filters Provide Longer Injector Life

Chances are, you don't skip oil changes or regular maintenance on the family car. So why skip planned maintenance on your Cat equipment? Cat fuel filters outperform the competition, with up to 45% longer injector life and up to 80% decreased cost per hour.*



Productivity and Hydraulics Go Hand In Hand

If your hydraulic system isn't performing at peak efficiency, it's robbing your machine of performance. Efficiency losses usually occur slowly and can reach 20% before you detect a problem — that's one day of lost production every week! These losses can also increase your fuel consumption and operating costs.



Need help?

Your local Cat dealer can provide:

- Technical Support
- Customer Value Agreements
- Oil sample analysis
- Parts needed and equipment fit
- Repair financing
- Rental Services



Find your local dealer at www.cat.com today.

LET'S DO THE WORK.™



To buy Cat parts online, visit Parts.cat.com.

PEDJ1050
(S Am, AME, CIS, APD-LRC Regions)
February 2023

© 2023 Caterpillar. All Rights Reserved. CAT, CATERPILLAR, LET'S DO THE WORK, their respective logos, "Caterpillar Corporate Corporate Yellow", the "Power Edge" and Cat "Modern Hex" trade dress as well as corporate and product identity used herein, are trademarks of Caterpillar and may not be used without permission.

