

R3000H

Underground Mining Loader



Engine

Engine Model	Cat® C15
Gross Power – VR Engine – SAE J1995	305 kW 409 hp
Gross Power – Equivalent to U.S. EPA Tier 3/ EU Stage IIIA – SAE J1995	305 kW 409 hp

Operating Specifications

Nominal Payload Capacity	20 000 kg	44,092 lb
Gross Machine Mass	82 000 kg	180,779 lb
Bucket Capacities		
Bucket Capacities	8.9-11.6 m ³	11.6-15.2 yd ³

R3000H Features

One Supplier

Caterpillar designed and manufactured major power and drive train components for reliability and performance.

Reliable and Durable Engine

The Cat C15 engine offers the perfect balance between power, robust design and economy.

Power Shift Transmission

Reliable and rugged design to deliver power and efficiency for peak power train performance.

Hydraulics

Perfect balance between low effort controls and powerful hydraulics for smooth and fast cycle time.

Durable Structures

The heavy duty frame is designed and built to absorb twisting, impact and high loading forces.

Comfortable Cab

Ergonomically designed for all-day comfort, control and productivity.

Enhanced Serviceability

Designed with improved service points and grouped service locations to simplify maintenance and repair.

Built in Safety

Safety is not an after thought, but an integral part of all machine and system design.

Contents

Power Train – Engine	4
Power Train – Transmission	5
Hydraulics	6
Structures.....	7
Operator Comfort	8
Loader Bucket Systems	9
Serviceability	10
Customer Support.....	11
Safety	12
Specifications.....	13
Standard Equipment.....	16
Optional Equipment.....	17
Notes.....	18





The R3000H underground loader is designed to meet the challenges of the most demanding underground mining applications. Compact design with agile performance, rugged construction and simplified maintenance ensures excellent productivity, long life and low operating costs.

Engineered for performance, designed for comfort, built to last.

Power Train – Engine

The Cat C15 engine – innovative technologies optimize performance.



The Cat C15 engine provides unequalled lugging force while digging, tramping and traversing steep grades. Torque rise effectively matches transmission shift points for maximum efficiency and fast cycle times. Mechanically Actuated, Electronic Unit Injection (MEUI™) high-pressure, direct injection fuel system electronically monitors operator demands and sensor inputs to optimize engine performance. Air-to-air aftercooling provides improved fuel economy by packing cooler, denser air into cylinders for more complete combustion of fuel and lower emissions. Oil cooled pistons increase heat dissipation and promote longer piston life. The crankshaft is forged and induction hardened for long-term durability.

The Cat C15 engine features the optional Ventilation Reduction (VR) Package. The VR Package incorporates selective engine hardware and software to reduce diesel particulate matter in the engine exhaust. Engines equipped with the VR Package feature a significant ventilation rate reduction, a decrease in fuel consumption, and maintained or improved product performance. VR Package availability is subject to regional regulatory compliance. Optional engine with emissions equivalent to U.S. EPA Tier 3 and EU Stage IIIA is also available.

A Cat Diesel Particulate Filter can be used with the VR engine package. The filter compliments the VR engine by further reductions in particulate matter. Requires the use of ultra-low sulfur diesel (15 ppm) and CJ-4 low ash engine oil.

Power Train – Transmission

More power to the ground
for greater productivity.

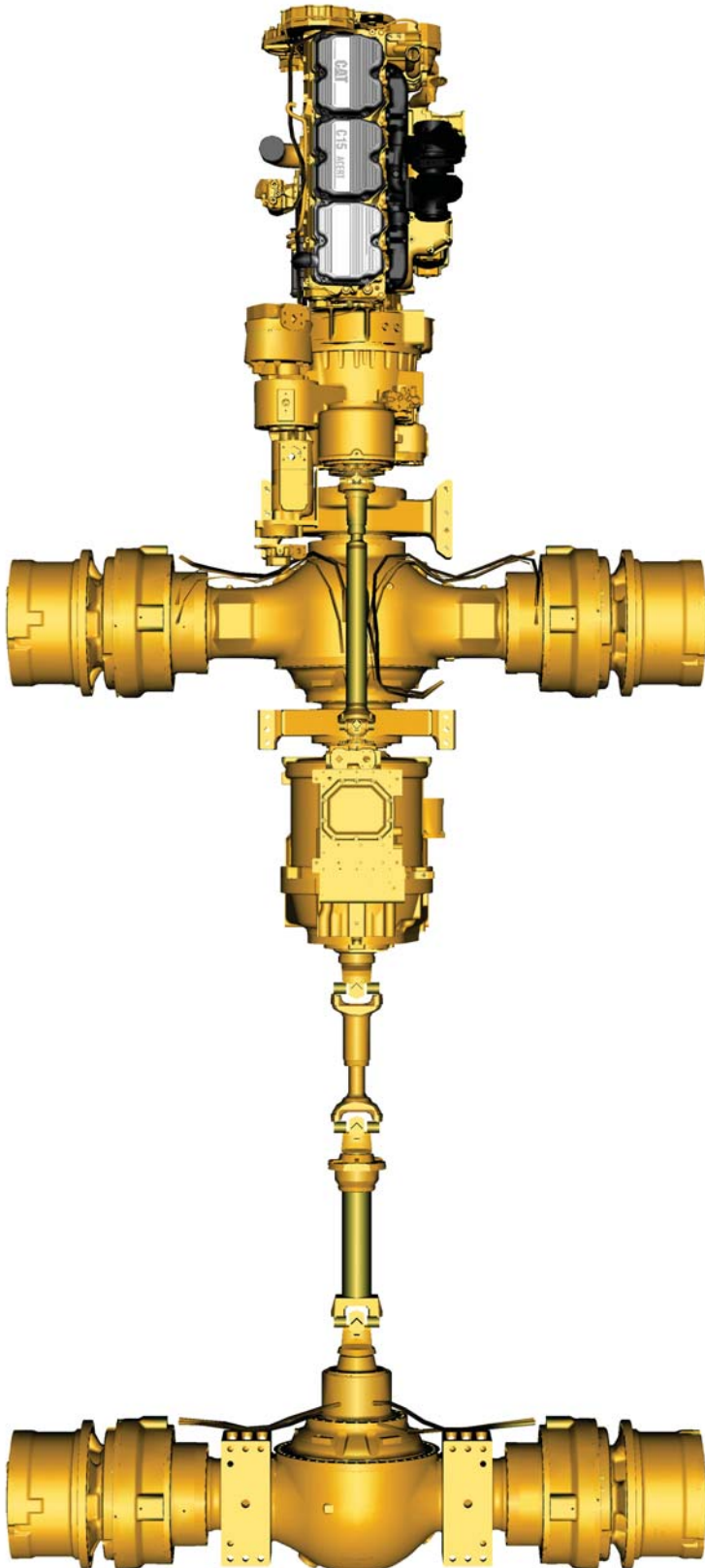

Power Shift Transmission

The Cat four-speed planetary power shift transmission is matched with the Cat C15 diesel engine to deliver constant power over a wide range of operating speeds and grades.

Robust Design

Designed for rugged underground mining conditions, the proven planetary power shift transmission is built for long life between overhauls.

Torque Converter Lockup Clutch

Combines maximum rimpull while in torque converter drive with the efficiency and performance of direct drive when the lockup clutch is engaged. The lockup clutch delivers more power to the wheels for superior power train efficiency.

Electronic Auto Shift Transmission

The electronic auto shift transmission increases operator efficiencies and optimizes machine performance. The operator can choose between manual or auto shift modes.

Transmission Neutralizer

The operator can engage the service brakes and neutralize the transmission, maintaining high engine rpm for full hydraulic flow, enhancing digging and loading functions.

Final Drives

Cat final drives work as a system with the planetary power shift transmission to deliver maximum power to the ground. Built to withstand the forces of high torque and impact loads, double reduction final drives provide high torque multiplication to further reduce drive train stress.

Hydraulics

Cat hydraulics deliver the power and control to keep material moving.



Hydraulic System

Powerful Cat hydraulics deliver exceptional digging and lifting forces for fast cycle times. High hydraulic flow rates provide fast hydraulic cylinder response and powerful lift forces. Large-bore lift and tilt cylinder delivers exceptional strength, performance and durability.

Pilot Controls

Low effort, pilot operated joystick implement control with simultaneous lift and tilt functions optimizes operating efficiency.

Cat Hydraulic Hose

Field proven Cat high pressure XT™ hydraulic hoses are exceptionally strong and flexible for maximum system reliability and long life in the most demanding conditions. Reusable couplings with O-ring face seals provide superior, leak free performance.

Optional Ride Control

The optional ride control system uses a nitrogen filled oil accumulator in the hydraulic lift circuit to act as a shock absorber for the bucket and lift arms. The lift arm and bucket response to movement is dampened over rough ground, reducing fore and aft pitch, improving cycle times and load retention. A smoother, more comfortable ride gives operators the confidence to travel at speeds above 5 km/h (3 mph) during load and carry operations.

Structures

Rugged Cat structures – the backbone of the R3000H's durability.

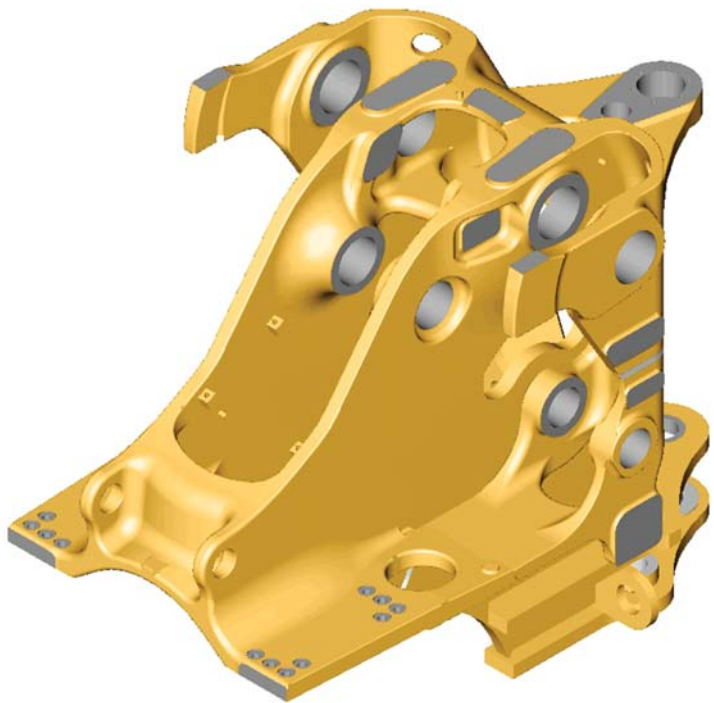

Frame Design

The frame is engineered to withstand extreme forces generated during loading and tramming cycles. Precision manufacturing process ensures all structures are consistently built to high quality. Deep penetration and consistent welds throughout the frame ensures structures are solidly fused to provide sturdy platform for the linkage and the axles. The design and manufacturing quality of Cat LHD frames have been proven by our customers, many of whom reuse frames during machine rebuilds to get 2nd and 3rd lives out of their LHD's.

Hitch

Spread hitch design widens the distance between upper and lower hitch plates to distribute forces and increase bearing life. Thicker hitch plates reduce deflection. The wide opening provides easy service access. Upper and lower hitch pins pivot on roller bearings to distribute horizontal and vertical loads over a greater surface area. Shim adjusted preload reduces maintenance time. An on-board steering frame lock pin is fitted to prevent articulation during maintenance and service.

Sealed Pins

Sealed colleted pins are fitted to all major bucket and lift arm hinge points for longer pin and bushing life. This reduces maintenance costs and extends service intervals. The sealed joints retain lubrication and prevent contaminant entry.

Z-bar Loader Linkage

Proven Z-bar loader linkage geometry generates powerful breakout force and an increased rack back angle for better bucket loading and material retention. Heavy duty steel lift arms with cast steel cross tube ensures extreme loads encountered during loading and tramming are efficiently dissipated for long service life.

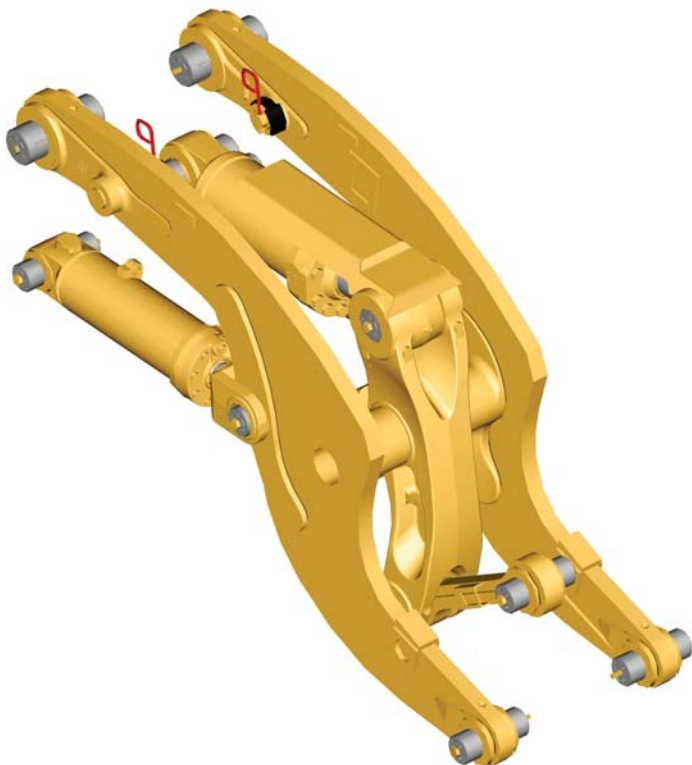

Operator Comfort

Ergonomically designed for all-day comfort, control and productivity.

The operator station is ergonomically designed for total machine control in a comfortable, productive and safe environment. All controls, levers, switches and gauges are positioned to maximize productivity and minimize operator fatigue.

Protective Structure

Integral to the cab and frame, the resiliently mounted Roll Over Protective Structure (ROPS) and the Falling Objects Protective Structure (FOPS), isolates the operator from vibration for a more comfortable ride.

Optional Enclosed Cab

Optional sound-suppressed ROPS cab provides a quiet, secure working environment. Large window openings offer excellent visibility in all directions. Air conditioning provides filtered, pressurized, temperature-controlled air for a more comfortable working environment.

STIC™ Steering and Transmission Integrated Control

STIC provides effortless control of the machine by a single controller. Simple side-to-side motion articulates the machine. Directional shifting (forward/neutral/reverse) is controlled using a three position rocker switch. The thumb operated buttons control gear selection.

Monitoring System

Cat Electronic Monitoring System (Cat EMS) continuously provides critical machine data to keep the machine performing at top production levels.





Loader Bucket Systems

Rugged performance and reliability in tough underground mining applications.

Buckets

Cat LHD buckets deliver unmatched productivity and structural reliability to help lower your cost-per-ton. Buckets are available in a range of sizes to suit most material types and densities.



Optional Wear Packages

Weld-on wear plates in high wear areas are standard. Additional wear packages, including sacrificial wear strips and Cat heel shrouds protect the edges from damage and reduce the need for costly bucket rebuilds.

Optional Cutting Edges

Cat half arrow and cast half arrow cutting edges extend bucket life in high wear applications.

An additional weld on GET option is the Cat weld-on GET. Available weld-on GET offers more wear material to maximize system wear life and bucket protection. Downtime is also reduced by an even wear rate between corners and edge segments, allowing both to be replaced at the same time.

The Cat Bolt-on Half Arrow (BOHA) GET System is another available GET option, designed for extreme conditions in abrasive environments. This system provides a longer component life and a highly reduced replacement time compared to Weld-on systems, allowing the machine to go back in production quicker.

Cat Mechanically Attached Shrouds (MAS) are also available on the R3000H buckets to provide a non weld on option for hardware selection to better suit your application.

The MAS can be further protected with the installation of the Cat Mechanically Attached Wear Plates System (MAWPS) to protect the bucket base and cutting edge.



Serviceability

More time for production.

Service Access

Easy access to daily service points simplifies servicing and reduces time spent on regular maintenance procedures.

Ground-Level Access

Allows convenient servicing to all tanks, power train filters, lubrication points and compartment drains.

Air Filters

Radial seal air filters are easy to change, reducing time required for air filter maintenance.

Sight Gauges

Fluid level checks are made easier with sight gauges.

Diagnostics

Caterpillar Electronic Technician (Cat ET) service tool enables quick electronic diagnosis of machine performance and key diagnostic data for effective maintenance and repairs.

Sealed Electrical Connectors

Electrical connectors are sealed to lock out dust and moisture. Harnesses are covered for protection. Wires are color and number coded for easy diagnosis and repair.

Scheduled Oil Sampling

S-O-SSM helps avoid minor repairs becoming major ones.





Customer Support

Cat dealer services keep underground mining equipment productive.

Dealer Capability

Cat dealers will provide the level of support you need, on a global scale. Dealer expert technicians have the knowledge, experience, training and tooling to handle your repair and maintenance needs, when and where you need them.

Product Support

When Cat products reach the field, they are supported 24/7 by a worldwide network of reliable and prompt parts distribution facilities, dealer service centers, and technical training facilities to keep your equipment up and running.

Service Support

Cat equipment is designed and built to provide maximum productivity and operating economy throughout its working life. Cat dealers will be with you every step of the way with its unsurpassed worldwide parts support, trained technicians and customer support agreements.

Technology Products

Cat dealers offer a range of advanced technology products designed to improve efficiency, productivity and lower costs. VIMS™ Gen 3 and Command for Underground options available from factory.

Replacement

Repair or rebuild? Your Cat dealer can help you evaluate the costs so you can make the right choice.

Safety

Cat mining machines and systems are designed with safety as their first priority.

Product Safety

Caterpillar has been and continues to be proactive in developing mining machines that meet or exceed safety standards. Safety is an integral part of all machine and systems designs.

Engine Shut Off Switch

A secondary engine shutoff switch is located at ground level.

Integral ROPS Cab

Integral to the cab and frame, the ROPS is resiliently mounted to the frame to isolate the operator from vibration for a more comfortable ride.

Brake Systems

Four corner oil-cooled braking system provides excellent control. The service brake system is actuated by modulated hydraulic pressure, while the parking break function is spring applied and hydraulic released. This system assures braking in the event of loss of hydraulic failure.

Standard Safety Features

Anti-skid upper deck surfaces, lower cab light, ground level compartment sight glasses, increased visibility, 3-point access to cab and machine, push out safety glass, suspension seat, inertia reel retractable seat belt, bucket control group safety pins, hot and cold side of engine, articulation lock, hinged belly guards.

SAFETY.CAT.COM™

For more complete information on safety, please visit www.cat.com/safety.

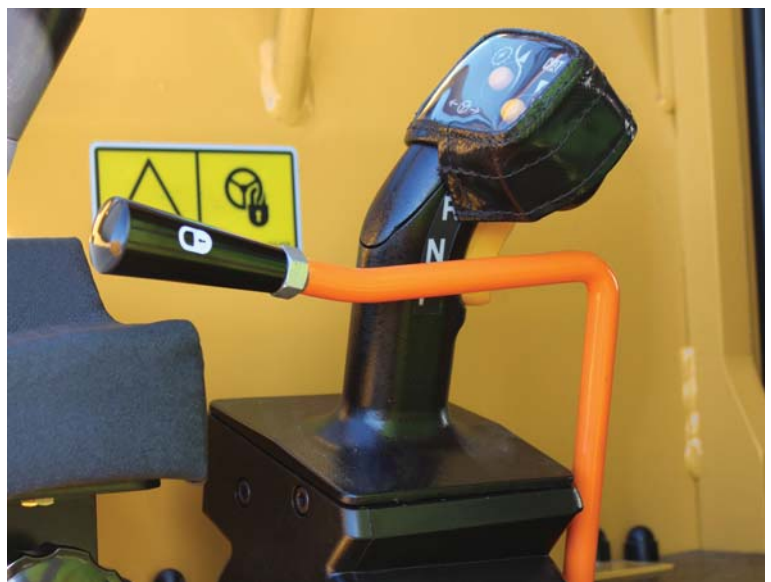

R3000H Underground Mining Loader Specifications

Engine

Engine Model	Cat C15	
Gross Power – VR Engine – SAE J1995	305 kW	409 hp
Gross Power – Tier 3 Engine – SAE J1995	305 kW	409 hp
Bore	137.2 mm	5.4 in
Stroke	171.5 mm	6.8 in
Displacement	15.2 L	927.6 in ³

- Power ratings apply at a rated speed of 1,800 rpm when tested under the reference conditions for the specified standard.
- Ratings based on ISO 14396 standard air conditions of 25° C (77° F) and 100 kPa (29.61 inHg) barometer. Power based on fuel having API gravity of 35 at 16° C (60° F) and an LHV of 42 780 kJ/kg (18,390 BTU/lb) when engine used at 30° C (86° F).
- No engine derating required up to 3050 m (10,006 ft) altitude for equivalent Tier 3 engines, and 3506 m (11,502 ft) for VR engines.
- Optional Ventilation Reduction package available.
- Optional engine with emissions equivalent to U.S. EPA Tier 3 and EU stage IIIA is also available.

Operating Specifications

Gross Machine Mass	82 000 kg	180,779 lb
Static Tipping Load Straight Ahead Lift Arms Horizontal	47 264 kg	104,199 lb
Static Tipping Full Turn Ahead Lift Arms Horizontal	40 003 kg	88,191 lb
Breakout Force (SAE)	28 020 kg	61,773 lb

Weights

Empty	58 263 kg	128,448 lb
Front Axle	24 747 kg	54,558 lb
Rear Axle	33 499 kg	73,853 lb
Loaded	78 263 kg	172,540 lb
Front Axle	56 784 kg	125,187 lb
Rear Axle	21 462 kg	47,316 lb

Transmission

Forward 1	4.9 km/h	3 mph
Forward 2	9.1 km/h	5.7 mph
Forward 3	16.4 km/h	10.2 mph
Forward 4	28.2 km/h	17.5 mph
Reverse 1	6.6 km/h	4.1 mph
Reverse 2	11.5 km/h	7.1 mph
Reverse 3	20.5 km/h	12.7 mph
Reverse 4	31.3 km/h	19.4 mph

Hydraulic Cycle Time

Raise	8.8 Seconds
Dump	1.85 Seconds
Lower, Empty, Float Down	3.54 Seconds
Total Cycle Time	14.2 Seconds

Bucket Capacities

Dump Bucket – 1 (Standard Bucket)	8.9 m ³	11.6 yd ³
Dump Bucket – 2	9.5 m ³	12.4 yd ³
Dump Bucket – 3	10.5 m ³	13.7 yd ³
Light Material Bucket	11.6 m ³	15.2 yd ³

Turning Dimensions

Outside Clearance Radius**	7536 mm	296.7 in
Inner Clearance Radius**	3247 mm	127.8 in
Axle Oscillation	8°	
Articulation Angle	42.5°	

**Clearance dimensions are for reference only.

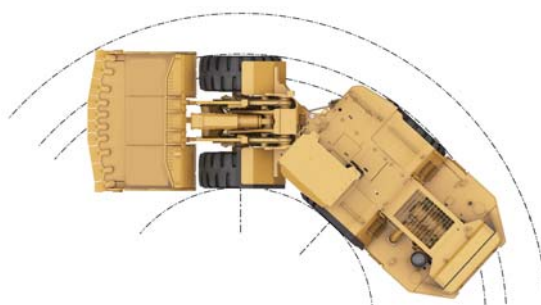

Tires

Tire Size	35/65 R33 VSNT
-----------	----------------

Service Refill Capacities

Engine Crankcase	34 L	9 gal
Transmission	62 L	16.4 gal
Hydraulic Tank	140 L	37 gal
Cooling System	75 L	19.8 gal
Front Differential and Final Drives	119 L	31.4 gal
Rear Differential and Final Drives	127 L	33.5 gal
Front Differential and Final Drives (with Axle Oil Cooling System)	159 L	42 gal
Rear Differential and Final Drives (with Axle Oil Cooling System)	167 L	44.1 gal
Fuel Tank	1539 L	406.5 gal

Standards

ROPS/FOPS Certified Cab

R3000H Underground Mining Loader Specifications

Dimensions

All dimensions are approximate.

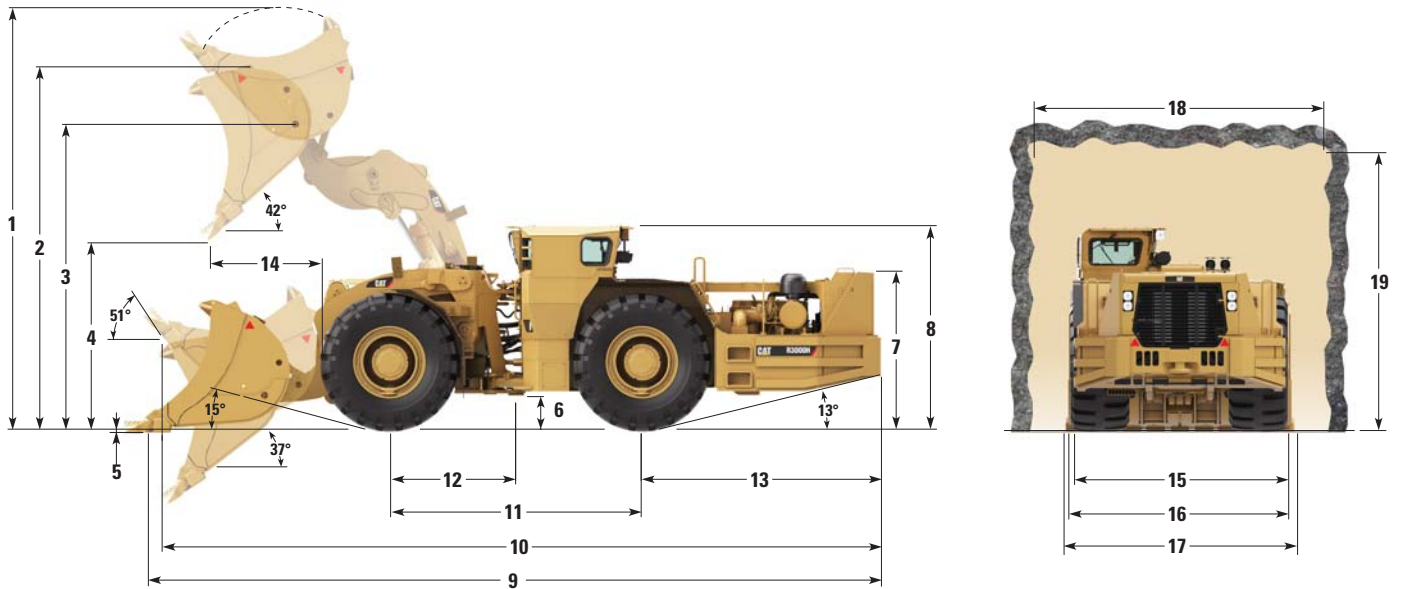

	356-1320		524-6458		372-1680		372-1695	
	Dump Bucket		Dump Bucket		Dump Bucket		Dump Bucket	
Bucket Capacity	8.9 m ³	11.6 yd ³	9.5 m ³	12.4 yd ³	10.5 m ³	13.7 yd ³	11.6 m ³	15.2 yd ³
	mm	in	mm	in	mm	in	mm	in
Bucket Width over Cutting Edge	3354	132.0	3476	136.9	3454	136.0	3754	147.8
1 Height – Bucket Raised	6283	247.4	6283	247.4	6344	249.8	6344	249.8
2 Height – Max Dump	5408	212.9	5445	214.4	5408	212.9	5429	213.7
3 Height – Max Lift Bucket Pin	4553	179.3	4553	179.3	4553	179.3	4553	179.3
4 Height – Dump Clearance at Max Lift	2744	108.0	2741	107.9	2553	100.3	2635	103.7
5 Height – Digging Depth	48.4	1.9	50	2.0	178	7.0	178	7.0
6 Height – Ground Clearance	476	18.7	476	18.7	476	18.7	476	18.7
7 Height – Top of Hood	2388	94.0	2388	94.0	2388	94.0	2388	94.0
8 Height – Top of ROPS	3002	118.2	3002	118.2	3002	118.2	3002	118.2
9 Length – Overall (Digging)	11 493	452.5	11 506	453.4	11 632	458.0	11 500	452.8
10 Length – Overall (Tramming)	11 150	439.0	11 163	439.5	11 341	446.5	11 260	443.3
11 Length – Wheelbase	3780	148.8	3780	148.8	3780	148.8	3780	148.8
12 Length – Front Axle to Hitch	1890	74.4	1890	74.4	1890	74.4	1890	74.4
13 Length – Rear Axle to Bumper	3582	141.0	3582	141.0	3582	141.0	3582	141.0
14 Length – Reach	1789	70.4	1812	71.3	1822	71.7	1719	67.7
15 Width – Machine without Bucket	3200	126.0	3200	126.0	3200	126.0	3200	126.0
16 Width – Overall Tire	3266	128.6	3266	128.6	3266	128.6	3266	128.6
17 Width – Machine with Bucket	3454	136.0	3576	140.8	3554	139.9	3854	151.7
18 Recommended Clearance Width	5000	196.9	5000	196.9	5000	196.9	5000	196.9
19 Recommended Clearance Height	4500	177.2	4500	177.2	4500	177.2	4500	177.2

R3000H Underground Mining Loader Specifications

Gradeability/Speed/Rimpull

To determine gradeability performance: Read from gross weight down to the percent of total resistance. Total resistance equals actual percent grade plus rolling resistance. As a general guide use 2% for rolling resistance in underground applications or refer to the Caterpillar Performance Handbook. From the total resistance point, read horizontally to the curve with the highest obtainable gear, then down to maximum speed. Usable rimpull will depend upon traction available and weight on drive wheels.

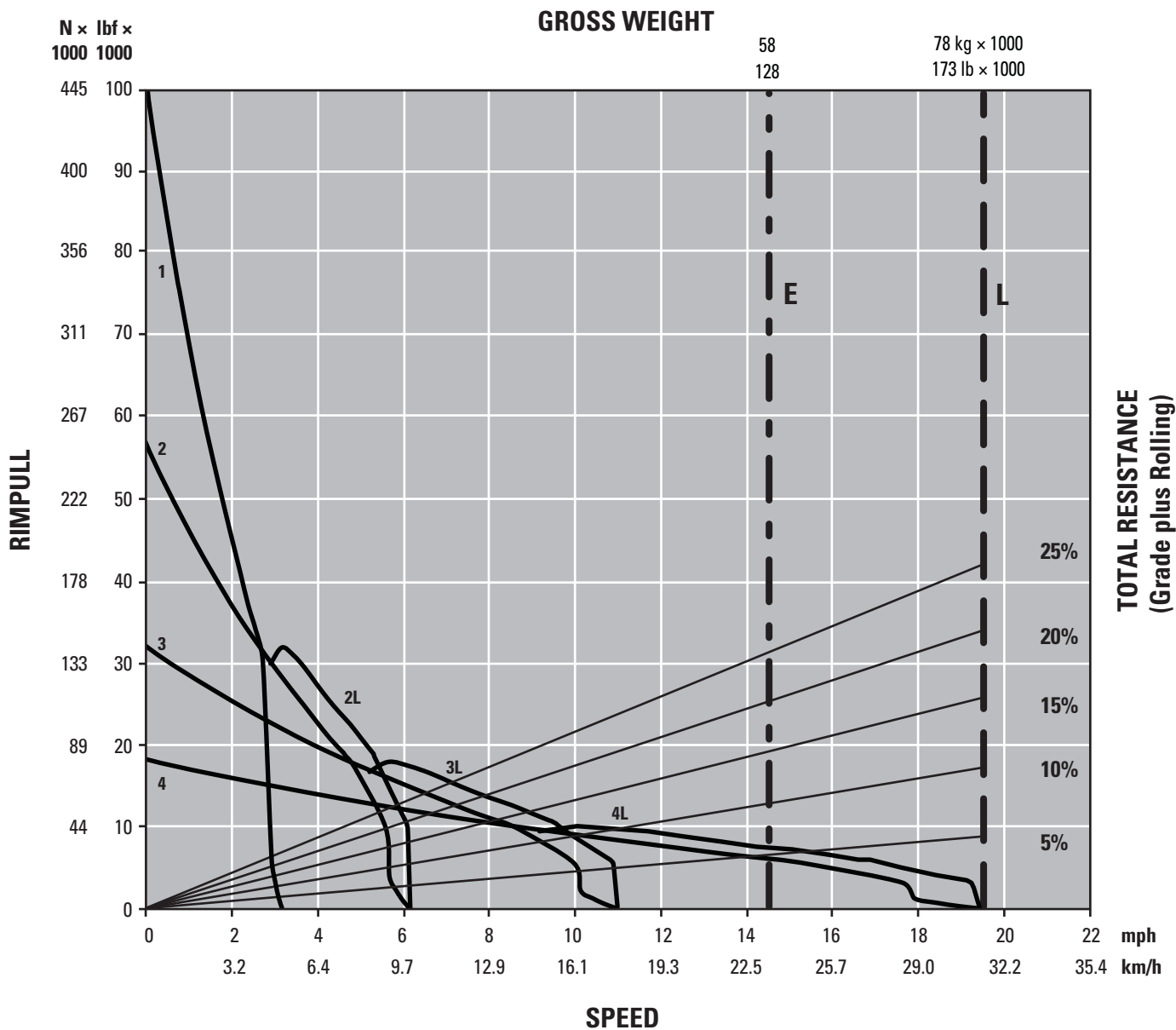

- KEY**
- 1 – 1st Gear
 - 2 – 2nd Gear
 - 2L – 2nd Gear (Lockup Clutch)
 - 3 – 3rd Gear
 - 3L – 3rd Gear (Lockup Clutch)
 - 4 – 4th Gear
 - 4L – 4th Gear (Lockup Clutch)

- KEY**
- E – Empty 58 263 kg (128,448 lb)
 - L – Loaded 78 263 kg (172,540 lb)

R3000H Standard Equipment

Standard Equipment

Standard equipment may vary. Consult your Cat dealer for details.

ELECTRICAL

- 12V Power Supply in Cab
- Alternator, 95-amp
- Auxiliary Start Receptacle
- Battery Disconnect Switch, Ground Level
- Circuit Breaker, 80-amp
- Corrosive Protection Spray
- Diagnostic Connector
- Electric Starting, 24-volt
- Engine Shutdown Switches
 - Rear Right Hand Side
- External Lighting System, Front, Rear, Halogen Work Lights
- Low Maintenance Batteries
- Reversing Alarm
- Starting and Charging System

OPERATOR ENVIRONMENT

- Cat Electronic Monitoring System (Cat EMS)
- Electric Horns
- Gauges
 - Engine Coolant Temperature
 - Transmission Coolant Temperature
 - Hydraulic Oil Temperature
 - Fuel Level
 - Speedometer
 - Tachometer
- Indicator Lights
 - Alert Warning Light
 - Residual Brake Pressure
- Low Hydraulic Level Warning
- Operators Station, Enclosed ROPS/FOPS Structure
 - Air Conditioning
 - Cab Pressurizer and Filter
 - Dome Light
 - Heater
 - Radio Ready Compartment for Radio and Speakers
- Operator Presence System (Auto Park Brake)
- Pilot Hydraulic Implement Controls, Single Joystick
- Push Button Panel for Lights
- Suspension Seat with Retractable Seat Belt
- STIC Steering

POWER TRAIN

- Cat C15 ATAAC Diesel Engine, 6-Cylinder
- Brake Axle Cooling
- Electric Fuel Priming Pump
- Engine Air Intake Precleaner
- Engine Oil Filter, Remote Mounted
- Heat Shields
- Long Life Coolant
- Planetary Powershift Transmission with Automatic Shift Control, 4 Speed Forward/4 Speed Reverse
- Radiator, Cross Flow
- Radiator Cap Manual Release
- Rims, 5-Piece, Tubeless
- SAFR™ Full Hydraulic Enclosed Wet Multiple-Disc Brakes
- Torque Converter with Automatic Lockup Clutch
- Transmission Neutralizer
- Transmission Filter Drain Tap

OTHER STANDARD EQUIPMENT

- Brake Light
- Bucket, Dump
- Bucket Lip, Hardox 450 Bucket
- Bucket Positioner, Return to Dig
- Catalytic Exhaust Purifier/Muffler Group
- Decals, International Picto Graphics
- Fuel System
 - Dual Fuel Tanks
 - Fuel System Manual Shut Off Taps
- Engine and Transmission Belly Guards
- Fenders, Front, Rear
- Firewall
- Hand Hold (Access On/Off Top Deck)
- Operation and Maintenance Manual – English and other applicable local languages to select
- Protection Wear Bars 100 × 50 mm (4 × 2 in)
- Semi Centralized Lubrication Points
- S·O·S port
 - Coolant
 - Engine Oil
 - Hydraulic Oil
 - Transmission Oil
- Swing Out Radiator Grill
- Tires and Rims: A tire must be selected from the mandatory attachments section of the machine price list. Base machine price includes a standard tubeless rim allowance only.

Optional Equipment

Optional equipment may vary. Consult your Cat dealer for details.

- Battery and Engine Shutdown Switches
 - Ground Level Isolation, In Cab Isolation Switch
 - Ground Level Isolation, Secondary Engine Shutdown Switch
 - Ground Level Isolation, In Cab Isolation, Engine Shutdown Switch
- Brake Pressure Gauges
- Brake Release Arrangements
 - Recovery Hook
 - Recovery Bar
- Buckets
 - Bucket, Light Weight Material (11.6 m³/15.2 yd³)
 - Bucket Standard Profile (8.9 m³/11.6 yd³ to 10.5 m³/13.7 yd³)
 - Bucket Spill Guard
- Bucket Hardware
 - Cutting Edge, Cat Weld On
 - Cutting Edge, Half Arrow, Flat
 - Cutting Edge, Bolt-On
 - Heel Shrouds
 - Mechanical Attached Shroud (MAS)
 - Mechanically Attached Wear Plate System, Cutting Edge Protection (MAWPS)
 - Mechanically Attached Wear Plate System, Bottom Protection (MAWPS)
 - Protector Pads (Bottom of Bucket)
 - Wear Bars
 - Wear Liner (for use with standard profile buckets)
- Bucket Lip
 - Lip Fully Welded or Tack Welded
 - Lip Bare (No Hardware)
- Bolt-On Lip
 - MAS Ready (Mechanically Attached Shrouds)
- Camera, Color Rear Facing
- Cover, Anti Vandalism for Shipping
- Drawbar Attachment, Bolt-On
- Engine Options
 - Engine, Ventilation Reduction (VR)
 - Engine, Equivalent to Tier 3
 - After-treatment options (for use with VR Engine only)
 - DPF (Flow Through)
 - DPF (Wall Flow)
- Lighting
 - External Lighting System, Front, Rear, LED Work Lights
 - High/Low Beam Function
- Fast Fill System
 - Coolant
 - Engine Oil
 - Fuel (Dual Tanks)
 - Hydraulic Oil
 - Transmission Oil
- Fire Suppression System
 - Foam, Water Based
 - Ansul, Dry Powder
- Fluids
 - Arctic Coolant
 - Arctic Fuel
- Front Light Protectors
- Fuel System
 - Fuel Lines Double Braided (Stainless Sleeving)
 - Fuel Lines Standard Braided (Double Braid Hydraulic Hose)
- Guard, Rear Side Quarter Window
- Handrails
 - Hand Hold (Access On/Off Top Deck)
 - Fold Down
- Hydraulic System
 - Alternate Implement/Pilot Control Configuration
- Lubrication System
 - Automatic
 - Centralized
- Operators Station
 - Strut, Cab Door
- Park Brake Switch Engagement
 - Push to Apply
 - Pull to Apply
- Payload Control System
 - Loadrite L2180
- Remote Control Interface (excludes Transmitter and Receiver)
 - RCT
- Reversible Steering
- Reflective Tape
- Ride Control System
- Rim
 - Rim Identification Numbering
 - Spare (Tubeless)
- Seats
 - Seat Covers, Tee, Air and Standard
 - Suspension Seat Tee, Vinyl
 - Suspension Seat Air Vinyl
- Secondary Steering System
- Service Tools
 - Brake Wear Gauge
 - Collet Jacking Bolts
 - Diagnostics Box
 - Recovery Bar (for use with Brake Release, Recovery Bar System)
 - Socket Extension, Wheel Nut
 - Reference Parts Manual for Additional Tooling Available
- Switches
 - Additional Engine Shutdown, Mounted LHS
 - Idle Timer
- Technology
 - Command for Underground
 - Vital Information Management System (VIMS) Gen 3
- Tire Arrangements
 - Tire, 35/65 R33 VSNT Bridgestone
 - Tire, 35/65 R33 VSDL Bridgestone
- Wear Protection Bars
 - Cab/ROPS
 - Hydraulic Tank
 - Radiator
- Windows
 - Single Pane
 - Dual Pane
- NOTE: Not all features are available in all regions.
- See your Cat dealer for more information.

For more complete information on Cat products, dealer services, and industry solutions, visit us on the web at www.cat.com

AEHQ6809-05 (01-2019)
Replaces AEHQ6809-04

© 2019 Caterpillar
All rights reserved

Materials and specifications are subject to change without notice. Featured machines in photos may include additional equipment. See your Cat dealer for available options.

CAT, CATERPILLAR, LET'S DO THE WORK, their respective logos, "Caterpillar Yellow", the "Power Edge" and Cat "Modern Hex" trade dress as well as corporate and product identity used herein, are trademarks of Caterpillar and may not be used without permission.

