

# 426

## BACKHOE LOADER



---

**Cat® 3054C Engine (standard)**

Engine Power 68.5 kW (93 hp)

**Weights**

Operating Weight 8425 kg

**Backhoe Digging Depth**

Dig Depth 4707 mm

E-Stick Retracted 4756 mm

E-Stick Extended 5697 mm





Caterpillar has a well proven history in the construction equipment industry and has been producing the highest quality machines for 90 years, making progress possible and driving positive and sustainable change on every continent. For over 35 years, from the A Series to current product we have produced backhoe loaders that are designed with the operator in mind, providing reliability, power and a quality operator environment. The Cat® 426 Backhoe Loader continues this tradition, providing a machine to help you grow your business.

# THE NEW CAT® 426

TAKE CONTROL IN YOUR NEW  
BACKHOE LOADER



## MORE CONTROL FOR YOU

- + **CAB AND CONTROLS** – THE SPACIOUS CAB ON THE CAT BACKHOE LOADER PROVIDES A COMFORTABLE AND EASY TO USE OPERATOR ENVIRONMENT WITH EXCELLENT VISIBILITY.
- + **POWERFUL HYDRAULICS** – THE 426 BACKHOE LOADER REALLY MAKES AN IMPACT. HIGH PUMP FLOW IN A SUPERIOR HYDRAULIC SYSTEM DELIVERS EXCELLENT HYDRAULIC PERFORMANCE AT THE OPERATOR'S FINGERTIPS.
- + **PRODUCT LINK™** – PRODUCT LINK HELPS YOU TO GET THE MOST FROM YOUR CAT BACKHOE LOADER, PROVIDING REMOTE REPORTING OF MACHINE INFORMATION SUCH AS LOCATION AND HOURS.

# OPERATOR STATION

EVERYONE CAN GET COMFORTABLE IN THIS CAB.

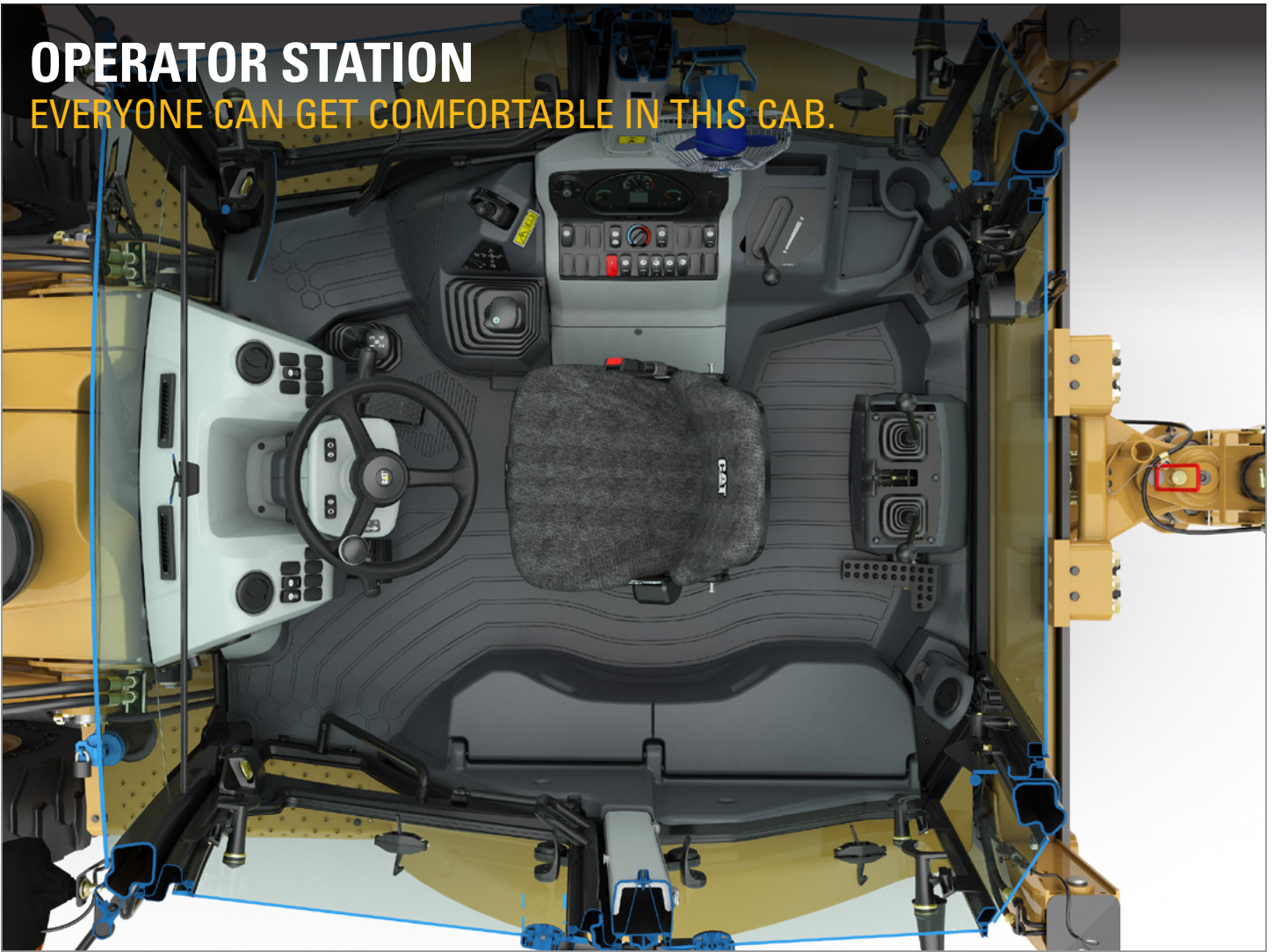

## ALL DAY COMFORT

The operator station on the 426 is designed to provide maximum comfort, ease of operation and all day comfort for today's demanding operator. Designed specifically for the market, the 426 cab features a spacious interior, flat glass and excellent visibility. The cab is spacious allowing the operator to freely move when turning from one mode of operation to another. Excellent ergonomics ensure that all controls are within easy reach of the operator, with a tiltable steering column and arm rests available as optional upgrades. Other features include additional storage space, large vents throughout the cab and clear gauges that provide information to the operator to help maximize the machine's performance. Tinted glass is offered as standard to keep operators comfortable in all environments.





## POWER TRAIN

# POWERFUL PERFORMANCE.

## POWER TRAIN

The 426 features the Cat 3054C engine (U.S. EPA Tier 2/EU Stage II equivalent) as standard and the Cat C4.4 engine (U.S. EPA Tier 3/EU Stage IIIA equivalent) as optional. The engine is a four cylinder, four stroke direct injection turbo, equipped with standard glow plug starting for optimal cold weather performance. This provides reliable starting performance down to  $-26^{\circ}$  C. An optional cold weather pack is available giving reliable starting performance down to  $-55^{\circ}$  C. The engine also features a gear driven water pump, providing better reliability than conventional belt driven technology.

## AXLE AND BRAKES

The 426 rear axle is an enclosed design with a wet multi-plate braking system. The system is oil immersed and self-adjusting, and allows operation in the harshest environments. The rear axle offers 100% Diff-Lock giving increased traction when working on poor ground conditions. This gives increased performance with less wear and tear to tires. The system has dual brake pedals for split braking in confined working spaces. The All Wheel Drive (AWD) is engaged via a front console panel switch or by the brake pedal during all-wheel-braking operation. The AWD can be engaged on the move, under load, in any gear and in forward or reverse. The AWD front axle is pendulum mounted and requires no daily greasing, saving the operator both time and money. An optional guard is available to protect the drive shaft increasing the durability of this machine when working in hard rocky environments.

## TRANSMISSION

The 426 comes equipped with a 40 km/h Power-Shuttle transmission, improving roading speed and providing better spacing between gear ratios. The forward/reverse lever on the steering column is placed for easy directional changes on the move, and the gear selection is from a floor mounted shift lever.







# LOADER PERFORMANCE

PARALLEL LIFT AND SUPERIOR BREAKOUT FORCES.



## PARALLEL LIFT

The 426 parallel lift loader boasts class leading lift capacities and breakout forces, providing more power and excellent productivity. Available with General Purpose Bucket, Multi Purpose Bucket, or Multi Purpose Bucket with Forks, the 426 can be matched precisely to your needs. The parallel lift loader arms make light work of lifting and loading whilst offering excellent forward visibility along with outstanding material retention throughout the lift and lower cycles.

## RIDE CONTROL

Ride control option offers loader suspension to improve ride comfort when moving around the job site or roading the machine. There is also the added benefit of increased material retention providing an invaluable boost in productivity.





# BACKHOE PERFORMANCE

## VERSATILE DESIGN FOR ANY APPLICATION.



### EXCAVATOR STYLE BOOM

Caterpillar's instantly recognizable boom is more than a cosmetic design feature, it also outperforms straight boom designs too. Whether close-up truck loading on a narrow highway or digging over obstacles such as walls, the excavator style boom outperforms the rest. Combine this versatility with powerful breakout forces and the controllability of the load-sensing, flow sharing hydraulic system and you have the best boom and stick combination in the industry. The boom is a narrow design, ensuring maximum visibility to the work tool and ground. Additionally, our system offers swing and boom cushioning as standard. This feature enables very fast trenching by damping the boom on lift. Swing cushioning enables easy spotting of the hoe over the trench to reduce cycle times and boost productivity.



### EXTENDIBLE STICK

The 426 is available with an extendible stick that increases dig depth and reach capability. This allows for greater machine versatility and reduces the amount of time spent repositioning the machine. A sliding inner section design helps to ensure the wear pads remain as dirt free as possible, extending the need for adjustment and replacement intervals. One-Way or Two-Way lines, for operating hydraulic work tools, are available with the E-Stick and have been routed so that they are protected from damage when working in the narrowest of trenches.



# POWERFUL AND EFFICIENT HYDRAULICS

## LOAD-SENSING SYSTEM DELIVERS IMPROVED FUEL ECONOMY.

### HYDRAULIC PERFORMANCE

It's rare that you'll be working at full production 100% of the time, so why should the machine be working at full capacity, using more fuel, making more noise and generally increasing wear and tear on key components? The 426 has a load-sensing, closed center hydraulic system, which is designed to closely match power and flow to the demand needed by the operation. This works to both increase fuel efficiency and decrease wear and tear.

So whether you're in full trenching mode, or delicately digging around services, you are always in total control. In applications such as loading and carrying, speed is important. The system will match the flow needed to get the job done quickly and efficiently. As there is minimal demand on the system unless needed, there are less parasitic horsepower losses and more power available for rimpull which means better loading and roading performance.

The 426 also features flow-sharing hydraulic valves, ensuring that the correct flow of oil reaches the implement cylinders, providing greater control and eliminating oil starvation when operating multiple functions, such as grading with the backhoe bucket.

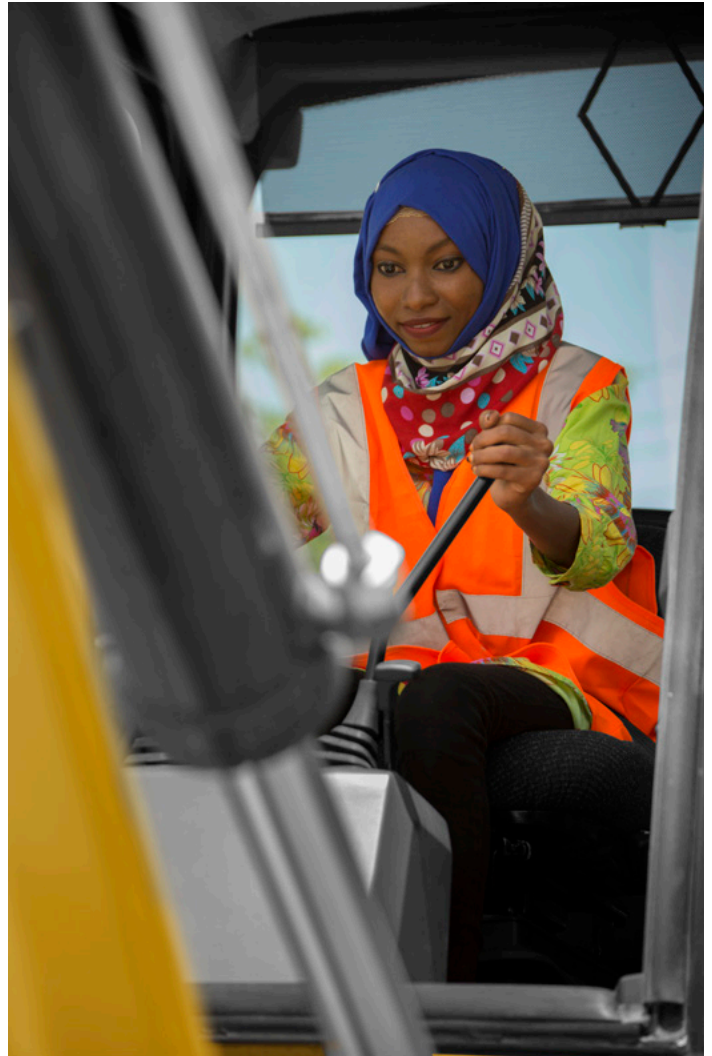











# SERVICEABILITY

## LOOK OUT FOR YOUR PEOPLE AND YOUR EQUIPMENT

### EASY ACCESS

Daily checks that can be time consuming for a busy operator are kept to a minimum on the 426. The 426 is equipped with a flip open hood, allowing access to all the check and fill points, air cleaner, washer bottle and visual check indicators. The 426 offers a clear bowl precleaner, designed especially for the tough environments that this machine operates in giving extra protection to the engine. This is located on top of the hood and gives a visual indicator to the operator that it needs to be emptied, allowing the operator to keep everything clear of debris and the system running cool. The 426 carries on the Cat backhoe loader tradition with sealed for life axle oscillating pins, axle and driveshaft U-joints. Cat Product Link system provides remote reporting of machine location and hours.







# CUSTOMER SUPPORT

## UNRIVALED CUSTOMER SUPPORT NETWORK.

### CUSTOMER VALUE AGREEMENTS

Your Cat dealer can offer a comprehensive range of Customer Value Agreements (CVA) that can be individually tailored to suit your finances and requirements. Dealers can offer a range of options from a full preventive maintenance with Scheduled Oil Sampling (S-O-S<sup>SM</sup>) package to a parts only CVA. Protect your valuable investment and know exactly what your monthly payments will be to help you run your business.

### MACHINE SELECTION

Your dealer can help you with your machine purchase decision, based on your requirements and help keep operating costs to a minimum. Is the machine you have in mind exactly the best for your job or could there be a more suitable solution?

### TRAINING AND SUPPORT

Speak to your dealer about additional support. They can advise you on operating techniques for your machine that will minimize wear and tear, maximize productivity, lower owning and operating costs and help you make the most of the fantastic features offered on the Cat backhoe loader.



### RENOWNED CAT DEALER SUPPORT

From helping you choose the right machine to knowledgeable ongoing support, Cat dealers provide the best in sales and service.

- + Preventive maintenance programs and guaranteed maintenance contracts
- + Best-in-class parts availability
- + Operator training to help boost your profits
- + Genuine Cat Remanufactured parts



# WORK TOOLS

A SOLUTION FOR EVERY JOB.

## LOADER

### LOADER BUCKETS

General Purpose (1.05 m<sup>3</sup>), Multi Purpose (1.0 m<sup>3</sup>) and Multi Purpose with Forks (1.0 m<sup>3</sup>) buckets are all available on the 426 and are all fitted with Bolt-on Teeth.

## BACKHOE

### EXCAVATING BUCKETS

Cat work tools provide a range of buckets in various sizes making it easy to find the correct bucket for your application

- + STANDARD DUTY
- + HEAVY DUTY
- + HIGH CAPACITY
- + ROCK
- + DITCHING

### OTHER AVAILABLE TOOLS FOR BACKHOE

- + COLD PLANERS
- + HAMMERS
- + AUGERS
- + VIBRATORY COMPACTION PLATES

### BACKHOE QUICK COUPLER

A hydraulic loader quick coupler or mechanical hoe quick coupler are available for the 426 making changing of work tools both easy and safe.





# TECHNICAL SPECIFICATIONS

See *cat.com* for complete specifications.

ENGINE		
<b>Model</b>	Cat® 3054C Mechanical Turbocharged (standard)	Cat C4.4 Mechanical Turbocharged Aftercooled (optional)
<b>Rated Power (standard) @ 2,200 rpm</b>		
<b>Gross Power SAE J1995:2014</b>	69.3 kW (93 hp)	70.9 kW (95 hp)
<b>Engine Power ISO 14396:2002</b>	68.5 kW (93 hp)	70 kW (94 hp)
<b>Peak Net Power @ 2,000 rpm</b>		
<b>SAE J1349:2011</b>	66.4 kW (89 hp)	67.2 kW (90 hp)
<b>ISO 9249:2007</b>	65.3 kW (87 hp)	66 kW (88 hp)
<b>Torque Rise (net) @ 1,200 rpm</b>	38%	
<b>Torque Rise (net) @ 1,400 rpm</b>	37%	
<b>Maximum Torque @ 1,400 rpm</b>	394 N·m	383 N·m
<b>Bore</b>	105 mm	105 mm
<b>Stroke</b>	127 mm	127 mm
<b>Displacement</b>	4.4 L	4.4 L
<ul style="list-style-type: none"> <li>• Net power advertised is the power available at the flywheel when the engine is equipped with fan, air cleaner, muffler and alternator.</li> <li>• No derating required up to 2286 m altitude. Auto derate protects hydraulic and transmission systems.</li> <li>• The Cat 3054C engine emits equivalent to U.S. EPA Tier 2/EU Stage II. The optional Cat C4.4 engine emits equivalent to U.S. EPA Tier 3/EU Stage IIIA.</li> </ul>		

HYDRAULIC SYSTEM	
<b>Type</b>	Closed Center
<b>Pump Type</b>	Variable Flow, Axial Piston
<b>Maximum Pump Capacity</b>	132 L/min
<b>System Pressure</b>	
<b>Backhoe</b>	250 Bar
<b>Loader</b>	250 Bar

NOISE LEVEL	
<b>Inside Cab</b>	80 dB(A)
<b>Outside Cab</b>	104 dB(A)

TRANSMISSION	
<b>Travel speeds of Four Wheel Drive backhoe loader at full throttle, when equipped with 16.9×28 rear tires.</b>	
<b>Power Shuttle</b>	
<b>Forward</b>	
<b>1st</b>	5.6 km/h
<b>2nd</b>	9.3 km/h
<b>3rd</b>	21.0 km/h
<b>4th</b>	40.0 km/h
<b>Reverse</b>	
<b>1st</b>	5.6 km/h
<b>2nd</b>	9.3 km/h
<b>3rd</b>	21.0 km/h
<b>4th</b>	40.0 km/h

SERVICE REFILL CAPACITIES	
<b>Cooling System</b>	22.0 L
<b>Fuel Tank</b>	160 L
<b>Engine Oil with Filter</b>	8.8 L
<b>Transmission (Power Shuttle) – AWD</b>	15 L
<b>Rear Axle</b>	16.5 L
<b>Planetaries</b>	1.7 L
<b>Front Axle (AWD)</b>	6.5 L
<b>Planetaries</b>	0.7 L
<b>Hydraulic System</b>	106 L
<b>Hydraulic Tank</b>	40 L

(continued on next page)



# TECHNICAL SPECIFICATIONS

See *cat.com* for complete specifications.

WEIGHTS*	
Operating Weight (estimated)	8425 kg
Operating Weight (Maximum) (ROPS Capacity)	11 000 kg
E-Stick	210 kg
Loader Bucket – GP	530 kg
Loader Bucket – MP	681 kg
Loader Bucket – MP with Fork Brackets	691 kg
<b>Counterweights</b>	
Base	115 kg
Medium	240 kg
High	460 kg
<b>Minimum Counterweight Recommendations – Standard Stick</b>	
GP Loader Bucket	115 kg
MP Loader Bucket	0 kg
<b>Minimum Counterweight Recommendations – E-Stick</b>	
GP Loader Bucket	460 kg
MP Loader Bucket	0 kg
*Machine Configuration – standard engine, standard stick hoe, standard cab with A/C, AWD standard shift transmission, 1 m <sup>3</sup> MP loader bucket, 24 inch standard duty hoe bucket, 12.5/80-18 and 16.9-28 tires, no counterweight, 80 kg operator and full fuel tank.	

AXLES
<b>All Wheel Drive (AWD)</b>
<b>Features</b>
<ul style="list-style-type: none"> <li>• Heavy-duty rear axle with self adjusting inboard brakes and final drives.</li> <li>• AWD is engaged by front console panel switch or by brake pedal during all-wheel-braking operation. AWD can be engaged on the move, under load, in any gear, forward or reverse. AWD has outer final drives for easy maintenance.</li> <li>• AWD front axle is pendulum mounted and permanently sealed and lubricated, requiring no daily maintenance. Also features double-acting steering cylinder with 52° steering angle for increased maneuverability.</li> </ul>

AXLE RATINGS	
<b>Front Axle, AWD</b>	
Static	22 964 kg
Dynamic	9186 kg
<b>Rear Axle</b>	
Static	22 964 kg
Dynamic	9186 kg

STEERING	
Type	Front Wheel
Power Steering	Hydrostatic
<b>AWD Cylinder, One (1) Double-acting</b>	
Bore	65 mm
Stroke	120 mm
Rod Diameter	36 mm
<b>Turning Circle</b>	
AWD (inner wheel not braked)	
Outside Front Wheels	8.18 m
Outside Widest Loader Bucket	10.97 m

BRAKES
<b>Fully enclosed boosted, hydraulic, multiple discs.</b>
<b>Features</b>
<ul style="list-style-type: none"> <li>• Inboard oil-immersed, hydraulically actuated multiple Kevlar discs on final drive input shaft.</li> <li>• Completely enclosed and sealed.</li> <li>• Self-adjusting.</li> <li>• Dual foot-operated boosted brake pedals can be interlocked for roading.</li> <li>• Parking brakes are independent of the service brake system. The parking brake is mechanically applied through a hand lever located in the right side console.</li> <li>• Meets ISO 3450:2011 and CMVR requirements.</li> </ul>



# TECHNICAL SPECIFICATIONS

See *cat.com* for complete specifications.

## MACHINE DIMENSIONS

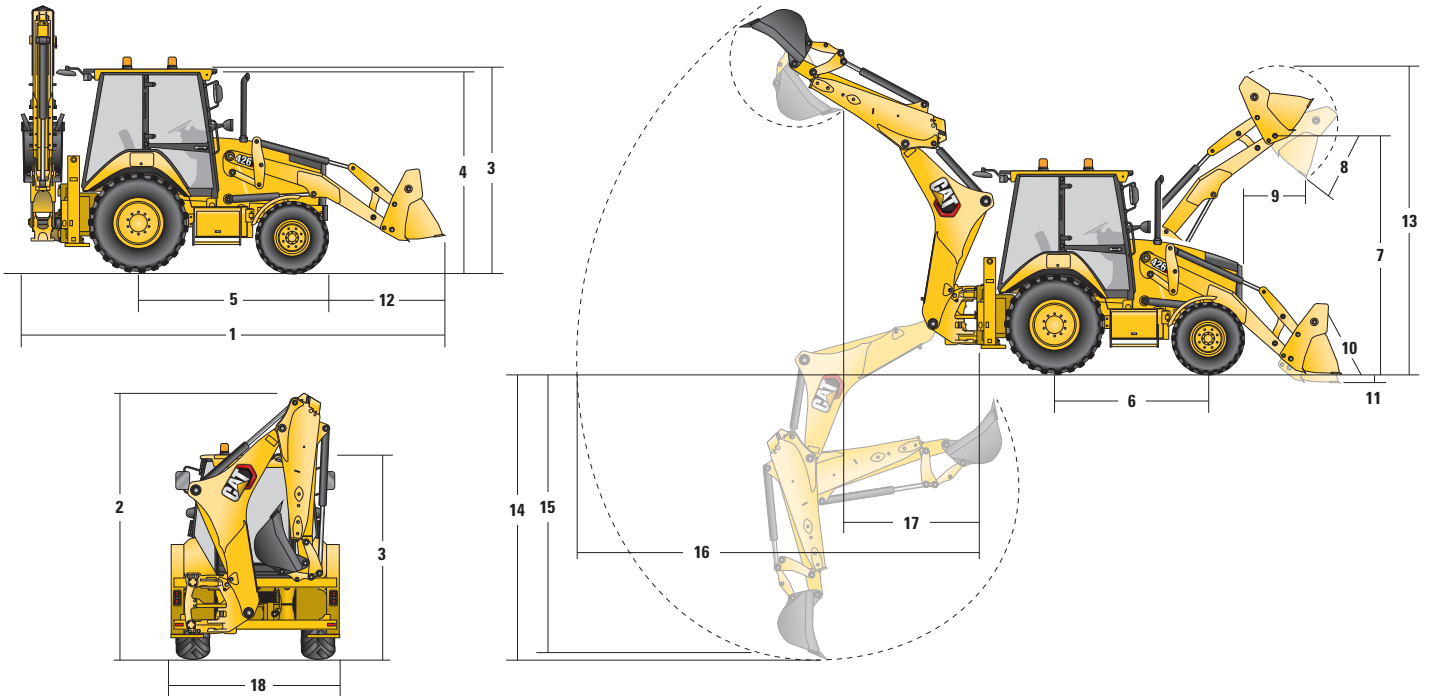

	426		
	GP – 1.05 m <sup>3</sup>	MP – 1 m <sup>3</sup>	MP with Forks – 1 m <sup>3</sup>
1 Overall Length in Rooding Position	5725 mm	5674 mm	5674 mm
Overall Transportation Length	5677 mm	5681 mm	5681 mm
2 Overall Transportation Height	3757 mm	3757 mm	3757 mm
Overall Width	2346 mm	2346 mm	2346 mm
3 Height to Top of Cab/Canopy	2895 mm	2895 mm	2895 mm
4 Height to Top of Exhaust Stack	2716 mm	2716 mm	2716 mm
5 Rear Axle Centerline to Front Grill	2708 mm	2708 mm	2708 mm
6 Wheelbase AWD	2200 mm	2200 mm	2200 mm

Dimensions and performance specifications shown are for machines equipped with 12.5/80-18 front tires, 16.9-28 rear tires, standard cab, standard stick with 610 mm standard duty bucket, and standard equipment unless otherwise specified.



# TECHNICAL SPECIFICATIONS

See *cat.com* for complete specifications.

LOADER BUCKET DIMENSIONS AND PERFORMANCE			
	GP – 1.05 m <sup>3</sup>	MP – 1 m <sup>3</sup>	MP with Forks – 1 m <sup>3</sup>
Capacity	1.05 m <sup>3</sup>	1 m <sup>3</sup>	1 m <sup>3</sup>
Width	2262 mm	2262 mm	2262 mm
Lift Capacity at Maximum Height	3630 kg	3496 kg	3172 kg
Lift Breakout Force	54.48 kN	53.95 kN	51.04 kN
Tilt Breakout Force	53.91 kN	60.47 kN	59.26 kN
Tipping Load at Breakout Point	6225 kg	6301 kg	6048 kg
7 Maximum Hinge Pin Height	3449 mm	3449 mm	3449 mm
8 Dump Angle at Full Height	46°	46°	46°
Dump Height at Maximum Angle	2735 mm	2766 mm	2766 mm
9 Dump Reach at Maximum Angle	897 mm	822 mm	822 mm
10 Maximum Bucket Rollback at Ground Level	41°	42°	40°
11 Digging Depth	112 mm	145 mm	145 mm
Maximum Grading Angle	113°	116°	116°
12 Grill to Bucket Cutting Edge, Carry Position	1480 mm	1449 mm	1449 mm
13 Maximum Operating Height	4370 mm	4348 mm	4832 mm

EXCAVATOR BUCKET DIMENSIONS AND PERFORMANCE			
	Standard Stick	E-Stick Retracted	E-Stick Extended
14 Digging Depth, SAE Maximum	4116 mm	4191 mm	5208 mm
Digging Depth, Manufacturer's Maximum	4707 mm	4756 mm	5697 mm
15 Digging Depth, 2440 mm Flat Bottom	3740 mm	3806 mm	4887 mm
Digging Depth, 600 mm Flat Bottom	4092 mm	4158 mm	5168 mm
Digging Depth, 600 mm Flat Bottom, Manufacturer's	4668 mm	4719 mm	5684 mm
16 Reach from Swing Pivot at Ground Line	5603 mm	5657 mm	6585 mm
Maximum Operating Height	5721 mm	5722 mm	6338 mm
Loading Height	3934 mm	3947 mm	4491 mm
17 Loading Reach	1528 mm	1648 mm	2546 mm
Swing Arc	180°	180°	180°
Bucket Rotation	205°	205°	205°
18 Stabilizer Overall Width	2242 mm	2242 mm	2242 mm
Bucket Dig Force	57.22 kN	56.61 kN	56.61 kN
Stick Dig Force	35.3 kN	33.66 kN	24.59 kN



# STANDARD & OPTIONAL EQUIPMENT

Standard and optional equipment may vary. Consult your Cat dealer for details.

CAB	STANDARD	OPTIONAL
Canopy, Base	•	
Canopy, Plus		•
Cab, Standard		•
Cab, Standard Plus		•
*See Cab Options Page		
Cab ROPS (Roll Over Protective Structure) and FOPS (Falling Objects Protective Structure) are standard. ROPS offered by Caterpillar for this machine meets ROPS criteria ISO 3471:2008 and FOPS II criteria ISO 3449:2005		
TIRES/STEERING/BRAKES	STANDARD	OPTIONAL
Two Wheel Drive	•	
All Wheel Drive		•
Hydraulic Boosted Brakes (dual pedals)	•	
Tires 12-16.5 (Front) – 2WD	•	
Tires 12.5/80-18 (Front) – AWD	•	
Tires 16.9-28 Rear	•	
Tires 18.4-26 Rear		•
ENGINE/TRANSMISSION	STANDARD	OPTIONAL
Battery 750 CCA, Maintenance Free (standard)	•	
Battery 750 CCA, Maintenance Free (heavy duty)		•
Engine 68.5 kW (93 hp) Cat 3054C	•	
Engine 70 kW (94 hp) Cat C4.4		•
Engine Block Heater		•
Transmission Neutralizer	•	
Transmission, 4 Speed Manual	•	
INPUT	STANDARD	OPTIONAL
Controls, Mechanical Lever	•	
Power Steering, Hydrostatic	•	
OTHER ATTACHMENTS	STANDARD	OPTIONAL
Counterweight, 115 kg		•
Counterweight, 240 kg		•
Counterweight, 460 kg		•
Front Fenders		•
Street Pads, Stabilizers		•
Tool Storage Box	•	
Transport Tie – Downs	•	
Rear License Plate Holder and Light		•

GUARDS	STANDARD	OPTIONAL
Guard, Driveshaft		•
Guard, Tail Lights		•
Loader Safety Brace	•	
BOOM STICKS AND LINKAGES – BACKHOE	STANDARD	OPTIONAL
Quick Coupler, Mechanical (backhoe)		•
Stick Standard	•	
Stick Extending		•
Transport Lock, Swing	•	
Transport Lock, Boom	•	
HYDRAULICS	STANDARD	OPTIONAL
Hydraulic Pump (132 L/min)	•	
Hydraulic Auxiliary Quick Disconnects		•
Side Shift Lock (electro-hydraulic)	•	
Hydraulic Oil Cooler	•	
HYDRAULICS – BACKHOE	STANDARD	OPTIONAL
Hydraulic Lines, 1-Way		•
Hydraulic Lines, 2-Way (with E-Stick)		•
HYDRAULICS – LOADER	STANDARD	OPTIONAL
Loader Kickout, Float	•	
Ride Control		•
Parallel Lift	•	
ELECTRICAL	STANDARD	OPTIONAL
Product Link, Cellular	•	
Reversing Alarm	•	
Beacon, Strobe		•
Beacon, Standard		•
12 Volt Electrical System	•	
120 Ampere Alternator	•	

**Not all features are available in all regions. Please check with your local Cat dealer for specific offering availability in your area.**

For additional information, refer to the Technical Specifications brochure available at [www.cat.com](http://www.cat.com) or your Cat dealer.

# CAB OPTIONS

CAB OPTIONS				
	Canopy, Base	Canopy, Plus	Cab, Standard	Cab, Standard Plus
Air Conditioning			Optional	Optional
Arm Rests				✓
Beacon Socket (x2)	✓	✓	✓	✓
Cup Holder	✓	✓	✓	✓
Differential Lock Button on Loader Control	✓	✓	✓	✓
Face Fan	Optional	Optional	Optional	Optional
Removable floor mat	✓	✓	✓	✓
Front and Rear Side Opening Windows			✓	✓
Front Headlights	✓	✓	✓	✓
Full Width Perforated Sun Visor			Optional	Optional
Fully Adjustable Halogen Work Lights (x6)	✓	✓	✓	✓
Cab, Fully Glazed			✓	✓
Cab, Part Glazed (front window)		✓		
Gauge Cluster	✓	✓	✓	✓
Horn, Front	✓	✓	✓	✓
Horn, Rear	✓	✓	✓	✓
Internal Power Socket (x2)	✓	✓	✓	✓
Rear Tail Lights	✓	✓	✓	✓
Left and Right opening Doors			✓	✓
Left Hand Storage Console	✓	✓	✓	✓
Safety Lock, Transmission	✓	✓	✓	✓
Seat, Vinyl with Mechanical Suspension	✓	✓		
Seat, Fabric with Mechanical Suspension			✓	✓
Self-Cancelling Directional Indicator	✓	✓	✓	✓
Steering Wheel Column, Tilt Adjustment				✓
Window Wash Wipers, Rear			✓	✓
Window Wash Wipers, Front		✓	✓	✓



For more complete information on Cat products, dealer services and industry solutions, visit us on the web at [www.cat.com](http://www.cat.com)

© 2023 Caterpillar. All Rights Reserved.

Materials and specifications are subject to change without notice. Featured machines in photos may include additional equipment. See your Cat dealer for available options.

CAT, CATERPILLAR, LET'S DO THE WORK, their respective logos, "Caterpillar Corporate Yellow," the "Power Edge" and Cat "Modern Hex" trade dress as well as corporate and product identity used herein, are trademarks of Caterpillar and may not be used without permission.

[www.cat.com](http://www.cat.com) [www.caterpillar.com](http://www.caterpillar.com)

AEHQ8414-02 (11-2023)  
Replaces AEHQ8414 -01  
(Africa/Middle East, Eurasia, APD,  
South America excluding Brazil)

