

# Cat® DG100

## Gas Generator Sets

### North America



Image shown may not reflect actual configuration.

Engine Model	6.2L V8 TCAC
No. of Cylinders	8
Bore x Stroke	101.6 mm x 95.3 mm
Displacement	6.2 Liter
Compression Ratio	9.8:1
Aspiration	Turbocharged & Aftercooled
Fuel System	Electronic Regulator / Spark Ignition
Governor	G2 Class* capable – Electronic

### For North America, 60 Hz Market

Model	Emergency Standby		Emissions Strategy
	Natural Gas ekW	Propane ekW	
DG100	100	89*	U.S. EPA Certified for Stationary Emergency Application

### PACKAGE PERFORMANCE

Performance	Emergency Standby	
	Natural Gas	Propane
Frequency	60 Hz	
Genset power rating, ekW (3-Phase / 1-Phase)	100 / 100	89 / 86
Performance Numbers (3-Phase / 1-Phase)	EM6752 / EM6934	EM6753 / EM6935
<b>Fuel System / Fuel Consumption</b>		
Minimum Running pressure to Electronic Pressure Regulator (EPR), psi (in. water)	0.25 (7)	0.25 (7)
Maximum Running pressure to Electronic Pressure Regulator (EPR), psi (in. water)	0.40 (11)	0.40 (11)
100% load with fan, kg/hr (ft <sup>3</sup> /hr)	27.7 (1255)	25.8 (482)
75% load with fan, kg/hr (ft <sup>3</sup> /hr)	21.9 (989)	20.2 (378)
50% load with fan, kg/hr (ft <sup>3</sup> /hr)	15.5 (701)	14.3 (268)
<b>Cooling System<sup>1</sup></b>		
Radiator air flow, m <sup>3</sup> /min (cfm)	322 (11371)	322 (11371)
Radiator air flow restriction (system), kPa (in. water)	0.12	0.12
Engine coolant capacity, L (gal)	14.5 (3.8)	14.5 (3.8)
Radiator coolant capacity, L (gal)	7.6 (2.0)	7.6 (2.0)
Total coolant capacity, L (gal)	22.1 (5.8)	22.1 (5.8)
<b>Inlet Air</b>		
Combustion air inlet flow rate, m <sup>3</sup> /min (cfm) (kg/hr)	6.2 (219) (457.7)	5.1 (178.7) (372)
Maximum allowable intake air restriction, kPa (in. water)	3.48 (13.98)	
<b>Exhaust System</b>		
Exhaust stack gas temperature, °C (°F)	630 (1166)	619 (1146)
Exhaust gas flow rate, m <sup>3</sup> /min (cfm) (kg/hr)	24.5 (846.1) (486)	19.5 (688.6) (396)
Exhaust system back pressure kPa (in. water)	15 (60.28)	
<b>Heat Rejection</b>		
Heat rejection to jacket water, ekW (Btu/min)	74 (4208)	61 (3469)
Heat rejection to after cooler, ekW (Btu/min)	11 (625)	8 (455)
Heat rejection to oil cooler, ekW (Btu/min)	11 (625)	8 (455)
Heat rejection to atmosphere from engine, ekW (Btu/min)	52 (2957)	37 (2104)
Heat rejection to exhaust (Total), ekW (Btu/min)	117 (6653)	96 (5459)

Performance	Emergency Standby	
	Natural Gas	Propane
<b>Lube System</b>		
Sump refill with filter, L (gal)	5.4 (1.43)	5.4 (1.43)
Maximum oil temperature, °C (°F)	121 (250)	121 (250)
Maximum oil capacity, L (gal)	7.6 (2)	7.6 (2)
Minimum oil capacity, L (gal)	4.7 (1.24)	4.7 (1.24)
<b>Emissions (Nominal)</b>		
NOx, mg/Nm <sup>3</sup> (g/hp-hr)	0.26 (0.19)	0.23 (0.17)
CO, mg/Nm <sup>3</sup> (g/hp-hr)	0.13 (0.09)	2.1 (1.59)

## ALTERNATOR DATA

DG100								
Alternator	60 Hz 3-Phase							60 Hz 1-Phase
	Voltages	480/277	380/220	240/120	240/139	220/127	208/120	600/346
Motor starting capability @ 30% Voltage Dip, skVA	336	225	263	336	290	264	349	229
Current, Amps - Natural Gas / Propane	150 / 134	190/166	301 / 268	301 / 267	328/ 286	347 / 309	120 / 107	417 / 358
Temperature rise, °C	105	105	105	105	105	105	105	105
Frame size	M2254L4	M2254L4	M2254L4	M2254L4	M2254L4	M2254L4	M2254L4	M2238L4
Excitation	PMG	PMG	PMG	PMG	PMG	PMG	PMG	SE

Motor starting capability is based on the assumption of 0.6 pf.  
 Temperature rise and Current in amps are based on the Standby rating at the respective voltages

**WEIGHTS & DIMENSIONS**

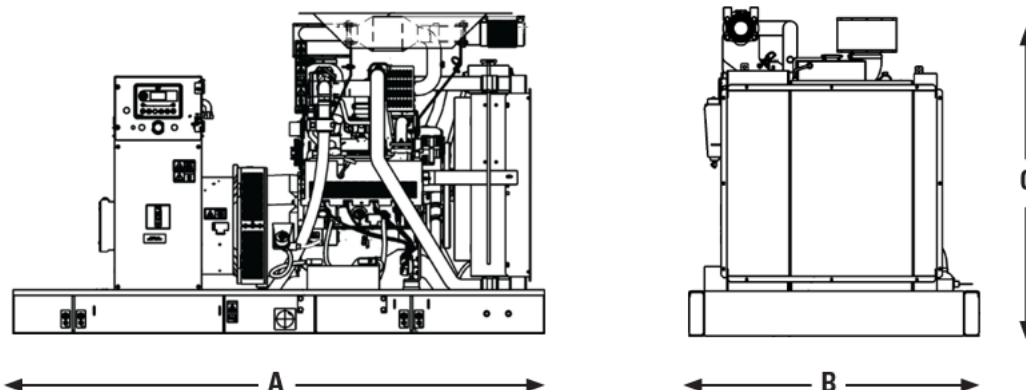

Length "A" mm (in)	Width "B" mm (in)	Height "C" mm (in)	Dry Weight Kg (lb)
2442 (96)*	1297 (51)*	1449 (57)*	1364 (3007)*

**Note:** General configuration not to be used for installation. See general dimension drawings for detail.

**APPLICABLE CODES AND STANDARDS:**

CSA C22.2 No 100-04, UL 489, UL 869, UL 2200, NFPA 37, NFPA 70, NFPA 99, NFPA 110, IBC, IEC60034-1, ISO 3046, ISO 8528, NEMA MG 1-22, NEMA MG 1-33.

**EMERGENCY STANDBY POWER (ESP):** Output available with varying load for the duration of the interruption of the normal source power. Average power output is 70% of the standby rated kW. Typical operation is 50 hours per year, with maximum expected usage of 200 hours per year.

**Ratings** are based on SAE J1349 standard conditions. These ratings also apply at ISO 3046 standard conditions.

**1 CFH = 1000 BTU/HR**

Fuel Rates are based on heat values of 1015 BTU/SCF for Natural Gas and 2500 BTU/SFC for Propane Vapor @77°F (25°C) and 328 ft (100m) above sea level.

**DEFINITIONS AND CONDITIONS**

<sup>1</sup> For ambient and altitude capabilities consult your Cat dealer. Air flow restriction (system) is added to the existing restriction from the factory.

<sup>2</sup> Generator temperature rise is based on a 40°C (104°F) ambient per NEMA MG1-32.

# Operating Fuel Pressure is the fuel pressure required to be delivered at the genset base frame rail connection.

**LET'S DO THE WORK.™**

[www.cat.com/electricpower](http://www.cat.com/electricpower)

©2024 Caterpillar  
 All rights reserved.

Materials and specifications are subject to change without notice.

The International System of Units (SI) is used in this publication. CAT, CATERPILLAR, LET'S DO THE WORK, their respective logos, "Caterpillar Corporate Yellow", the "Power Edge" and Cat "Modern Hex" trade dress as well as corporate and product identity used herein, are trademarks of Caterpillar and may not be used without permission.

# Cat® DG100

## Gas Generator Sets

### Latin America



Image shown may not reflect actual configuration.

Engine Model	6.2L V8 TCAC
No. of Cylinders	8
Bore x Stroke	101.6 mm x 95.3 mm
Displacement	6.2 Liter
Compression Ratio	9.8:1
Aspiration	Turbocharged & Aftercooled
Fuel System	Electronic Regulator / Spark Ignition
Governor	G2 Class* capable – Electronic

### For Latin America, 60 Hz Market

Model	Emergency Standby		Emissions Strategy
	Natural Gas ekW	Propane ekW	
DG100	100	89*	U.S. EPA Certified for Stationary Emergency Application

### PACKAGE PERFORMANCE

Performance	Emergency Standby	
	Natural Gas	Propane
Frequency	60 Hz	
Genset power rating, ekW (3-Phase / 1-Phase)	100 / 100	89 / 86
Performance Numbers (3-Phase / 1-Phase)	EM6752 / EM6934	EM6753 / EM6935
<b>Fuel System / Fuel Consumption</b>		
Minimum Running pressure to Electronic Pressure Regulator (EPR), psi (in. water)	0.25 (7)	0.25 (7)
Maximum Running pressure to Electronic Pressure Regulator (EPR), psi (in. water)	0.40 (11)	0.40 (11)
100% load with fan, kg/hr (ft <sup>3</sup> /hr)	27.7 (1255)	25.8 (482)
75% load with fan, kg/hr (ft <sup>3</sup> /hr)	21.9 (989)	20.2 (378)
50% load with fan, kg/hr (ft <sup>3</sup> /hr)	15.5 (701)	14.3 (268)
<b>Cooling System<sup>1</sup></b>		
Radiator air flow, m <sup>3</sup> /min (cfm)	322 (11371)	322 (11371)
Radiator air flow restriction (system), kPa (in. water)	0.12	0.12
Engine coolant capacity, L (gal)	14.5 (3.8)	14.5 (3.8)
Radiator coolant capacity, L (gal)	7.6 (2.0)	7.6 (2.0)
Total coolant capacity, L (gal)	22.1 (5.8)	22.1 (5.8)
<b>Inlet Air</b>		
Combustion air inlet flow rate, m <sup>3</sup> /min (cfm) (kg/hr)	6.2 (219) (457.7)	5.1 (178.7) (372)
Maximum allowable intake air restriction, kPa (in. water)	3.48 (13.98)	
<b>Exhaust System</b>		
Exhaust stack gas temperature, °C (°F)	630 (1166)	619 (1146)
Exhaust gas flow rate, m <sup>3</sup> /min (cfm) (kg/hr)	24.5 (846.1) (486)	19.5 (688.6) (396)
Exhaust system back pressure kPa (in. water)	15 (60.28)	
<b>Heat Rejection</b>		
Heat rejection to jacket water, ekW (Btu/min)	74 (4208)	61 (3469)
Heat rejection to after cooler, ekW (Btu/min)	11 (625)	8 (455)
Heat rejection to oil cooler, ekW (Btu/min)	11 (625)	8 (455)
Heat rejection to atmosphere from engine, ekW (Btu/min)	52 (2957)	37 (2104)
Heat rejection to exhaust (Total), ekW (Btu/min)	117 (6653)	96 (5459)

Performance	Emergency Standby	
	Natural Gas	Propane
<b>Lube System</b>		
Sump refill with filter, L (gal)	5.4 (1.43)	5.4 (1.43)
Maximum oil temperature, °C (°F)	121 (250)	121 (250)
Maximum oil capacity, L (gal)	7.6 (2)	7.6 (2)
Minimum oil capacity, L (gal)	4.7 (1.24)	4.7 (1.24)
<b>Emissions (Nominal)</b>		
NOx, mg/Nm <sup>3</sup> (g/hp-hr)	0.26 (0.19)	0.23 (0.17)
CO, mg/Nm <sup>3</sup> (g/hp-hr)	0.13 (0.09)	2.1 (1.59)

## ALTERNATOR DATA

DG100								
Alternator	60 Hz 3-Phase							60 Hz 1-Phase
Voltages	480/277	380/220	240/120	240/139	220/127	208/120	600/346	240/120
Motor starting capability @ 30% Voltage Dip, skVA	336	225	263	336	290	264	349	229
Current, Amps - Natural Gas / Propane	150 / 134	190/166	301 / 268	301 / 267	328/ 286	347 / 309	120 / 107	417 / 358
Temperature rise, °C	105	105	105	105	105	105	105	105
Frame size	M2254L4	M2254L4	M2254L4	M2254L4	M2254L4	M2254L4	M2254L4	M2238L4
Excitation	PMG	PMG	PMG	PMG	PMG	PMG	PMG	SE

Motor starting capability is based on the assumption of 0.6 pf.  
 Temperature rise and Current in amps are based on the Standby rating at the respective voltages

**WEIGHTS & DIMENSIONS**

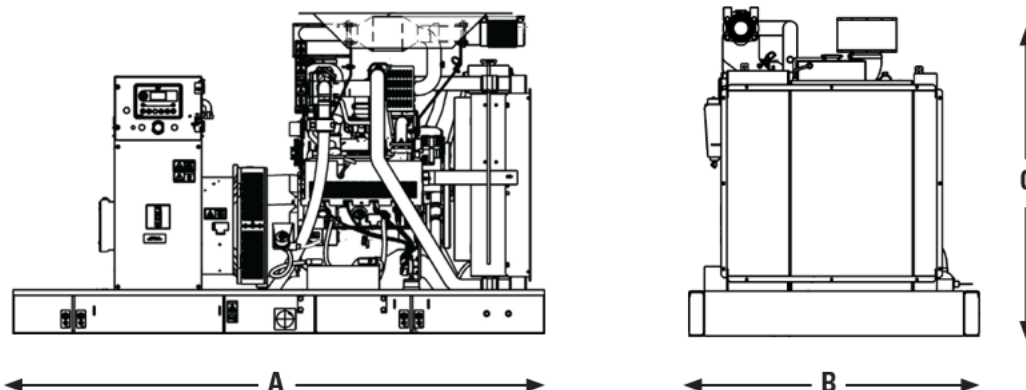

Length "A" mm (in)	Width "B" mm (in)	Height "C" mm (in)	Dry Weight Kg (lb)
2442 (96)*	1297 (51)*	1449 (57)*	1364 (3007)*

**Note:** General configuration not to be used for installation. See general dimension drawings for detail.

**APPLICABLE CODES AND STANDARDS:**

CSA C22.2 No 100-04, UL 489, UL 869, UL 2200, NFPA 37, NFPA 70, NFPA 99, NFPA 110, IBC, IEC60034-1, ISO 3046, ISO 8528, NEMA MG 1-22, NEMA MG 1-33.

**EMERGENCY STANDBY POWER (ESP):** Output available with varying load for the duration of the interruption of the normal source power. Average power output is 70% of the standby rated kW. Typical operation is 50 hours per year, with maximum expected usage of 200 hours per year.

**Ratings** are based on SAE J1349 standard conditions. These ratings also apply at ISO 3046 standard conditions.

**1 CFH = 1000 BTU/HR**

Fuel Rates are based on heat values of 1015 BTU/SCF for Natural Gas and 2500 BTU/SFC for Propane Vapor @77°F (25°C) and 328 ft (100m) above sea level.

**DEFINITIONS AND CONDITIONS**

<sup>1</sup> For ambient and altitude capabilities consult your Cat dealer. Air flow restriction (system) is added to the existing restriction from the factory.

<sup>2</sup> Generator temperature rise is based on a 40°C (104°F) ambient per NEMA MG1-32.

# Operating Fuel Pressure is the fuel pressure required to be delivered at the genset base frame rail connection.

**LET'S DO THE WORK.™**

[www.cat.com/electricpower](http://www.cat.com/electricpower)

©2024 Caterpillar  
 All rights reserved.

Materials and specifications are subject to change without notice.

The International System of Units (SI) is used in this publication. CAT, CATERPILLAR, LET'S DO THE WORK, their respective logos, "Caterpillar Corporate Yellow", the "Power Edge" and Cat "Modern Hex" trade dress as well as corporate and product identity used herein, are trademarks of Caterpillar and may not be used without permission.