



Cat[®] CS78B

SMOOTH DRUM VIBRATORY SOIL COMPACTOR

FEATURES:

The Cat[®] CS78B features a smooth drum and is ideally suited for granular soil applications or cohesive soil applications with the use of an optional padfoot shell kit:

- **Comfortable and ergonomic operator station** features pivoting seat with integrated multifunction LCD display and control console, outstanding visibility to the front and rear of machine, low sound levels and vibration for greater operator comfort and productivity.
- **World-class propel system** built around the exclusive Cat dual pump propel system, two pumps provide separate dedicated flow to drum drive motor and rear axle motor for exceptional gradeability and traction in forward and reverse. New electronic propel control provides more precise machine control.
- **Virtually maintenance free** due to maintenance-free hitch bearings and extended maintenance intervals for vibratory system and hydraulic system, providing more uptime and lower maintenance costs.
- **Enhanced compaction performance** due to more weight at the drum and greater amplitude. Automated speed control and vibratory system functions make it easy to ensure consistent, high quality compaction.
- **Optional Cat Compaction Control** helps the operator determine when compaction has been completed to specification for greater productivity and uniform compaction quality. CMV or exclusive Machine Drive Power (MDP) measurement technology available.

Specifications

Engine - Power Train

Engine Model	Cat C7.1	
Global Emissions	US EPA Tier 3/EU Stage IIIA	
Gross Power ISO 14396	129 kW	173 hp
Displacement	7.01 L	428 in ³
Stroke	135 mm	5.3 in
Bore	105 mm	4.1 in
Max. Travel Speed (Forward or Reverse)	11.4 km/h	7 mph
Theoretical Gradeability, no vibration*	53%	

Weights

Operating Weight w/ open platform	18 175 kg	40,069 lb
Operating Weight w/ steel sun canopy	18 270 kg	40,279 lb
Operating Weight w/ ROPS/FOPS canopy	18 445 kg	40,664 lb
w/ oval padfoot shell kit	18 826 kg	41,504 lb
w/ square padfoot shell kit	18 981 kg	41,846 lb
Operating Weight w/ ROPS/FOPS cab	18 760 kg	41,359 lb
w/ oval padfoot shell kit	19 141 kg	42,197 lb
w/ square padfoot shell kit	19 296 kg	42,540 lb
Weight at Drum w/ open platform	13 230 kg	29,167 lb
Weight at Drum w/ steel sun canopy	13 260 kg	29,233 lb
Weight at Drum w/ ROPS/FOPS canopy	13 315 kg	29,355 lb
Weight at Drum w/ ROPS/FOPS cab	13 450 kg	29,652 lb

Padfoot shell kit includes shell and replacement bumper. Shell kits are available with all configurations, not just those shown.

** Actual gradeability may vary based on site conditions and machine configuration. Refer to the Operation and Maintenance Manual for more information.*

Vibratory System Specifications

Frequency		
Standard	28 Hz	1680 vpm
During Eco-mode Operation	25.5 Hz	1527 vpm
Optional Variable Frequency	23.3-28 Hz	1400-1680 vpm
Nominal Amplitude @ 28 Hz (1680 vpm)		
High	2.1 mm	0.083 in
Low	0.98 mm	0.039 in
Centrifugal Force @ 28 Hz (1680 vpm)		
Maximum	332 kN	74,600 lb
Minimum	166 kN	37,300 lb
Static Linear Load		
w/ open platform	62 kg/cm	347.2 lbs/in
w/ steel sun canopy	62.1 kg/cm	348 lbs/in
w/ ROPS/FOPS canopy	62.4 kg/cm	349.5 lbs/in
w/ ROPS/FOPS cab	63 kg/cm	353 lbs/in

Service Refill Capacities

Fuel Tank, total capacity	332 L	88 gal
Cooling System	28.2 L	7.5 gal
Engine Oil w/ Filter	17.4 L	4.6 gal
Eccentric Weight Housings	26 L	6.9 gal
Axle and Final Drives	24 L	6.3 gal
Hydraulic Tank (service refill)	50 L	13.2 gal



CS78B Vibratory Soil Compactor

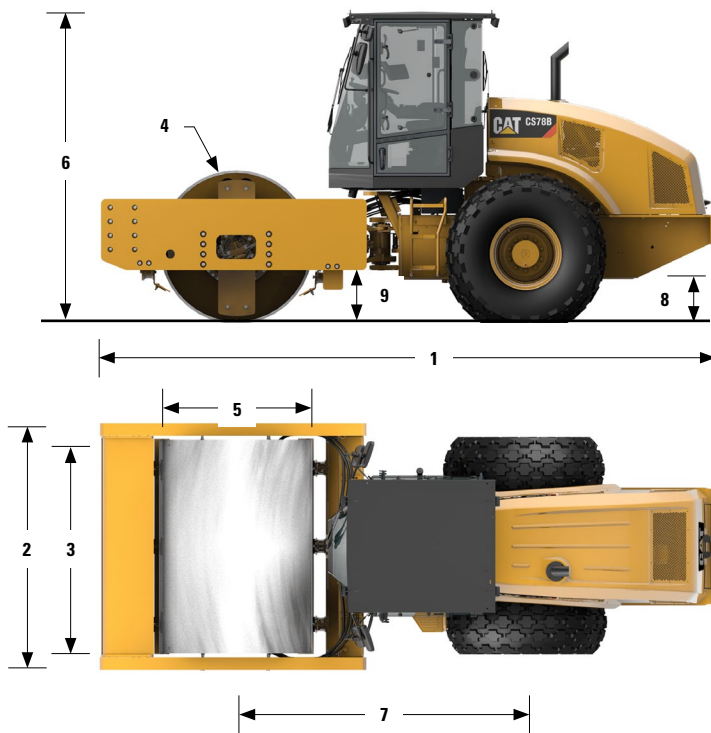

Dimensions

1 Overall Length	6.13 m	20.1 ft
2 Overall width	2.46 m	8.08 ft
3 Drum Width	2134 mm	84 in
4 Drum Shell Thickness	40 mm	1.6 in
5 Drum Diameter	1534 mm	60.4 in
6 Maximum Overall Height	3.11 m	10.2 ft
7 Wheelbase	2.9 m	9.5 ft
8 Ground Clearance	437 mm	17.2 in
9 Curb Clearance	535 mm	21.1 in
Inside Turning Radius	3.68 m	12.07 ft
Hitch Articulation Angle	34°	
Hitch Oscillation Angle	15°	

STANDARD EQUIPMENT *Varies by market- contact your dealer for specifics.*

ELECTRICAL

- 24 volt Electrical System
- 100 ampere Alternator
- 750 Cold-cranking Amps Battery Capacity

OPERATOR ENVIRONMENT

- Open Platform with Handrails/Guardrails, Floor Mat
- Vinyl Adjustable Pivoting Seat with Integrated Console and LCD Display
- Multifunction LCD Display with gauges and audible warning for: *Hydraulic oil temperature, Engine oil pressure, Engine coolant temperature, Alternator charge, Fuel level, Service hour meter, Engine RPM, Ground speed, Vibe frequency, Fuel rate, Air filter constriction, Engine load and Optional Cat Compaction Control*
- Adjustable Tilting Steering Column with Integrated Cup Holders
- Seat Belt
- 12-volt Power Outlet
- Interior Rear View Mirror
- Horn, Backup Alarm

POWER TRAIN

- Cat C7.1 Diesel Engine
- Air Cleaner, Dual Element
- Three-speed Throttle Switch, Eco-mode and Automatic Speed Control
- Dual Propel Pumps; One for Drum Drive, One for Rear Axle
- Fuel Filter, Water Separator, Priming Pump, Water Indicator
- Tilting Radiator/Hydraulic Oil Cooler
- Dual Braking System
- Two-speed Hydrostatic Transmission

VIBRATORY SYSTEM

- Smooth Drum
- Dual Amplitude, Single Frequency
- Dual Pod-Style Eccentric Weight Housings
- Auto-vibe Function
- Front Adjustable Steel Scrapers

OTHER

- Sight Gauges for Hydraulic Oil Level and Radiator Coolant Level
- S-O-SSM Sampling Valves: Engine Oil, Hydraulic Oil and Coolant

OPTIONAL EQUIPMENT

- Steel Sun Canopy
- ROPS/FOPS Canopy
- ROPS/FOPS Cab with Climate Control
- Padfoot Shell Kit (oval or square pads available- includes bumper)
- Variable Vibration Frequency
- Beacon, Rotating
- Polyurethane Drum Scrapers
- Steel Rear-side Drum Scraper
- Sun Visor
- Deluxe High-back Air-ride Pivoting Seat (with Cab only)
- Cat Compaction Control, Machine Drive Power or CMV
- SBAS GNSS Mapping for Cat Compaction Control (RTK available)
- Upgraded Halogen Light Package
- Cab Internal Rear View Mirrors
- Cab Internal Roll-down Sun Screen
- Product Link™
- Additional Rear View Mirrors
- Fuel Fill Access Door
- Transmission Guard

For more complete information on Cat products, dealer services, and industry solutions, visit us on the web at www.cat.com

QEHO2357 (12-17)

© 2017 Caterpillar
All Rights Reserved
Printed in U.S.A.

LRC

Materials and specifications are subject to change without notice. Featured machines in photos may include additional equipment. See your Cat dealer for available options.

CAT, CATERPILLAR, BUILT FOR IT, their respective logos, "Caterpillar Yellow" and the "Power Edge" trade dress, as well as corporate and product identity used herein, are trademarks of Caterpillar and may not be used without permission.

