

C280-12 Marine Propulsion Engine

Electronic Control System

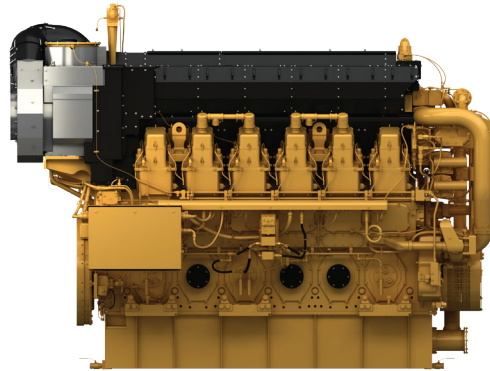
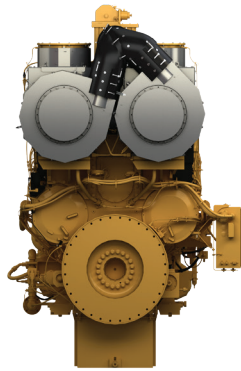

ENGINE SPECIFICATIONS

CONFIGURATION	VEE 12, 4-Stroke Cycle diesel	BORE x STROKE	280 mm x 300 mm / 11.0 in x 11.8 in
EMISSIONS	IMO II U.S. EPA Tier 4, IMO III (Cat SCR required)	REFILL CAPACITY LUBE OIL SYSTEM W/ OIL FILTER CHANGE	1211 L (320 gal)
RATED ENGINE SPEED	900 / 1,000 rpm	OIL CHANGE INTERVAL	1,000 hrs
DISPLACEMENT	222 L (13, 456 cu in)	ROTATION (from flywheel end)	Clockwise or counterclockwise
ASPIRATION	Twin Turbocharged - aftercooled	COOLING	Separate circuit or combined circuit
GOVERNOR	Electronic (A4 ECM)		

KEY FEATURES & BENEFITS

- Advanced combustion design uses the optimum configurations and cylinder geometry for low visible smoke
- Market leading power to weight ratio
- Improved part load/part speed performance
- Electronic governing control unit minimizes fuel consumption and monitors engine operating parameter
- Optimal nozzle geometry and electronic injection control for improved fuel delivery
- Improved torque rise capability
- Cold mode start strategy and programmable low idle
- Ease of serviceability and maintenance
- Durable core engine design with over 100 million operating hours and thousands of engines sold
- Global dealer network for unparalleled support

STANDARD EQUIPMENT

- SOLAS Compliant hard heat shield system
- Gear driven coolant and oil pumps
- 50 degree vee engine block for reduced width
- Dual A4 ECM with rigid wiring harness
- 1.5% speed margin for waterjet specification
- EUI fuel system
- Duplex fuel and oil filters
- Centrifugal oil filters
- Explosion relief valves
- Air driven pre/post-lube pump
- Air starters
- Six point engine mounting feet

OPTIONAL ATTACHMENTS

- Opposite end drive capability
- LECP II/III Panels and CMD 5/8/13 displays
- Marine alarm and protection system
- MCS Certification
- Full power stubshaft
- Air shutoff device
- Mechanical load sharing
- Cold weather boost control valve
- Auxiliary water pump
- RH/LH service options
- Oil Mist detector
- Mounting feet options (fixed or resilient)

RATINGS & FUEL CONSUMPTION

IMO II

Rating	mhp	bhp	bkW	rpm	U.S. g/h	g/bkW-hr	IMO	U.S. EPA	EU	China
CS	4704	4640	3460	900	208	193.8	II	NC	NC	NC
CS	5031	4962	3700	1000	239	206.6	II	NC	NC	NC
MC	5167	5096	3800	900	214	194.0	II	NC	NC	NC
MC	5520	5444	4060	1000	261	205.4	II	NC	NC	NC
MC	6118	6035	4500	1000	292	207.0	II	NC	NC	NC

IMO III / U.S. EPA Tier 4

Rating	mhp	bhp	bkW	rpm	U.S. g/h	g/bkW-hr	IMO	U.S. EPA	EU	China
CS	5031	4962	3700	1000	233	201.1	III	T4C	NC	NC
MC	5520	5444	4060	1000	255	200.4	III	T4C	NC	NC

C280 fuel rate is at full load on the prop curve, Brake Specific Fuel Consumption (BSFC) is at full power condition.

ISO 3046/1 BSFC tolerance of +/-5%.

Rating Definitions:

Continuous Service (CS) Rating is suitable for continuous duty applications, including dredges, for operation without interruption or load cycling.

Maximum Continuous (MC) Rating is generally used for vessel applications involving varying loads. The engine power actually produced is limited by application guidelines, leaving a power reserve for unusual operating conditions. Operating time at loads above the Continuous Service Ratings for a given rpm is limited to one hour in 12 or 8.3% of total operation hours.

ENGINE DIMENSIONS & WEIGHT

LENGTH	182 in / 4,623 mm
HEIGHT	134 in / 3,404 mm
WIDTH	80 in / 2,032 mm
DRY WEIGHT	57,276 lb / 25,980 kg

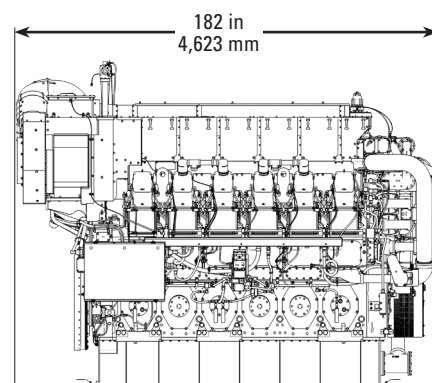
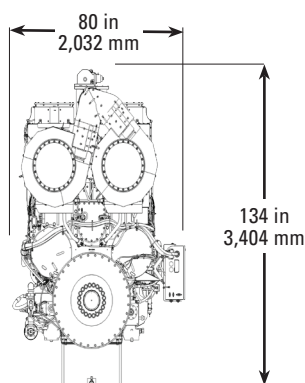

Contact your Local Cat® Dealer for more information!

