

# 5008A-E30TAG Electric Power Engines

Power range 1500 rpm

649-1094 kW (engine gross power)

Emissions

Fuel optimised

*The Perkins® 5008AC-E30TAG has been designed to offer reliable power for all electric power applications, including standby, prime, critical applications market and data centres.*

*Engineered and built specifically for the power generation market, the Perkins® 5000 Series is a power-packed engine range built to be dependable, versatile and offer lower emissions to meet regulatory standards.*

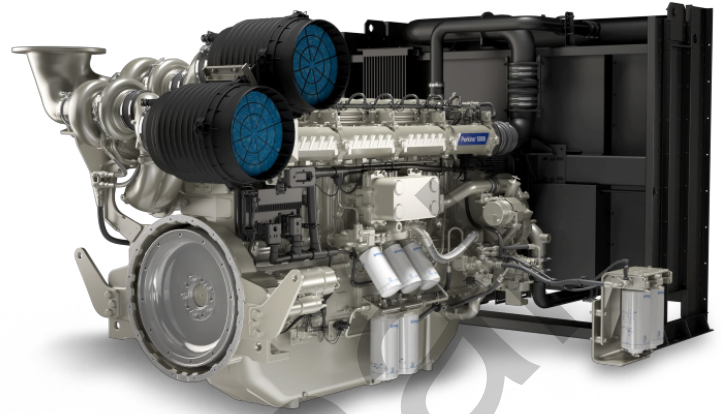

## Features and benefits

- The 5000 Series delivers **maximised productivity** through outstanding load acceptance, achieving NFPA110 Type 10 and ISO 8528-5 G2 and G3 performance class and deliver high altitude capability.

The engine build and performance have been designed from the ground up with **ultimate productivity and dependability** in mind, so customers can be confident that power will be available when required. They have been tested around the world, in the harshest environments, to deliver performance, no matter the conditions.

- Excellent oil consumption through dedicated piston, ring and liner assembly and low fuel consumption deliver **minimised daily operating costs**.

- Design of core engine components mean the 5000 Series **delivers more power**, more quickly no matter the demands of the application or the environment in which it is placed.

A single point customer electronics connection supports **ease of integration and service accessibility** is provided from a single side with 500 hours or two year oil and fuel service interval whichever comes first.

- The 5000 Series utilises **advanced technology**, with full authority electronics, that easily integrates into the customer's chosen telematic solutions and is optimised for efficiency in fuel consumption.

# 5008A-E30TAG Electric Power Engines

Power range 1500 rpm

649-1094 kW (engine gross power)

Emissions

Fuel optimised

## Specification

	5008A-E30TAG		
	TAG1	TAG2	TAG3
Configuration	Electro unit/ElectropaK		
Cylinders	8 vertical in-line, 4 stroke		
Displacement, litres (in3)	30.56 (1864.89)		
Aspiration	Turbocharged and air-to-air chargecooled		
Bore and stroke, mm (in)	160 × 190 (6.3 × 7.5)		
Combustion system	Direct injection		
Compression ratio	13.8:1		
Exhaust aftertreatment	N/A		
Rotation (viewed from flywheel)	Anti-clockwise		
Total lubricating oil capacity, litres (US gal)	153 (40)		
Cooling system	Watercooled		
Total coolant capacity, litres (US gal)	140 (37)		

## Technical Information

Model	Speed	Type of Operation	Engine Power		Typical Generator Output* (Net)		Prime Fuel Consumption			
			Gross	Net			ESP	100%	75%	50%
	rpm		kW (hp)	kW (hp)	kVA	kWe	g/kWh	g/kWh	g/kWh	g/kWh
5008A-E30TAG1	1500	Prime/DCP/LTP	804 (1078)	774 (1038)	909	728	194	194	195	198
		Standby/ESP	881 (1181)	851 (1141)	1000	800				
		COP	649 (870)	619 (830)	727	582	TBC			
5008A-E30TAG2	1500	Prime/DCP/LTP	890 (1193)	860 (1153)	1011	808	196	194	194	197
		Standby/ESP	987 (1324)	957 (1283)	1124	900				
		COP	718 (963)	688 (923)	808	647	TBC			
5008A-E30TAG3	1500	Prime/DCP/LTP	987 (1324)	957 (1283)	1124	900	202	195	193	199
		Standby/ESP	1094 (1467)	1064 (1427)	1250	1000				
		COP	796 (1067)	766 (1027)	900	720	TBC			

\*Generator powers are typical and based on typical alternator efficiencies and a power factor (cos θ) or 0.8.

5008 50 Hz platform has a 94% assumed alternator efficiency.

# 5008A-E30TAG Electric Power Engines

Power range 1500 rpm

649-1094 kW (engine gross power)

Emissions

Fuel optimised

## Standard Equipment

	5008A-E30TAG		
	TAG1	TAG2	TAG3
Electro unit or ElectropaK	Electro unit/ElectropaK		
Radiator fitted	Loose		
Fuel filter, engine mounted	✓		
Water separator	N/A		
Fuel priming pump (manual/electric)	Electric		
Fuel cooler (not required for most installations)	ElectropaK only		
Air filter, engine mounted	✓		
Engine ECM, engine mounted	✓		
Wiring harness to ECM	✓		
Wiring harness (all connectors to single customer interface)	✓		
Starter motor	✓		
Battery charging alternator	✓		
Flywheel housing	✓		
Flywheel	✓		
Fan	ElectropaK only		
Fan guard	ElectropaK only		
Temp and oil pressure for automatic stop/ alarm configurable	✓		

# 5008A-E30TAG Electric Power Engines

Power range 1500 rpm      649-1094 kW (engine gross power)

Emissions      Fuel optimised

## Engine Package Weights and Dimensions

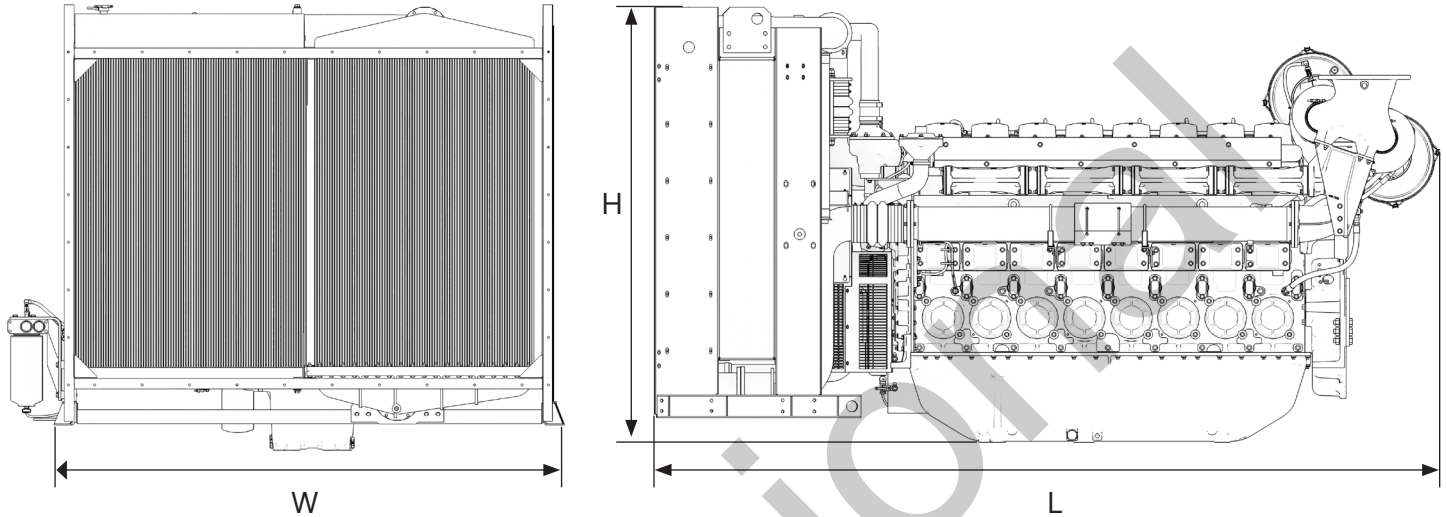

5008A-E30TAG		
TAG1 / TAG2 / TAG3		
Configuration	Electro unit	ElectropaK
Dimensions, H x L x W, mm (in)	1746.7 × 2716.88 × 1573.8 (68.7 × 107 × 62)	1919 × 3469 × 2194 (75.5 × 136.6 × 86.4)
Dry weight, kg (lb)	3455 (7616)	4360 (9612.2)

Continuous operating power (COP): Unlimited hours usage with an average load factor of 100 percent of the published continuous operating power. No overload is permitted on continuous operating power.

Prime power: Unlimited hours usage with an average load factor of 80 percent of the published prime power over each 24 hour period. A 10 percent overload is available for one hour in every 12 hours operation. No overload is permitted.

Data centre power (DCP): Power available for variable or continuous electrical loads in a data centre application. Up to 100 percent load factor of the published DCP power is permitted for unlimited time. An overload of 10 percent is permitted for one hour in every 12 hours of operation. No overload is permitted. DCP power definition relies on ISO8528-1 2018 standard to be followed by generator set manufacturer, and will support Tier I to Tier IV classifications of data centres as per UPTIME institute guidelines.

Standby power: Limited to 500 hours annual usage with an average load factor of 80 percent of the published standby power over each 24 hour period. Up to 300 hours of annual usage may be run continuously. No overload is permitted.

Limited-time running power (LTP): Maximum of 500 hours annual usage with an average load factor of 100 percent of the published LTP power.