



Cat[®] 303 CR

MINI EXCAVATOR

FEATURES:

The Cat[®] 303 CR Mini Excavator delivers power and performance in a compact size to help you work in a wide range of applications.

ALL DAY COMFORT

- Available as a canopy machine with adjustable wrist rests and utility space for a mobile phone to help keep you working comfortably all day long.

EASY TO OPERATE

- Controls are easy to use and the intuitive Next Generation LCD monitor provides easy to read machine information. An advanced touchscreen monitor can also be equipped.

STICK STEER TRAVEL MODE

- Moving around the job site is even easier with the Cat Stick Steer option. Easily switch from traditional travel controls with levers and pedals to joystick controls to move the machine and to operate the blade. The benefit of less effort and improved control is in your hands!

BIG PERFORMANCE IN A COMPACT DESIGN

- Strong lift and dig performance helps you get the job done faster. The compact radius design lets you access and work in the tightest areas. Dozer float allows for easy clean up.

SAFETY ON THE JOB SITE

- Your safety is our top priority. The Cat mini excavator is designed to help keep you safe on the job. Courtesy work lights and a fluorescent retractable seat belt are just a couple of the safety features we've built into the machine.

SIMPLE SERVICE FOR LESS DOWNTIME

- Maintenance is quick and easy on the Cat mini excavator. Routine check points are easy to access at ground level through the side doors. The unique tilt up canopy lets you reach additional service areas when needed.

LOWER OPERATING COSTS

- Equipped with features such as auto idle, auto engine shutdown, and efficient hydraulics with a variable displacement pump, the Cat mini excavator was designed with reducing your operating costs in mind.

UNMATCHED DEALER SUPPORT

- Your Cat dealer is here to help you reach your business goals. From providing equipment solutions to operator training to service needs and beyond, your Cat dealer is ready to help.

Specifications

Engine

Engine Model	C1.1 Turbo
Net Power @ 2,400 rpm ISO 9249, 80/1269/EEC	17.6 kW
Gross Power @ 2,400 rpm SAE J1995:2014	18.4 kW
Bore	77.0 mm
Stroke	81.0 mm
Displacement	1.1 L

- Meets EU Stage V emission standards.
- Net power advertised is the power available at the flywheel when the engine is at rated speed and rated power when the engine is installed with the factory configured fan, air intake system, exhaust system, and alternator with a minimum alternator load.
- Advertised power is tested per the specified standard in effect at the time of manufacture.

Weights

Minimum Operating Weight with Canopy*	3105 kg
Maximum Operating Weight with Canopy**	3480 kg

*Minimum Weight is based on rubber tracks, operator, full fuel tank, standard stick, blade, bucket and no extra counterweight.

**Maximum Weight is based on steel tracks, operator, full fuel tank, standard stick, blade, bucket and extra counterweight.



303 CR Mini Excavator

Weight Increase from Minimum Configuration

Counterweight (extra)	250 kg
Steel Tracks	125 kg

Travel System

Travel Speed – High	4.5 km/h
Travel Speed – Low	2.6 km/h
Maximum Traction Force – High Speed	14.7 kN
Maximum Traction Force – Low Speed	31.4 kN
Ground Pressure – Minimum Weight	28.3 kPa
Ground Pressure – Maximum Weight	32.8 kPa
Gradeability (maximum)	30 degrees

Service Refill Capacities

Cooling System	4.0 L
Engine Oil	4.0 L
Fuel Tank	45.0 L
Hydraulic Tank	18.0 L
Hydraulic System	35.0 L

Hydraulic System

Load Sensing Hydraulics with Variable Displacement Piston Pump	
Pump Flow @ 2,400 rpm	100 L/min
Operating Pressure – Equipment	245 bar
Operating Pressure – Travel	245 bar
Operating Pressure – Swing	176 bar
Auxiliary Circuit – Primary	
Flow*	65 L/min
Pressure*	245 bar
Digging Force – Stick (standard)	16.6 kN
Digging Force – Bucket	28.4 kN

*Flow and pressure are not combinable. Under load, as flow rises pressure goes down.

Swing System

Machine Swing Speed	9.0 rpm
Boom Swing – Left	75 Degrees
Boom Swing – Right	50 Degrees

Blade

Width	1550 mm
Height	350 mm

Certification – Canopy

Roll Over Protective Structure (ROPS)	ISO 12117-2:2008
Tip Over Protective Structure (TOPS)	ISO 12117:1997
Top Guard	ISO 10262:1998 (Level I)

Sound

Operator Sound Pressure (ISO 6396:2008)	78 dB(A)
Average Exterior Sound Pressure (ISO 6395:2008)	94 dB(A)

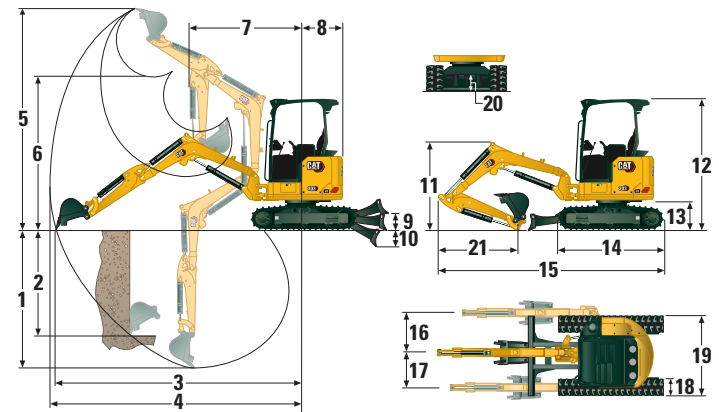

Dimensions

	Standard Stick
1 Dig Depth	2650 mm
2 Vertical Wall	1820 mm
3 Maximum Reach at Ground Level	4830 mm
4 Maximum Reach	4980 mm
5 Maximum Dig Height	4510 mm
6 Maximum Dump Clearance	3170 mm
7 Boom in Reach	1750 mm
8 Tail Swing	
without Counterweight	775 mm
with Counterweight (extra)	890 mm
9 Maximum Blade Height	385 mm
10 Maximum Blade Depth	535 mm
11 Boom Height in Shipping Position	1600 mm
12 Overall Shipping Height	2480 mm
13 Swing Bearing Height	570 mm
14 Overall Undercarriage Length	2070 mm
15 Overall Shipping Length†	4510 mm
16 Boom Swing Right	870 mm
17 Boom Swing Left	640 mm
18 Track Belt/Shoe Width	300 mm
19 Track Width	1550 mm
20 Ground Clearance	310 mm
21 Stick Length	1260 mm

†Overall Shipping Length depends on blade position during shipment.

Canopy

Lift Capacities – Minimum Configuration			Lift Point Radius – 2 m			Lift Point Radius – 3 m			Lift Point Radius (Maximum)			
			Over Front		Over Side	Over Front		Over Side	Over Front		Over Side	m
Lift Point Height			Blade Down	Blade Up		Blade Down	Blade Up		Blade Down	Blade Up		
3 m	Standard Stick	kg				*792	603	526	*848	420	368	3.67
2 m	Standard Stick	kg				*998	574	498	*864	331	289	4.16
1 m	Standard Stick	kg				*1352	526	453	*903	304	264	4.29
0 m	Standard Stick	kg	*1280	952	784	*1522	498	426	*955	317	275	4.11

Minimum Weight includes canopy, rubber tracks, no extra counterweight, operator, full fuel tank and blade.

Lift Capacities – Maximum Configuration			Lift Point Radius – 2 m			Lift Point Radius – 3 m			Lift Point Radius (Maximum)			
			Over Front		Over Side	Over Front		Over Side	Over Front		Over Side	m
Lift Point Height			Blade Down	Blade Up		Blade Down	Blade Up		Blade Down	Blade Up		
3 m	Standard Stick	kg				*792	774	627	*848	552	449	3.67
2 m	Standard Stick	kg				*998	746	600	*864	443	359	4.16
1 m	Standard Stick	kg				*1352	698	555	*903	412	332	4.29
0 m	Standard Stick	kg	*1280	1269	954	*1522	670	529	*955	431	346	4.11

Maximum Weight includes canopy, steel tracks, extra counterweight, operator, full fuel tank and blade.

*The above loads are in compliance with hydraulic excavator lift capacity rating standard ISO 10567:2007 and they do not exceed 87% of hydraulic lifting capacity or 75% of tipping capacity. The excavator bucket weight is not included on this chart. Lifting capacities are for standard stick.

303 CR Mini Excavator

Standard and Optional Equipment

Standard and optional equipment may vary. Consult your Cat dealer for details.

	Standard	Optional		Standard	Optional
ENGINE					
Cat® C1.1 Turbo Engine (EU Stage V)	✓		OPERATOR ENVIRONMENT (continued)		
Automatic Engine Idle	✓		Next Generation Color LCD Monitor (IP66)	✓	
Automatic Engine Shutdown	✓		– Fuel Level and Coolant Temperature Gauges	✓	
Automatic Two Speed Travel	✓		– Maintenance and Machine Monitoring	✓	
Fuel Water Separator	✓		– Performance and Machine Adjustments	✓	
Power on Demand (not available in all regions)	✓		– Numeric Security Code	✓	
Variable Displacement Piston Pump	✓		– Multiple Languages	✓	
Load Sensing/Flow Sharing Hydraulics	✓		– Hour Meter with Wake Up Switch	✓	
HYDRAULICS					
Smart Tech Electronic Pump	✓		Next Generation Advanced Monitor		✓
Accumulator	✓		– Touch Screen		✓
Automatic Swing Brake	✓		– Site Reference System		✓
One and Two Way Auxiliary Flow	✓		– High Definition Camera Capable (IP68 and IP69K)		✓
Continuous Auxiliary Flow	✓		– Numeric Security Code		✓
Auxiliary Hydraulic Lines		✓	UNDERCARRIAGE		
Auxiliary Line Ball Valve Connect		✓	Rubber Belt (300 mm wide)		✓
OPERATOR ENVIRONMENT					
Tilt-up Canopy	✓		Steel Track (300 mm wide)	✓	
Top Guard ISO 10262:1998 Level I	✓		Dozer Blade	✓	
ROPS – ISO 12117-2:2008	✓		Dozer Blade Float	✓	
TOPS – ISO 12117:1997	✓		Tie Downs on Track Frame	✓	
Stick Steer Mode	✓		BOOM, STICK AND LINKAGES		
Travel Cruise Control	✓		One Piece Boom (2200 mm)	✓	
Control Pattern Changer (optional in some regions)	✓		Standard Stick (1260 mm)	✓	
Adjustable Wrist Rests	✓		ELECTRICAL		
Washable Floor Mat	✓		12 Volt Battery	✓	
Travel Pedals and Hand Levers	✓		Software (machine and monitor)	✓	
Machine Security	✓		Maintenance Free Battery	✓	
Standard Key with Pass Code	✓		Battery Disconnect	✓	
Vinyl Non Suspension Seat	✓		12 Volt Power Socket	✓	
Hydraulic Lockout – All Controls	✓		Product Link™ PL243 (regulations apply)	✓	
Retractable High Visibility Seat Belt (76 mm)	✓		OTHER		
Coat Hook	✓		Extra Counterweight (250 kg/551 lb)		✓
Cup Holder	✓				
Storage Pocket	✓				
Skylight	✓				
Mounting Bosses for Front	✓				
LED Front Lights		✓			
LED Boom Light		✓			
Utility Space for Mobile Phone	✓				

For more complete information on Cat products, dealer services, and industry solutions, visit us on the web at www.cat.com

© 2022 Caterpillar
All rights reserved

Materials and specifications are subject to change without notice. Featured machines in photos may include additional equipment. See your Cat dealer for available options.

CAT, CATERPILLAR, LET'S DO THE WORK, their respective logos, "Caterpillar Corporate Yellow," the "Power Edge" and Cat "Modern Hex" trade dress as well as corporate and product identity used herein, are trademarks of Caterpillar and may not be used without permission.

AEHQ8411-00 (04-2022)
Build Number: 07A
(India)

