



Cat[®] 907

COMPACT WHEEL LOADER

FEATURES:

CONFIGURED FOR SUCCESS

- Cat[®] wheel loaders set the standard for productivity, fuel efficiency and operator comfort. The Cat 907 Compact Wheel Loader has a high torque C2.8 engine that works in conjunction with an intelligent hystat power train to deliver exceptional fuel efficiency. This engine meets U.S. EPA Tier 4 Final and EU Stage V emission standards with a clean emission module designed to manage itself so you can concentrate on the task at hand.

ENJOY ALL DAY COMFORT

- All new cab is spacious, quiet and comfortable with all around 360° visibility to keep you productive throughout the day. Seat-mounted controls feature a multifunction joystick for lift and tilt functions with an integrated thumb operated speed range, forward/neutral/reverse (FNR) switch, trigger operated differential lock and constant flow. Optional fourth function joystick also available.
- Digital display with soft touch buttons for customized settings to easily control linkage and drive train to further enhance operator comfort and safety.

EFFICIENTLY POWERFUL

- Cat C2.8 engine provides a cleaner, quieter operation while delivering superior performance and durability through a high torque, low speed design. Caterpillar's exclusive Intelligent Power Management system monitors operator input and available power to keep the machine working at peak efficiency.
- "Shift on the go" locking differentials and hydrostatic transmission provide smooth and powerful operation while increasing the efficiency of machine cycles. Single Pedal Mode via the display enables right pedal machine operation giving further improved operator controllability of attachment RPM versus machine ground speed over creep control and inching pedal.

WORK MADE EASY

- All-in-one joystick to keep eyes on the work while maximizing operation of hydro-mechanical attachments with a state of the art pressure compensated electro-hydraulic system. Optimized Z-bar linkage for great performance and versatility with buckets that now have the DNA of the larger Cat loaders, such as curved side plates and a flat torque tube for parallel reference to the cutting edge.

CUSTOMIZE YOUR EXPERIENCE

- Work as one with your machine by customizing the controls. Operator can adjust machine responsiveness with the push of a button based on the attachment or application. Once customized, settings can be locked with "simplified mode" to ensure the machine is consistent and intuitive for every user.
- Machine security is enhanced with a standard keycode or optional Bluetooth[®] technology.

PURPOSE BUILT SPECIALITY MODELS

- Machines can be built to meet industry and application specific needs: Agriculture, General Construction, Industrial and Waste, Landscaping or Snow Removal.
- The 907 has the following specific handler arrangements:
 - Ag Handler
 - Waste Handler

AFTERMARKET AND SERVICES

- Range of services and aftermarket retrofits and upgrades available to keep your machine going and configured for your application.
- Service and maintenance parts available, including a range of self-service options (SSO) and dealer installed kits.
- Integrated Technology available to reduce service costs and maintenance.

907 Compact Wheel Loader

Purpose Built Specific Handlers

A complete range of optional equipment and work tool attachments gives you the versatility to configure a handler package to be successful in your business. Get with Caterpillar to configure yours.

AG HANDLER



Recommended options for an AG Handler:

- Reversing fan
- AG tires
- LED roading lights
- LED work lights
- Camera, front or rear
- Full range of work tool attachments

WASTE HANDLER



Recommended options for a Waste Handler:

- Reversing fan
- Light guarding, front and rear
- Tire options (solid or pneumatic)
- LED work lights
- Camera, front or rear
- Seatbelt notification, green beacon option
- Backup alarm
- Light material or grapple buckets

Specifications

Engine

Engine Model	Cat® C2.8*	
Maximum Engine Speed	2,550 rpm	
Maximum Gross Power		
Rated Engine Speed	2,400 rpm	
SAE J1995	55.7 kW	74.7 hp
ISO 14396	55.4 kW	74.3 hp
ISO 14396 (metric)	75.3 mhp	
Rated Net Power		
Rated Engine Speed	2,400 rpm	
SAE J1349	54.2 kW	72.7 hp
ISO 9249	53.8 kW	72.1 hp
ISO 9249 (metric)	73.1 mhp	
Maximum Gross Torque#		
SAE J1995	300 N-m	222 lb-ft
ISO 14396	300 N-m	221 lb-ft
Maximum Net Torque#		
SAE J1349	296 N-m	218 lb-ft
ISO 9249	295 N-m	217 lb-ft

Engine (continued)

Displacement	2.8 L	171 in ³
Bore	90 mm	3.54 in
Stroke	110 mm	4.33 in

- Advertised power is tested per the specified standard in effect at the time of manufacture.
- Net power advertised is the power available at the flywheel.

*Two Cat C2.8 engine emission options are available:

- 1) Meets U.S. EPA Tier 4 Final, EU Stage V.
- 2) U.S. EPA Tier 3 and EU Stage IIIA equivalent. Tier 3 engine specs are 0.3 kW/0.4 hp more gross power (SAE J1995), 0.2 kW/0.3 hp on net power (SAE J1349) and 1 N-m/0.7 lb-ft higher on gross torque (SAE J1995).

#Maximum gross and net torque measured at 1,600 rpm.

Specifications (continued)

Buckets

Bucket Capacities – General Purpose	0.80-1.35 m ³	1.0-1.7 yd ³
Bucket Capacities – Multi Purpose	0.75-1.1 m ³	1.0-1.4 yd ³
Bucket Capacities – Light Material	1.25-1.55 m ³	1.6-2.0 yd ³

- Bucket selection must be made with an understanding of the material density and application to ensure machine stability is maintained within the tipping loads stated per model and configuration.
- Bucket capacities stated include bolt-on cutting edge (BOCE), in line with ISO 7546.

Transmission

Forward and Reverse:

Speed Range Creep#	10 km/h	6 mph
Speed Range 1*	10 km/h	6 mph
Speed Range 2** – High Speed	17 km/h	10.5 mph
Speed Range 2** – Standard	20 km/h	12 mph
Speed Range 3***	40 km/h	25 mph

#Factory default shown, can be adjusted to any speed up to 19 km/h (12 mph).

*Creep function not available in this gear or above.

**Max speed dependent on model and configuration (standard vs. high speed transmission).

***Reverse is 30 km/h (19 mph).

Tires

Standard Size	405/70 R18 Powerloads*
Other Choices Include:	340/80 R18 XMCL/Bibload 340/80 R18 TRI 2 40X14-20 TL, SM/TR 340/80 R18 Duraforce

- Other tire choices are available. Contact your Cat dealer for details.
- Caterpillar recommends that you consult a tire supplier to evaluate all conditions before selecting a tire model.

*This tire has been used for all dimension, stability and performance data.

Service Refill Capabilities

Fuel Tank (including filter and lines)	90 L	24 gal
Cooling System	12 L	3.2 gal
Engine Crankcase	8.8 L	2.3 gal
Axles – Front Center Differential	8.8 L	2.3 gal
Axles – Rear Center Differential	8.8 L	2.3 gal
Hydraulic System (including tank)	67.5 L	17.8 gal
Hydraulic Tank	44.6 L	11.8 gal
Transmission	2.4 L	0.6 gal

- No Diesel Exhaust Fluid (DEF) fluid needed on this size engine.

Axles

Front	Fixed (standard) Locking Differential (optional)
Rear	Fixed (standard) Locking Differential (optional)

- Oscillation of ±11 degrees via hitch between front and rear frames.

Steering

Steering Articulation Angle (each direction)	39°
Maximum Flow – Steering Pump	46.7 L/min 12.3 gal/min
Maximum Working Pressure – Steering Pump	23 000 kPa 3,336 psi
Steering Cycle Times – (full left to full right) – at High Idle	2.8 sec
Number of Steering Wheel Turns – Full Left to Full Right or Full Right to Full Left	3.25 turns 4.00 turns

Cab

ROPS ISO 3471:2008

FOPS ISO 3449:2005 Level II

- Canopy and cab, Rollover Protective Structures (ROPS) are available worldwide. Canopy not available in Europe (EU).

Loader Hydraulic System

Main Relief – 1st Auxiliary (3rd slice)	23 500 kPa	3,408 psi
Standard Flow*	80 L/min	21 gal/min
High Flow*	120 L/min	32 gal/min
Main Relief – 2nd Auxiliary (4th slice)	23 500 kPa	3,408 psi
Flow	45 L/min	12 gal/min
Hydraulic Cycle Time		
Rack Back	2.2 seconds	
Lift	5.0 seconds	
Dump	1.6 seconds	
Float down	2.8 seconds	

*Maximum flow stated, actual flow delta could be 6% from data shown. Also adjustable from 20% to 100% of maximum flow through display.

907 Compact Wheel Loader

AFTERMARKET, RETROFIT and UPGRADE KITS

Machine upgrade and aftermarket kits are available for retrofit, either as a self-service option or dealer installed.

Dealer Installed Kits/Upgrades

- Couplers
- Joystick Kits
- Keypad Options
- Reversing Fan
- Ride Control
- Rotary Sensor and Kickouts
- Work Tool Harness
- Auxiliary Hydraulics Kits
- Product Link™ Elite
- Starting Aids
- Electric Fuel Priming Pump
- Camera (front or rear)
- Bluetooth® Security

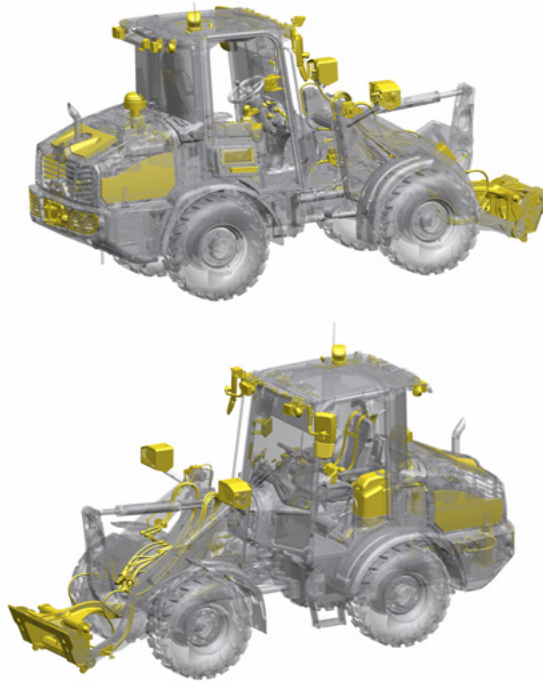

Self-service or Dealer Installed Kits/Upgrades

- Lighting Packages
- Storage Box or Cool Storage Box
- Toolbox
- Seatbelt Packages
- Cab Filters Kits
- Cell Phone Holder Options
- Radio Kit
- Engine Pre-cleaner
- Push to Start Kit
- Mirror Packages
- Rear Hitch Ready Kit
- Engine Sound Suppression

ATTACHMENTS

Get more from your machine with Cat attachments. Choose from a wide variety of options and tailor your machine to different tasks and conditions.

- Augers
- Bale Grabs
- Bale Spears
- Blades
- Brooms
- Brushcutters
- Buckets
- Cold Planers
- Compactors
- Fork Tines and Carriages
- Material Handling Arm
- Nursery Forks
- Rakes, Landscape and Power Box
- Snow Blowers
- Snow Plows
- Snow Pushes
- Snow Wings
- Stump Grinders
- Tillers
- Trenchers
- Wheel Saws



907 Compact Wheel Loader

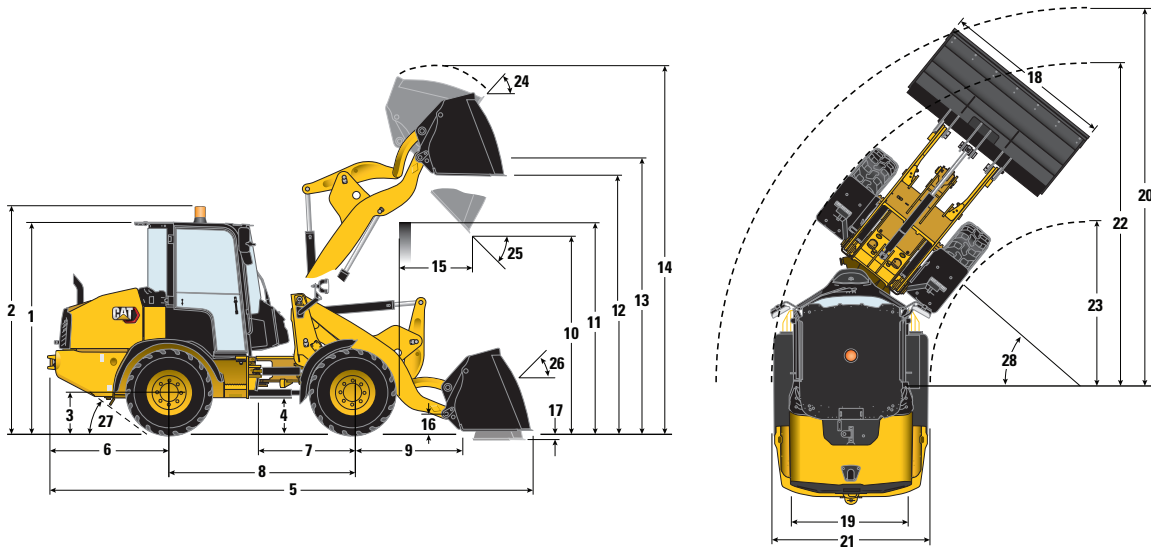

Dimensions

	Horizontal Pin Lock Coupler (HPL-V)#		Vertical Pin Coupler (SSL)	
	mm	ft/in	mm	ft/in
**1 Height: Ground to Cab	2567	8'5"	2566	8'5"
**2 Height: Ground to Beacon	2749	9'0"	2749	9'0"
**3 Height: Ground Axle Center	455	1'6"	455	1'6"
**4 Height: Ground Clearance	275	0.11"	275	0.11"
*5 Length: Overall	5366	17'7"	5525	18'2"
6 Length: Rear Axle to Bumper	1391	4'7"	1391	4'7"
7 Length: Hitch to Front Axle	1085	3'7"	1085	3'7"
8 Length: Wheel Base	2170	7'1"	2170	7'1"
9 Length: Front Axle to Front of Coupler	1065	3'6"	1316	4'4"
*10 Clearance: Bucket at 45°	2480	8'2"	2367	7'9"
**11 Clearance: Load over Height	2877	9'5"	2877	9'5"
**12 Clearance: Level Bucket	3012	9'11"	3003	9'10"
**13 Height: Bucket Pin	3226	10'7"	3226	10'7"
**14 Height: Overall	4097	13'5"	4187	13'9"
*15 Reach: Bucket at 45°	689	2'3"	813	2'8"
16 Carry Height: Bucket Pin	299	1'0"	321	1'1"
**17 Dig Depth	138	0'5"	110	0'4"
18 Width: Bucket	2045	6'9"	2045	6'9"
19 Width: Tread Center	1420	4'8"	1420	4'8"
20 Turning Radius: Over Bucket	4489	14'9"	4563	15'0"
21 Width: Over Tires	1708	5'6"	1708	5'6"
22 Turning Radius: Outside of Tires	3901	12'10"	3901	12'10"
23 Turning Radius: Inside of Tires	2052	6'7"	2052	6'7"
24 Rack Angle at Full Lift	56°		51°	
25 Dump Angle at Full Lift	45°		50°	
26 Rack Angle at Carry	51°		46°	
27 Departure Angle	30°		30°	
28 Articulation Angle	39°		39°	

	Horizontal Pin Lock Coupler (HPL-V)#		Vertical Pin Coupler (SSL)	
	kg	lb	kg	lb
Operating Weight: Bucket [^]	5808	12,804	5894	12,944
Tipping Load – Straight – ISO 14397-1†	4503	9,927	3995	8,807
Tipping Load – Full Turn – ISO 14397-1†	3875	8,544	3432	7,566
Operating Weight: Carriage and Tines ^{^^}	5559	12,255	5647	12,450
Tipping Load – Straight – ISO 14397-1†	3611	7,961	3434	7,571
Tipping Load – Full Turn – ISO 14397-1†	3120	6,878	2982	6,574
80% of Full Turn Tip: Firm and Level EN474-3††	2496	5,503	2386	5,259

* Vary with bucket

** Vary with tire

[^] HPL-V or SSL, 1.05 m³ (1.4 yd³) general purpose bucket.

^{^^} HPL-V or SSL, class II carriage, 1220 mm (4 ft) tines (500 mm [20 in] load center).

† Full compliance to ISO 14397-1 (2007) Sections 1 thru 6 (fork 500 mm [20 in] load center), which requires 2% verification between calculation and testing.

†† Full compliance to EN474-3 and SAE J1197.

HPL-A weight, tipping and rated loads are within 1% of the HPL-V.

Dimensions listed are for a machine configured with standard cab, heater, 20 km/h (12 mph), standard guarding, 80 kg (176 lb) operator, full fluids, Goodyear POWERLOAD® 405/70 R18 tires and 1.05 m³ (1.4 yd³) general purpose bucket with bolt-on cutting edge or a class II fork carriage and tines (tire supplier variability can impact dimensions by 2%).

907 Compact Wheel Loader

STANDARD EQUIPMENT

POWER TRAIN

- U.S. EPA Tier 4 Final and EU Stage V emissions compliant
- Cat C2.8 engine
 - Diesel particulate filter (Fit for Life)
 - Fuel, diesel, ultra low or low Sulphur
 - Hydrostatic transmission, two speed, with inching function, “shift on the go”
 - Power train mode, hystat
- Air cleaner, two stage filter, with in cab audio/visual indicator on display
- Axles, heavy duty, frame mounted with outboard planetary reduction
- Closed circuit breather
- Coolant, extended life, -36° C (-33° F)
- Drive shaft, sealed for life, universal joints
- Engine, auto idle shutdown, hibernation mode
- Engine oil, ECO drain tap and hose
- Fuel pump, priming (manual)/water separator/drain

HYDRAULICS

- Caterpillar HYDO™ Advanced 10 hydraulic oil
- Coupler/pin on attachment ready
- Demand cooling fan, hydraulically driven
- Dead engine lower, lift valve, manual
- Electro-hydraulic, fully proportional controls
- Hydraulic pilot shut off switch, in cab
- Hystat displacement pump, infinitely variable
- Implement valve, pressure compensated
- Joystick, single lever, single auxiliary roller
- Multi-function lift and tilt with loader arm float
- Motor, single drive with dedicated implement and steering pumps

ELECTRICAL

- Alternator, 100 amp sealed
- Battery, heavy duty, 12V, 90Ah and 1,000 CCA
- Battery disconnect switch
- Cab mounted fuse panel
- Lights, rear stop and turn, LED
- Lights, roading, front halogen
- Service (Electronic Technician™)
- Product Link™

OPERATOR ENVIRONMENT

- ROPS/FOPS certified canopy/cab
 - 12V power outlets, interior/exterior
 - Pedals, raised, foot, brake/inching, accelerator
 - Lever, parking brake
 - Cup holders (2)

- CB radio clip, phone holder
- Door release, internal (left and right)
- Hook, large, coat and hard hat
- Floormat, heavy duty, easy clean
- Mirrors, (2) external breakaway, (1) internal
- Operator station on isolation mounts
- Steering wheel, spinner knob, horn in center
- Seat belt, orange, retractable, 51 mm (2 in)
- Storage, personal (trays [3], seat pocket)
- Steering column, tilt adjusted
- Column mounted multi function control: lights, roading, wipers, self cancelling turn signals
- Quick coupler switch, in cab
- Display, analog and digital
- Gauges (2), hydraulic oil, engine coolant
- Digital with soft touch buttons – fuel level, speed range, speedometer, service hour meter, service/maintenance information, hydraulic and power train performance and aggressiveness settings, security passcode (multiple languages)
- Joystick, seat mounted, standard multifunction
 - FNR, auxiliary roller, speed range select, continuous flow, differential lock, horn
 - Arm rest, padded right, multiple position vertical height
- Seat, manual height adjustment, (cab) fabric with adjustable left arm rest, (canopy) vinyl
- Cab
 - Doors (2), fixed glass
 - Wipers, front and rear, full front coverage
 - Windshield, front single piece
 - Window, rear heated
 - Radio ready, speakers and wiring
 - Air vents, (4) screen, (7) directional
 - Heating, mechanical control unit
 - Sun visor, solid, front full width
 - Interior light (incandescent)

OTHER

- Fenders, front and rear
- Ground level easy access daily service points
- Loader arm safety brace
- Lockable main and side engine enclosures
- Lockable, fuel cap, HVAC filters, nose cone
- Machine lifting/tie down points
- Paint, Electro-Coat primer, gloss topcoat
- Recovery hitch with pin
- Scheduled Oil Sampling (S-O-SSM) ports, engine oil and hydraulic oil

OPTIONAL EQUIPMENT

POWER TRAIN

- Antifreeze, extended life coolant, -50° C (-58° F)
- Cold start – jacket water heater, bypass valve
- Creep and throttle lock function
- Fuel pump, priming, manual
- 40 km/h (25 mph) hydrostatic transmission, 3-speed, “shift on the go”, secondary steering and boosted brakes
- Single Pedal mode (includes keypad)

ELECTRICAL

- Lighting packages, multiple; front, rear, engine bay (LED or HAL)
- Push to start
- Work tool wiring harness, (3) in cab switches

HYDRAULICS

- Auxiliary flow, single standard (3) valve, single high flow (3) valve, dual high flow (4) valve
- Caterpillar Bio HYDO Advanced hydraulic oil
- Connect under pressure and case drain
- Ride Control or load check valves
- Reversing fan
- Quick disconnect auxiliary hydraulics

OPERATOR STATION

- Air Conditioning, automatic temperature control (ATC)
- Doors, sliding windows (left and right)
- Interior light, door activated
- Joystick, FNR, twin auxiliary roller, differential lock, horn
- Mirrors (2) electronically adjustable, heated external, plus lower parabolic mirror
- Phone holder, spring loaded
- Radio, FM or digital audio broadcast
- Seat belt options, multiple
- Seat packages; deluxe or premium
- Secondary display, front or rear view camera
- Soft touch keypad options, 8 or 16 button
- Storage, lockable box or lockable cooled box
- Sun visor, rear perforated
- USB ports (2), interior

OTHER

- Couplers, vertical (SSL), horizontal (HPL-V, HPL-A)
- Rotary sensors (snubbing, kickouts, parallel)

The following information applies to the machine at the time of final manufacture as configured for sale in the regions covered in this document. The content of this declaration is valid as of the date issued; however, content related to machine features and specifications are subject to change without notice. For additional information, please see the machine's Operation and Maintenance Manual.

For more information on sustainability in action and our progress, please visit <https://www.caterpillar.com/en/company/sustainability>.

Engine

- The Cat® C2.8 engine meets U.S. EPA Tier 4 Final and EU Stage V emission standards.
- Cat diesel engines are required to use ULSD (ultra-low sulfur diesel fuel with 15 ppm of sulfur or less) or ULSD blended with the following lower-carbon intensity fuels up to:
 - ✓ 20% biodiesel FAME (fatty acid methyl ester)
 - ✓ 100% renewable diesel, HVO (hydrotreated vegetable oil) and GTL (gas-to-liquid) fuels
 Refer to guidelines for successful application. Please consult your Cat dealer or "Caterpillar Machine Fluids Recommendations" (SEBU6250) for details.

Air Conditioning System

- The air conditioning system on this machine contains the fluorinated greenhouse gas refrigerant R134a (Global Warming Potential = 1430). The system contains 0.83 kg (1.8 lb) of refrigerant which has a CO₂ equivalent of 1.216 metric tonnes (1.34 tons).

Paint

- Based on best available knowledge, the maximum allowable concentration, measured in parts per million (PPM), of the following heavy metals in paint are:
 - Barium < 0.01%
 - Cadmium < 0.01%
 - Chromium < 0.01%
 - Lead < 0.01%

Sound Performance

With cooling fan speed at maximum value:

Operator Sound Pressure Level (ISO 6396:2008) – 71 dB(A)*
Exterior Sound Power Level (ISO 6395:2008) – 101 dB(A)**
Exterior Sound Pressure Level (SAE J88:2013) – 99 dB(A)**

*Measurements were conducted with properly installed and maintained cab doors and windows closed.

**The labeled sound power level for the CE and UK marked configurations when measured according to the test procedure and conditions specified in 2000/14/EC and UK Noise Regulation 2001 No. 1701.

Oils and Fluids

- Caterpillar factory fills with ethylene glycol coolants. Cat Diesel Engine Antifreeze/Coolant (DEAC) and Cat Extended Life Coolant (ELC) can be recycled. Consult your Cat dealer for more information.
- Cat Bio HYDO Advanced is an EU Ecolabel approved biodegradable hydraulic oil.
- Additional fluids are likely to be present, please consult the Operations and Maintenance Manual or the Application and Installation guide for complete fluid recommendations and maintenance intervals.

Features and Technology

- The following features and technology may contribute to fuel savings and/or carbon reduction. Features may vary. Consult your Cat dealer for details.
 - Engine Idle Hibernate Mode
 - Engine Idle Shutdown
 - Advanced Electro Hydraulics
 - Efficient HVAC
 - Engine Demand Fan
 - Aftertreatment Low Idle Regeneration Strategy
 - Hydrostatic Transmission
 - Shift On the Go Transmission
 - Remote Flash and Remote Troubleshoot
 - Long Life Structural Durability

Recycling

- The materials included in machines are categorized as below with approximate weight percentage. Because of variations of product configurations, the following values in the table may vary.

Material Type	Weight Percentage
Steel	60.35%
Iron	16.88%
Nonferrous Metal	3.48%
Mixed Metal	1.05%
Mixed-Metal and Nonmetal	0.91%
Plastic	2.24%
Rubber	4.25%
Mixed Nonmetallic	0.04%
Fluid	3.35%
Other	3.72%
Uncategorized	3.71%
Total	100.00%

- A machine with higher recyclability rate will ensure more efficient usage of valuable natural resources and enhance End-of-Life value of the product. According to ISO 16714 (Earthmoving machinery – Recyclability and recoverability – Terminology and calculation method), recyclability rate is defined as percentage by mass (mass fraction in percent) of the new machine potentially able to be recycled, reused, or both.

All parts in the bill of material are first evaluated by component type based on a list of components defined by the ISO 16714 and Japan CEMA (Construction Equipment Manufacturers Association) standards. Remaining parts are further evaluated for recyclability based on material type.

Because of variations of product configurations, the following value in the table may vary.

Recyclability – 93%

907 Compact Wheel Loader

For more complete information on Cat products, dealer services, and industry solutions, visit us on the web at www.cat.com

© 2024 Caterpillar
All rights reserved

Materials and specifications are subject to change without notice. Featured machines in photos may include additional equipment. See your Cat dealer for available options.

CAT, CATERPILLAR, LET'S DO THE WORK, their respective logos, "Caterpillar Corporate Yellow," the "Power Edge" and Cat "Modern Hex" trade dress as well as corporate and product identity used herein, are trademarks of Caterpillar and may not be used without permission.

AEHQ8413-03 (06-2024)
Replaces AEHQ8413-02
Build Number: 14A
(N Am, EU, AUZ, Turkey)

