

POWER BOX RAKES

FOR SKID STEER LOADERS, COMPACT TRACK LOADERS,
AND COMPACT WHEEL LOADERS



Models
PR118, PR121, PR123

Machine Compatibility
226D3-299D3, 906-908

Current machines listed. Machine model availability and attachment vary by region. Contact your local Cat dealer for exact compatibility and availability.



Cat® power box rakes are ideal for clearing and preparing soil in general construction trench restoration, golf course construction and athletic field maintenance. They offer the versatility to de-thatch, remove old lawns and weeds, grade, level, rake, remove debris and prepare seedbeds with one work tool. Their angling ability allows the operator to windrow collected debris for easy pickup and removal.

MANUAL OR HYDRAULIC ANGLING



Manual or hydraulic angling up to 20 degrees right or left of center. Hydraulic angling option allows the operator to control the power box rake angle from the operator compartment.

DUAL INDEPENDENTLY ADJUSTABLE WHEELS

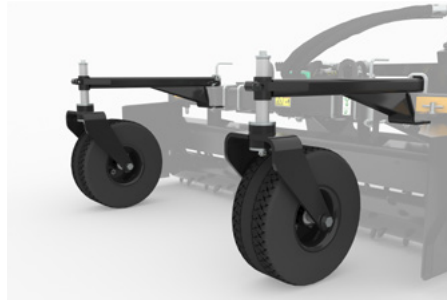

Dual independently adjustable gauge wheels allow for skim passes for over-seeding or adjust to cut drainage grades.

CONSISTENT MILLING



Consistent milling action creates an ideal seedbed for great germination results, laying the groundwork for a perfect lawn. Wet, dry, weedy, hard and rocky soil can be dried, flattened, pulverized and conditioned for seed in one step.

SERRATED STEP



Wide access step with grating and large profile serrations provides better traction for entering and exiting the cab.

TWO-POSITION WINGED ENDPLATES



Two-position winged endplates allow close raking to side walks or foundations. They can remain parallel, even during angling, for smoother plowing.

TOOL MOUNTED OPERATION AND MAINTENANCE MANUAL CONTAINER



Tool mounted and sealed from the elements, the Operation and Maintenance Manual is stored in a durable container for quick reference.



Standard two year warranty gives you peace of mind when purchasing a quality Cat® power box rake attachment.

POWER BOX RAKES SPECIFICATIONS

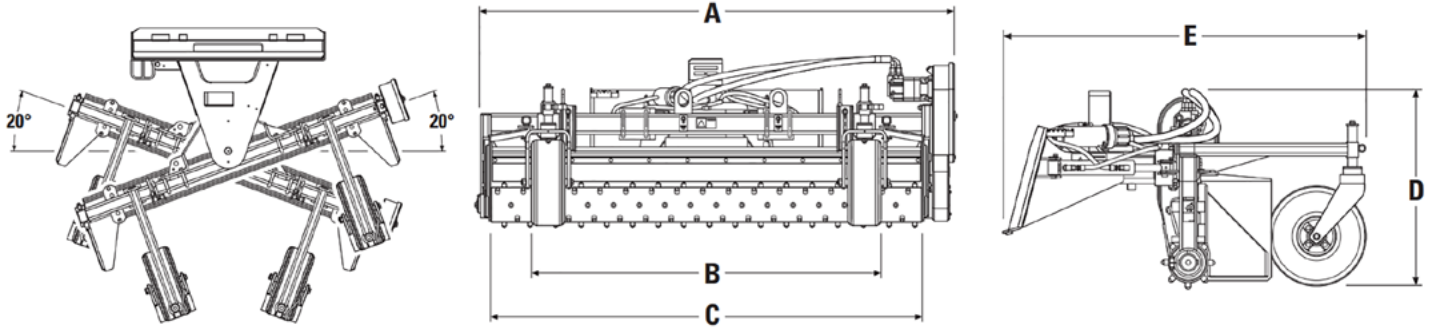

POWER BOX RAKES

Model	PR118	PR121	PR123
A Overall Width – mm (in)	2057 (81)	2362 (93)	2515 (99)
B Width Across Tires – mm (in)	1386 (54.6)	1732 (68.2)	1845 (72.6)
C Roller Width – mm (in)	1829 (72)	2134 (84)	2286 (90)
D Overall Height – mm (in)	847 (33.3)	847 (33.3)	953 (37.5)
E Overall Length – mm (in)	1540 (60.6)	1540 (60.6)	1840 (72.4)
Raking Width at Maximum Angle – mm (in)	1727 (68)	2007 (79)	2159 (85)
Unit Weight (manual) – kg (lb)	408 (900)	465 (1,025)	—
Unit Weight (hydraulic) – kg (lb)	427 (941)	483 (1,065)	606 (1,336)
Maximum Angle, Right or Left	20°	20°	20°
Optimal Hydraulic Flow – L/min (gpm)	49-87 (13-23)	49-87 (13-23)	49-87 (13-23)
Optimal Hydraulic Pressure – bar (psi)	170-241 (2,500-3,500)	170-241 (2,500-3,500)	170-241 (2,500-3,500)



POWER BOX RAKES FOR SKID STEER LOADERS, COMPACT TRACK LOADERS, AND COMPACT WHEEL LOADERS



For more complete information on Cat products, dealer services and industry solutions, visit us on the web at www.cat.com

© 2022 Caterpillar. All Rights Reserved.

Materials and specifications are subject to change without notice. Featured machines in photos may include additional equipment. See your Cat dealer for available options.

CAT, CATERPILLAR, LET'S DO THE WORK, their respective logos, "Caterpillar Corporate Yellow," the "Power Edge" and Cat "Modern Hex" trade dress as well as corporate and product identity used herein, are trademarks of Caterpillar and may not be used without permission.

www.cat.com www.caterpillar.com

AEHQ8407 (03-2022)
Replaces AEHQ5834-03
(Global)

