



966 GC

Wheel Loader

Technical Specifications

Configurations and features may vary by region. Please consult your Cat® dealer for availability in your area.

Table of Contents

Specifications	2
Engine	2
Weights	2
Operating Specifications	2
Bucket Capacities	2
Transmission	2
Service Refill Capacities	2
Air Conditioning System	2
Hydraulic System	3
Tires	3
Sound	3
Cab	3
Brakes	3
Dimensions	4
Tire Options	5
Bucket Fill Factors and Selection Chart	6
Operating Specifications – Buckets	8
Fork Specifications	15
Material Handling Arm Specifications	26
Standard and Optional Equipment	27
966 GC Environmental Declaration	28

966 GC Wheel Loader Specifications

Engine

Engine Model	Cat® C9.3B	
Engine Power @ 2,200 rpm ISO 14396:2002	219 kW	294 hp
ISO 14396:2002 (DIN)	298 hp (metric)	
Gross Power @ 2,200 rpm SAE J1995:2014	223 kW	299 hp
SAE J1995:2014 (DIN)	303 hp (metric)	
Net Power @ 2,200 rpm ISO 9249:2007, SAE J1349:2011	196 kW	263 hp
SAE J1349:2011 (DIN)	266 hp (metric)	
Engine Torque (1,200 rpm) ISO 14396:2002	1781 N·m	1,314 lbf-ft
Gross Torque (1,200 rpm) SAE J1995:2014	1799 N·m	1,327 lbf-ft
Net Torque (1,100 rpm) ISO 3294:2007, SAE J1349:2011, EEC 80/1269	1673 N·m	1,234 lbf-ft
Bore	115 mm	4.5 in
Stroke	149 mm	5.9 in
Displacement	9.30 L	568 in ³

- Cat engine meets U.S. EPA Tier 4 Final, EU Stage V, Korea Stage V, China Nonroad Stage IV and Japan 2014 emission standards.
- The net power advertised is the power available at the flywheel when the engine is equipped with fan, alternator, air cleaner and aftertreatment.
- Cat diesel engines are required to use ULSD (ultra-low sulfur diesel fuel with 15 ppm of sulfur or less) or ULSD blended with the following lower-carbon intensity fuels up to:
 - 20% biodiesel FAME (fatty acid methyl ester)*
 - 100% renewable diesel, HVO (hydrotreated vegetable oil) and GTL (gas-to-liquid) fuels

Refer to guidelines for successful application. Please consult your Cat dealer or “Caterpillar Machine Fluids Recommendations” (SEBU6250) for details.

* Engines with no aftertreatment devices can use higher blends, up to 100% biodiesel.

Weights

Operating Weight	21 781 kg	48,018 lb
------------------	-----------	-----------

- Weight based on a machine configuration with Maxam MS302 L3 Tires, full fluids, operator, standard counterweight, ride control cold start, roading fenders, Product Link™, Open/open axles, power train guard, secondary steering, steering cylinder guard, and a 4.0 m³ (5.25 yd³) general purpose bucket with BOCE.

Operating Specifications

Static Tipping Load Full 37° Turn		
With Tire Deflection	13 640 kg	30,072 lb
Without Tire Deflection	14 621 kg	32,233 lb
Breakout Force	164 kN	36,974 lbf

- For a machine configuration as defined under “Weight.”
- Full compliance to ISO 14397-1:2007 Sections 1 through 6, which requires 2% verification between calculations and testing.

Bucket Capacities

Bucket Range	3.2-7.1 m ³	4.25-9.25 yd ³
--------------	------------------------	---------------------------

Transmission

Forward 1	6.4 km/h	4.0 mph
Forward 2	12.1 km/h	7.5 mph
Forward 3	21.0 km/h	13.0 mph
Forward 4	34.8 km/h	21.6 mph
Reverse 1	7.0 km/h	4.3 mph
Reverse 2	13.2 km/h	8.2 mph
Reverse 3	23.0 km/h	14.3 mph
Reverse 4	36.9 km/h	22.9 mph

- Maximum travel speeds (26.5R25 tires).
- Maximum travel speed in standard vehicle with empty bucket and standard L3 tires with 826 mm (32.5 in) roll radius.

Service Refill Capacities

Fuel Tank Size	320 L	84.5 gal
DEF Tank	26 L	6.9 gal
Cooling System	53 L	14.0 gal
Crankcase	23 L	6.1 gal
Transmission	55 L	14.5 gal
Differentials and Final Drives – Front	57 L	15.1 gal
Differentials and Final Drives – Rear	57 L	15.1 gal
Hydraulic Tank	101 L	26.7 gal

Air Conditioning System

The air conditioning system on this machine contains the fluorinated greenhouse gas refrigerant R134a (Global Warming Potential = 1430). The system contains 1.7 kg (3.7 lb) of refrigerant which has a CO₂ equivalent of 2.431 metric tonnes (2.679 tons).

966 GC Wheel Loader Specifications

Hydraulic System

Implement System Pump Type	Variable displacement piston, load sensing	
Implement System		
Maximum Pump Output at 2,275 rpm	327 L/min	86 gal/min
Maximum Operating Pressure at 50 L/min (13.2 gal/min)	27 900 kPa	4,047 psi
3rd Function Maximum Pressure	22 780 kPa	3,304 psi
3rd Function Maximum Flow	240 L/min	63 gal/min
Hydraulic Cycle Time		
Raise from Carry Position	5.7 seconds	
Dump at Maximum Raise	1.8 seconds	
Lower, Empty, Float Down	2.6 seconds	
Total Cycle Time	10.1 seconds	

Tires*

Choices include:

- Triangle 26.5R25★★ L3 (TB516)
- Triangle 26.5R25★★ L3 (TB598)
- Maxam 26.5R25★★ L3 (MS302)
- Bridgestone 26.5R25★ L3 (VJT)
- Maxam 26.5R25★★ L5 (MS503)
- Bridgestone 26.5R25★ L5 (VSDT)
- Triangle 26.5R25★★ L5 (TL538S+)
- Bridgestone 26.5-25 20PR L-3 (VL2)

*Tire offerings vary by region. Consult your local Cat dealer for further details.

Sound

Operator Sound Pressure Level (ISO 6396:2008)	73 dB(A)
Exterior Sound Power Level (ISO 6395:2008)	110 dB(A)
Operator Sound Pressure Level (ISO 6396:2008)	72 dB(A)*
Exterior Sound Power Level (ISO 6395:2008)	108 dB(A)**

*Including countries that adopt the EU and UK directives.

**EU Noise Directive 2000/14/EC and UK Noise Regulation 2001 No. 1701.

Cab

ROPS/FOPS	ROPS/FOPS meet ISO 3471:2008 and ISO 3449:2005 Level II standards
-----------	---

Brakes

Brakes	Brakes meet ISO 3450:2011 standards
--------	-------------------------------------

966 GC Wheel Loader Specifications

Dimensions

All dimensions are approximate and based on 26.5R25 ★★ L3 TB516 Triangle tires.

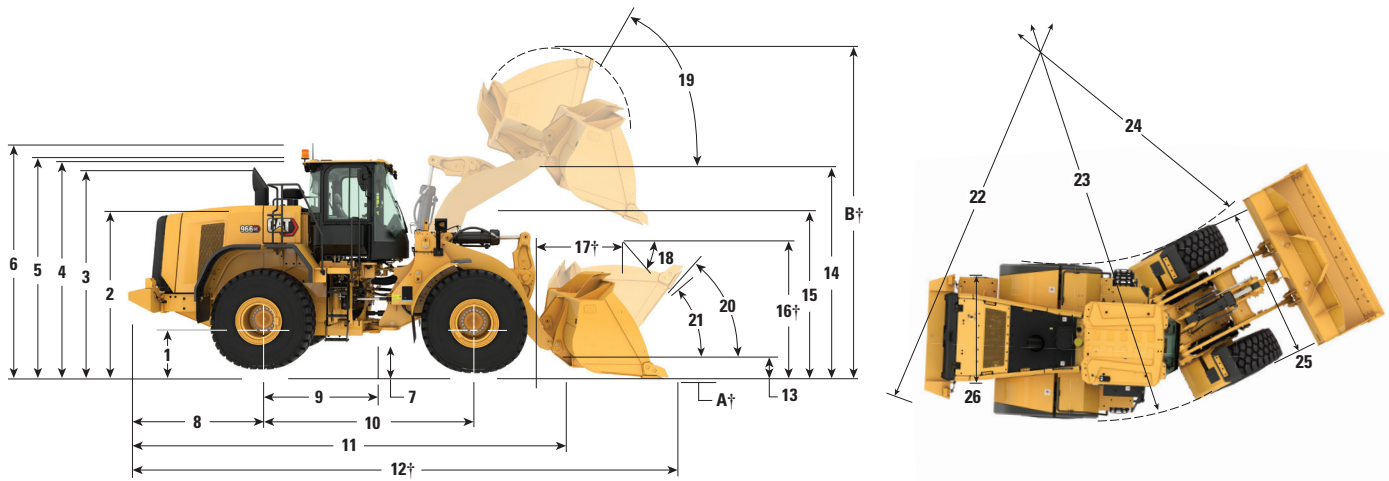

1 Height to Axle Centerline	819 mm	2'7"
2 Height to Top of Hood	2804 mm	9'2"
3 Height to Top of Exhaust Pipe	3539 mm	11'6"
4 Height to Top of ROPS	3582 mm	11'8"
5 Height to Top of Product Link Antenna (EU Stage IIIA/EPA Tier 3)	3612 mm	11'9"
Height to Top of Product Link Antenna (EU Stage V/EPA Tier 4 Final/CNR4)	3583 mm	11'8"
6 Height to Top of Warning Beacon	3877 mm	12'7"
7 Ground Clearance	455 mm	1'5"
8 Center Line of Rear Axle to Edge of Counterweight	2453 mm	8'0"
9 Center Line of Rear Axle to Hitch	1775 mm	5'8"
10 Wheelbase	3550 mm	11'6"
11 Overall Length (without Bucket)	7527 mm	24'7"
12 Shipping Length (with Bucket level on ground)*†	8937 mm	29'3"
13 Hinge Pin Height at Carry Height	614 mm	2'0"
14 Hinge Pin Height at Maximum Lift	4256 mm	14'0"
15 Lift Arm Clearance at Maximum Lift	3705 mm	12'2"
16 Dump Clearance at Maximum Lift and 45° Discharge*†	3064 mm	10'1"
17 Reach at Maximum Lift and 45° Discharge*†	1302 mm	4'3"
18 Dump Angle at Maximum Lift & Dump (on stops)*		45°
19 Rack Back at Maximum Lift*		62°
20 Rack Back at Carry Height*		50°
21 Rack Back at Ground*		42°
22 Clearance Circle (dia) to Counterweight	13 386 mm	44'0"
23 Clearance Circle (dia) to Outside of Tires	13 350 mm	44'0"
24 Clearance Circle (dia) to Inside of Tires	7456 mm	24'5"
25 Width Over Tires (unloaded)	2874 mm	9'4"
Width Over Tires (loaded)	3173 mm	10'4"
26 Tread Width	2230 mm	7'3"

*With 4.0 m³ (5.23 yd³) general purpose pin-on bucket with BOCE (see Operating Specifications for other Buckets).

†Dimensions are listed in Operating Specifications charts.

All height and tire related dimensions are with tire AR-RIM 26.5R25 ** L-3 TB516 Triangle tires (see Tire Option Chart for other tires). "Width Over Tires" dimensions are over the bulge and include growth.

966 GC Wheel Loader Specifications

Tire Options

Tire Brand	Triangle	Maxam	Bridgestone	Maxam
Tire Size	26.5R25	26.5R25	26.5R25	26.5R25
Tread Type	L-3	L-3	L-3	L-5
Tread Pattern	TB516	MS302	VJT	MS503
Width over Tires – Maximum (empty)*	2874 mm 9'5"	2965 mm 9'9"	2966 mm 9'9"	2955 mm 9'8"
Width over Tires – Maximum (loaded)*	3173 mm 10'5"	3007 mm 9'10"	3005 mm 9'10"	3000 mm 9'10"
Change in Vertical Dimensions (average of front and rear)		7 mm 0.3"	-2 mm -0.1"	33 mm 1.3"
Change in Horizontal Reach		-0.5 mm -0.02"	6.5 mm 0.26"	-22 mm -0.87"
Change in Clearance Circle to Outside of Tires		-83 mm -3.27"	-84 mm -3.31"	-86.5 mm -3.41"
Change in Clearance Circle to Inside of Tires		83 mm 3.27"	84 mm 3.31"	86.5 mm 3.41"
Change in Operating Weight (without Ballast)		-64 kg -141.1 lb	-180 kg -396.8 lb	652 kg 1,437 lb
Rear Axle Oscillation Angle	±13 degrees	±13 degrees	±13 degrees	±8 degrees
Maximum Single-wheel Rise and Fall	502 mm 1'8"	502 mm 1'8"	502 mm 1'8"	310 mm 1'1"

*Width over tire bulge and includes tire growth.

Tire Brand	Bridgestone	Triangle	Triangle	Bridgestone
Tire Size	26.5R25	26.5R25	26.5R25	26.5-25
Tread Type	L-5	L-5	L-3	L-3
Tread Pattern	VSDT	TL538S+	TB598	VL2
Width over Tires – Maximum (empty)*	2972 mm 9'9"	2962 mm 9'9"	2943 mm 9'8"	2927 mm 9'7"
Width over Tires – Maximum (loaded)*	2995 mm 9'10"	2980 mm 9'9"	2999 mm 9'10"	2946 mm 9'8"
Change in Vertical Dimensions (average of front and rear)	26.5 mm 1.0"	8.5 mm 0.3"	-28.5 mm -1.1"	-45 mm -1.8"
Change in Horizontal Reach	-12.5 mm -0.49"	-29 mm -1.14"	3 mm 0.12"	6 mm 0.24"
Change in Clearance Circle to Outside of Tires	-89 mm -3.5"	-96.5 mm -3.8"	-87 mm -3.43"	-113.5 mm -4.47"
Change in Clearance Circle to Inside of Tires	89 mm 3.5"	96.5 mm 3.8"	87 mm 3.43"	113.5 mm 4.47"
Change in Operating Weight (without Ballast)	764 kg 1,684 lb	656 kg 1,446 lb	-80 kg -176.4 lb	-404 kg -890.7 lb
Rear Axle Oscillation Angle	±8 degrees	±8 degrees	±13 degrees	±13 degrees
Maximum Single-wheel Rise and Fall	310 mm 1'1"	310 mm 1'1"	502 mm 1'8"	502 mm 1'8"

*Width over tire bulge and includes tire growth.

966 GC Wheel Loader Specifications

Bucket Fill Factors and Selection Guide

The bucket size must be chosen based on the density of the material and on the expected fill factor. The Cat Performance Series Buckets with longer floor, larger bucket opening, increased repository angle, rounded side boards and integrated spill guard demonstrate fill factors significantly higher than previous generation or non-Cat buckets. The actual volume handled by the machine is thus often larger than the rated capacity.

Loose Material		Fill Factor (%)*	Material Density
Earth/Clay		115	1.5-1.7
Sand and Gravel		115	1.5-1.7
Aggregate:	25-76 mm (1 to 3 in)	110	1.6-1.7
	19 mm (0.75 in) and smaller	105	1.8
Rock:	76 mm (3 in) and larger	100	1.6

*As a % of ISO 7546 rated capacity.

Note: Fill Factors achieved will also depend on whether the product is washed or not washed.

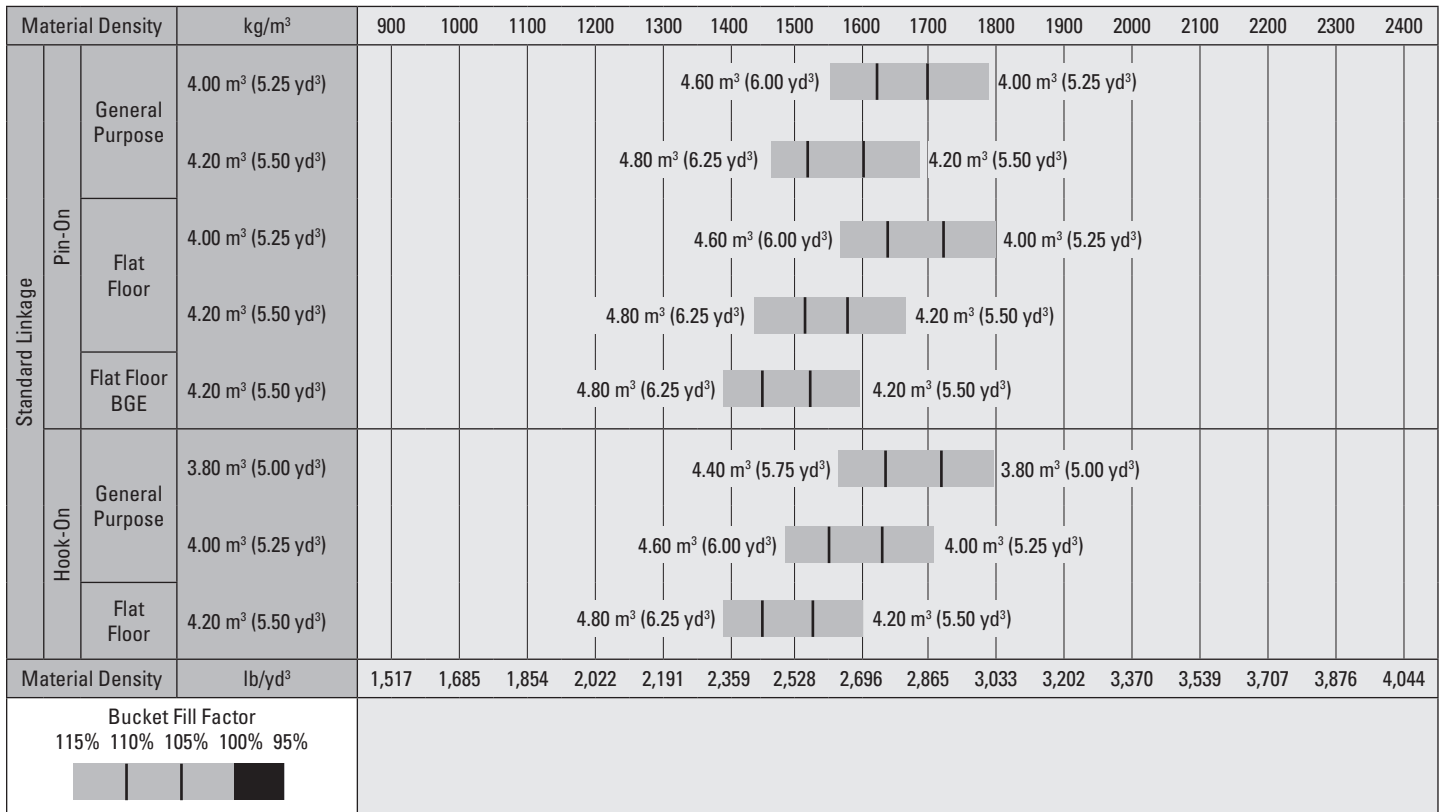

Note: All buckets are showing Bolt-On Edges.

*Bucket availability may vary by region.

966 GC Wheel Loader Specifications

Bucket Fill Factors and Selection Guide

The bucket size must be chosen based on the density of the material and on the expected fill factor. The Cat Performance Series Buckets with longer floor, larger bucket opening, increased repository angle, rounded side boards and integrated spill guard demonstrate fill factors significantly higher than previous generation or non-Cat buckets. The actual volume handled by the machine is thus often larger than the rated capacity.

Loose Material		Fill Factor (%)*	Material Density
Earth/Clay		115	1.5-1.7
Sand and Gravel		115	1.5-1.7
Aggregate:	25-76 mm (1 to 3 in)	110	1.6-1.7
	19 mm (0.75 in) and smaller	105	1.8
Rock:	76 mm (3 in) and larger	100	1.6

*As a % of ISO 7546 rated capacity.

Note: Fill Factors achieved will also depend on whether the product is washed or not washed.

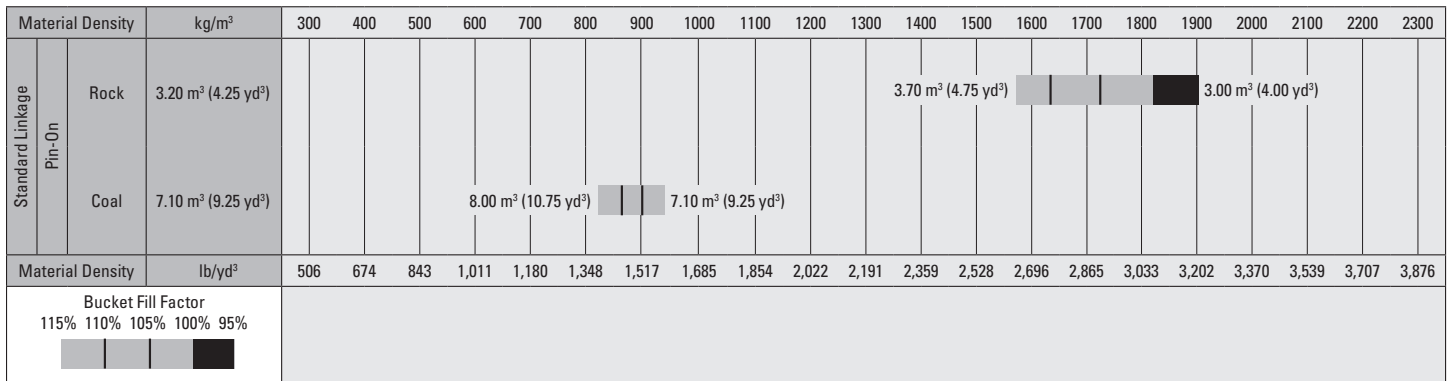

Note: All buckets are showing Bolt-On Edges.

*Bucket availability may vary by region.

** Data with Rock, Spade buckets equipped with Teeth and Segments and machine with L5 tires.

966 GC Wheel Loader Specifications

Operating Specifications – Buckets

Linkage		Standard Linkage						
Bucket Type		General Purpose – Pin-On						
Edge Type		Bolt-On Cutting Edges	Teeth and Segments	Tips	Bolt-On Cutting Edges	Teeth and Segments	Tips	
Capacity – Rated	m ³	4.00	4.00	3.85	4.20	4.20	4.00	
	yd ³	5.25	5.25	5.00	5.50	5.50	5.25	
Capacity – Rated at 110% Fill Factor	m ³	4.40	4.40	4.20	4.60	4.60	4.50	
	yd ³	5.75	5.75	5.50	6.00	6.00	6.00	
Width	mm	3220	3271	3271	3220	3271	3271	
	ft/in	10'6"	10'8"	10'8"	10'6"	10'8"	10'8"	
16 † Dump Clearance at Maximum Lift and 45° Discharge	mm	3071	2918	2918	3042	2888	2888	
	ft/in	10'0"	9'6"	9'6"	9'11"	9'5"	9'5"	
17 † Reach at Maximum Lift and 45° Discharge	mm	1300	1439	1439	1324	1462	1462	
	ft/in	4'3"	4'8"	4'8"	4'4"	4'9"	4'9"	
Reach at Level Lift Arm and Bucket Level	mm	2724	2928	2928	2762	2966	2966	
	ft/in	8'11"	9'7"	9'7"	9'0"	9'8"	9'8"	
A † Digging Depth	mm	97	97	67	97	97	67	
	in	3.8"	3.8"	2.6"	3.8"	3.8"	2.6"	
12 † Overall Length	mm	8932	9157	9157	8970	9195	9195	
	ft/in	29'4"	30'1"	30'1"	29'6"	30'3"	30'3"	
B † Overall Height with Bucket at Maximum Lift	mm	5856	5856	5856	5895	5895	5895	
	ft/in	19'3"	19'3"	19'3"	19'5"	19'5"	19'5"	
Loader Clearance Circle Radius with Bucket at Carry Position	mm	7501	7587	7587	7510	7597	7597	
	ft/in	24'8"	24'11"	24'11"	24'8"	25'0"	25'0"	
Static Tipping Load, Straight (With tire deflection)	kg	15 488	15 304	15 510	15 421	15 237	15 435	
	lb	34,136	33,731	34,184	33,989	33,582	34,018	
Static Tipping Load, Straight (No tire deflection)	kg	16 464	16 279	16 485	16 403	16 216	16 414	
	lb	36,288	35,879	36,334	36,152	35,740	36,177	
Static Tipping Load, Articulated (With tire deflection)	kg	13 640	13 456	13 650	13 575	13 391	13 577	
	lb	30,063	29,658	30,085	29,920	29,513	29,925	
Static Tipping Load, Articulated (No tire deflection)	kg	14 620	14 434	14 629	14 560	14 373	14 560	
	lb	32,223	31,814	32,242	32,091	31,680	32,090	
Breakout Force (§)	kN	164	162	174	159	157	169	
	lbf	36,927	36,575	39,295	35,828	35,477	38,060	
Operating Weight*	kg	21 781	21 919	21 756	21 822	21 960	21 797	
	lb	48,006	48,309	47,950	48,096	48,400	48,040	

* Static tipping loads and operating weights shown are based on a machine configuration with standard ambient cooling, open differentials axles, Triangle 26.5R25 L3★ TB516 tires, standard counterweight, full fluids, and 75 kg (165 lb) operator.

† Illustration shown with Dimension charts.

(§) Measured 100 mm (4") behind tip of cutting edge with bucket hinge pin as pivot point in accordance with ISO 14397-2:2007.

(With tire deflection) Full compliance to ISO 14397-1:2007 Sections 1 thru 6, which requires 2% verification between calculations and testing.

(No tire deflection) Compliance to ISO 14397-1:2007 Sections 1 thru 5.

Bucket and work tool offerings vary by region. Consult your local Cat dealer for further details.

966 GC Wheel Loader Specifications

Operating Specifications – Buckets

Linkage		Standard Linkage					
Bucket Type		General Purpose – Pin-On					
Edge Type		Bolt-On Cutting Edges	Teeth and Segments	Tips	Bolt-On Cutting Edges	Teeth and Segments	Tips
Capacity – Rated	m ³	4.00	4.00	3.80	4.20	4.20	4.00
	yd ³	5.25	5.25	5.00	5.50	5.50	5.25
Capacity – Rated at 110% Fill Factor	m ³	4.40	4.40	4.20	4.60	4.60	4.40
	yd ³	5.75	5.75	5.50	6.00	6.00	5.75
Width	mm	3220	3301	3271	3220	3301	3271
	ft/in	10'6"	10'9"	10'8"	10'6"	10'9"	10'8"
16† Dump Clearance at Maximum Lift and 45° Discharge	mm	3085	2909	2932	3018	2849	2864
	ft/in	10'1"	9'6"	9'7"	9'10"	9'4"	9'4"
17† Reach at Maximum Lift and 45° Discharge	mm	1289	1420	1428	1343	1480	1480
	ft/in	4'2"	4'7"	4'8"	4'4"	4'10"	4'10"
Reach at Level Lift Arm and Bucket Level	mm	2705	2919	2910	2793	3008	2998
	ft/in	8'10"	9'6"	9'6"	9'1"	9'10"	9'10"
A† Digging Depth	mm	97	97	67	97	97	67
	in	3.8"	3.8"	2.6"	3.8"	3.8"	2.6"
12† Overall Length	mm	8914	9167	9139	9001	9245	9227
	ft/in	29'3"	30'1"	30'0"	29'7"	30'4"	30'4"
B† Overall Height with Bucket at Maximum Lift	mm	5915	5915	5915	5915	5915	5915
	ft/in	19'5"	19'5"	19'5"	19'5"	19'5"	19'5"
Loader Clearance Circle Radius with Bucket at Carry Position	mm	7489	7599	7575	7511	7617	7597
	ft/in	24'7"	25'0"	24'11"	24'8"	25'0"	25'0"
Static Tipping Load, Straight (With tire deflection)	kg	15 366	15 128	15 404	15 176	14 971	15 220
	lb	33,868	33,344	33,951	33,449	32,996	33,546
Static Tipping Load, Straight (No tire deflection)	kg	16 353	16 112	16 391	16 156	15 947	16 200
	lb	36,043	35,511	36,126	35,608	35,149	35,705
Static Tipping Load, Articulated (With tire deflection)	kg	13 510	13 271	13 534	13 333	13 127	13 362
	lb	29,776	29,251	29,829	29,386	28,932	29,451
Static Tipping Load, Articulated (No tire deflection)	kg	14 500	14 258	14 522	14 316	14 107	14 344
	lb	31,959	31,425	32,008	31,553	31,093	31,616
Breakout Force (§)	kN	166	163	176	155	153	164
	lbf	37,318	36,764	39,744	34,872	34,412	36,996
Operating Weight*	kg	21 974	22 145	21 949	22 030	22 175	22 005
	lb	48,431	48,807	48,375	48,554	48,873	48,499

*Static tipping loads and operating weights shown are based on a machine configuration with standard ambient cooling, open differentials axles, Triangle 26.5R25 L3★ TB516 tires, standard counterweight, full fluids, and 75 kg (165 lb) operator.

† Illustration shown with Dimension charts.

(§) Measured 100 mm (4") behind tip of cutting edge with bucket hinge pin as pivot point in accordance with ISO 14397-2:2007.

(With tire deflection) Full compliance to ISO 14397-1:2007 Sections 1 thru 6, which requires 2% verification between calculations and testing.

(No tire deflection) Compliance to ISO 14397-1:2007 Sections 1 thru 5.

Bucket and work tool offerings vary by region. Consult your local Cat dealer for further details.

966 GC Wheel Loader Specifications

Operating Specifications – Buckets

Linkage		Standard Linkage					
Bucket Type		General Purpose – Hook-On – Fusion™					
Edge Type		Bolt-On Cutting Edges	Teeth and Segments	Tips	Bolt-On Cutting Edges	Teeth and Segments	Tips
Capacity – Rated	m ³	3.80	3.80	3.60	4.00	4.00	3.80
	yd ³	5.00	5.00	4.75	5.25	5.25	5.00
Capacity – Rated at 110% Fill Factor	m ³	4.20	4.20	4.00	4.40	4.40	4.20
	yd ³	5.50	5.50	5.25	5.75	5.75	5.50
Width	mm	3220	3271	3271	3201	3201	3201
	ft/in	10'6"	10'8"	10'8"	10'6"	10'6"	10'6"
16† Dump Clearance at Maximum Lift and 45° Discharge	mm	3065	2913	2913	3052	2897	2897
	ft/in	10'0"	9'6"	9'6"	10'0"	9'6"	9'6"
17† Reach at Maximum Lift and 45° Discharge	mm	1317	1456	1456	1320	1461	1461
	ft/in	4'3"	4'9"	4'9"	4'3"	4'9"	4'9"
Reach at Level Lift Arm and Bucket Level	mm	2738	2943	2943	2750	2958	2958
	ft/in	8'11"	9'7"	9'7"	9'0"	9'8"	9'8"
A† Digging Depth	mm	97	97	67	67	67	67
	in	3.8"	3.8"	2.6"	2.6"	2.6"	2.6"
12† Overall Length	mm	8947	9172	9172	8962	9191	9191
	ft/in	29'5"	30'2"	30'2"	29'5"	30'2"	30'2"
B† Overall Height with Bucket at Maximum Lift	mm	5830	5830	5830	5946	5946	5946
	ft/in	19'2"	19'2"	19'2"	19'7"	19'7"	19'7"
Loader Clearance Circle Radius with Bucket at Carry Position	mm	7511	7600	7600	7506	7574	7574
	ft/in	24'8"	25'0"	25'0"	24'8"	24'11"	24'11"
Static Tipping Load, Straight (With tire deflection)	kg	14 828	14 646	14 979	14 781	14 566	14 913
	lb	32,681	32,280	33,014	32,578	32,104	32,869
Static Tipping Load, Straight (No tire deflection)	kg	15 786	15 602	15 947	15 750	15 532	15 893
	lb	34,793	34,386	35,147	34,713	34,232	35,030
Static Tipping Load, Articulated (With tire deflection)	kg	12 998	12 816	13 135	12 951	12 736	13 068
	lb	28,649	28,247	28,950	28,546	28,071	28,802
Static Tipping Load, Articulated (No tire deflection)	kg	13 960	13 776	14 107	13 924	13 706	14 052
	lb	30,770	30,363	31,092	30,689	30,209	30,970
Breakout Force (§)	kN	161	160	172	170	168	169
	lbf	36,358	36,007	38,663	38,209	37,771	38,137
Operating Weight*	kg	22 337	22 475	22 312	22 385	22 547	22 381
	lb	49,231	49,535	49,175	49,336	49,693	49,327

*Static tipping loads and operating weights shown are based on a machine configuration with standard ambient cooling, open differentials axles, Triangle 26.5R25 L3★ TB516 tires, standard counterweight, full fluids, and 75 kg (165 lb) operator.

† Illustration shown with Dimension charts.

(§) Measured 100 mm (4") behind tip of cutting edge with bucket hinge pin as pivot point in accordance with ISO 14397-2:2007.

(With tire deflection) Full compliance to ISO 14397-1:2007 Sections 1 thru 6, which requires 2% verification between calculations and testing.

(No tire deflection) Compliance to ISO 14397-1:2007 Sections 1 thru 5.

Bucket and work tool offerings vary by region. Consult your local Cat dealer for further details.

966 GC Wheel Loader Specifications

Operating Specifications – Buckets

Linkage		Standard Linkage					
		Flat Floor – Pin-On					
Bucket Type		GC Flat Floor	Flat Floor – BGE – Abrasion	GC Flat Floor	Flat Floor – Abrasion	Flat Floor – BGE – Abrasion	Flat Floor – BGE – Abrasion
Edge Type		Bolt-On Cutting Edges	FMT	Bolt-On Cutting Edges	Bolt-On Cutting Edges	Bolt-On Cutting Edges	FMT
Capacity – Rated	m ³	4.00	4.00	4.20	4.20	4.20	4.20
	yd ³	5.25	5.25	5.50	5.50	5.50	5.50
Capacity – Rated at 110% Fill Factor	m ³	4.40	4.40	4.60	4.60	4.60	4.60
	yd ³	5.75	5.75	6.00	6.00	6.00	6.00
Width	mm	2994	2994	2995	2995	2995	2996
	ft/in	9'9"	9'9"	9'9"	9'9"	9'9"	9'9"
16 † Dump Clearance at Maximum Lift and 45° Discharge	mm	2947	2786	2921	2929	2921	2723
	ft/in	9'8"	9'1"	9'7"	9'7"	9'7"	8'11"
17 † Reach at Maximum Lift and 45° Discharge	mm	1258	1456	1291	1283	1291	1522
	ft/in	4'1"	4'9"	4'2"	4'2"	4'2"	4'11"
Reach at Level Lift Arm and Bucket Level	mm	2801	3054	2842	2831	2842	3146
	ft/in	9'2"	10'0"	9'3"	9'3"	9'3"	10'3"
A † Digging Depth	mm	102	67	97	97	97	72
	in	4.0"	2.6"	3.8"	3.8"	3.8"	2.8"
12 † Overall Length	mm	9013	9245	9050	9039	9050	9335
	ft/in	29'7"	30'4"	29'9"	29'8"	29'9"	30'8"
B † Overall Height with Bucket at Maximum Lift	mm	5727	5771	6001	6041	6003	6075
	ft/in	18'10"	19'0"	19'9"	19'10"	19'9"	20'0"
Loader Clearance Circle Radius with Bucket at Carry Position	mm	7419	7477	7419	7416	7419	7492
	ft/in	24'5"	24'7"	24'5"	24'4"	24'5"	24'7"
Static Tipping Load, Straight (With tire deflection)	kg	15 496	15 532	14 994	14 873	14 546	14 466
	lb	34,154	34,234	33,048	32,780	32,061	31,884
Static Tipping Load, Straight (No tire deflection)	kg	16 460	16 511	15 954	15 836	15 498	15 433
	lb	36,278	36,390	35,162	34,903	34,159	34,015
Static Tipping Load, Articulated (With tire deflection)	kg	13 667	13 690	13 176	13 052	12 728	12 640
	lb	30,122	30,174	29,041	28,766	28,054	27,859
Static Tipping Load, Articulated (No tire deflection)	kg	14 635	14 672	14 140	14 019	13 685	13 611
	lb	32,255	32,339	31,166	30,899	30,162	29,999
Breakout Force (§)	kN	155	161	149	150	148	147
	lbf	34,990	36,215	33,659	33,770	33,333	33,050
Operating Weight*	kg	21 577	21 649	22 013	22 167	22 413	22 536
	lb	47,555	47,714	48,516	48,856	49,398	49,669

*Static tipping loads and operating weights shown are based on a machine configuration with standard ambient cooling, open differentials axles, Triangle 26.5R25 L3 ★ TB516 tires, standard counterweight, full fluids, and 75 kg (165 lb) operator.

† Illustration shown with Dimension charts.

(§) Measured 100 mm (4") behind tip of cutting edge with bucket hinge pin as pivot point in accordance with ISO 14397-2:2007.

(With tire deflection) Full compliance to ISO 14397-1:2007 Sections 1 thru 6, which requires 2% verification between calculations and testing.

(No tire deflection) Compliance to ISO 14397-1:2007 Sections 1 thru 5.

Bucket and work tool offerings vary by region. Consult your local Cat dealer for further details.

966 GC Wheel Loader Specifications

Operating Specifications – Buckets

Linkage		Standard Linkage	
Bucket Type		Flat Floor – Hook-On – Fusion	Flat Floor – Hook-On – Fusion – BGE
Edge Type		Bolt-On Cutting Edges	FMT
Capacity – Rated	m ³	4.20	4.20
	yd ³	5.50	5.50
Capacity – Rated at 110% Fill Factor	m ³	4.60	4.60
	yd ³	6.00	6.00
Width	mm	2995	2996
	ft/in	9'9"	9'9"
16 † Dump Clearance at Maximum Lift and 45° Discharge	mm	2879	4313
	ft/in	9'5"	14'1"
17 † Reach at Maximum Lift and 45° Discharge	mm	1333	2409
	ft/in	4'4"	7'10"
Reach at Level Lift Arm and Bucket Level	mm	2902	3244
	ft/in	9'6"	10'7"
A † Digging Depth	mm	97	76
	in	3.8"	3.0"
12 † Overall Length	mm	9110	9495
	ft/in	29'11"	31'2"
B † Overall Height with Bucket at Maximum Lift	mm	6029	6116
	ft/in	19'10"	20'1"
Loader Clearance Circle Radius with Bucket at Carry Position	mm	7453	7533
	ft/in	24'6"	24'9"
Static Tipping Load, Straight (With tire deflection)	kg	14 117	15 151
	lb	31,123	33,394
Static Tipping Load, Straight (No tire deflection)	kg	15 062	16 173
	lb	33,206	35,645
Static Tipping Load, Articulated (With tire deflection)	kg	12 324	13 297
	lb	27,170	29,306
Static Tipping Load, Articulated (No tire deflection)	kg	13 274	14 320
	lb	29,265	31,562
Breakout Force (§)	kN	141	143
	lbf	31,874	32,331
Operating Weight*	kg	22 729	22 188
	lb	50,109	48,902

*Static tipping loads and operating weights shown are based on a machine configuration with standard ambient cooling, open differentials axles, Triangle 26.5R25 L3 ★ TB516 tires, standard counterweight, full fluids, and 75 kg (165 lb) operator.

† Illustration shown with Dimension charts.

(§) Measured 100 mm (4") behind tip of cutting edge with bucket hinge pin as pivot point in accordance with ISO 14397-2:2007.

(With tire deflection) Full compliance to ISO 14397-1:2007 Sections 1 thru 6, which requires 2% verification between calculations and testing.

(No tire deflection) Compliance to ISO 14397-1:2007 Sections 1 thru 5.

Bucket and work tool offerings vary by region. Consult your local Cat dealer for further details.

Operating Specifications – Buckets

Linkage		Standard Linkage		
Bucket Type		Rock – Pin-On		
Edge Type		Bolt-On Cutting Edges	Teeth and Segments	Tips
Capacity – Rated	m ³	3.20	3.20	3.00
	yd ³	4.25	4.25	4.00
Capacity – Rated at 110% Fill Factor	m ³	3.50	3.50	3.30
	yd ³	4.50	4.50	4.25
Width	mm	3252	3252	3252
	ft/in	10'8"	10'8"	10'8"
16† Dump Clearance at Maximum Lift and 45° Discharge	mm	3126	3022	3022
	ft/in	10'3"	9'10"	9'10"
17† Reach at Maximum Lift and 45° Discharge	mm	1435	1535	1535
	ft/in	4'8"	5'0"	5'0"
Reach at Level Lift Arm and Bucket Level	mm	2779	2921	2921
	ft/in	9'1"	9'7"	9'7"
A† Digging Depth	mm	78	78	78
	in	3.0"	3.0"	3.0"
12† Overall Length	mm	8996	9160	9160
	ft/in	29'7"	30'1"	30'1"
B† Overall Height with Bucket at Maximum Lift	mm	5896	5896	5896
	ft/in	19'5"	19'5"	19'5"
Loader Clearance Circle Radius with Bucket at Carry Position	mm	7529	7576	7576
	ft/in	24'9"	24'11"	24'11"
Static Tipping Load, Straight (With tire deflection)	kg	15 717	15 567	15 975
	lb	34,641	34,311	35,210
Static Tipping Load, Straight (No tire deflection)	kg	16 723	16 571	16 992
	lb	36,857	36,523	37,451
Static Tipping Load, Articulated (With tire deflection)	kg	13 800	13 649	14 045
	lb	30,415	30,084	30,955
Static Tipping Load, Articulated (No tire deflection)	kg	14 809	14 658	15 065
	lb	32,641	32,306	33,204
Breakout Force (§)	kN	174	173	175
	lbf	39,309	39,019	39,465
Operating Weight*	kg	22 888	22 999	22 768
	lb	50,445	50,690	50,180

*Static tipping loads and operating weights shown are based on a machine configuration with standard ambient cooling, open differentials axles, Triangle 26.5R25 L3★ TB516 tires, standard counterweight, full fluids, and 75 kg (165 lb) operator.

† Illustration shown with Dimension charts.

(§) Measured 100 mm (4") behind tip of cutting edge with bucket hinge pin as pivot point in accordance with ISO 14397-2:2007.

(With tire deflection) Full compliance to ISO 14397-1:2007 Sections 1 thru 6, which requires 2% verification between calculations and testing.

(No tire deflection) Compliance to ISO 14397-1:2007 Sections 1 thru 5.

Bucket and work tool offerings vary by region. Consult your local Cat dealer for further details.

966 GC Wheel Loader Specifications

Operating Specifications – Buckets

Linkage		Standard Linkage
Bucket Type		Coal – Pin-On
Edge Type		Bolt-On Cutting Edges
Capacity – Rated	m ³	7.10
	yd ³	9.25
Capacity – Rated at 110% Fill Factor	m ³	7.80
	yd ³	10.25
Width	mm	3447
	ft/in	11'3"
16 † Dump Clearance at Maximum Lift and 45° Discharge	mm	2652
	ft/in	8'8"
17 † Reach at Maximum Lift and 45° Discharge	mm	1538
	ft/in	5'0"
Reach at Level Lift Arm and Bucket Level	mm	3207
	ft/in	10'6"
A † Digging Depth	mm	113
	in	4.4"
12 † Overall Length	mm	9428
	ft/in	31'0"
B † Overall Height with Bucket at Maximum Lift	mm	6098
	ft/in	20'1"
Loader Clearance Circle Radius with Bucket at Carry Position	mm	7727
	ft/in	25'5"
Static Tipping Load, Straight (With tire deflection)	kg	14 494
	lb	31,945
Static Tipping Load, Straight (No tire deflection)	kg	15 508
	lb	34,180
Static Tipping Load, Articulated (With tire deflection)	kg	12 673
	lb	27,932
Static Tipping Load, Articulated (No tire deflection)	kg	13 690
	lb	30,174
Breakout Force (§)	kN	115
	lbf	25,910
Operating Weight*	kg	22 338
	lb	49,233

*Static tipping loads and operating weights shown are based on a machine configuration with standard ambient cooling, open differentials axles, Triangle 26.5R25 L3 ★ TB516 tires, standard counterweight, full fluids, and 75 kg (165 lb) operator.

† Illustration shown with Dimension charts.

(§) Measured 100 mm (4") behind tip of cutting edge with bucket hinge pin as pivot point in accordance with ISO 14397-2:2007.

(With tire deflection) Full compliance to ISO 14397-1:2007 Sections 1 thru 6, which requires 2% verification between calculations and testing.

(No tire deflection) Compliance to ISO 14397-1:2007 Sections 1 thru 5.

Bucket and work tool offerings vary by region. Consult your local Cat dealer for further details.

966 GC Wheel Loader Specifications

Fork Specifications

Fork Specifications

1	Tine Length	mm	1524
		in	60.0
2	Load Center	mm	762
		in	30.0
	Static Tipping Load - Straight (Forks Level)	kg	11169
		lbs	24617
	Static Tipping Load - Articulated (Forks Level)	kg	9905
		lbs	21830
	Rated Load (SAE J1197 - 50% FTSTL)	kg	4952
		lbs	10915
	Rated Load (CEN EN 474-3 Rough Terrain - 60% FTSTL)	kg	5943
		lbs	13098
	Rated Load (CEN EN 474-3 Firm and Level Ground - 80% FTSTL)	kg	7761
		lbs	17105
3	Maximum Overall Length	mm	9509
		in	374.4
4	Reach with Forks at Ground Level	mm	1106
		in	43.6
5	*Ground to Bottom of Tine at Minimum Height and Fork Level	mm	-149
		in	-5.9
6	Reach with Arms Horizontal and Forks Level	mm	1687
		in	66.4
7	Reach with Fork at Maximum Height	mm	819
		in	32.3
8	Ground to Top of Tine with Arms Horizontal and Fork Level	mm	1883
		in	74.1
9	Ground to Top of Tine at Maximum Height and Fork Level	mm	3966
		in	156.1
10	Overall Height of Fork at Full Lift (top of carriage to ground)	mm	4741
		in	186.7
11	Clearance at Full Lift and Max Dump	mm	2669
		in	105.1
12	Max Discharge Angle from Horizontal	deg	43
13	Overall Carriage Width	mm	2217
		in	87.3
14	Overall Carriage Height	mm	840
		in	33.1
15	Outside Tine Width (max spread)	mm	2070
		in	81.5
16	Outside Tine Width (min spread)	mm	470
		in	18.5
	Tine Width (single tine)	mm	150.0
		in	5.9
	Tine Thickness	mm	65.0
		in	2.6
	Tine Capacity	kg	6300
		lbs	13885
	Operating Weight	kg	21059
		lbs	46413

*Negative values indicate below grade

966 GC S5 Pallet Fork, FUSION

87" Carriage
530-1861

60" Tine
548-3265

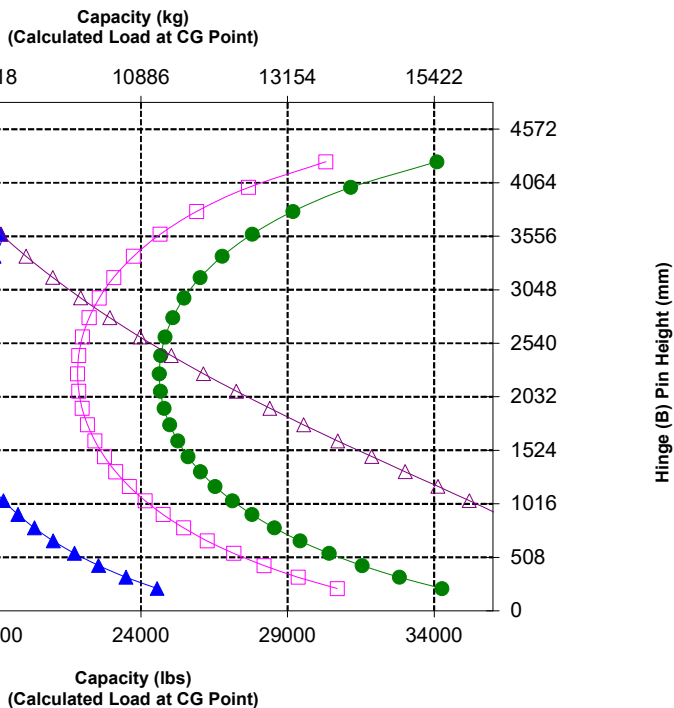
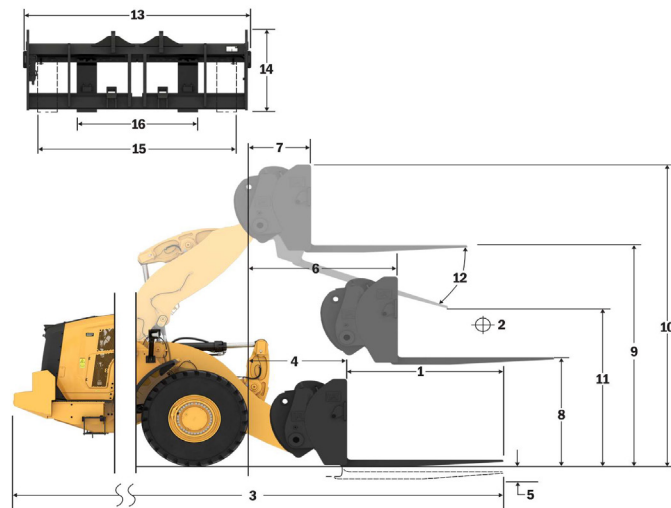

NOTE: Static tipping loads and operating weight are based on the following loader configuration: Maxam MS302 L3 Tires, Air Conditioning, Ride Control, Powertrain Guard, Full Fluids, Fuel Tank, Coolant, Lubricants, and Operator.

Specifications and ratings conform to the following standards: SAE* J1197, SAE J732, CEN** EN 474-3.

The rated operating load for a loader equipped with a pallet fork is determined by:
SAE J1197: 50% of full turn static tipping load or hydraulic limit.
CEN EN 474-3: 60% of full turn static tipping load on rough terrain or hydraulic limit.
CEN EN 474-3: 80% of full turn static tipping load on firm and level ground or hydraulic limit.

*SAE - Society of Automotive Engineers

**CEN - European Committee for Standardization



WARNING: Do not exceed tine load capacity. Individual tine capacity is stamped on the side of each tine.

966 GC Wheel Loader Specifications

Fork Specifications

Fork Specifications

1	Tine Length	mm	1830
		in	72.0
2	Load Center	mm	915
		in	36.0
	Static Tipping Load - Straight (Forks Level)	kg	10638
		lbs	23445
	Static Tipping Load - Articulated (Forks Level)	kg	9428
		lbs	20779
	Rated Load (SAE J1197 - 50% FTSTL)	kg	4714
		lbs	10390
	Rated Load (CEN EN 474-3 Rough Terrain - 60% FTSTL)	kg	5657
		lbs	12468
	Rated Load (CEN EN 474-3 Firm and Level Ground - 80% FTSTL)	kg	6825
		lbs	15041
3	Maximum Overall Length	mm	9815
		in	386.4
4	Reach with Forks at Ground Level	mm	1106
		in	43.6
5	*Ground to Bottom of Tine at Minimum Height and Fork Level	mm	-149
		in	-5.9
6	Reach with Arms Horizontal and Forks Level	mm	1687
		in	66.4
7	Reach with Fork at Maximum Height	mm	819
		in	32.3
8	Ground to Top of Tine with Arms Horizontal and Fork Level	mm	1883
		in	74.1
9	Ground to Top of Tine at Maximum Height and Fork Level	mm	4741
		in	186.7
10	Overall Height of Fork at Full Lift (top of carriage to ground)	mm	2461
		in	96.9
11	Clearance at Full Lift and Max Dump	mm	2217
		in	87.3
12	Max Discharge Angle from Horizontal	deg	43
13	Overall Carriage Width	mm	840
		in	33.1
14	Overall Carriage Height	mm	2070
		in	81.5
15	Outside Tine Width (max spread)	mm	470
		in	18.5
16	Outside Tine Width (min spread)	mm	150.0
		in	5.9
	Tine Thickness	mm	65.0
		in	2.6
	Tine Capacity	kg	5246
		lbs	11562
	Operating Weight	kg	21106
		lbs	46517

*Negative values indicate below grade

966 GC S5 Pallet Fork, FUSION

87" Carriage 72" Tine
530-1861 530-1869

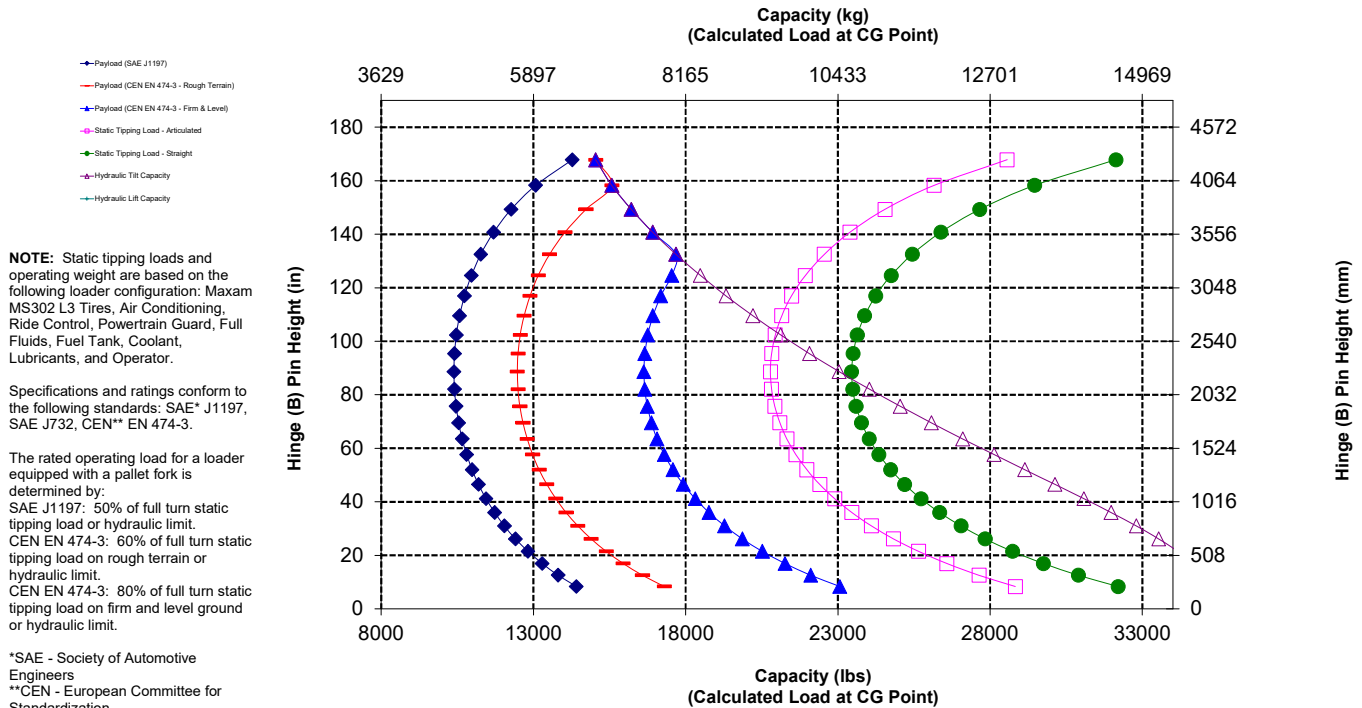
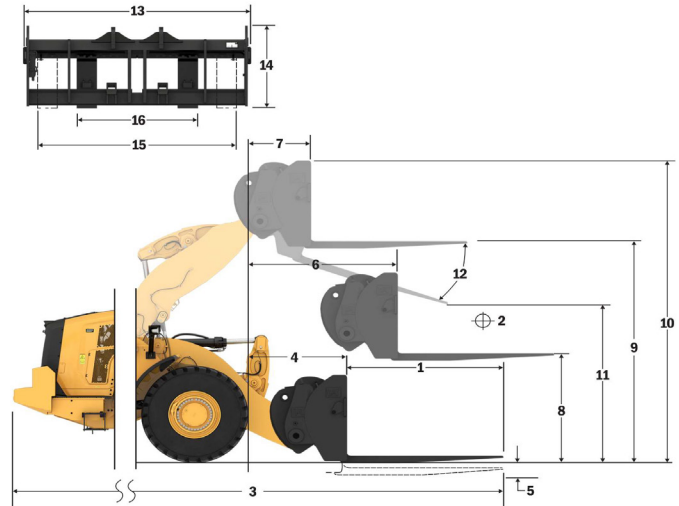

WARNING: Do not exceed tine load capacity. Individual tine capacity is stamped on the side of each tine.

966 GC Wheel Loader Specifications

Fork Specifications

Fork Specifications

1	Tine Length	mm	1219
		in	48.0
2	Load Center	mm	610
		in	24.0
	Static Tipping Load - Straight (Forks Level)	kg	11492
		lbs	25329
	Static Tipping Load - Articulated (Forks Level)	kg	10164
		lbs	22402
	Rated Load (SAE J1197 - 50% FTSTL)	kg	5082
		lbs	11201
	Rated Load (CEN EN 474-3 Rough Terrain - 60% FTSTL)	kg	6098
		lbs	13441
	Rated Load (CEN EN 474-3 Firm and Level Ground - 80% FTSTL)	kg	8131
		lbs	17921
3	Maximum Overall Length	mm	9155
		in	360.4
4	Reach with Forks at Ground Level	mm	1057
		in	41.6
5	*Ground to Bottom of Tine at Minimum Height and Fork Level	mm	-70
		in	-2.8
6	Reach with Arms Horizontal and Forks Level	mm	1678
		in	66.1
7	Reach with Fork at Maximum Height	mm	811
		in	31.9
8	Ground to Top of Tine with Arms Horizontal and Fork Level	mm	1987
		in	78.2
9	Ground to Top of Tine at Maximum Height and Fork Level	mm	4070
		in	160.2
10	Overall Height of Fork at Full Lift (top of carriage to ground)	mm	5110
		in	201.2
11	Clearance at Full Lift and Max Dump	mm	2837
		in	111.7
12	Max Discharge Angle from Horizontal	deg	49
13	Overall Carriage Width	mm	2528
		in	99.5
14	Overall Carriage Height	mm	1130
		in	44.5
15	Outside Tine Width (max spread)	mm	2178
		in	85.7
16	Outside Tine Width (min spread)	mm	576
		in	22.7
	Tine Width (single tine)	mm	180.0
		in	7.1
	Tine Thickness	mm	90.0
		in	3.5
	Tine Capacity	kg	22200
		lbs	48929
	Operating Weight	kg	21368
		lbs	47094

*Negative values indicate below grade

966 GC S5 Construction Fork, FUSION

96" Carriage
520-7957

48" Tine
520-7985

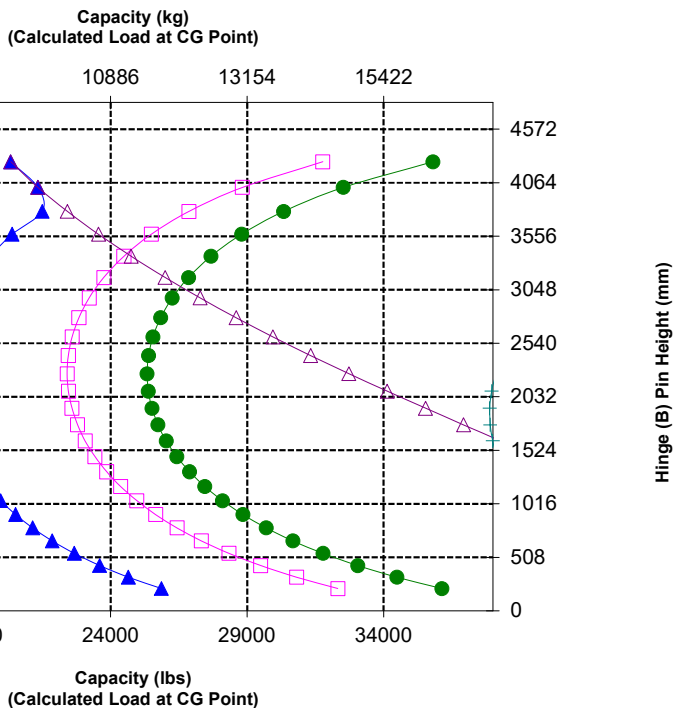
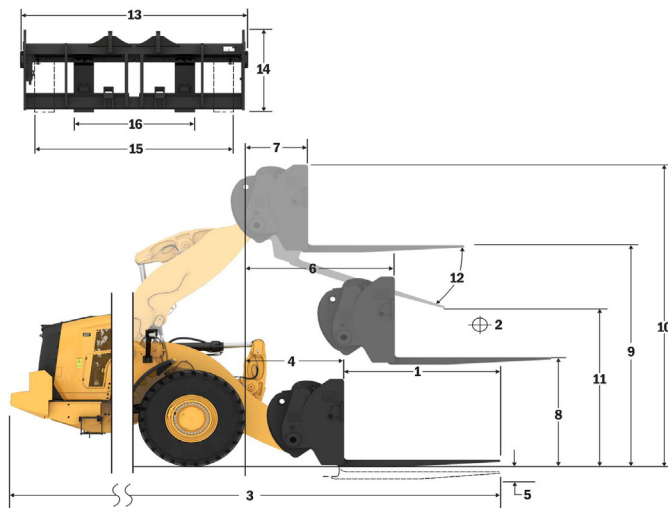

NOTE: Static tipping loads and operating weight are based on the following loader configuration: Maxam MS302 L3 Tires, Air Conditioning, Ride Control, Powertrain Guard, Full Fluids, Fuel Tank, Coolant, Lubricants, and Operator.

Specifications and ratings conform to the following standards: SAE* J1197, SAE J732, CEN** EN 474-3.

The rated operating load for a loader equipped with a pallet fork is determined by:
SAE J1197: 50% of full turn static tipping load or hydraulic limit.
CEN EN 474-3: 60% of full turn static tipping load on rough terrain or hydraulic limit.
CEN EN 474-3: 80% of full turn static tipping load on firm and level ground or hydraulic limit.

*SAE - Society of Automotive Engineers

**CEN - European Committee for Standardization



WARNING: Do not exceed tine load capacity. Individual tine capacity is stamped on the side of each tine.

966 GC Wheel Loader Specifications

Fork Specifications

Fork Specifications

1	Tine Length	mm	1524
		in	60.0
2	Load Center	mm	762
		in	30.0
	Static Tipping Load - Straight (Forks Level)	kg	10906
		lbs	24037
	Static Tipping Load - Articulated (Forks Level)	kg	9638
		lbs	21241
	Rated Load (SAE J1197 - 50% FTSTL)	kg	4819
		lbs	10621
	Rated Load (CEN EN 474-3 Rough Terrain - 60% FTSTL)	kg	5783
		lbs	12745
	Rated Load (CEN EN 474-3 Firm and Level Ground - 80% FTSTL)	kg	7710
		lbs	16993
3	Maximum Overall Length	mm	9460
		in	372.4
4	Reach with Forks at Ground Level	mm	1057
		in	41.6
5	*Ground to Bottom of Tine at Minimum Height and Fork Level	mm	-70
		in	-2.8
6	Reach with Arms Horizontal and Forks Level	mm	1678
		in	66.1
7	Reach with Fork at Maximum Height	mm	811
		in	31.9
8	Ground to Top of Tine with Arms Horizontal and Fork Level	mm	1987
		in	78.2
9	Ground to Top of Tine at Maximum Height and Fork Level	mm	4070
		in	160.2
10	Overall Height of Fork at Full Lift (top of carriage to ground)	mm	5110
		in	201.2
11	Clearance at Full Lift and Max Dump	mm	2606
		in	102.6
12	Max Discharge Angle from Horizontal	deg	49
13	Overall Carriage Width	mm	2528
		in	99.5
14	Overall Carriage Height	mm	1130
		in	44.5
15	Outside Tine Width (max spread)	mm	2178
		in	85.7
16	Outside Tine Width (min spread)	mm	576
		in	22.7
	Tine Width (single tine)	mm	180.0
		in	7.1
	Tine Thickness	mm	90.0
		in	3.5
	Tine Capacity	kg	17800
		lbs	39231
	Operating Weight	kg	21434
		lbs	47240

*Negative values indicate below grade

966 GC S5 Construction Fork, FUSION

96" Carriage 60" Tine
520-7957 520-7980

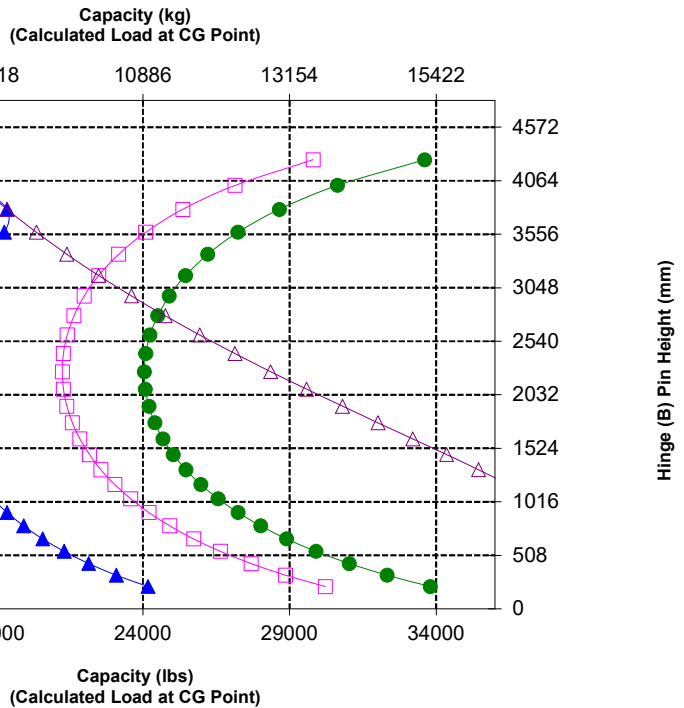
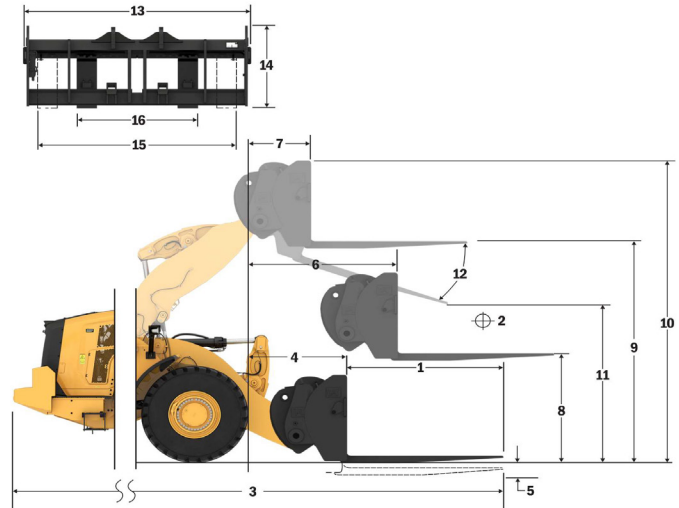

WARNING: Do not exceed tine load capacity. Individual tine capacity is stamped on the side of each tine.

966 GC Wheel Loader Specifications

Fork Specifications

Fork Specifications

1	Tine Length	mm	1829
		in	72.0
2	Load Center	mm	915
		in	36.0
	Static Tipping Load - Straight (Forks Level)	kg	10368
		lbs	22851
	Static Tipping Load - Articulated (Forks Level)	kg	9155
		lbs	20178
	Rated Load (SAE J1197 - 50% FTSTL)	kg	4577
		lbs	10089
	Rated Load (CEN EN 474-3 Rough Terrain - 60% FTSTL)	kg	5493
		lbs	12107
	Rated Load (CEN EN 474-3 Firm and Level Ground - 80% FTSTL)	kg	6981
		lbs	15387
3	Maximum Overall Length	mm	9765
		in	384.4
4	Reach with Forks at Ground Level	mm	1057
		in	41.6
5	*Ground to Bottom of Tine at Minimum Height and Fork Level	mm	-70
		in	-2.8
6	Reach with Arms Horizontal and Forks Level	mm	1678
		in	66.1
7	Reach with Fork at Maximum Height	mm	811
		in	31.9
8	Ground to Top of Tine with Arms Horizontal and Fork Level	mm	1987
		in	78.2
9	Ground to Top of Tine at Maximum Height and Fork Level	mm	4070
		in	160.2
10	Overall Height of Fork at Full Lift (top of carriage to ground)	mm	5110
		in	201.2
11	Clearance at Full Lift and Max Dump	mm	2376
		in	93.5
12	Max Discharge Angle from Horizontal	deg	49
13	Overall Carriage Width	mm	2528
		in	99.5
14	Overall Carriage Height	mm	1130
		in	44.5
15	Outside Tine Width (max spread)	mm	2178
		in	85.7
16	Outside Tine Width (min spread)	mm	576
		in	22.7
	Tine Width (single tine)	mm	180.0
		in	7.1
	Tine Thickness	mm	90.0
		in	3.5
	Tine Capacity	kg	14800
		lbs	32619
	Operating Weight	kg	21495
		lbs	47374

*Negative values indicate below grade

966 GC S5 Construction Fork, FUSION

96" Carriage 72" Tine
520-7957 520-7979

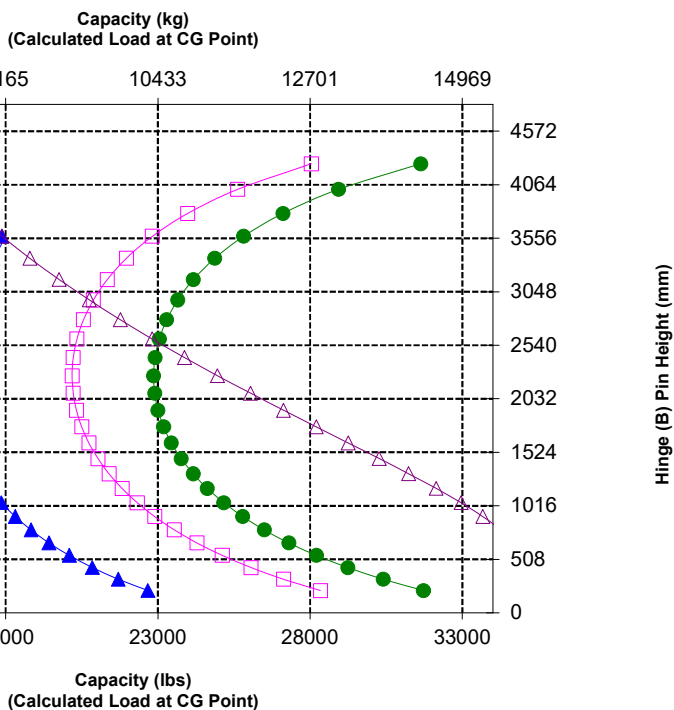
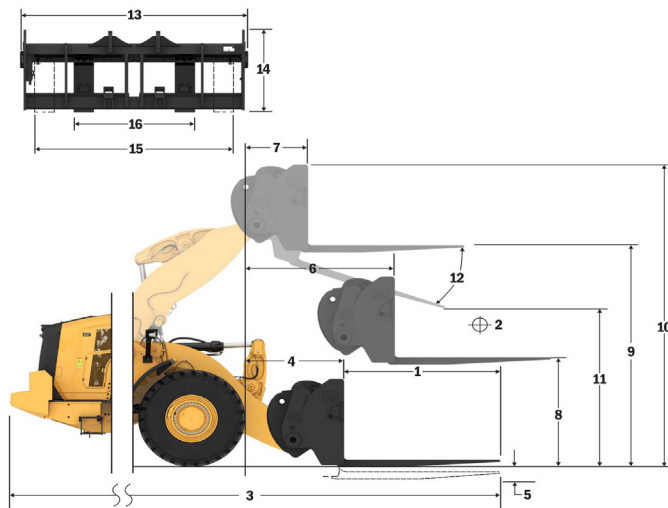

WARNING: Do not exceed tine load capacity. Individual tine capacity is stamped on the side of each tine.

966 GC Wheel Loader Specifications

Fork Specifications

Fork Specifications

1	Tine Length	mm	2134
		in	84.0
2	Load Center	mm	1067
		in	42.0
	Static Tipping Load - Straight (Forks Level)	kg	9868
		lbs	21750
	Static Tipping Load - Articulated (Forks Level)	kg	8706
		lbs	19187
	Rated Load (SAE J1197 - 50% FTSTL)	kg	4353
		lbs	9594
	Rated Load (CEN EN 474-3 Rough Terrain - 60% FTSTL)	kg	5223
		lbs	11512
	Rated Load (CEN EN 474-3 Firm and Level Ground - 80% FTSTL)	kg	6188
		lbs	13637
3	Maximum Overall Length	mm	10070
		in	396.4
4	Reach with Forks at Ground Level	mm	1057
		in	41.6
5	*Ground to Bottom of Tine at Minimum Height and Fork Level	mm	-70
		in	-2.8
6	Reach with Arms Horizontal and Forks Level	mm	1678
		in	66.1
7	Reach with Fork at Maximum Height	mm	811
		in	31.9
8	Ground to Top of Tine with Arms Horizontal and Fork Level	mm	1987
		in	78.2
9	Ground to Top of Tine at Maximum Height and Fork Level	mm	4070
		in	160.2
10	Overall Height of Fork at Full Lift (top of carriage to ground)	mm	5110
		in	201.2
11	Clearance at Full Lift and Max Dump	mm	2145
		in	84.5
12	Max Discharge Angle from Horizontal	deg	49
13	Overall Carriage Width	mm	2528
		in	99.5
14	Overall Carriage Height	mm	1130
		in	44.5
15	Outside Tine Width (max spread)	mm	2178
		in	85.7
16	Outside Tine Width (min spread)	mm	576
		in	22.7
	Tine Width (single tine)	mm	180.0
		in	7.1
	Tine Thickness	mm	90.0
		in	3.5
	Tine Capacity	kg	12700
		lbs	27991
	Operating Weight	kg	21558
		lbs	47513

*Negative values indicate below grade

966 GC S5 Construction Fork, FUSION

96" Carriage
520-7957

84" Tine
520-7986

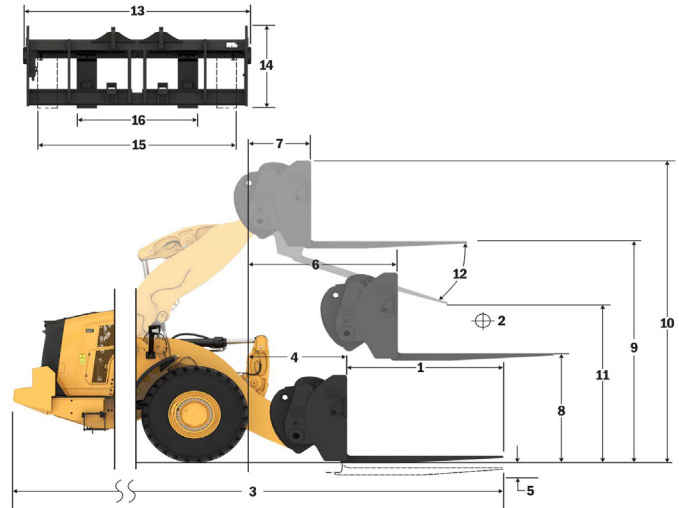

NOTE: Static tipping loads and operating weight are based on the following loader configuration: Maxam MS302 L3 Tires, Air Conditioning, Ride Control, Powertrain Guard, Full Fluids, Fuel Tank, Coolant, Lubricants, and Operator.

Specifications and ratings conform to the following standards: SAE* J1197, SAE J732, CEN** EN 474-3.

The rated operating load for a loader equipped with a pallet fork is determined by:
SAE J1197: 50% of full turn static tipping load or hydraulic limit.
CEN EN 474-3: 60% of full turn static tipping load on rough terrain or hydraulic limit.
CEN EN 474-3: 80% of full turn static tipping load on firm and level ground or hydraulic limit.

*SAE - Society of Automotive Engineers

**CEN - European Committee for Standardization

Capacity (kg)
(Calculated Load at CG Point)

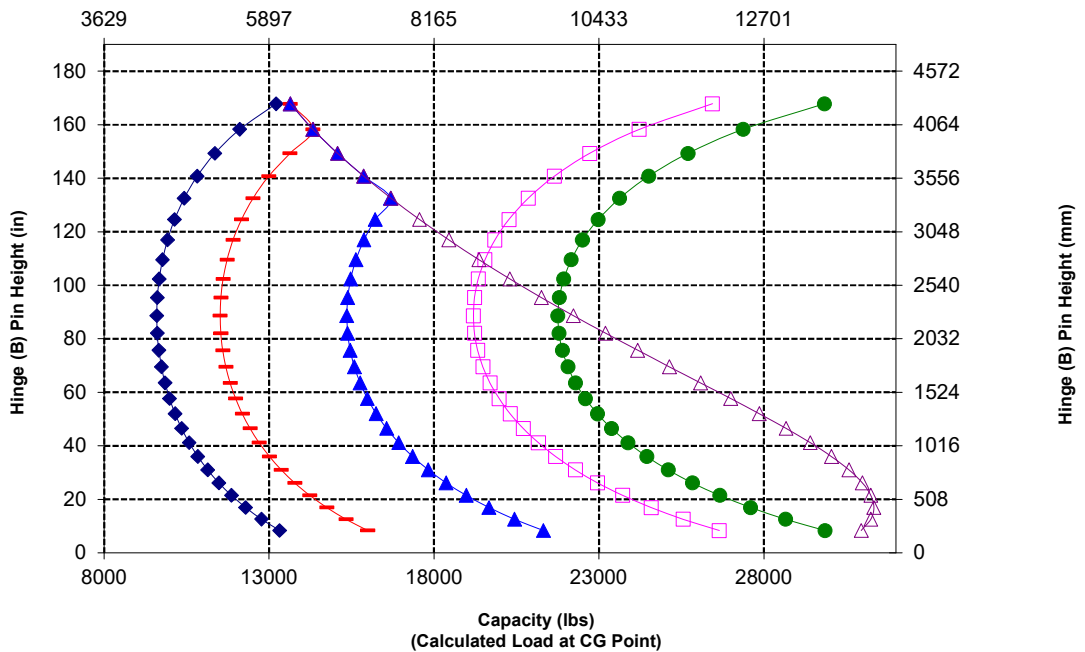

WARNING: Do not exceed tine load capacity. Individual tine capacity is stamped on the side of each tine.

966 GC Wheel Loader Specifications

Fork Specifications

Fork Specifications

1	Tine Length	mm	1219
		in	48.0
2	Load Center	mm	610
		in	24.0
	Static Tipping Load - Straight (Forks Level)	kg	11452
		lbs	25240
	Static Tipping Load - Articulated (Forks Level)	kg	10124
		lbs	22312
	Rated Load (SAE J1197 - 50% FTSTL)	kg	5062
		lbs	11156
	Rated Load (CEN EN 474-3 Rough Terrain - 60% FTSTL)	kg	6074
		lbs	13387
	Rated Load (CEN EN 474-3 Firm and Level Ground - 80% FTSTL)	kg	8099
		lbs	17850
3	Maximum Overall Length	mm	9155
		in	360.4
4	Reach with Forks at Ground Level	mm	1057
		in	41.6
5	*Ground to Bottom of Tine at Minimum Height and Fork Level	mm	-70
		in	-2.8
6	Reach with Arms Horizontal and Forks Level	mm	1678
		in	66.1
7	Reach with Fork at Maximum Height	mm	811
		in	31.9
8	Ground to Top of Tine with Arms Horizontal and Fork Level	mm	1987
		in	78.2
9	Ground to Top of Tine at Maximum Height and Fork Level	mm	4070
		in	160.2
10	Overall Height of Fork at Full Lift (top of carriage to ground)	mm	5110
		in	201.2
11	Clearance at Full Lift and Max Dump	mm	2837
		in	111.7
12	Max Discharge Angle from Horizontal	deg	49
13	Overall Carriage Width	mm	2833
		in	111.5
14	Overall Carriage Height	mm	1130
		in	44.5
15	Outside Tine Width (max spread)	mm	2493
		in	98.1
16	Outside Tine Width (min spread)	mm	590
		in	23.2
	Tine Width (single tine)	mm	180.0
		in	7.1
	Tine Thickness	mm	90.0
		in	3.5
	Tine Capacity	kg	22200
		lbs	48929
	Operating Weight	kg	21421
		lbs	47211

*Negative values indicate below grade

966 GC S5 Construction Fork, FUSION

108" Carriage 48" Tine
520-7968 520-7985

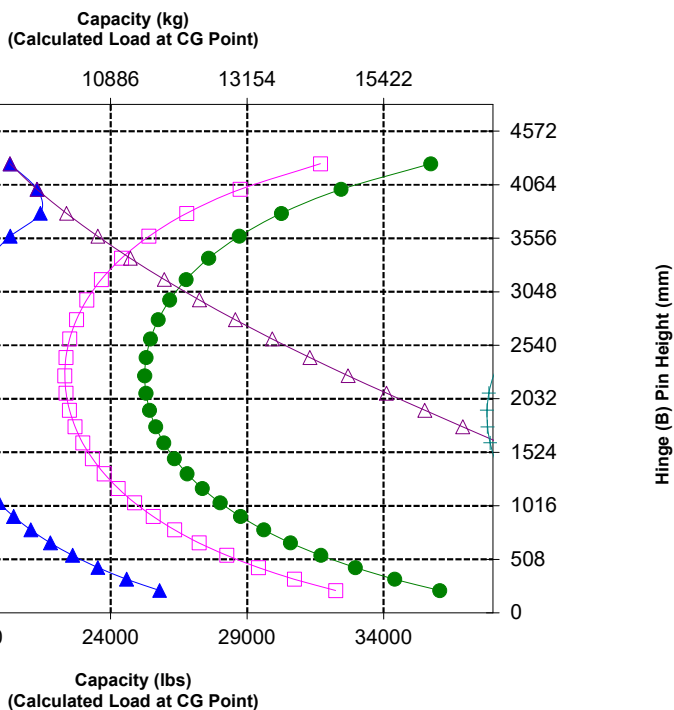
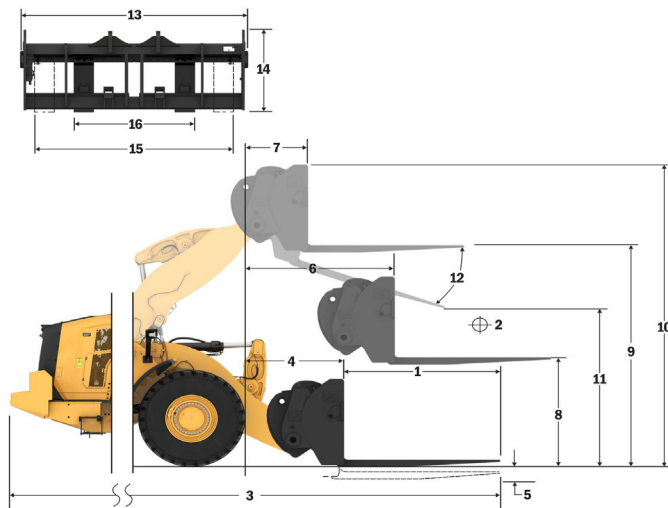

WARNING: Do not exceed tine load capacity. Individual tine capacity is stamped on the side of each tine.

966 GC Wheel Loader Specifications

Fork Specifications

Fork Specifications

1	Tine Length	mm	1524
		in	60.0
2	Load Center	mm	762
		in	30.0
	Static Tipping Load - Straight (Forks Level)	kg	10871
		lbs	23959
	Static Tipping Load - Articulated (Forks Level)	kg	9603
		lbs	21164
	Rated Load (SAE J1197 - 50% FTSTL)	kg	4801
		lbs	10582
	Rated Load (CEN EN 474-3 Rough Terrain - 60% FTSTL)	kg	5762
		lbs	12698
	Rated Load (CEN EN 474-3 Firm and Level Ground - 80% FTSTL)	kg	7682
		lbs	16931
3	Maximum Overall Length	mm	9460
		in	372.4
4	Reach with Forks at Ground Level	mm	1057
		in	41.6
5	*Ground to Bottom of Tine at Minimum Height and Fork Level	mm	-70
		in	-2.8
6	Reach with Arms Horizontal and Forks Level	mm	1678
		in	66.1
7	Reach with Fork at Maximum Height	mm	811
		in	31.9
8	Ground to Top of Tine with Arms Horizontal and Fork Level	mm	1987
		in	78.2
9	Ground to Top of Tine at Maximum Height and Fork Level	mm	4070
		in	160.2
10	Overall Height of Fork at Full Lift (top of carriage to ground)	mm	5110
		in	201.2
11	Clearance at Full Lift and Max Dump	mm	2606
		in	102.6
12	Max Discharge Angle from Horizontal	deg	49
13	Overall Carriage Width	mm	2833
		in	111.5
14	Overall Carriage Height	mm	1130
		in	44.5
15	Outside Tine Width (max spread)	mm	2483
		in	97.8
16	Outside Tine Width (min spread)	mm	590
		in	23.2
	Tine Width (single tine)	mm	180.0
		in	7.1
	Tine Thickness	mm	90.0
		in	3.5
	Tine Capacity	kg	17800
		lbs	39231
	Operating Weight	kg	21483
		lbs	47348

*Negative values indicate below grade

966 GC S5 Construction Fork, FUSION

108" Carriage 60" Tine
520-7968 520-7980

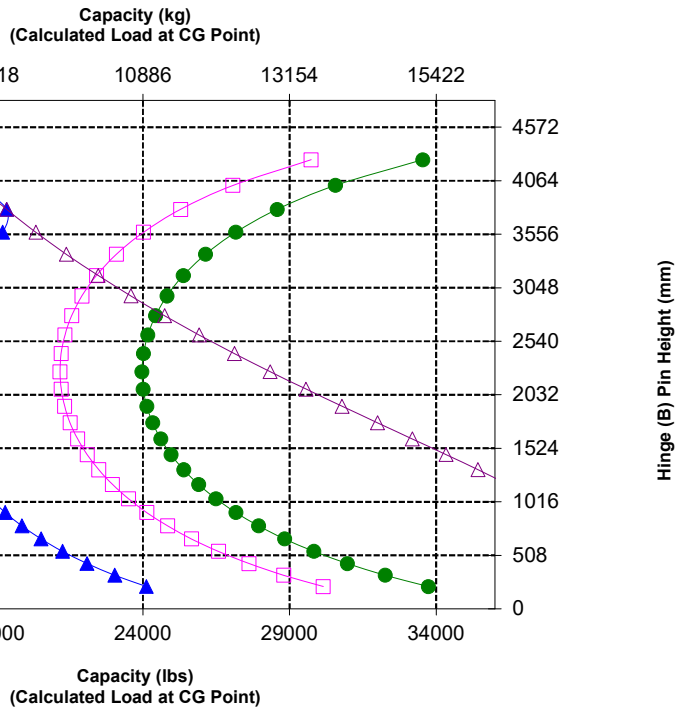
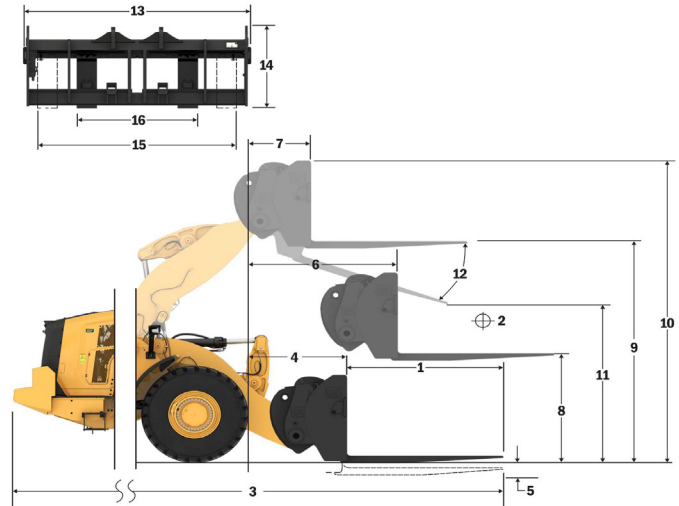

NOTE: Static tipping loads and operating weight are based on the following loader configuration: Maxam MS302 L3 Tires, Air Conditioning, Ride Control, Powertrain Guard, Full Fluids, Fuel Tank, Coolant, Lubricants, and Operator.

Specifications and ratings conform to the following standards: SAE* J1197, SAE J732, CEN** EN 474-3.

The rated operating load for a loader equipped with a pallet fork is determined by:
SAE J1197: 50% of full turn static tipping load or hydraulic limit.
CEN EN 474-3: 60% of full turn static tipping load on rough terrain or hydraulic limit.
CEN EN 474-3: 80% of full turn static tipping load on firm and level ground or hydraulic limit.

*SAE - Society of Automotive Engineers
**CEN - European Committee for Standardization



WARNING: Do not exceed tine load capacity. Individual tine capacity is stamped on the side of each tine.

966 GC Wheel Loader Specifications

Fork Specifications

Fork Specifications

1	Tine Length	mm	1829
		in	72.0
2	Load Center	mm	915
		in	36.0
	Static Tipping Load - Straight (Forks Level)	kg	10334
		lbs	22775
	Static Tipping Load - Articulated (Forks Level)	kg	9120
		lbs	20101
	Rated Load (SAE J1197 - 50% FTSTL)	kg	4560
		lbs	10051
	Rated Load (CEN EN 474-3 Rough Terrain - 60% FTSTL)	kg	5472
		lbs	12061
	Rated Load (CEN EN 474-3 Firm and Level Ground - 80% FTSTL)	kg	6973
		lbs	15369
3	Maximum Overall Length	mm	9765
		in	384.4
4	Reach with Forks at Ground Level	mm	1057
		in	41.6
5	*Ground to Bottom of Tine at Minimum Height and Fork Level	mm	-70
		in	-2.8
6	Reach with Arms Horizontal and Forks Level	mm	1678
		in	66.1
7	Reach with Fork at Maximum Height	mm	811
		in	31.9
8	Ground to Top of Tine with Arms Horizontal and Fork Level	mm	1987
		in	78.2
9	Ground to Top of Tine at Maximum Height and Fork Level	mm	4070
		in	160.2
10	Overall Height of Fork at Full Lift (top of carriage to ground)	mm	5110
		in	201.2
11	Clearance at Full Lift and Max Dump	mm	2376
		in	93.5
12	Max Discharge Angle from Horizontal	deg	49
13	Overall Carriage Width	mm	2833
		in	111.5
14	Overall Carriage Height	mm	1130
		in	44.5
15	Outside Tine Width (max spread)	mm	2483
		in	97.8
16	Outside Tine Width (min spread)	mm	590
		in	23.2
	Tine Width (single tine)	mm	180.0
		in	7.1
	Tine Thickness	mm	90.0
		in	3.5
	Tine Capacity	kg	14800
		lbs	32619
	Operating Weight	kg	21545
		lbs	47484

*Negative values indicate below grade

966 GC S5 Construction Fork, FUSION

108" Carriage 72" Tine
520-7968 520-7979

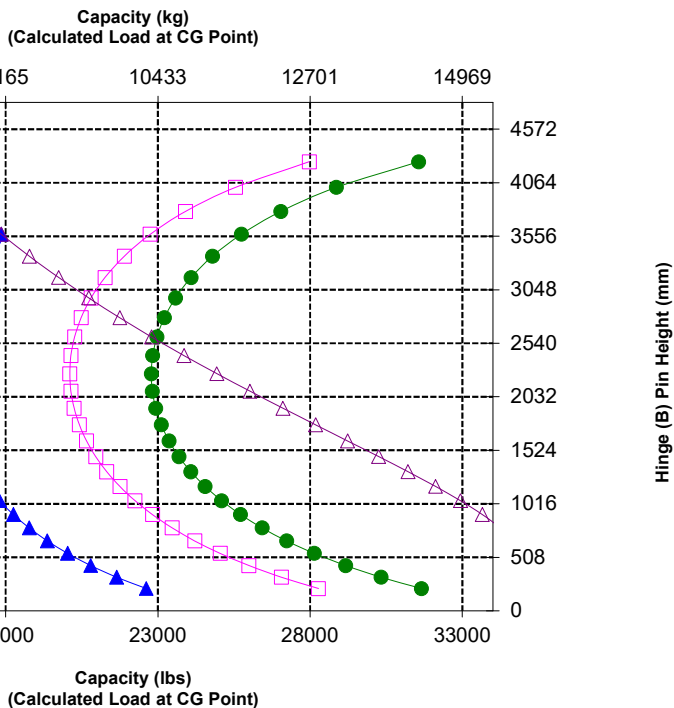
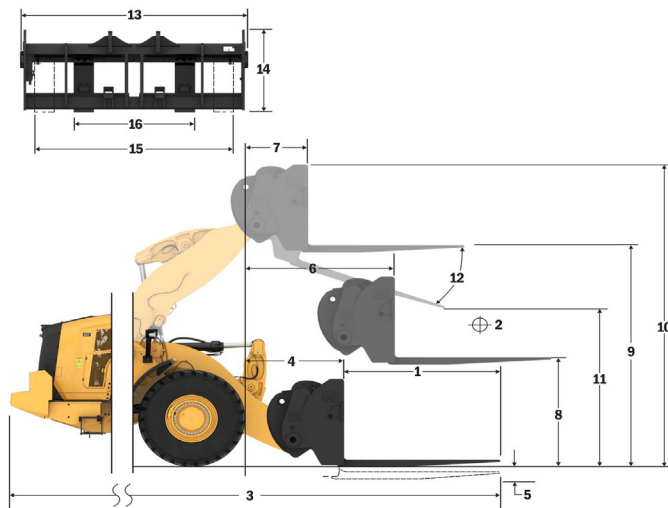

WARNING: Do not exceed tine load capacity. Individual tine capacity is stamped on the side of each tine.

966 GC Wheel Loader Specifications

Fork Specifications

Fork Specifications

1	Tine Length	mm	2134
		in	84.0
2	Load Center	mm	1067
		in	42.0
	Static Tipping Load - Straight (Forks Level)	kg	9836
		lbs	21679
	Static Tipping Load - Articulated (Forks Level)	kg	8673
		lbs	19116
	Rated Load (SAE J1197 - 50% FTSTL)	kg	4337
		lbs	9558
	Rated Load (CEN EN 474-3 Rough Terrain - 60% FTSTL)	kg	5204
		lbs	11470
	Rated Load (CEN EN 474-3 Firm and Level Ground - 80% FTSTL)	kg	6181
		lbs	13623
3	Maximum Overall Length	mm	10070
		in	396.4
4	Reach with Forks at Ground Level	mm	1057
		in	41.6
5	*Ground to Bottom of Tine at Minimum Height and Fork Level	mm	-70
		in	-2.8
6	Reach with Arms Horizontal and Forks Level	mm	1678
		in	66.1
7	Reach with Fork at Maximum Height	mm	811
		in	31.9
8	Ground to Top of Tine with Arms Horizontal and Fork Level	mm	1987
		in	78.2
9	Ground to Top of Tine at Maximum Height and Fork Level	mm	4070
		in	160.2
10	Overall Height of Fork at Full Lift (top of carriage to ground)	mm	5110
		in	201.2
11	Clearance at Full Lift and Max Dump	mm	2145
		in	84.5
12	Max Discharge Angle from Horizontal	deg	49
13	Overall Carriage Width	mm	2833
		in	111.5
14	Overall Carriage Height	mm	1130
		in	44.5
15	Outside Tine Width (max spread)	mm	2483
		in	97.8
16	Outside Tine Width (min spread)	mm	590
		in	23.2
	Tine Width (single tine)	mm	180.0
		in	7.1
	Tine Thickness	mm	90.0
		in	3.5
	Tine Capacity	kg	12700
		lbs	27991
	Operating Weight	kg	21607
		lbs	47621

*Negative values indicate below grade

966 GC S5 Construction Fork, FUSION

108" Carriage 84" Tine
520-7968 520-7986

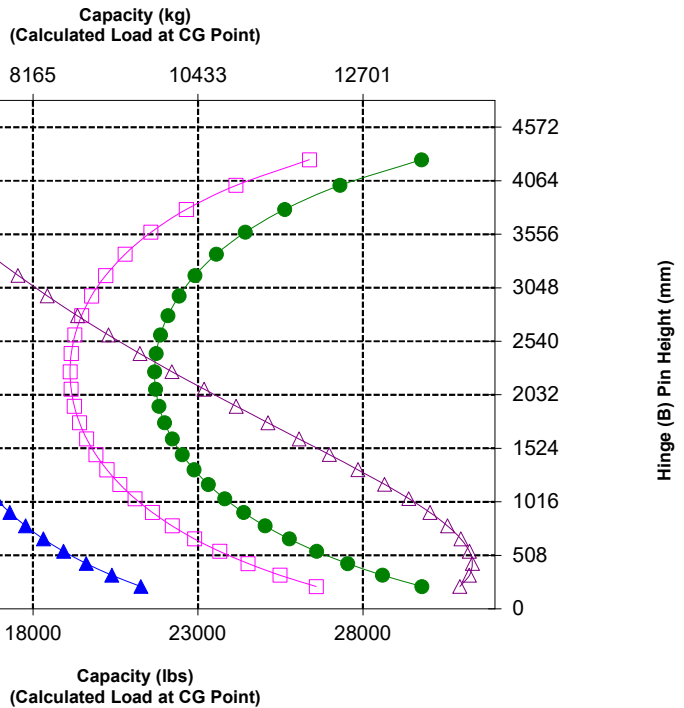
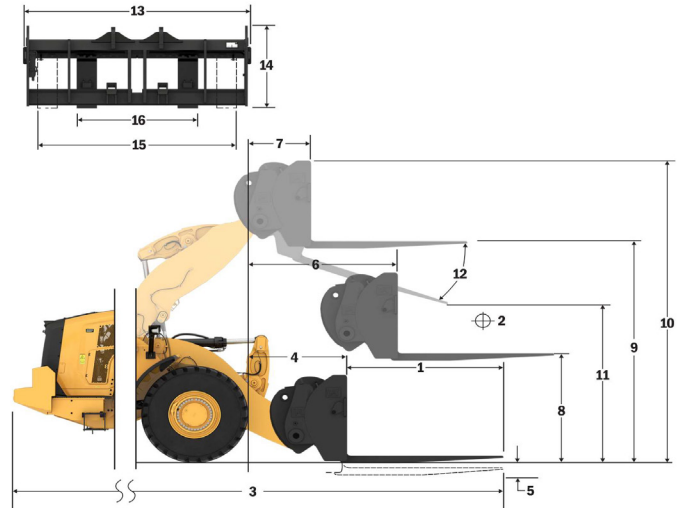

NOTE: Static tipping loads and operating weight are based on the following loader configuration: Maxam MS302 L3 Tires, Air Conditioning, Ride Control, Powertrain Guard, Full Fluids, Fuel Tank, Coolant, Lubricants, and Operator.

Specifications and ratings conform to the following standards: SAE* J1197, SAE J732, CEN** EN 474-3.

The rated operating load for a loader equipped with a pallet fork is determined by:
SAE J1197: 50% of full turn static tipping load or hydraulic limit.
CEN EN 474-3: 60% of full turn static tipping load on rough terrain or hydraulic limit.
CEN EN 474-3: 80% of full turn static tipping load on firm and level ground or hydraulic limit.

*SAE - Society of Automotive Engineers

**CEN - European Committee for Standardization



WARNING: Do not exceed tine load capacity. Individual tine capacity is stamped on the side of each tine.

966 GC Wheel Loader Specifications

Fork Specifications

Fork Specifications

1	Tine Length	mm	2438
		in	96.0
2	Load Center	mm	1219
		in	48.0
	Static Tipping Load - Straight (Forks Level)	kg	9374
		lbs	20661
	Static Tipping Load - Articulated (Forks Level)	kg	8258
		lbs	18200
	Rated Load (SAE J1197 - 50% FTSTL)	kg	4129
		lbs	9100
	Rated Load (CEN EN 474-3 Rough Terrain - 60% FTSTL)	kg	4955
		lbs	10920
	Rated Load (CEN EN 474-3 Firm and Level Ground - 80% FTSTL)	kg	5529
		lbs	12185
3	Maximum Overall Length	mm	10374
		in	408.4
4	Reach with Forks at Ground Level	mm	1057
		in	41.6
5	*Ground to Bottom of Tine at Minimum Height and Fork Level	mm	-70
		in	-2.8
6	Reach with Arms Horizontal and Forks Level	mm	1678
		in	66.1
7	Reach with Fork at Maximum Height	mm	811
		in	31.9
8	Ground to Top of Tine with Arms Horizontal and Fork Level	mm	1987
		in	78.2
9	Ground to Top of Tine at Maximum Height and Fork Level	mm	4070
		in	160.2
10	Overall Height of Fork at Full Lift (top of carriage to ground)	mm	5110
		in	201.2
11	Clearance at Full Lift and Max Dump	mm	1916
		in	75.4
12	Max Discharge Angle from Horizontal	deg	49
13	Overall Carriage Width	mm	2833
		in	111.5
14	Overall Carriage Height	mm	1130
		in	44.5
15	Outside Tine Width (max spread)	mm	2483
		in	97.8
16	Outside Tine Width (min spread)	mm	590
		in	23.2
	Tine Width (single tine)	mm	180.0
		in	7.1
	Tine Thickness	mm	90.0
		in	3.5
	Tine Capacity	kg	11300
		lbs	24905
	Operating Weight	kg	21670
		lbs	47760

*Negative values indicate below grade

966 GC S5 Construction Fork, FUSION

108" Carriage 96" Tine
520-7968 520-7981

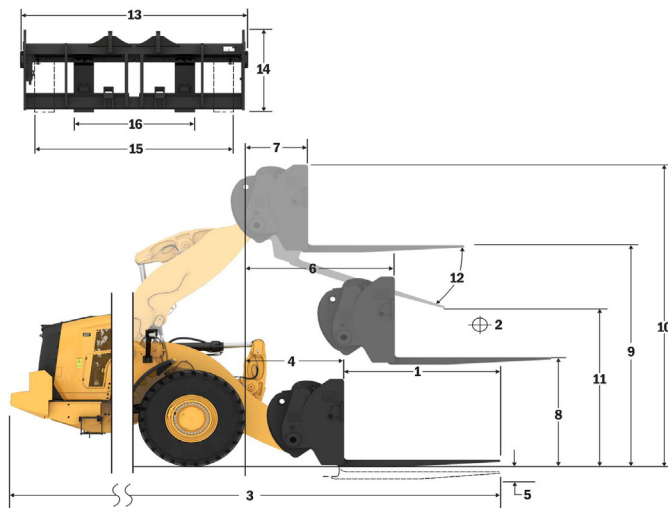

- ◆ Payload (SAE J1197)
- ◆ Payload (CEN EN 474-3 - Rough Terrain)
- ◆ Payload (CEN EN 474-3 - Firm & Level)
- ◆ Static Tipping Load - Articulated
- ◆ Static Tipping Load - Straight
- ◆ Hydraulic Tilt Capacity
- ◆ Hydraulic Lift Capacity

NOTE: Static tipping loads and operating weight are based on the following loader configuration: Maxam MS302 L3 Tires, Air Conditioning, Ride Control, Powertrain Guard, Full Fluids, Fuel Tank, Coolant, Lubricants, and Operator.

Specifications and ratings conform to the following standards: SAE* J1197, SAE J732, CEN** EN 474-3.

The rated operating load for a loader equipped with a pallet fork is determined by:
SAE J1197: 50% of full turn static tipping load or hydraulic limit.
CEN EN 474-3: 60% of full turn static tipping load on rough terrain or hydraulic limit.
CEN EN 474-3: 80% of full turn static tipping load on firm and level ground or hydraulic limit.

*SAE - Society of Automotive Engineers

**CEN - European Committee for Standardization

Capacity (kg)
(Calculated Load at CG Point)

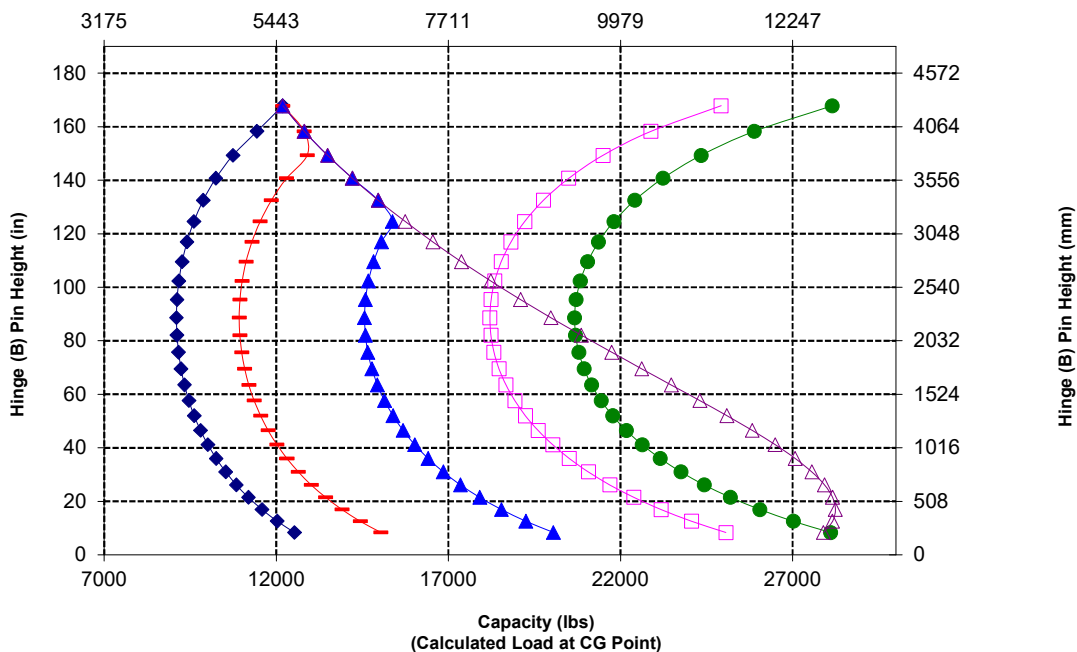

WARNING: Do not exceed tine load capacity. Individual tine capacity is stamped on the side of each tine.

966 GC Wheel Loader Specifications

Material Handling Arm Specifications

966 GC STD

Fusion Material Handling Arm 6Pos

624-9044

MHA Specifications

	Retracted	Extension 1	Extension 2	Extension 3	Extension 4	Extended
Max Lift - Hook Reach (1, 2, 3, 4, 5, 6)	mm 1,817	1,930	2,043	2,156	2,269	2,382
	ft, in 5' 11"	6' 3"	6' 8"	7' 0"	7' 5"	7' 9"
Max Lift - Hook Height (7, 8, 9, 10, 11, 12)	mm 7,228	7,511	7,794	8,077	8,360	8,643
	ft, in 23' 8"	24' 7"	25' 6"	26' 5"	27' 5"	28' 4"
Level - Hook Reach (13, 14, 15, 16, 17, 18)	mm 4,547	4,852	5,156	5,461	5,766	6,071
	ft, in 14' 11"	15' 11"	16' 11"	17' 11"	18' 11"	19' 11"
Level - Hook Height (19)	mm 1,947	1,947	1,947	1,947	1,947	1,947
	ft, in 6' 4.6"	6' 4.6"	6' 4.6"	6' 4.6"	6' 4.6"	6' 4.6"
Min Lift - Hook Reach (20, 21, 22, 23, 24, 25)	mm 1,714	1,846	1,977	2,108	2,239	2,371
	ft, in 5' 7"	6' 0"	6' 5"	6' 10"	7' 4"	7' 9"
Min Lift - Hook Height (26, 27, 28, 29, 30, 31)	mm (2,861)	(3,136)	(3,411)	(3,686)	(3,961)	(4,236)
	ft, in -9' 7"	-10' 8"	-11' 9"	-12' 10"	-12' 0"	-13' 1"
Static Tipping Load, Straight	kg 6,922	6,548	6,211	5,907	5,630	5,377
	lb 15,257	14,432	13,690	13,019	12,408	11,851
Static Tipping Load, Articulated	kg 6,136	5,803	5,504	5,233	4,987	4,762
	lb 13,523	12,790	12,131	11,534	10,992	10,496
Operating Weight	kg 20,616	20,616	20,616	20,616	20,616	20,616
	lb 45,438	45,438	45,438	45,438	45,438	45,438

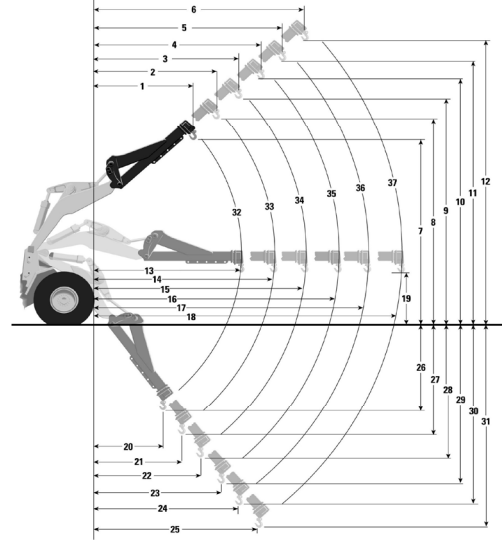

Payload Capacity (kg) (Calculated Load at CG Point)

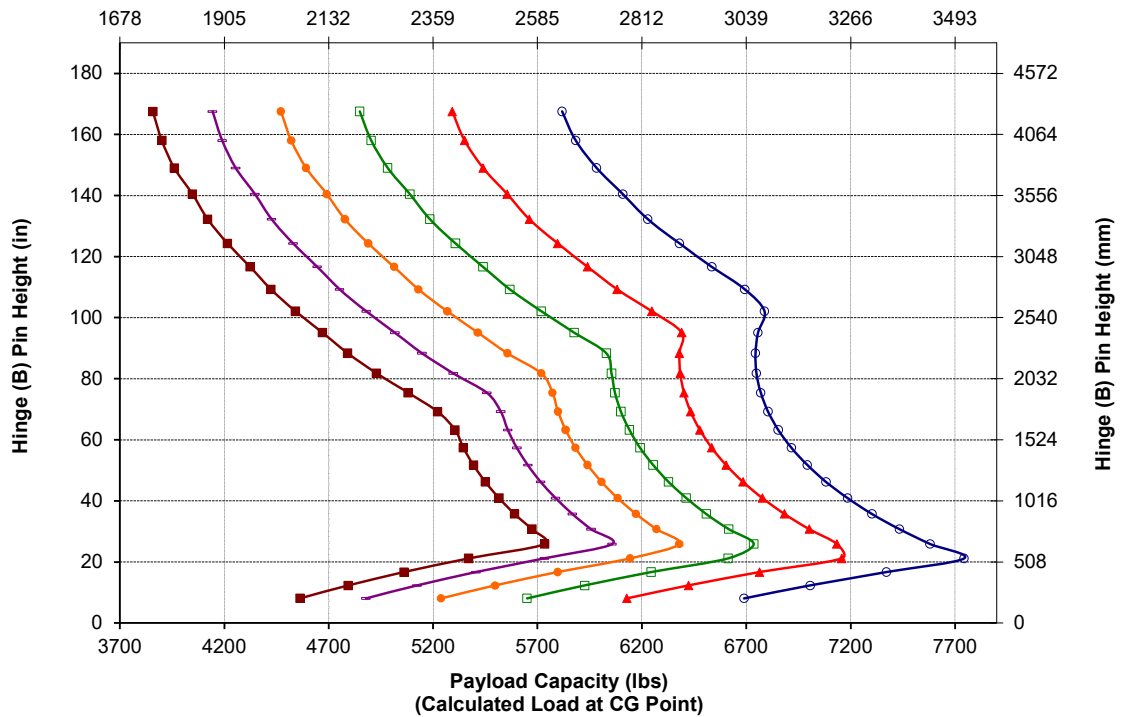

NOTE: Static tipping loads and operating weight are based on the following loader configuration: Maxam MS302 L3 Tires, Air Conditioning, Ride Control, Powertrain Guard, Full Fluids, Fuel Tank, Coolant, Lubricants, and Operator.

Specifications and ratings conform to the following standards: SAE* J1197, ISO 14397-1

The rated operating load for a loader equipped with a material handling arm is determined by:

SAE J1197: 50% of full turn static tipping load or hydraulic limit.

*SAE - Society of Automotive Engineers

966 GC Wheel Loader Specifications

Standard and Optional Equipment

Standard and optional equipment may vary. Consult your Cat dealer for details.

	Standard	Optional		Standard	Optional
OPERATOR ENVIRONMENT			HYDRAULICS		
Air conditioning (HVAC) with 10 vents and filter unit located outside of cab	✓		Dedicated brake and fan pump	✓	
Bucket/work tool function lockout	✓		Dedicated load sensing steering pump	✓	
Cab, pressurized and sound suppressed	✓		Load sensing implement system pilot operated	✓	
Camera, rearview	✓		Ride control		✓
CB radio ready		✓	S O-S SM oil sampling valves	✓	
Computerized monitoring system	✓		3 rd function with additional dedicated single axis lever		✓
Mirrors, rearview external with integrated spot mirror	✓		ELECTRICAL		
Pilot hydraulic controls, lift and tilt function; two (2) single axis levers or joystick	✓		Alarm, back-up variable/main disconnect switch	✓	
12V power port (10A)	✓		Alternator (145-amp, brush type)	✓	
Radio ready	✓		Batteries, maintenance free (2x1,125 CCA)	✓	
Radio: DAB+/AM/FM/BT		✓	Ignition key; start/stop	✓	
ROPS/FOPS structure	✓		Lighting system: 4 halogen work lights, cab mounted	✓	
Seat, Cat Comfort (cloth), mechanical suspension	✓		Lighting system: 8 halogen work lights, cab mounted		✓
Seat, high-back, air suspended		✓	Lighting system: 4 or 8LED work lights, cab mounted		✓
Seat, air suspended, heated		✓	Lights: LED taillights	✓	
Steering column, adjustable angle	✓		Lights: warning beacon		✓
Steering, secondary, electrical*		✓	Roading lights with high/low beam and F and R turn signals	✓	
Switch, transmission neutralizer (adjustable) lockout	✓		Starter, electric (heavy duty)	✓	
Window, sliding (left and right sides)	✓		Starting and charging system, 24V	✓	
Wipers/washers (front and rear)	✓		ADDITIONAL EQUIPMENT		
POWER TRAIN			Autolube system		✓
Axles, Open/Open differentials	✓		Camera, front view (kit)**		✓
Axles, limited slip differential(s)		✓	Cat Payload scale system		✓
Axles, oil cooler		✓	Cat Payload ready		✓
Brakes, full hydraulic enclosed wet-disc	✓		Cold weather starting basic (ether starting aid)	✓	
Cat C9.3B engine	✓		Cold weather starting full (HD batteries 2x1,400 CCA, ether system, jacket water heater, cold weather fluids)		✓
Engine Idle Management System (EIMS)	✓		Fender rear extensions or roading		✓
Auto Idle Shutdown (AIS)	✓		Grill, airborne debris	✓	
Fan, radiator, electronically controlled, hydraulically driven, temperature sensing, on demand	✓		Doors, service access (locking)	✓	
Fan, reversing automatic and manual control		✓	L5 traction tires		✓
Filter, fuel primary/secondary/tertiary	✓		L3 radial or bias ply tires	✓	
Fuel priming pump (electric)	✓		Powertrain guard		✓
Fuel/water separator	✓		Precleaner, strata tubes with screen		✓
Radiator, unit core (9.5 fpi) with ATAAC	✓		Product Link™ ready	✓	
Torque converter	✓		Reverse Stobe (kit)***		✓
Transmission, powershift (4F/4R), automatic (2-4) with kick-down 2-1 manual	✓		Roading Certification****		✓
LINKAGE			Tilt cylinder guard		✓
Fusion™ quick coupler control with dual kick outs		✓	Toolbox		✓
Lift and bucket return-to-dig kickouts (electro-magnetic), mechanical adjustment	✓		Variable backup alarm (3dB above ambient noise)	✓	
Z-bar, cast tilt lever	✓		Windshield guard		✓

* Standard where mandated.

** Refer to M0106413 publication for usage requirements.

*** Not compatible with roading arrangements.

**** Offering depends on region.

966 GC Environmental Declaration

The following information applies to the machine at the time of final manufacture as configured for sale in the regions covered in this document. The content of this declaration is valid as of the date issued; however, content related to machine features and specifications are subject to change without notice. For additional information, please see the machine's Operation and Maintenance Manual.

For more information on sustainability in action and our progress, please visit <https://www.caterpillar.com/en/company/sustainability>.

Engine

- Cat engine meets U.S. EPA Tier 4 Final, EU Stage V, Korea Stage V, China Nonroad Stage IV and Japan 2014 emission standards.
- The net power advertised is the power available at the flywheel when the engine is equipped with fan, alternator, air cleaner and aftertreatment.
- Cat diesel engines are required to use ULSD (ultra-low sulfur diesel fuel with 15 ppm of sulfur or less) or ULSD blended with the following lower-carbon intensity fuels up to:
 - 20% biodiesel FAME (fatty acid methyl ester)*
 - 100% renewable diesel, HVO (hydrotreated vegetable oil) and GTL (gas-to-liquid) fuels

Refer to guidelines for successful application. Please consult your Cat dealer or "Caterpillar Machine Fluids Recommendations" (SEBU6250) for details.

* Engines with no aftertreatment devices can use higher blends, up to 100% biodiesel.

Air Conditioning System

- The air conditioning system on this machine contains the fluorinated greenhouse gas refrigerant R134a (Global Warming Potential = 1430). The system contains 1.7 kg (3.7 lb) of refrigerant which has a CO2 equivalent of 2.431 metric tonnes (2.679 tons).

Paint

- Based on best available knowledge, the maximum allowable concentration, measured in parts per million (PPM), of the following heavy metals in paint are:
 - Barium < 0.01%
 - Cadmium < 0.01%
 - Chromium < 0.01%
 - Lead < 0.01%

Sound

Operator Sound Pressure Level (ISO 6396:2008)	73 dB(A)
Exterior Sound Power Level (ISO 6395:2008)	110 dB(A)
Operator Sound Pressure Level (ISO 6396:2008)	72 dB(A)*
Exterior Sound Power Level (ISO 6395:2008)	108 dB(A)**

*Including countries that adopt the EU and UK directives.

**EU Noise Directive 2000/14/EC and UK Noise Regulation 2001 No. 1701.

Oils and Fluids

- Caterpillar factory fills with ethylene glycol coolants. Cat Diesel Engine Antifreeze/Coolant (DEAC) and Cat Extended Life Coolant (ELC) can be recycled. Consult your Cat dealer for more information.
- Cat Bio HYDO Advanced is an EU Ecolabel approved biodegradable hydraulic oil.
- Additional fluids are likely to be present, please consult the Operations and Maintenance Manual or the Application and Installation guide for complete fluid recommendations and maintenance intervals.

Features and Technology

- The following features and technology may contribute to fuel savings and/or carbon reduction. Features may vary. Consult your Cat dealer for details.
 - Engine Idle Management System and Auto Engine Idle Shutdown reduces idle RPM and maximize fuel efficiency
 - Variable speed fan adjusts to meet machine cooling requirements to help save fuel
 - Load sensing hydraulics produce flow and pressure on-demand and only in amounts necessary to perform the needed functions

Recycling

- The materials included in machines are categorized as below with approximate weight percentage. Because of variations of product configurations, the following values in the table may vary.

Material Type	Weight Percentage
Steel	65.87%
Iron	12.57%
Nonferrous Metal	4.64%
Mixed Metal	0.31%
Mixed-Metal and Nonmetal	0.65%
Plastic	0.86%
Rubber	8.15%
Mixed Nonmetallic	0.00%
Fluid	2.85%
Other	3.81%
Uncategorized	0.29%
Total	100%

- A machine with higher recyclability rate will ensure more efficient usage of valuable natural resources and enhance End-of-Life value of the product. According to ISO 16714 (Earthmoving machinery – Recyclability and recoverability – Terminology and calculation method), recyclability rate is defined as percentage by mass (mass fraction in percent) of the new machine potentially able to be recycled, reused, or both.

All parts in the bill of material are first evaluated by component type based on a list of components defined by the ISO 16714 and Japan CEMA (Construction Equipment Manufacturers Association) standards. Remaining parts are further evaluated for recyclability based on material type.

Because of variations of product configurations, the following value in the table may vary.

Recyclability – 97%

