



D8

Track-Type Tractor

Technical Specifications

Configurations and features may vary by region. Please consult your Cat® dealer for availability in your area.

Table of Contents

D8 Track-Type Tractor

Specifications	2
Engine	2
Service Refill Capacities	2
Hydraulic Controls	2
Transmission	2
D8	3
Blades	3
D8 LGP	4
Blades	4
D8 Desert/High Abrasion	5
Blades	5
D8 LGP Desert/High Abrasion	6

D8 Waste Handler

Specifications	14
Engine	14
Service Refill Capacities	14
Hydraulic Controls	14
Transmission	14
D8 Waste Handler	15
Blades	15

Blades	6
Track Shoes	7
Rippers	7
Standards	8
Sound Level Information	8
Desert/High Abrasion	9
Extreme/Arctic Cold	9
Forestry/Land Clearing	9
Standard and Optional Equipment	10

D8 LGP Waste Handler	16
Blades	16
Track Shoes	17
Rippers	17
Standards	18
Sound Level Information	18
Standard and Optional Equipment	19

D8 Track-Type Tractor Specifications

Engine

Engine Model	Cat® C15	
Emissions	Brazil MAR-1, China Nonroad Stage III emission standards, equivalent to U.S. EPA Tier 3/EU Stage IIIA, or emits equivalent to China Nonroad Stage II/U.S. EPA Tier 2/EU Stage II	
Build Number	19B	
Engine Power (1,900 rpm)		
ISO 9249/SAE J1349	242 kW	325 hp
ISO 9249 (DIN)	328 mhp	
Engine Power (1,600 rpm)		
ISO 14396	269 kW	361 hp
ISO 14396 (DIN)	365 mhp	
Bore	137 mm	5.4 in
Stroke	172 mm	6.8 in
Displacement	15.2 L	928 in ³
Biofuel Capability	Up to B100 ¹	

- Net power advertised is the power available at the flywheel when the engine is equipped with fan, air cleaner, muffler, and alternator.
- Advertised power is tested per the specified standard in effect at the time of manufacture.
- No derating required up to 3658 m (12,000 ft) altitude, beyond 3658 m (12,000 ft) automatic derating occurs.

¹Cat engines are compatible with the following renewable, alternative, and biodiesel* fuels that reduce greenhouse gases on a lifecycle basis:

✓ Up to B20 biodiesel (FAME) **

✓ Up to 100% HVO and GTL renewable fuels

*Refer to guidelines for successful application. Please consult your Cat dealer or “Caterpillar Machine Fluids Recommendations” (SEBU6250) for details.

**B30, where mandated, can be used. For use of higher blends, up to B100, consult your Cat dealer.

**Up to B100 capable when equipped with optional B100-compliant fuel lines. Please consult the Operations and Maintenance Manual (OMM) for further information.

Service Refill Capacities

Fuel Tank	600 L	158.3 gal
Cooling System	62 L	16.4 gal
Engine Crankcase*	38 L	10 gal
Power Train	155 L	40.9 gal
Final Drives (each)	12.5 L	3.3 gal
Roller Frames (each)	65 L	17.2 gal
Pivot Shaft Compartment	40 L	10.6 gal

*With oil filters.

Hydraulic Controls

Pump Type	Piston-type, variable displacement	
Pump Output (steering)	276 L/min	71.8 gal/min
Pump Output (implement)	232 L/min	60.3 gal/min
Tilt Cylinder Rod End Flow	130 L/min	33.8 gal/min
Tilt Cylinder Head End Flow	170 L/min	44.2 gal/min
Bulldozer Relief Valve Setting	24 100 kPa	3,495.3 psi
Tilt Cylinder Relief Valve Setting	24 100 kPa	3,495.3 psi
Ripper (lift) Relief Valve Setting	24 100 kPa	3,495.3 psi
Ripper (pitch) Relief Valve Setting	24 100 kPa	3,495.3 psi
Steering	39 200 kPa	5,685.3 psi

Transmission

1 Forward	3.4 km/hr	2.1 mph
2 Forward	6.1 km/hr	3.8 mph
3 Forward	10.6 km/hr	6.6 mph
1 Reverse	4.5 km/hr	2.8 mph
2 Reverse	8 km/hr	5.0 mph
3 Reverse	14.2 km/hr	8.8 mph
1 Forward – Drawbar Pull (1,000)	650.7 kN	146,283.2 lbf
2 Forward – Drawbar Pull (1,000)	356.9 kN	80,234.3 lbf
3 Forward – Drawbar Pull (1,000)	191.8 kN	43,118.3 lbf

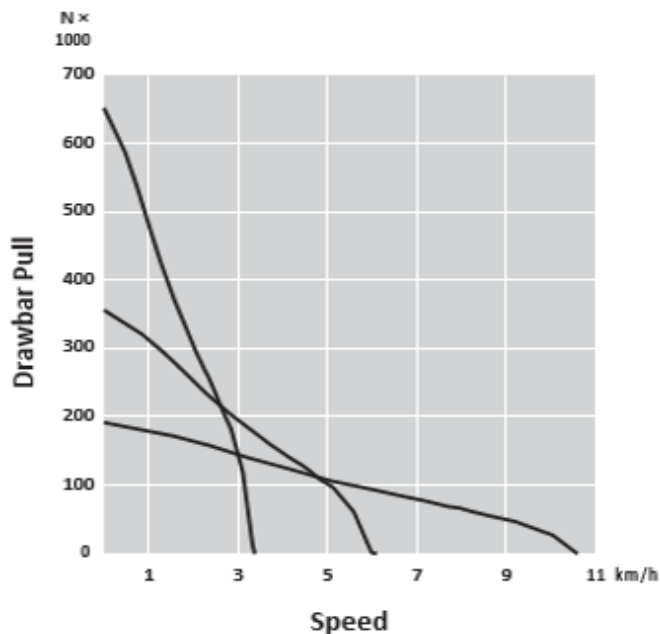

D8 Track-Type Tractor Specifications

D8

Operating Weight	38 834 kg	85,614 lb
Shipping Weight	30 036 kg	66,218 lb
Ground Pressure (ISO 16754)	88.2 kPa	12.8 psi
Shoe Type	Extreme Service	
Width of Standard Track Shoe	610 mm	24 in
Shoes/Side	44	
Track Rollers per Side	8	
Carrier Rollers per Side	1 (optional)	
Ground Contact Area (ISO 16754)	4.3 m ²	6,696 in ²
1 Track Gauge	2082 mm	82 in
2 Width of Tractor (without trunnions)	2743 mm	108 in
3 Machine Height from Tip of Grouser to Exhaust Stack	3452 mm	135.9 in
To Top of Cab	3503 mm	137.9 in
4 Length of Track on Ground	3206 mm	126.2 in
5 Length of Basic Tractor	4647 mm	183 in
With the following attachments add:		
Single Shank Ripper (with tip at ground line)	1519 mm	59.8 in
Multi-Shank Ripper (with tip at ground line)	1613 mm	63.5 in
Drawbar	406 mm	16 in
SU Blade	1904 mm	75 in
U Blade	2241 mm	88.2 in
A Blade (straight)	2027 mm	79.8 in
A Blade (angled 25 degrees)	3068 mm	120.8 in
Pitch	216 mm	8.5 in
6 Grouser Height	84 mm	3.3 in
7 Ground Clearance	622 mm	24.5 in

- Operating Weight – Standard: Includes hydraulic controls, blade, tilt cylinder, coolant, lubricants, 100% fuel, ROPS, FOPS cab, SU-Blade, Single-Shank Ripper, 610 mm (24 in) Extreme Service shoes, and operator.
- Shipping Weight – Standard: Includes coolant, lubricants, 20% fuel, ROPS, FOPS cab. Standard includes 610 mm (24 in) Extreme Service shoes.

Blades

Blades	Capacity	Width	Width over End Bits	Height	Dig Depth	Ground Clearance	Maximum Tilt	Blade Weight*
	m ³ (yd ³)	mm (ft)	mm (ft)	mm (ft)	mm (in)	mm (in)	mm (in)	kg (lb)
Semi-Universal (SU)	10.3 (13.4)	3900 (12.8)	4042 (13.3)	1747 (5.7)	573 (22.6)	1255 (49.4)	895 (35.2)	4407 (9,716)
SU with Rock Guard, Wear Plate	10.3 (13.4)	3900 (12.8)	4042 (13.3)	2017 (6.6)	573 (22.6)	1255 (49.4)	895 (35.2)	4998 (11,019)
SU with Push Plate	10.3 (13.4)	3900 (12.8)	4042 (13.3)	1747 (5.7)	573 (22.6)	1255 (49.4)	895 (35.2)	4655 (10,263)
SU with Performance Cutting Edges	10.3 (13.4)	3900 (12.8)	3962 (13)	1747 (5.7)	573 (22.6)	1255 (49.4)	895 (35.2)	4547 (10,024)
SU with Rock Guard, Performance Cutting Edges	10.3 (13.4)	3900 (12.8)	3962 (13)	2017 (6.6)	573 (22.6)	1255 (49.4)	895 (35.2)	5130 (11,310)
Universal	11.8 (15.4)	4123 (13.5)	4265 (14)	1732 (5.7)	573 (22.6)	1230 (48.4)	968 (38.1)	4895 (10,792)
Universal with Rock Guard, Wear Plate	11.8 (15.4)	4123 (13.5)	4265 (14)	2012 (6.6)	573 (22.6)	1230 (48.4)	968 (38.1)	5454 (12,024)
Angle Blade	5.2 (6.8)	4531 (14.9)	5043 (16.5)	1177 (3.9)	625 (24.6)	1323 (52.1)	733 (28.9)	5121 (11,289)

*Without hydraulic controls, includes blade tilt cylinder.

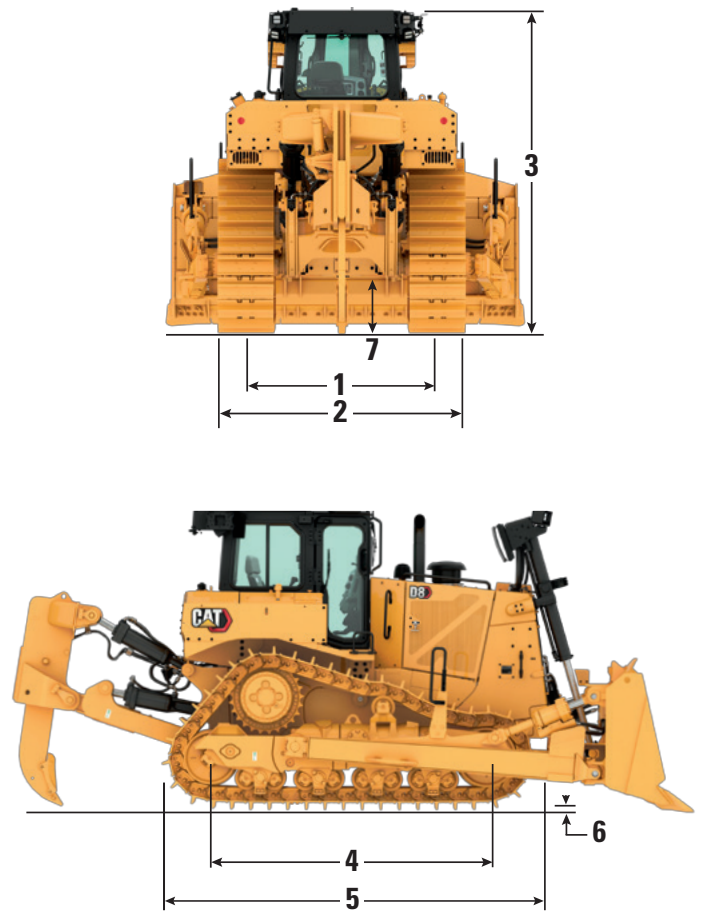

D8 LGP Track-Type Tractor Specifications

D8 LGP

Operating Weight	37 525 kg	82,728 lb
Shipping Weight	31 268 kg	68,934 lb
Ground Pressure (ISO 16754)	52.3 kPa	7.6 psi
Shoe Type	Extreme Service	
Width of Standard Track Shoe	965 mm	38 in
Shoes/Side	44	
Track Rollers per Side	8	
Carrier Rollers per Side	1 (optional)	
Ground Contact Area (ISO 16754)	6.8 m ²	10,594 in ²
1 Track Gauge	2337 mm	92 in
2 Width of Tractor (without trunnions)	3311 mm	130.4 in
3 Machine Height from Tip of Grouser to Exhaust Stack	3452 mm	135.9 in
To Top of Cab	3503 mm	137.9 in
4 Length of Track on Ground	3207 mm	126.3 in
5 Length of Basic Tractor	4647mm	183 in
With the following attachments add:		
Single Shank Ripper (with tip at ground line)	1519 mm	59.8 in
Multi-Shank Ripper (with tip at ground line)	1613 mm	63.5 in
Drawbar	406 mm	16 in
SU Blade	1844 mm	72.6 in
Pitch	216 mm	8.5 in
6 Grouser Height	84 mm	3.3 in
7 Ground Clearance	622 mm	24.5 in

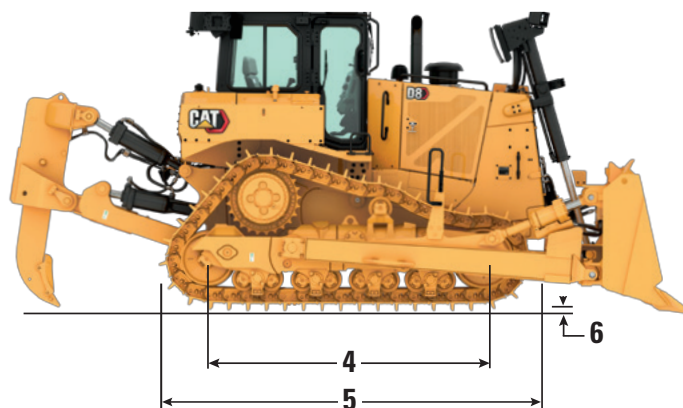
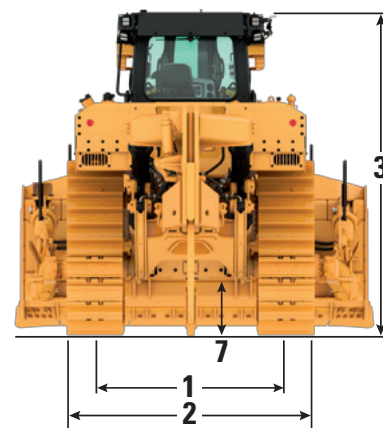

Note: Standard configuration shown.

- Operating Weight – LGP: Includes hydraulic controls, blade, tilt cylinder, drawbar, coolant, lubricants, 100% fuel, ROPS, FOPS cab, SU-Blade, 965 mm (38 in) Extreme Service shoes, and operator.
- Shipping Weight – LGP: Includes coolant, lubricants, 20% fuel, ROPS, FOPS cab, 965 mm (38 in) Extreme Service shoes.

Blades

Blades	Capacity	Width	Width over End Bits	Height	Dig Depth	Ground Clearance	Maximum Tilt	Blade Weight*
	m ³ (yd ³)	mm (ft)	mm (ft)	mm (ft)	mm (in)	mm (in)	mm (in)	kg (lb)
LGP Semi-Universal (SU)	9.9 (12.9)	4402 (14.4)	4543 (14.9)	1622 (5.3)	575 (22.64)	1228 (48.4)	859 (33.8)	4703 (10,368)
LGP Angle	5.6 (7.3)	5041 (16.5)	5553 (18.2)	1177 (3.9)	625 (24.61)	1323 (52.1)	657 (25.9)	5714 (12,597)

*Without hydraulic controls, includes blade tilt cylinder.

D8 Desert/High Abrasion Specifications

D8 Desert/High Abrasion

Operating Weight	39 153 kg	86,316 lb
Shipping Weight	30 355 kg	66,920 lb
Ground Pressure (ISO 16754)	88.2 kPa	12.8 psi
Shoe Type	Extreme Service	
Width of Standard Track Shoe	610 mm	24 in
Shoes/Side	44	
Track Rollers per Side	8	
Carrier Rollers per Side	1 (optional)	
Ground Contact Area (ISO 16754)	4.3 m ²	6,696 in ²
1 Track Gauge	2082 mm	982 in
2 Width of Tractor (without trunnions)	2743 mm	130.4 in
3 Machine Height from Tip of Grouser to Exhaust Stack	3452 mm	135.9 in
To Top of Cab	3503 mm	137.9 in
4 Length of Track on Ground	3206 mm	126.3 in
5 Length of Basic Tractor	4647 mm	183 in
With the following attachments add:		
Single Shank Ripper (with tip at ground line)	1519 mm	59.8
Multi-Shank Ripper (with tip at ground line)	1613 mm	63.5
Drawbar	406 mm	16 in
SU Blade	1904 mm	75 in
U Blade	2241 mm	88.2 in
A Blade (straight)	2027 mm	79.8 in
A Blade (angled 25 degrees)	3068 mm	120.8 in
Pitch	216 mm	8.5 in
6 Grouser Height	84 mm	3.3 in
7 Ground Clearance	622 mm	24.5 in

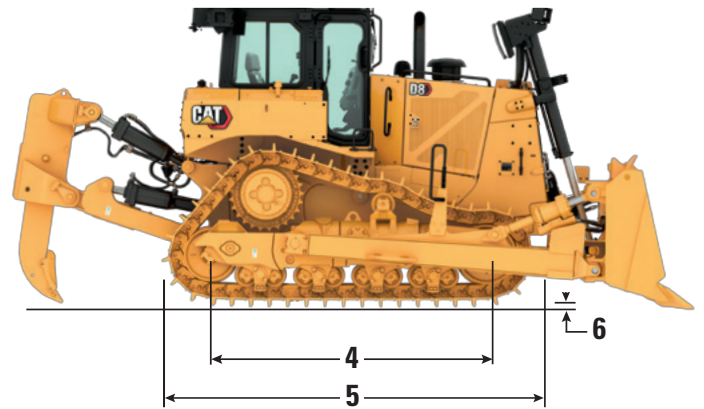
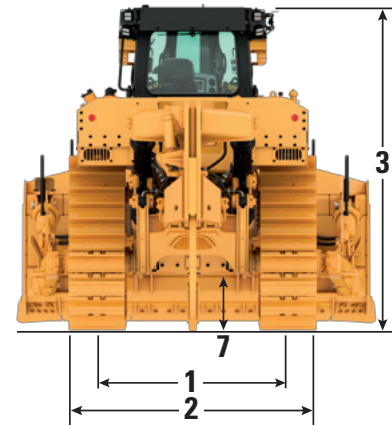

Note: Standard configuration shown.

- Operating Weight: Includes hydraulic controls, blade, tilt cylinder, coolant, lubricants, 100% fuel, ROPS, FOPS cab, SU-Blade, Single-Shank Ripper, 610 mm (24 in) Extreme Service shoes, carrier rollers and operator.
- Shipping Weight: Includes coolant, lubricants, 20% fuel, ROPS, FOPS cab, 610 mm (24 in) Extreme Service shoes and carrier rollers.

Blades

Blades	Capacity	Width	Width over End Bits	Height	Dig Depth	Ground Clearance	Maximum Tilt	Blade Weight*
	m ³ (yd ³)	mm (ft)	mm (ft)	mm (ft)	mm (in)	mm (in)	mm (in)	kg (lb)
Semi-Universal (SU)	10.3 (13.4)	3900 (12.8)	4042 (13.3)	1747 (5.7)	573 (22.6)	1255 (49.4)	895 (35.2)	4407 (9,716)
SU with Rock Guard, Wear Plate	10.3 (13.4)	3900 (12.8)	4042 (13.3)	2017 (6.6)	573 (22.6)	1255 (49.4)	895 (35.2)	4998 (11,019)
SU with Push Plate	10.3 (13.4)	3900 (12.8)	4042 (13.3)	1747 (5.7)	573 (22.6)	1255 (49.4)	895 (35.2)	4655 (10,263)
SU with Performance Cutting Edges	10.3 (13.4)	3900 (12.8)	3962 (13)	1747 (5.7)	573 (22.6)	1255 (49.4)	895 (35.2)	4547 (10,024)
SU with Rock Guard, Performance Cutting Edges	10.3 (13.4)	3900 (12.8)	3962 (13)	2017 (6.6)	573 (22.6)	1255 (49.4)	895 (35.2)	5130 (11,310)
Universal	11.8 (15.4)	4123 (13.5)	4265 (14)	1732 (5.7)	573 (22.6)	1230 (48.4)	968 (38.1)	4895 (10,792)
Universal with Rock Guard, Wear Plate	11.8 (15.4)	4123 (13.5)	4265 (14)	2012 (6.6)	573 (22.6)	1230 (48.4)	968 (38.1)	5454 (12,024)
Angle Blade	5.2 (6.8)	4531 (14.9)	5043 (16.5)	1177 (3.9)	625 (24.6)	1323 (52.1)	733 (28.9)	5121 (11,289)

*Without hydraulic controls, includes blade tilt cylinder.

D8 LGP Desert/High Abrasion Specifications

D8 LGP Desert/High Abrasion

Operating Weight	37 844 kg	82,728 lb
Shipping Weight	31 587 kg	68,934 lb
Ground Pressure (ISO 16754)	52.3 kPa	7.6 psi
Shoe Type	Extreme Service	
Width of Standard Track Shoe	965 mm	38 in
Shoes/Side	44	
Track Rollers per Side	8	
Carrier Rollers per Side	1 (optional)	
Ground Contact Area (ISO 16754)	6.8 m ²	10,594 in ²
1 Track Gauge	2337 mm	92 in
2 Width of Tractor (without trunnions)	3311 mm	130.4 in
3 Machine Height from Tip of Grouser to Exhaust Stack	3452 mm	135.9 in
To Top of Cab	3503 mm	137.9 in
4 Length of Track on Ground	3207 mm	126.3 in
5 Length of Basic Tractor	4647 mm	183 in
With the following attachments add:		
Single Shank Ripper (with tip at ground line)	1519 mm	59.8 in
Multi-Shank Ripper (with tip at ground line)	1613 mm	63.5 in
Drawbar	406 mm	16 in
SU Blade	1844 mm	72.6 in
Pitch	216 mm	8.5 in
6 Grouser Height	84 mm	3.3 in
7 Ground Clearance	622 mm	24.5 in

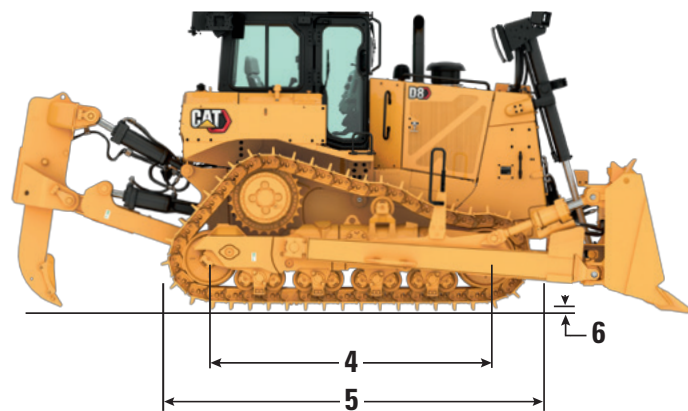
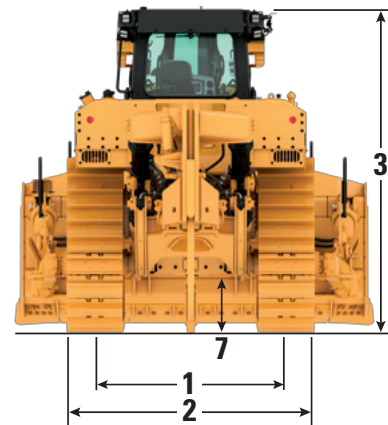

Note: Standard configuration shown.

- Operating Weight – LGP: Includes hydraulic controls, blade, tilt cylinder, drawbar, coolant, lubricants, 100% fuel, ROPS, FOPS cab, SU-Blade, 965 mm (38 in) Extreme Service shoes, carrier rollers, blast grid and operator.
- Shipping Weight – LGP: Includes coolant, lubricants, 20% fuel, ROPS, FOPS cab, 965 mm (38 in) Extreme Service shoes, carrier rollers and blast grid.

Blades

Blades	Capacity	Width	Width over End Bits	Height	Dig Depth	Ground Clearance	Maximum Tilt	Blade Weight*
	m ³ (yd ³)	mm (ft)	mm (ft)	mm (ft)	mm (in)	mm (in)	mm (in)	kg (lb)
LGP Semi-Universal (SU)	9.9 (12.9)	4402 (14.4)	4543 (14.9)	1622 (5.3)	575 (22.64)	1228 (48.4)	859 (33.8)	4703 (10,368)
LGP Angle	5.6 (7.3)	5041 (16.5)	5553 (18.2)	1177 (3.9)	625 (24.61)	1323 (52.1)	657 (25.9)	5714 (12,597)

*Without hydraulic controls, includes blade tilt cylinder.

Track Shoes

Track Shoes	560 mm	610 mm	660 mm	700 mm	710 mm	965 mm
Positive Pin Retention Rack	(22 in)	(24 in)	(26 in)	(27.5 in)	(28 in)	(38 in)
Moderate Service		✓			✓	✓
Extreme Service	✓	✓	✓		✓	✓
Extreme Service Trapezoidal	✓	✓	✓	✓		✓
Super Extreme Service Trapezoidal			✓			

Rippers

Single-Shank, Adjustable Parallelogram

Number of Pockets	1	
Added Length	1692 mm	66.6 in
Maximum Clearance Raised (under tip, pinned in bottom hole)	636 mm	25 in
Maximum Penetration (standard tip)	1130 mm	44.5 in
Maximum Penetration Force (shank vertical)	129.8 kN	29,180.2 lbf
Maximum Penetration Force with optional push block (1095 kg/4398 lb)	142.7 kN	32,080.2 lbf
Pry out Force	224.9 kN	50,559.5 lbf
Pry out Force with optional push block (1095 kg/4398 lb)	213.5 kN	47,996.7 lbf
Weight (without hydraulic controls)	4085 kg	9,005.9 lb
Weight – optional push block	1095 kg	2,414.1 lb

Multi-Shank, Adjustable Parallelogram

Number of Pockets	3	
Added Length	1598 mm	62.9 in
Overall Beam Width	2464 mm	97 in
Maximum Clearance Raised (under tip, pinned in bottom hole)	593 mm	23.3 in
Maximum Penetration (standard tip)	780 mm	30.7 in
Maximum Penetration Force (shank vertical)	124.2 kN	27,921.3 lbf
Pry out Force (multi-shank ripper with one tooth)	227.9 kN	5,1234 lbf
Weight (one shank, without hydraulic controls)	4877 kN	10,751.9 lb
Weight – additional shank	332 kN	731.9 lb

Standards

- ROPS (Rollover Protective Structure) offered by Caterpillar for the machine meets ROPS criteria ISO 3471:2008.
- FOPS (Falling Object Protective Structure) meets ISO 3449:2005 Level II.

Sound Level Information

Hearing protection may be needed when the machine is operated with an open operator station, in a noisy environment, with a cab that is not properly maintained, or when the doors and windows are open for extended periods of time.

Sound Level	Test Method	
Operator Sound Pressure Level	83 dB(A)	"ISO 6396:2008" (1)
	81 dB(A)*	
Exterior Sound Power Level	117 dB(A)	"ISO 6395:2008" (2)
	113 dB(A)*	"ISO 6395:1988" (2)

* For machines required to meet applicable regional regulations of Ukraine and countries that adopt the "EU Directives"; or machines equipped with the sound-suppression package.

(1) The measurement was conducted at 70% of the maximum engine cooling fan speed. The sound level may vary at different engine cooling fan speeds. The measurement was conducted with the cab doors and the cab windows closed. The cab was properly installed and maintained.

(2) The measurement was conducted at 70% of the maximum engine cooling fan speed. The sound level may vary at different engine cooling fan speeds.

The sound levels listed above include both measurement uncertainty and uncertainty due to production variation.

Choose from a variety of factory options to equip your dozer for the challenges of working in the harshest applications.

Desert/High Abrasion

- Desert engine package
- Turbine precleaner
- Ducted alternator
- ROPS mounted air conditioner
- Solid-bottom engine enclosure doors
- Coated radiator fan and radiator core protection
- Reversing function is disabled on the hydraulic demand fan
- Heavy duty desert sealed bottom guard with access panels for cleanout
- Desert seals - sound suppression and debris protection
- High ambient lubricant
- Replaceable blade wear plates

Extreme/Arctic Cold

- Arctic cab with dual pane glass
- Cold weather undercarriage
- Cold weather carrier rollers
- Arctic final drives
- Arctic lubricant
- Arctic engine coolant (-51C)
- Heated/ventilated seat
- Solid engine enclosure
- Ether starting aid
- Engine coolant heater (240V)
- Hydraulically driven reversing fan
- 150 amp heavy duty alternator
- Heavy duty starter

Forestry/Land Clearing

- Sweeps
- Screens
- Muffler with thermal shield
- Guarded undercarriage
- Grill debris guard
- Heavy duty bottom guard
- Fuel tank guard
- Front striker bars

D8 Standard and Optional Equipment

Standard and Optional Equipment

Standard and optional equipment may vary. Consult your Cat dealer for details.

	Standard	Optional		Standard	Optional
POWER TRAIN			OPERATOR ENVIRONMENT		
Cat C15 diesel engine (Equivalent to China Nonroad Stage II/U.S. EPA Tier 2/EU Stage II)	✓		Cab – Integrated ROPS/FOPS operator station	✓	
Cat C15 diesel engine (Brazil MAR-1, China Nonroad Stage III, equivalent to U.S. EPA Tier 3/EU Stage IIIA)	✓		Cold weather cab		✓
Cat C15 diesel engine – desert (Equivalent to China Nonroad Stage II/U.S. EPA Tier 2/EU Stage II)		✓	Cloth seat	✓	
Cat C15 diesel engine – sound suppressed (Brazil MAR-1, China Nonroad Stage III, equivalent to U.S. EPA Tier 3/EU Stage IIIA)		✓	Vinyl seat		✓
Air cleaner – precleaner with strata tube dust ejector	✓		Cloth seat, heated and ventilated		✓
Air-to-Air Aftercooler (ATAAC)	✓		Adjustable armrest	✓	
Radiator fan	✓		Retractable seatbelt – 76 mm (3 in)	✓	
Coated radiator fan		✓	Differential steering tiller-bar dual twist control	✓	
Radiator core	✓		Heater and air conditioning	✓	
Electric fuel priming pump	✓		Electronic monitoring system: hydraulic temperature, powertrain temperature, engine coolant temperature, fuel level, engine speed/tachometer, service hour meter	✓	
Electronic parking brake	✓		Rear vision camera		✓
Electronically controlled powershift transmission	✓		Rear view mirror	✓	
Extended life coolant	✓		Decelerator pedal	✓	
Four planet double-reduction planetary final drives	✓		Dash footpads	✓	
Final drives – cold weather		✓	Glove box	✓	
Final drives – guarded		✓	System warning lamps	✓	
Final drives – LGP		✓	Wipers	✓	
Hydraulically driven reversing fan	✓		Lunchbox storage	✓	
Muffler with mitered stack	✓		Standard operator arrangement	✓	
Muffler with thermal shield		✓	Quick opening operator arrangement		✓
Prescreener	✓		5th percentile operator arrangement		✓
Precleaner	✓		MACHINE CONTROL		
Turbine precleaner		✓	Single tilt	✓	
Turbine precleaner with screen		✓	Dual tilt		✓
Torque divider	✓		Pilot hydraulics	✓	
Turbocharger	✓		E/H hydraulics		✓
Water separator	✓		TECHNOLOGY PRODUCTS		
			Product Link Cellular	✓	
			Product Link Satellite or Dual Mode		✓
			Attachment Ready Option (ARO)		✓
			Grade with Slope Assist		✓
			Compatibility with radios and base stations from Trimble, Topcon, and Leica	✓	
			Capability to install 3D grade systems from Trimble, Topcon, and Leica	✓	

Standard and Optional Equipment (continued)

Standard and optional equipment may vary. Consult your Cat dealer for details.

	Standard	Optional		Standard	Optional
HYDRAULICS			SERVICE AND MAINTENANCE		
Independent steering and implement hydraulic pumps	✓		Oil drain	✓	
Load sensing hydraulics – lift and tilt	✓		High speed oil change system		✓
Pilot Rear Hydraulics	✓		Fast fill fuel system		✓
E/H Rear Hydraulics		✓	Fast fill fuel system (ripper mounted)		✓
UNDERCARRIAGE			Fuel lines – B100 compliant (required for Indonesia)		✓
Standard Gauge	✓		High Capacity Fuel Tank – includes B100 compliant fuel lines		✓
Low Ground Pressure (LGP)		✓	Standard lubricant	✓	
Suspended Heavy Duty undercarriage	✓		High ambient lubricant		✓
Suspended Heavy Duty undercarriage – Waste		✓	Arctic lubricant		✓
Suspended Heavy Duty undercarriage – Cold Weather		✓	Engine coolant (-37C)	✓	
Sealed and lubricated track: 44 sections with two-piece master links	✓		Engine coolant arctic (-51C)		✓
Heavy Duty, Positive Pin Retention (PPR) Track	✓		Powertrain ecology drains		✓
560 mm (22 in) Extreme Service		✓	Engine coolant heater 240V		✓
560 mm (22 in) Extreme Service Trapezoidal		✓	S·O·S SM sampling ports	✓	
610 mm (24 in) Moderate Service	✓		Vandalism protection for fluid compartments and battery box	✓	
610 mm (24 in) Extreme Service		✓	Engine enclosures	✓	
610 mm (24 in) Extreme Service Trapezoidal		✓	Ground level service center with remote electrical disconnect, secondary shutdown switch and hour meter	✓	
610 mm (24 in) Super Extreme Service		✓	Hydraulic oil cooler	✓	
660 mm (26 in) Moderate Service		✓	Cat exclusive power train and hydraulic oil filters with extended service intervals	✓	
660 mm (26 in) Extreme Service		✓	Front pull device	✓	
660 mm (26 in) Extreme Service Trapezoidal		✓	ELECTRICAL		
660 mm (26 in) Super Extreme Service Trapezoidal		✓	Back-up alarm	✓	
710 mm (28 in) Moderate Service		✓	Diagnostic connector	✓	
710 mm (28 in) Extreme Service		✓	Forward warning horn	✓	
710 mm (28 in) Moderate Service Trapezoidal		✓	Lights – 6	✓	
710 mm (28 in) Extreme Service Trapezoidal		✓	Lights – 10 LED		✓
965 mm (38 in) Moderate Service		✓	Lights – 8 (for Sweeps)		✓
965 mm (38 in) Extreme Service		✓	Underhood work light		✓
965 mm (38 in) Extreme Service Trapezoidal		✓	STARTERS, BATTERIES AND ALTERNATORS		
End track guiding guards	✓		150 Amp alternator	✓	
Equalizer bar	✓		150 Amp ducted alternator		✓
Hydraulic track adjusters	✓		Ether starting aid		✓
Lifetime lubricated idlers	✓		Two maintenance-free heavy duty 12V batteries (1400 CCA) (24V system)	✓	
Lifetime lubricated track rollers	✓		Auxiliary starting receptacle	✓	
Replaceable sprocket rim segments	✓		Heavy duty 24V starter	✓	
No carrier rollers	✓				
Carrier rollers, standard gauge		✓			
Carrier rollers, cold weather		✓			

D8 Standard and Optional Equipment

Standard and Optional Equipment (continued)

Standard and optional equipment may vary. Consult your Cat dealer for details.

	Standard	Optional		Standard	Optional
GUARDING AND SEALS			BLADES		
Fan debris guard		✓	Semi-Universal		✓
Grill debris guard		✓	Semi-Universal, ARO		✓
Hinged bottom guards	✓		Semi-Universal with push plate, ARO		✓
Bottom guards, sealed		✓	Semi-Universal with rock guard and wear plate, ARO		✓
Bottom guards, powered		✓	Universal, ARO		✓
Bottom guards, heavy duty sound suppressed		✓	Universal rock guard and wear plate, ARO		✓
Bottom guards, heavy duty, front counterweight		✓	Semi-Universal LGP, ARO		✓
Bottom guards, heavy duty desert		✓	Angle		✓
Fuel tank guard (with striker box)		✓	Angle LGP		✓
Fuel tank guard (without striker box)		✓	Semi-Universal Landfill with wear plate, ARO		✓
Fuel tank guard, high capacity (without striker box)		✓	Universal Landfill with wear plate, ARO		✓
Sweeps		✓	Semi-Universal LGP Landfill with wear plate, ARO		✓
Rear screen		✓	REAR ATTACHMENTS		
Front striker bars		✓	Single shank ripper		✓
Sound suppression seals		✓	Single shank ripper with pin puller		✓
Desert seals		✓	Single shank ripper with pin puller and striker bar		✓
Waste handling seals		✓	Single shank ripper with striker bar		✓
Push arm grab handles		✓	Single shank ripper with push block		✓
BULLDOZERS			Single shank ripper with pin puller, remote grease (Indonesia only)		✓
Lift cylinders		✓	Multi-shank ripper		✓
SU/U single tilt		✓	Multi-shank ripper with striker bar		✓
SU/U single tilt guarded		✓	Multi-shank ripper tooth		✓
SU/U dual tilt guarded		✓	Single shank ripper tooth		✓
Angle blade		✓	Single shank deep ripper tooth		✓
LGP SU single tilt		✓	Rigid drawbar		✓
LGP single tilt guarded		✓	Rear counterweight		✓
LGP dual tilt guarded		✓	Additional counterweight (drawbar)		✓
LGP, Angle blade		✓	Additional counterweight (striker box)		✓
SU/U single tilt with Slope Assist		✓	Rear striker bar box		✓
SU/U single tilt with Slope Assist, guarded		✓	No rear attachment	✓	
LGP Angle blade with Slope Assist		✓	Winch – dealer installed, please consult with your Cat dealer for options		✓
LGP SU single tilt with Slope Assist		✓	SPECIAL ARRANGEMENTS		
LGP SU single tilt with Slope Assist, guarded		✓	Waste Handler		✓
Angle blade with Slope Assist		✓			

Note: Choose from factory options to equip your dozer for work in desert/high abrasion conditions, extreme/arctic cold or forestry/land clearing.

D8

Waste Handler

From pushing trash to spreading cover, and cell construction to closing, Cat Waste Handlers are designed and manufactured from the frame up to take on the demands of landfill work. Specialized guarding throughout the machine helps protect major components like the chassis, fuel tank and hydraulic tank from impact and airborne debris.

Added Machine Protection

- Fuel tank guard and heavy duty bottom guards shield major machine components.
- Internal sealing keeps the trash away from the inner compartments.
- Heavy duty hinged radiator grill doors protect radiator and fan from penetration by material coming straight in or from under the blade.
- Thermal shields provide added protection in high debris applications.
- Rear striker bar helps protect against trash climbing up the tracks.
- Final drive guarding helps prevent wire wrap and helps keep dirt and debris away from seals.
- Rotating bushings on tilt cylinder lines help wrapping material to roll off hoses.
- 10 premium LED lights illuminate the work area.

Ease of Maintenance

- Air conditioning condenser and fans mounted on the back of the ROPS, away from debris for better cooling performance and to help prevent plugging.
- Heavy duty sealed bottom guard is hinged for easy cleaning.
- Quick access cab floor option offers toolless access to the floor plate opening.
- Ducted alternator for longer life.
- Engine turbine precleaner with screen delivers cleaner air to the power train.

Equipped for the Job

- Landfill blades are equipped with a trash rack to increase productive capacity when machine works in lighter material like waste.
- Wear plate helps extend blade life.
- Guarded undercarriage helps prevent debris such as wire, string or plastic bags from wrapping into seals.
- Trapezoidal center-hole track helps eject debris.

D8 Waste Handler Specifications

Engine

Engine Model	Cat C15	
Emissions	Brazil MAR-1, China Nonroad Stage III emission standards, equivalent to U.S. EPA Tier 3/EU Stage IIIA, or emits equivalent to China Nonroad Stage II/U.S. EPA Tier 2/EU Stage II	
Build Number	19B	
Engine Power (1,900 rpm)		
ISO 9249/SAE J1349	242 kW	325 hp
ISO 9249 (DIN)	328 mhp	
Engine Power (1,600 rpm)		
ISO 14396	269 kW	361 hp
ISO 14396 (DIN)	365 mhp	
Bore	137 mm	5.4 in
Stroke	172 mm	6.8 in
Displacement	15.2 L	928 in ³
Biofuel Capability	Up to B100 ¹	

- Net power advertised is the power available at the flywheel when the engine is equipped with fan, air cleaner, muffler, and alternator.
- Advertised power is tested per the specified standard in effect at the time of manufacture.
- No derating required up to 3658 m (12,000 ft) altitude, beyond 3658 m (12,000 ft) automatic derating occurs.

¹Cat engines are compatible with the following renewable, alternative, and biodiesel* fuels that reduce greenhouse gases on a lifecycle basis:

✓Up to B20 biodiesel (FAME) **

✓Up to 100% HVO and GTL renewable fuels

*Refer to guidelines for successful application. Please consult your Cat dealer or “Caterpillar Machine Fluids Recommendations” (SEBU6250) for details.

**B30, where mandated, can be used. For use of higher blends, up to B100, consult your Cat dealer.

**Up to B100 capable when equipped with optional B100-compliant fuel lines. Please consult the Operations and Maintenance Manual (OMM) for further information.

Service Refill Capacities

Fuel Tank	600 L	158.3 gal
Cooling System	62 L	16.4 gal
Engine Crankcase*	38 L	10 gal
Power Train	155 L	40.9 gal
Final Drives (each)	12.5 L	3.3 gal
Roller Frames (each)	65 L	17.2 gal
Pivot Shaft Compartment	40 L	10.6 gal

*With oil filters.

Hydraulic Controls

Pump Type	Piston-type, variable displacement	
Pump Output (steering)	276 L/min	71.8 gal/min
Pump Output (implement)	232 L/min	60.3 gal/min
Tilt Cylinder Rod End Flow	130 L/min	33.8 gal/min
Tilt Cylinder Head End Flow	170 L/min	44.2 gal/min
Bulldozer Relief Valve Setting	24 100 kPa	3,495.3 psi
Tilt Cylinder Relief Valve Setting	24 100 kPa	3,495.3 psi
Ripper (lift) Relief Valve Setting	24 100 kPa	3,495.3 psi
Ripper (pitch) Relief Valve Setting	24 100 kPa	3,495.3 psi
Steering	39 200 kPa	5,685.3 psi

Transmission

1 Forward	3.4 km/hr	2.1 mph
2 Forward	6.1 km/hr	3.8 mph
3 Forward	10.6 km/hr	6.6 mph
1 Reverse	4.5 km/hr	2.8 mph
2 Reverse	8 km/hr	5.0 mph
3 Reverse	14.2 km/hr	8.8 mph
1 Forward – Drawbar Pull (1,000)	650.7 kN	146,283.2 lbf
2 Forward – Drawbar Pull (1,000)	356.9 kN	80,234.3 lbf
3 Forward – Drawbar Pull (1,000)	191.8 kN	43,118.3 lbf

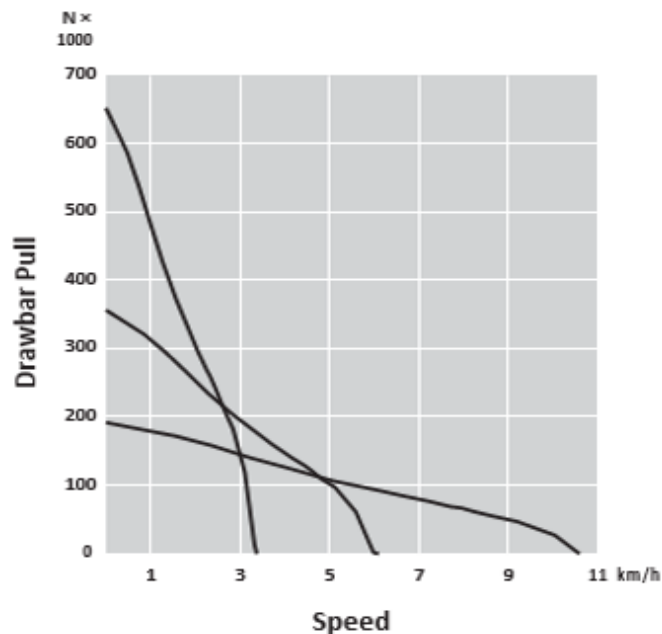

D8 Waste Handler Specifications

D8 Waste Handler

Operating Weight	38 621 kg	85,122 lb
Shipping Weight	29 823 kg	65,726 lb
Ground Pressure (ISO 16754)	88.2 kPa	12.8 psi
Shoe Type	Extreme Service	
Width of Standard Track Shoe	610 mm	24 in
Shoes/Side	44	
Track Rollers per Side	8	
Ground Contact Area (ISO 16754)	4.3 m ²	6,696 in ²
1 Track Gauge	2082 mm	82 in
2 Width of Tractor (without trunnions)	2743 mm	108 in
3 Machine Height from Tip of Grouser to Exhaust Stack	3452 mm	135.9 in
To Top of Cab	3503 mm	137.9 in
4 Length of Track on Ground	3206 mm	126.2 in
5 Length of Basic Tractor	4647 mm	183 in
With the following attachments add:		
Single Shank Ripper (with tip at ground line)	1519 mm	59.8 in
Multi-Shank Ripper (with tip at ground line)	1613 mm	63.5 in
Drawbar	406 mm	16 in
SU Blade	1904 mm	75 in
U Blade	2241 mm	88.2 in
Pitch	216 mm	8.5 in
6 Grouser Height	84 mm	3.3 in
7 Ground Clearance	622 mm	24.5 in

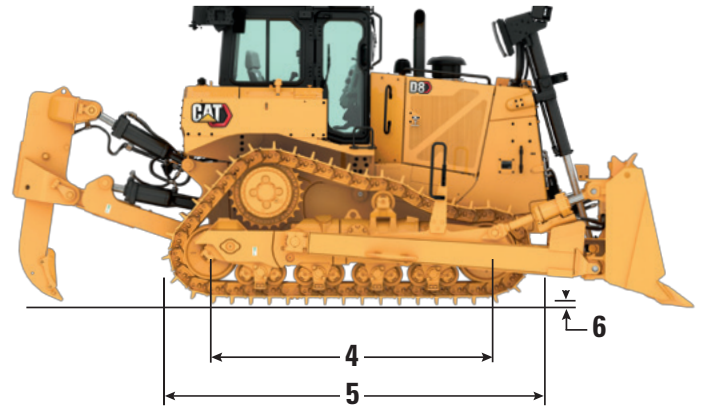
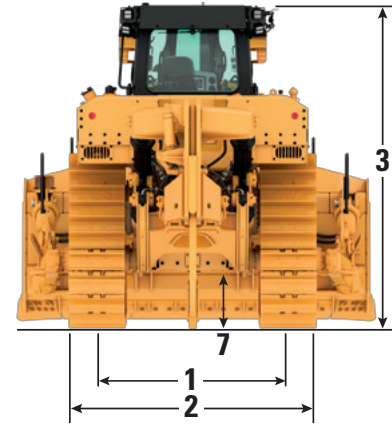

Note: Standard configuration shown.

- Operating Weight: Includes hydraulic controls, tilt cylinder, coolant, lubricants, 100% fuel, ROPS, FOPS cab, Waste Package, Waste SU-Blade, striker box, 610 mm (24 in) Extreme Service shoes and operator.
- Shipping Weight: Includes hydraulic controls, coolant, lubricants, 20% fuel, ROPS, FOPS cab, Waste Package, striker box, 610 mm (24 in) Extreme Service shoes.

Blades

Blades	Semi-Universal Landfill		Universal Landfill	
Capacity	21.2 m ³	27.8 yd ³	23.4 m ³	30.6 yd ³
Width*	3900 mm	12.8 ft	4123 mm	13.5 ft
Width over End Bits	4042 mm	13.3 ft	4265 mm	14 ft
Height	2553 mm	8.4 ft	2544 mm	8.3 ft
Digging Depth	573 mm	22.6 in	573 mm	22.6 in
Ground Clearance	1255 mm	49.4 in	1230 mm	48.4 in
Maximum Tilt	895 mm	35.2 in	968 mm	38.1 in
Weight* without hydraulic controls	5251 kg	11,576 lb	5840 kg	12,876 lb

*Without hydraulic controls, includes blade tilt cylinder.

D8 LGP Waste Handler Specifications

D8 LGP Waste Handler

Operating Weight	37 312 kg	82,236 lb
Shipping Weight	31 055 kg	68,442 lb
Ground Pressure (ISO 16754)	52.3 kPa	7.6 psi
Shoe Type	Extreme Service	
Width of Standard Track Shoe	965 mm	38 in
Shoes/Side	44	
Track Rollers per Side	8	
Ground Contact Area (ISO 16754)	6.8 m ²	10,594 in ²
1 Track Gauge	2337 mm	92 in
2 Width of Tractor (without trunnions)	3311 mm	130.4 in
3 Machine Height from Tip of Grouser to Exhaust Stack	3452 mm	135.9 in
To Top of Cab	3503 mm	137.9 in
4 Length of Track on Ground	3207 mm	126.3 in
5 Length of Basic Tractor	4647mm	183 in
With the following attachments add:		
Single Shank Ripper (with tip at ground line)	1519 mm	59.8 in
Multi-Shank Ripper (with tip at ground line)	1613 mm	63.5 in
Drawbar	406 mm	16 in
SU Blade	1844 mm	72.6 in
Pitch	216 mm	8.5 in
6 Grouser Height	84 mm	3.3 in
7 Ground Clearance	622 mm	24.5 in

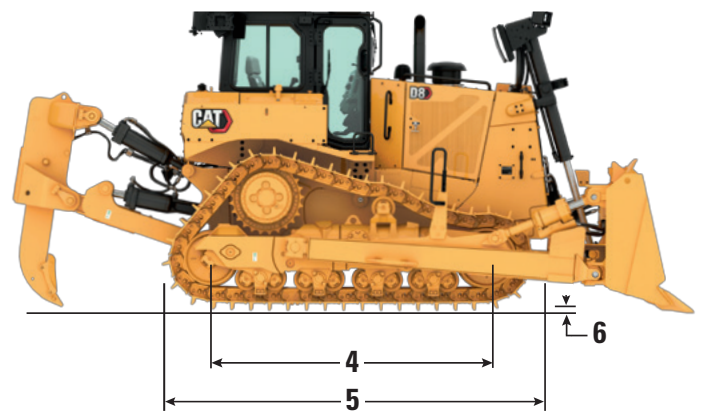
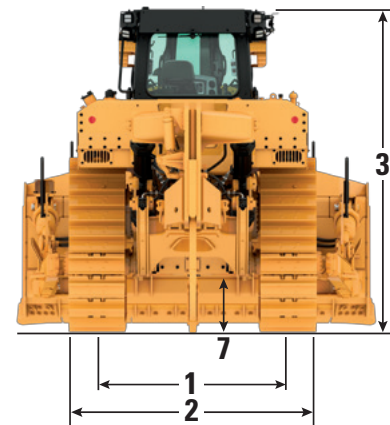

Note: Standard configuration shown.

- Operating Weight: Includes hydraulic controls, tilt cylinder, coolant, lubricants, 100% fuel, ROPS, FOPS cab, Waste Package, Waste LGP SU-Blade, striker box, 965 mm (38 in) Extreme Service shoes and operator.
- Shipping Weight: Includes coolant, lubricants, 20% fuel, ROPS, FOPS cab, Waste Package, striker box, 965 mm (38 in) Extreme Service shoes.

Blades

Landfill Blades	LGP Semi-Universal Landfill	
Capacity	22.2 m ³	29 yd ³
Width*	4402 mm	14.4 ft
Width over End Bits	4543 mm	14.9 ft
Height	2454 mm	8 ft
Digging Depth	575 mm	22.6 in
Ground Clearance	1228 mm	48.4 in
Maximum Tilt	859 mm	33.8 in
Weight* without hydraulic controls	5062 kg	11,159 lb

*Without hydraulic controls, includes blade tilt cylinder.

Track Shoes

Track Shoes	560 mm	610 mm	660 mm	700 mm	710 mm	965 mm
Positive Pin Retention Rack	(22 in)	(24 in)	(26 in)	(27.5 in)	(28 in)	(38 in)
Moderate Service		✓			✓	✓
Extreme Service	✓	✓	✓		✓	✓
Extreme Service Trapezoidal	*	*	*	*		*
Super Extreme Service Trapezoidal			✓			

✓ Available for Waste Handlers

* Recommended for Waste Handlers

Rippers

Single-Shank, Adjustable Parallelogram

Number of Pockets	1	
Added Length	1692 mm	66.6 in
Maximum Clearance Raised (under tip, pinned in bottom hole)	636 mm	25 in
Maximum Penetration (standard tip)	1130 mm	44.5 in
Maximum Penetration Force (shank vertical)	129.8 kN	29,180.2 lbf
Maximum Penetration Force with optional push block (1095 kg/4398 lb)	142.7 kN	32,080.2 lbf
Pry out Force	224.9 kN	50,559.5 lbf
Pry out Force with optional push block (1095 kg/4398 lb)	213.5 kN	47,996.7 lbf
Weight (without hydraulic controls)	4085 kg	9,005.9 lb
Weight – Optional Push Block	1095 kg	2,414.1 lb

Multi-Shank, Adjustable Parallelogram

Number of Pockets	3	
Added Length	1598 mm	62.9 in
Overall Beam Width	2464 mm	97 in
Maximum Clearance Raised (under tip, pinned in bottom hole)	593 mm	23.3 in
Maximum Penetration (standard tip)	780 mm	30.7 in
Maximum Penetration Force (shank vertical)	124.2 kN	27,921.3 lbf
Pry out Force (multi-shank ripper with one tooth)	227.9 kN	51,234 lbf
Weight (one shank, without hydraulic controls)	4877 kN	10,751.9 lb
Weight – additional shank	332 kN	731.9 lb

D8 Waste Handler Standards

Standards

- ROPS (Rollover Protective Structure) offered by Caterpillar for the machine meets ROPS criteria ISO 3471:2008.
- FOPS (Falling Object Protective Structure) meets ISO 3449:2005 Level II.

Sound Level Information

Hearing protection may be needed when the machine is operated with an open operator station, in a noisy environment, with a cab that is not properly maintained, or when the doors and windows are open for extended periods of time.

Sound Level	Test Method	
Operator Sound Pressure Level	83 dB(A)	"ISO 6396:2008" (1)
	81 dB(A)*	
Exterior Sound Power Level	117 dB(A)	"ISO 6395:2008" (2)
	113 dB(A)*	"ISO 6395:1988" (2)

* For machines required to meet applicable regional regulations of Ukraine and countries that adopt the "EU Directives"; or machines equipped with the sound-suppression package.

(1) The measurement was conducted at 70% of the maximum engine cooling fan speed. The sound level may vary at different engine cooling fan speeds. The measurement was conducted with the cab doors and the cab windows closed. The cab was properly installed and maintained.

(2) The measurement was conducted at 70% of the maximum engine cooling fan speed. The sound level may vary at different engine cooling fan speeds.

The sound levels listed above include both measurement uncertainty and uncertainty due to production variation.

D8 Waste Handler Standard and Optional Equipment

Standard and Optional Equipment

Standard and optional equipment may vary. Consult your Cat dealer for details.

	Standard	Optional		Standard	Optional
POWER TRAIN			OPERATOR ENVIRONMENT		
Cat C15 diesel engine (Brazil MAR-1, China Nonroad Stage III, equivalent to U.S. EPA Tier 3/EU Stage IIIA)	✓		Cab-Integrated ROPS/FOPS operator station	✓	
Cat C15 diesel engine – sound suppressed (Brazil MAR-1, China Nonroad Stage III, equivalent to U.S. EPA Tier 3/EU Stage IIIA)		✓	Cold weather cab		✓
Air cleaner – precleaner with strata tube dust ejector	✓		Cloth seat	✓	
Air-to-Air Aftercooler (ATAAC)	✓		Vinyl seat		✓
Radiator fan	✓		Cloth seat, heated and ventilated		✓
Coated radiator fan		✓	Adjustable armrest	✓	
Radiator core	✓		Retractable seatbelt – 76 mm (3 in)	✓	
Electric fuel priming pump	✓		Differential steering tiller-bar dual twist control	✓	
Electronic parking brake	✓		Heater and air conditioning	✓	
Electronically controlled powershift transmission	✓		Electronic monitoring system: hydraulic temperature, powertrain temperature, engine coolant temperature, fuel level, engine speed/tachometer, service hour meter	✓	
Extended life coolant	✓		Rear vision camera		✓
Four planet double-reduction planetary final drives	✓		Rear view mirror	✓	
Final drives – guarded	+		Decelerator pedal	✓	
Hydraulically driven reversing fan	✓		Dash footpads	✓	
Muffler with mitered stack	✓		Glove box	✓	
Muffler with thermal shield	+		System warning lamps	✓	
Prescreener	✓		Wipers	✓	
Precleaner	✓		Lunchbox storage	✓	
Turbine precleaner with screen	+		Quick opening operator arrangement	+	
Torque divider	✓		MACHINE CONTROL		
Turbocharger	✓		Single tilt	✓	
Water separator	✓		Dual tilt		✓
			Pilot hydraulics	✓	
			E/H hydraulics		✓
			TECHNOLOGY PRODUCTS		
			Product Link Cellular		✓
			Product Link Satellite or Dual Mode		✓
			Attachment Ready Option (ARO)		✓
			Grade with Slope Assist		✓
			Compatibility with radios and base stations from Trimble, Topcon, and Leica	✓	
			Capability to install 3D grade systems from Trimble, Topcon, and Leica	✓	

+ Included in Waste Handler package

D8 Waste Handler Standard and Optional Equipment

Standard and Optional Equipment (continued)

Standard and optional equipment may vary. Consult your Cat dealer for details.

	Standard	Optional		Standard	Optional
HYDRAULICS			SERVICE AND MAINTENANCE		
Independent steering and implement hydraulic pumps	✓		Oil drain	✓	
Load sensing hydraulics - lift and tilt	✓		High speed oil change system		✓
UNDERCARRIAGE			Fast fill fuel system		✓
Standard gauge	✓		Fast fill fuel system (ripper mounted)		✓
Low Ground Pressure (LGP)		✓	Fuel lines – B100 compliant (required for Indonesia)		✓
Suspended Heavy Duty undercarriage – Waste	+		High Capacity Fuel Tank - includes B100 compliant fuel lines		✓
Sealed and lubricated track: 44 sections with two-piece master links	✓		Standard lubricant	✓	
Heavy Duty, Positive Pin Retention (PPR) Track	✓		High ambient lubricant		✓
560 mm (22 in) Extreme Service		✓	Arctic lubricant		✓
560 mm (22 in) Extreme Service Trapezoidal		*	Engine coolant (-37C)	✓	
610 mm (24 in) Moderate Service	✓		Engine coolant arctic (-51C)		✓
610 mm (24 in) Extreme Service		✓	Powertrain ecology drains		✓
610 mm (24 in) Extreme Service Trapezoidal		*	Engine coolant heater 240V		✓
610 mm (24 in) Super Extreme Service		✓	S·O·S sampling ports	✓	
660 mm (26 in) Moderate Service		✓	Vandalism protection for fluid compartments and battery box	✓	
660 mm (26 in) Extreme Service		✓	Engine enclosures	✓	
660 mm (26 in) Extreme Service Trapezoidal		*	Ground level service center with remote electrical disconnect, secondary shutdown switch and hour meter	✓	
660 mm (26 in) Super Extreme Service Trapezoidal		✓	Hydraulic oil cooler	✓	
710 mm (28 in) Moderate Service		✓	Cat exclusive power train and hydraulic oil filters with extended service intervals	✓	
710 mm (28 in) Extreme Service		✓	Front pull device	✓	
710 mm (28 in) Moderate Service Trapezoidal		✓	ELECTRICAL		
710 mm (28 in) Extreme Service Trapezoidal		*	Back-up alarm	✓	
965 mm (38 in) Moderate Service		✓	Diagnostic connector	✓	
965 mm (38 in) Extreme Service		✓	Forward warning horn	✓	
965 mm (38 in) Extreme Service Trapezoidal		*	Lights – 6	✓	
End track guiding guards	✓		Lights – 10 LED		*
Equalizer bar	✓		Lights – 8 (for Sweeps)		✓
Hydraulic track adjusters	✓		Underhood work light		✓
Lifetime lubricated idlers	✓		STARTERS, BATTERIES AND ALTERNATORS		
Lifetime lubricated track rollers	✓		150 Amp ducted alternator	+	
Replaceable sprocket rim segments	✓		Ether starting aid		✓
No carrier rollers	+		Two maintenance-free heavy duty 12V batteries (1400 CCA) (24V system)	✓	
* Recommended			Auxiliary starting receptacle	✓	
+ Included in Waste Handler package			Heavy duty 24V starter	✓	

D8 Waste Handler Standard and Optional Equipment

Standard and Optional Equipment *(continued)*

Standard and optional equipment may vary. Consult your Cat dealer for details.

	Standard	Optional		Standard	Optional
GUARDING AND SEALS			BLADES		
Fan debris guard		✓	Semi-Universal Landfill with wear plate, ARO		*
Grill debris guard		✓	Universal Landfill with wear plate, ARO		*
Hinged bottom guards	✓		Semi-Universal LGP Landfill with wear plate, ARO		*
Bottom guards, sealed	+		Semi-Universal		✓
Bottom guards, powered		✓	Semi-Universal, ARO		✓
Bottom guards, heavy duty sound suppressed	+		Semi-Universal with push plate, ARO		✓
Bottom guards, heavy duty, front counterweight	+		Semi-Universal with rock guard and wear plate, ARO		✓
Fuel tank guard (with striker box)	+		Semi-Universal LGP, ARO		✓
Fuel tank guard (without striker box)	+		Universal, ARO		✓
Fuel tank guard, high capacity (without striker box)		✓	Universal rock guard and wear plate, ARO		✓
Sweeps		✓	REAR ATTACHMENTS		
Rear screen		✓	Single shank ripper		✓
Front striker bars		*	Single shank ripper with pin puller		✓
Sound suppression seals		✓	Single shank ripper with pin puller and striker bar		✓
Waste handling seals	+		Single shank ripper with striker bar		✓
Push arm grab handles		✓	Single shank ripper with push block		✓
BULLDOZERS			Single shank ripper with pin puller, remote grease (Indonesia only)		✓
Lift cylinders		✓	Multi-shank ripper		✓
SU/U single tilt		✓	Multi-shank ripper with striker bar		*
SU/U single tilt guarded		*	Multi-shank ripper tooth		✓
SU/U dual tilt guarded		*	Single shank ripper tooth		✓
LGP SU single tilt		✓	Single shank deep ripper tooth		✓
LGP single tilt, guarded		*	Rigid drawbar		✓
LGP dual tilt, guarded		*	Rear counterweight		✓
SU/U single tilt with Slope Assist		✓	Additional counterweight (drawbar)		✓
SU/U single tilt with Slope Assist, guarded		✓	Additional counterweight (striker box)		✓
LGP SU single tilt with Slope Assist		✓	Rear striker bar box		*
LGP SU single tilt with Slope Assist, guarded		✓	No rear attachment	✓	
			Winch – dealer installed, please consult with your Cat dealer for options		✓

* Recommended

+ Included in Waste Handler package

For more complete information on Cat products, dealer services, and industry solutions, visit us on the web at www.cat.com

© 2022 Caterpillar
All rights reserved

Materials and specifications are subject to change without notice. Featured machines in photos may include additional equipment. See your Cat dealer for available options.

CAT, CATERPILLAR, LET'S DO THE WORK, their respective logos, "Caterpillar Corporate Yellow," the "Power Edge" and Cat "Modern Hex" trade dress as well as corporate and product identity used herein, are trademarks of Caterpillar and may not be used without permission.

AEXQ3483-00 (01-2022)
Build Number: 19B
(Afr-ME, Aus-NZ, Eurasia, HK,
India, Indonesia, S Am, SE Asia,
Taiwan, Thailand, Turkey)

