



773G

Off-Highway Truck

Technical Specifications

Configurations and features may vary by region. Please consult your Cat® dealer for availability in your area.

Table of Contents

Specifications	2
Engine	2
Weight Distributions	2
Capacity	2
Transmission	2
Sound Levels	2
Final Drives	3
Brakes	3
Body Hoists	3
Suspension	3
Service Refill Capacities	3
Steering	3
Tires	3
Dimensions	3
ROPS	3
Weight/Payload Calculation	4
10/10/20 Payload Management Policy for Optimal Machine Life	5
Dimensions	6
Standard and Optional Equipment	7

773G Off-Highway Truck Specifications

Engine (Tier 2 Equivalent)

Engine Model	Cat® C27	
Rated Engine Speed	2,000 rpm	
Gross Power – SAE J1995:2014	578 kW	775 hp
Net Power – SAE J1349:2011	546 kW	733 hp
Net Power – ISO 9249:2007	552 kW	741 hp
Net Power – 80/1269/EEC	552 kW	741 hp
Engine Power – ISO 14396:2002	569 kW	763 hp
Peak Torque Speed	1,300 rpm	
Net Torque	3646 N·m	2,689 lb·ft
Bore	137 mm	5.4 in
Stroke	152 mm	6 in
Displacement	27 L	1,648 in ³

- Power rating applies at 2,000 rpm when tested under the specified condition for the specified standard.
- MIN NET SAE J1349/ISO 9249 Net power advertised is the power available at the flywheel when the engine is equipped with fan at maximum speed, air intake system, exhaust system, and alternator.
- Net power advertised is the power available at the flywheel when the engine is equipped with air intake system, exhaust system, and alternator.
- Advertised power is tested per the specified standard in effect at the time of manufacture.
- No engine derating required up to 3810 m (12,500 ft).
- Equivalent to U.S. EPA Tier 2.

Weight Distributions – Approximate

Front Axle – Empty	53%
Front Axle – Loaded	35%
Rear Axle – Empty	47%
Rear Axle – Loaded	65%

Capacity – Dual Slope – 100% Fill Factor

Struck	26.86 m ³	35.13 yd ³
Heaped 2:1 (SAE)	35.75 m ³	46.76 yd ³

- * Contact your local Cat dealer for body recommendation.
- * ISO 6483:1980

Capacity – Flat Floor – 100% Fill Factor

Struck	26.25 m ³	34.33 yd ³
Heaped 2:1 (SAE)	35.49 m ³	46.41 yd ³

- * Contact your local Cat dealer for body recommendation.
- * ISO 6483:1980

Transmission

Forward 1	10.8 km/h	6.7 mph
Forward 2	15.1 km/h	9.4 mph
Forward 3	20.4 km/h	12.7 mph
Forward 4	27.4 km/h	17.0 mph
Forward 5	37.0 km/h	23.0 mph
Forward 6	50.1 km/h	31.1 mph
Forward 7	67.6 km/h	42.0 mph
Reverse	14.1 km/h	8.8 mph

- Maximum travel speeds with standard 24.00R35 (E4) tires.

Sound

Sound Standards

- The operator Equivalent Sound Pressure Level (Leq) is 76 dB(A) when SAE J1166 FEB2008 is used to measure the value for an enclosed cab. This is a work cycle sound exposure level. The cab was properly installed and maintained. The test was conducted with the cab doors and the cab windows closed.
- The exterior sound pressure level for the standard machine measured at a distance of 15 m (49 ft) according to the test procedures specified in SAE J88:2006, mid-gear moving operation is 86 dB(A).
- Hearing protection may be needed when operating with an open operator station and cab (when not properly maintained or doors/windows open) for extended periods or in a noisy environment.

773G Off-Highway Truck Specifications

Final Drives

Differential Ratio	3.64:1
Planetary Ratio	4.80:1
Total Reduction Ratio	17.49:1

Brakes

Brake Surface – Front	655 cm ²	257 in ²
Brake Surface – Rear	61 269 cm ²	9,497 in ²
Brake Standards	ISO 3450:2011	

Body Hoists (Tier 2 Equivalent)

Pump Flow – High Idle	448 L/min	118 gal/min
Relief Valve Setting – Raise	17 250 kPa	2,502 psi
Relief Valve Setting – Lower	3450 kPa	500 psi
Body Raise Time – High Idle	9.5 seconds	
Body Lower Time – Float	13.0 seconds	
Body Power Down – High Idle	13.0 seconds	

Suspension

Empty Loaded Cylinder Stroke Front	234 mm	9.2 in
Empty Loaded Cylinder Stroke Rear	149 mm	5.8 in
Rear Axle Oscillation	8.1°	

Service Refill Capacities

Fuel Tank	795 L	210 gal
Cooling System	171 L	45 gal
Crankcase	90 L	24 gal
Differentials and Final Drives	145 L	38 gal
Steering Tank	36 L	9.5 gal
Steering System (includes tank)	54 L	14 gal
Brake/Hoist Hydraulic Tank	176 L	46.5 gal
Brake Hoist System	322 L	85 gal
Torque Converter/Transmission System HRC	70 L	18 gal
Torque Converter/Transmission System LRC	61 L	16 gal

Steering

Steering Standards	SAE J1511 FEB94 ISO 5010:2007	
Steer Angle	31°	
Turning Diameter – Front	23.5 m	77'1"
Turning Circle Clearance Diameter	26.1 m	85'8"

Tires

Standard Tire	24.00R35 (E4)
---------------	---------------

- Productive capabilities of the 773G truck are such that, under certain job conditions, TKPH (TMPH) capabilities of standard or optional tires could be exceeded and, therefore, limit production.
- Caterpillar recommends the customer evaluate all job conditions and consult the tire manufacturer for proper tire selection.

ROPS

ROPS/FOPS Standards

- ROPS (Rollover Protective Structure) for cab offered by Caterpillar meets ISO 3471:2008 ROPS criteria.
- FOPS (Falling Objects Protective Structure) meets ISO 3449:2005 Level II FOPS criteria.

773G Off-Highway Truck Specifications

Weight/Payload Calculation

773G – Flat Floor		Base Body	Base Body/Liner	Rubber Liner
Floor/Sidewall/Frontwall	mm (in)	20/10/12 (0.79/0.39/0.47)	36/18/22 (1.42/0.71/0.87)	102/8/8 + 20/10/12 (4.0/0.31/0.31) + (0.79/0.39/0.47)
Payload Capacity	m ³ (yd ³)	35.5 (46.4)	35.0 (45.8)	33.3 (43.6)
	mm (in)	20 (0.787)	36 (1.42)	102 (4.0)
Target Gross Machine Weight	kg (lb)	102 740 (226,503)	102 740 (226,503)	102 740 (226,503)
Empty Chassis Weight	kg (lb)	33 867 (74,663)	33 867 (74,663)	33 867 (74,663)
Body System Weight	kg (lb)	11 423 (25,183)	15 217 (33,547)	15 997 (35,267)
Empty Machine Weight	kg (lb)	45 290 (99,846)	49 084 (108,210)	49 864 (109,930)
Attachments				
Fuel Tank Size	L (gal)	795 (210)	795 (210)	795 (210)
Fuel Tank – 100% Fill	kg (lb)	669 (1,474)	669 (1,474)	669 (1,474)
Empty Operating Weight	kg (lb)	45 959 (101,322)	49 752 (109,684)	50 533 (111,406)
Target Payload (100%)*	kg (lb)	56 781 (125,181)	52 988 (116,819)	52 207 (115,097)
Target Payload Material Density	tonnes (tons)	56.8 (62.6)	53.0 (58.4)	52.2 (57.5)
Maximum Payload (110% of Target)*	kg (lb)	56 781 (125,181)	52 988 (116,819)	52 207 (115,097)
Maximum Payload Material Density	kg (lb)	62 460 (137,699)	58 287 (128,500)	57 428 (126,607)
Not to Exceed Payload (120% of Target)*	kg (lb)	68 138 (150,217)	63 585 (140,182)	62 649 (138,116)
Not to Exceed Payload Material Density	kg (lb)	114 096 (251,539)	113 338 (249,867)	113 181 (249,522)

*Refer to Caterpillar 10/10/20 Payload Policy.

Weight/Payload Calculation

773G – Dual Slope		Base Body	Base Body/Liner	No Rubber Liner Offered
Floor/Sidewall/Frontwall	mm (in)	20/10/12 (0.79/0.39/0.47)	36/18/22 (1.42/0.71/0.87)	
Payload Capacity	m ³ (yd ³)	35.8 (46.8)	35.2 (46.0)	
	mm (in)	20 (0.787)	36 (1.42)	
Target Gross Machine Weight	kg (lb)	102 740 (226,503)	102 740 (226,503)	
Empty Chassis Weight	kg (lb)	33 867 (74,663)	33 867 (74,663)	
Body System Weight	kg (lb)	11 049 (24,358)	14 776 (32,575)	
Empty Machine Weight	kg (lb)	44 916 (99,022)	48 643 (107,239)	
Attachments				
Fuel Tank Size	L (gal)	795 (210)	795 (210)	
Fuel Tank – 100% Fill	kg (lb)	669 (1,474)	669 (1,474)	
Empty Operating Weight	kg (lb)	45 585 (100,497)	49 312 (108,714)	
Target Payload (100%)*	kg (lb)	57 155 (126,006)	53 428 (117,789)	
Target Payload Material Density	tonnes (tons)	57.2 (63.0)	53.4 (58.9)	
Maximum Payload (110% of Target)*	kg (lb)	57 155 (126,006)	53 428 (117,789)	
Maximum Payload Material Density	kg (lb)	62 871 (138,607)	58 771 (129,568)	
Not to Exceed Payload (120% of Target)*	kg (lb)	68 586 (151,207)	64 114 (141,347)	
Not to Exceed Payload Material Density	kg (lb)	114 171 (251,704)	113 426 (250,061)	

*Refer to Caterpillar 10/10/20 Payload Policy.

Sideboards (optional)							
Height		Volume Add		Weight		Maximum (110%) Material Density**	
mm	(in)	m ³	(yd ³)	kg	(lb)	kg	(lb)
155	(6.0)	2.9	(3.8)	430	(948)	1681	(342)

**Based on Quarry Body at 90% Body Volume Fill.

Empty Chassis Weight is figured without fuel.

Payload Calculation: Definitions

Empty Machine Weight = Empty Chassis Weight + Body System Weight

Target Payload = Target Gross Machine Weight less Empty Machine Weight

Maximum Payload = Target Payload × 1.10 (110%)

773G Off-Highway Truck Specifications

10/10/20 Payload Management Policy for Optimal Machine Life

The ideal hauling strategy that maximizes machine and machine component life is to *keep the mean of all payloads at or below the machine's rated target payload.*

- 90% of loads should fall into this range
- No more than 10% of loads should exceed 10% of the target payload
- No loads should be above 20% of the target payload

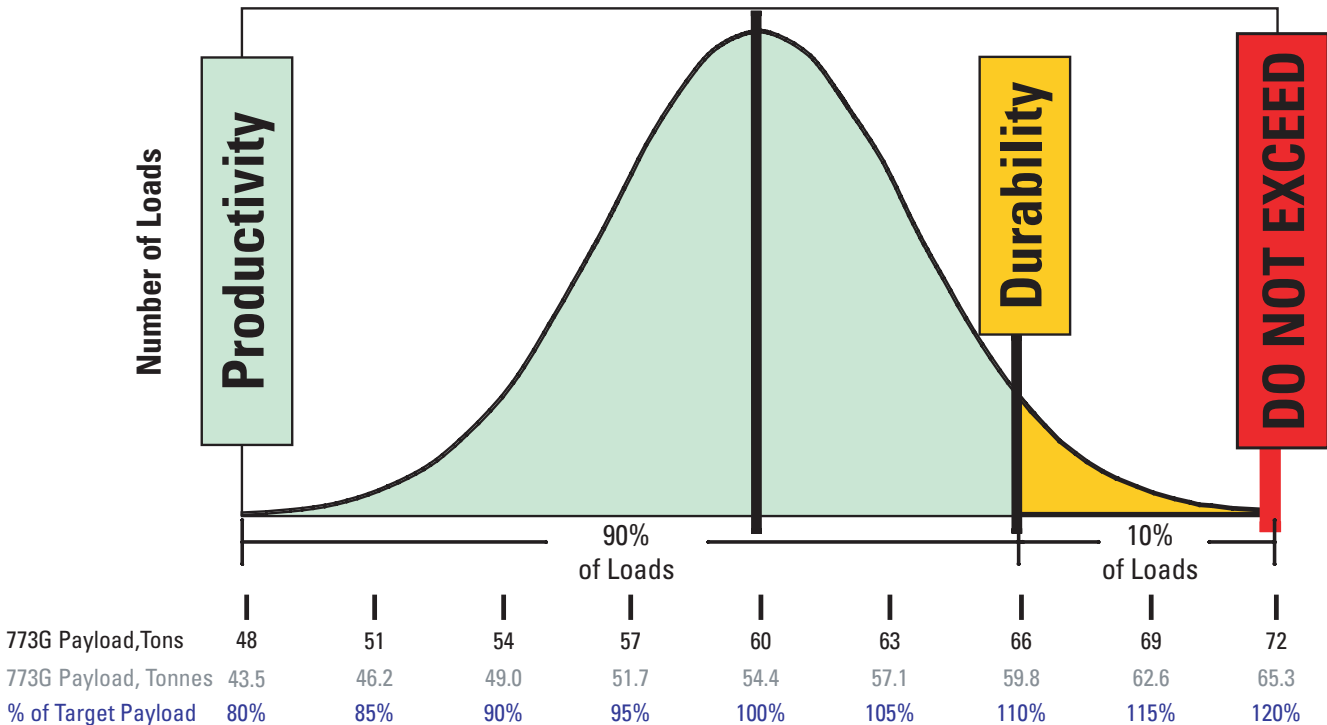

773G Off-Highway Truck Specifications

Dimensions

All dimensions are approximate.

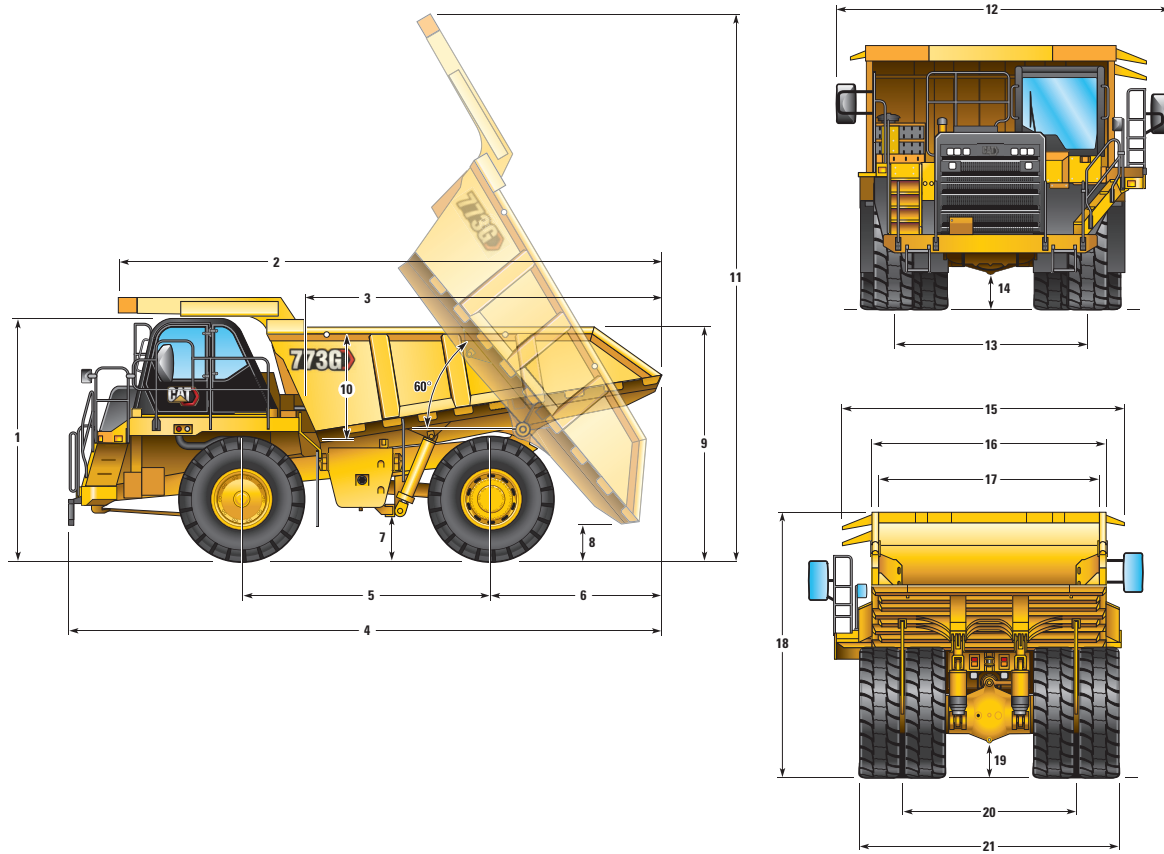

	Dual Slope		Flat Floor	
1 Height to Top of ROPS	4108 mm	13'6"	4108 mm	13'6"
2 Overall Body Length	9216 mm	30'3"	9293 mm	30'6"
3 Inside Body Length	6100 mm	20'0"	6100 mm	20'0"
4 Overall Length	10 070 mm	33'0"	10 146 mm	33'3"
5 Wheelbase	4215 mm	13'10"	4215 mm	13'10"
6 Rear Axle to Tail	2925 mm	9'7"	3006 mm	9'10"
7 Ground Clearance	759 mm	2'6"	759 mm	2'6"
8 Dump Clearance	639 mm	2'1"	640 mm	2'1"
9 Loading Height – Empty	3771 mm	12'4"	3771 mm	12'4"
10 Inside Body Depth – Maximum	1773 mm	5'10"	1727 mm	5'8"
11 Overall Height – Body Raised	9284 mm	30'6"	9280 mm	30'5"
12 Operating Width	5673 mm	18'7"	5673 mm	18'7"
13 Centerline Front Tire Width	3205 mm	10'6"	3205 mm	10'6"
14 Engine Guard Clearance	703 mm	2'4"	703 mm	2'4"
15 Overall Canopy Width	4886 mm	16'0"	4886 mm	16'0"
16 Outside Body Width	3922 mm	12'10"	3922 mm	12'10"
17 Inside Body Width	3654 mm	11'9"	3654 mm	11'9"
18 Front Canopy Height	4459 mm	14'8"	4459 mm	14'8"
19 Rear Axle Clearance	560 mm	1'10"	560 mm	1'10"
20 Centerline Rear Dual Tire Width	2929 mm	9'7"	2929 mm	9'7"
21 Overall Tire Width	4411 mm	14'6"	4411 mm	14'6"

Standard and Optional Equipment

Standard and optional equipment may vary. Consult your Cat dealer for details.

	Standard	Optional		Standard	Optional
POWER TRAIN			OPERATOR ENVIRONMENT (CONTINUED)		
C27 Tier 2 compliant diesel engine: air cleaner with precleaner (2), air-to-air aftercooler (ATAAC), electric start, engine idle shutdown, ether starting aid, exhaust muffler, NGMR radiator	✓		Cab precleaner		✓
Braking system: extended life brakes, automatic retarder control (ARC), manual retarder (utilizes rear oil-cooled, multiple disc brakes), brake release motor (towing), dry disc brakes (front), front brake disconnect switch (front), oil-cooled multiple disc brakes (rear), brake wear indicator (rear), parking brake, secondary brake, service brake	✓		Coat hook	✓	
Cat engine brake		✓	Cup holders (4)	✓	
NOx Reduction System (NRS), Diesel Oxidation Catalyst (DOC); demand fan; MEUI™-C fuel system	✓		Diagnostic connection port, 24V	✓	
Transmission: 7-speed automatic powershift with – Electronic Clutch Pressure Control (ECPC), Advanced Productivity Electronic Control Strategy (APECS); automatic neutral idle, autostall, second gear start	✓		Entertainment radio ready: 5 amp converter, speakers, antenna, wiring harness	✓	
ELECTRICAL			Foot rest	✓	
Alarm, backup	✓		Gauges/indicators: brake oil temperature gauge, coolant temperature gauge, engine overspeed indicator, fuel level, hour meter, speedometer with odometer, tachometer, transmission gear indicator	✓	
Alternator, 120 ampere	✓		Hoist lever	✓	
Autolube power supply ready	✓		Horn	✓	
Batteries, maintenance-free, 12V (2), 1,400 CCA combined	✓		Light: courtesy, dome	✓	
Electrical system, 25 amp, 24V to 12V converter	✓		Lights – HID		✓
Lighting system: backup light (halogen), directional signals/hazard warning (front and rear LED), engine compartment light, headlights (halogen) with dimmer, operator access courtesy lights, side profile lights, stop/tail lights (LED)	✓		Mirrors: convex, heated		✓
Service center containing: battery jump start, breakers with spare fuses, lockout switch, ports – ET and Advanced Health, service lockout switch (power without engine start)	✓		Mirrors, non-heated	✓	
OPERATOR ENVIRONMENT			Power port, 24V and 12V (2)	✓	
Advisor display: air cleaner service indicator, fluid level monitoring, fuel level monitoring, display languages (market based)	✓		Rollover Protection (ROPS)/ Falling Object Protection (FOPS)	✓	
Air conditioning/heat	✓		Seat, Cat Comfort Series III: full air suspension, retractable 3-point seat belt with shoulder harness	✓	
Ashtray and cigarette lighter	✓		Seat, training with lap belt	✓	
Automatic temperature control	✓		Steering wheel, padded, tilt and telescopic	✓	
			Storage compartment	✓	
			Sun visor	✓	
			Throttle lock	✓	
			Visibility package (meets ISO 5006 requirements)		✓
			Window, hinged, right side (emergency exit)	✓	
			Window, powered, left side	✓	
			Windshield wiper, intermittent, and washer	✓	
			Work Area Vision System (WAVS)		✓
			TECHNOLOGY PRODUCTS		
			Economy Modes, standard and adaptive	✓	
			Product Link™, cellular or satellite	✓	
			Traction Control System (TCS)	✓	
			Truck Production Management System	✓	
			Advanced Health	✓	

Standard and Optional Equipment

Standard and optional equipment may vary. Consult your Cat dealer for details.

OTHER		OTHER (CONTINUED)	
Antifreeze	✓	Ground-level engine shutdown	✓
Body heat	✓	Ground-level grease fittings	✓
Body liner	✓	Grouped ground-level filters	✓
Body sideboards	✓	Operator Maintenance Manual (OMM)	✓
Body down indicator	✓	Rims 17 × 35	✓
Body safety pin (secures body in up position)	✓	Rock ejectors	✓
Center-mounted rims	✓	Secondary steering (electric)	✓
Clustered grease fittings	✓	Spare rim	✓
Cold weather packages	✓	Suspension, front and rear (EU compliant)	✓
Driveline guards	✓	Tie down eyes	✓
Engine crankcase guards	✓	Tow hooks, front/tow pin, rear	✓
Extended life coolant to -34°C (-30°F)	✓	Wheel chocks	✓
Fan guards	✓	Vandalism protection locks	✓
Fluid fill service center	✓		
Fuel tank, 795 L (210 gal)	✓		
Ground-level battery disconnect	✓		

For more complete information on Cat products, dealer services, and industry solutions, visit us on the web at www.cat.com.

Materials and specifications are subject to change without notice. Featured machines in photos may include additional equipment. See your Cat dealer for available options.

© 2022 Caterpillar. All Rights Reserved. CAT, CATERPILLAR, LET'S DO THE WORK, their respective logos, MEUI, Product Link, "Caterpillar Corporate Yellow", the "Power Edge" and Cat "Modern Hex" trade dress as well as corporate and product identity used herein, are trademarks of Caterpillar and may not be used without permission.

AEXQ3409-00 (1-2022)
(Afr-ME, CIS, S Am, China,
Aus-NZ, SE Asia)

