



Cat[®] Hammers

Performance Models

Technical Specifications

Not all attachments are available in all regions. Consult your Cat[®] dealer for specific configurations available in your region.

Table of Contents

Specifications	2				
Hydraulic Specifications	3				
Dimensions	4				
Hammer Tool Specifications	5				
Matching	7				
311F.....7	318D229	326D257	336 GC.....82	355.....96	M318.....143
312D27	318F.....30	326F.....57	336.....83	374F.....97	M319.....174
312 GC.....8	320D2 GC30	326 GC.....58	340D284	374.....97	M320D2.....179
313D28	320D231	326.....59	340F.....85	390F.....98	M320F.....181
313D2 LGP9	320F.....32	330D265	340F UHD86	395.....98	M320.....185
313F GC.....9	320 GC.....33	330F.....66	340.....88	M314F.....100	M322D2.....204
313F.....10	320 GX.....34	330 GC.....67	340 UHD88	M314.....104	M322F.....211
313 GC.....13	320.....34	330.....68	345 GC.....90	M315D2.....111	M322.....214
313.....14	323D235	333.....71	349D291	M315F.....114	M322D2 MH...220
315F CR.....17	323F.....36	335F CR.....72	349F.....92	M315.....116	M324D2 MH...220
315 GC.....18	323 GC.....37	335.....73	349F XE.....92	M316F.....120	MH3022.....221
315.....19	323 GX.....38	336D2 GC77	349.....93	M316.....128	MH3024.....226
316F.....21	323.....39	336D277	352F.....93	M317D2.....131	MH3026.....232
316 GC.....22	325F CR.....47	336D2 XE.....78	352F XE.....94	M317F.....133	
317 GC.....23	325.....48	336F.....78	352.....94	M317.....134	
317.....25	325 Tunneling...54	336F XE.....80	352 UHD96	M318F.....135	
Additional Options	235				
Autolube	236				

Hammer Technical Specifications

Specifications

Model	Part No.	Linkage	Carrier Weight, Minimum		Carrier Weight, Maximum		Operating Weight, Minimum		Operating Weight, Maximum	
			t	lb	t	lb	kg	lb	kg	lb
H110 S Top-mount	355-3817		11	24300	18	39700	950	2090	1080	2376
	385-0326		11	24300	18	39700	950	2090	1080	2376
	388-4794		11	24300	18	39700	950	2090	1080	2376
H115 S Top-mount	355-7065	B, CB	12	26500	20	44100	1070	2354	1460	3212
	385-0328	B, CB	12	26500	20	44100	1070	2354	1460	3212
	388-4795	B, CB	12	26500	20	44100	1070	2354	1460	3212
H120 S Top-mount	355-7061	B, CB, DB	16	35300	27	59500	1480	3256	1860	4092
	385-0329	B, CB, DB	16	35300	27	59500	1480	3256	1860	4092
	388-4796	B, CB, DB	16	35300	27	59500	1480	3256	1860	4092
H130 S Top-mount	355-7063	B, CB, DB	18	39700	36	79400	1750	3850	2140	4708
	385-0330	B, CB, DB	18	39700	36	79400	1750	3850	2140	4708
	388-4797	B, CB, DB	18	39700	36	79400	1750	3850	2140	4708
H140 S Top-mount	363-0738	CB, DB, TB	24	52900	42	92600	2410	5302	2660	5852
	426-4892	CB, DB, TB	24	52900	42	92600	2410	5302	2660	5852
	431-0575	CB, DB, TB	24	52900	42	92600	2410	5302	2660	5852
	431-0581	CB, DB, TB	24	52900	42	92600	2410	5302	2660	5852
H160 S Top-mount	366-5119	DB, TB, UB	32	70600	55	121300	3230	7106	3530	7766
	426-4894	DB, TB, UB	32	70600	55	121300	3230	7106	3530	7766
	431-0578	DB, TB, UB	32	70600	55	121300	3230	7106	3530	7766
	431-0584	DB, TB, UB	32	70600	55	121300	3230	7106	3530	7766
H180 S Top-mount	366-5168	TB, UB, VB/VB2	42	92610	76	167580	3990	8778	4340	9548
	426-4896	TB, UB, VB/VB2	42	92610	76	167580	3990	8778	4340	9548
	431-0580	TB, UB, VB/VB2	42	92610	76	167580	3990	8778	4340	9548
	431-0589	TB, UB, VB/VB2	42	92610	76	167580	3990	8778	4340	9548
H190 S Top-mount	570-5968	TB, UB, VB2/WB2, CW55, CW70	43	94798	80	176368	5200	11440	5650	12430
H215 S Top-mount	570-6109	VB2, WB2, HB2, JC, CW70	65	143299	120	264552	7400	16280	7650	16830

Hydraulic Specifications

Model	Part No.	E Snergy Class		Blows Per Minute		Rated Flow, Minimum		Rated Flow, Maximum		Operating Pressure, Minimum		Operating Pressure, Maximum		Sound Level
		J	ft-lb	Minimum	Maximum	lpm	gpm	lpm	gpm	kPa	psi	kPa	psi	
H110 S Top-mount	355-3817	2712	2000	450	1000	60	15.9	120	31.7	13000	1885	16000	2320	118
	385-0326	2712	2000	450	1000	60	15.9	120	31.7	13000	1885	16000	2320	118
	388-4794	2712	2000	450	1000	60	15.9	120	31.7	13000	1885	16000	2320	118
H115 S Top-mount	355-7065	4067	3000	370	800	70	18.5	130	34.4	13000	1885	15000	2175	117
	385-0328	4067	3000	370	800	70	18.5	130	34.4	13000	1885	15000	2175	117
	388-4795	4067	3000	370	800	70	18.5	130	34.4	13000	1885	15000	2175	117
H120 S Top-mount	355-7061	4745	3500	350	620	100	26.5	170	45.0	13000	1885	15000	2175	118
	385-0329	4745	3500	350	620	100	26.5	170	45.0	13000	1885	15000	2175	118
	388-4796	4745	3500	350	620	100	26.5	170	45.0	13000	1885	15000	2175	118
H130 S Top-mount	355-7063	6101	4500	320	600	120	31.7	220	58.2	13000	1885	15000	2175	120
	385-0330	6101	4500	320	600	120	31.7	220	58.2	13000	1885	15000	2175	120
	388-4797	6101	4500	320	600	120	31.7	220	58.2	13000	1885	15000	2175	120
H140 S Top-mount	363-0738	8135	6000	325	540	160	42.3	230	60.8	13000	1885	16000	2320	120
	426-4892	8135	6000	325	540	160	42.3	230	60.8	13000	1885	16000	2320	120
	431-0575	8135	6000	325	540	160	42.3	230	60.8	13000	1885	16000	2320	120
	431-0581	8135	6000	325	540	160	42.3	230	60.8	13000	1885	16000	2320	120
H160 S Top-mount	366-5119	11524	8500	400	505	220	58.2	300	79.4	13000	1885	16000	2320	126
	426-4894	11524	8500	400	505	220	58.2	300	79.4	13000	1885	16000	2320	126
	431-0578	11524	8500	400	505	220	58.2	300	79.4	13000	1885	16000	2320	126
	431-0584	11524	8500	400	505	220	58.2	300	79.4	13000	1885	16000	2320	126
H180 S Top-mount	366-5168	16270	12000	275	450	220	58.2	300	79.4	13000	1885	16000	2320	126
	426-4896	16270	12000	275	450	220	58.2	300	79.4	13000	1885	16000	2320	126
	431-0580	16270	12000	275	450	220	58.2	300	79.4	13000	1885	16000	2320	126
	431-0589	16270	12000	275	450	220	58.2	300	79.4	13000	1885	16000	2320	126
H190 S Top-mount	570-5968	17727	13000	370	530	280	74.1	380	100.5	15000	2175	16000	2320	128
H215 S Top-mount	570-6109	24407	18000	300	520	360	95.2	460	121.7	17000	2465	18000	2610	131

Hammer Technical Specifications

Dimensions

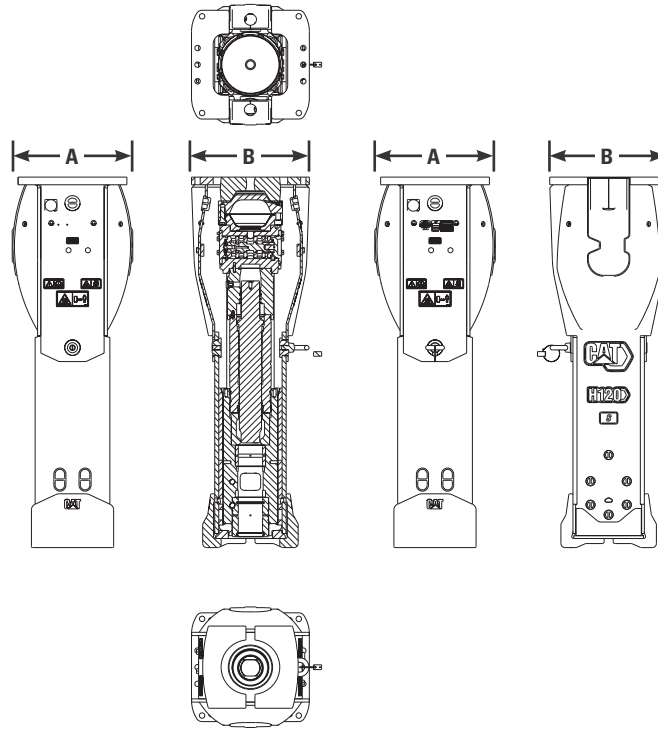

Model	Part No.	(A) Width		(B) Length, Top		Height	
		mm	in	mm	in	mm	in
H110 S Top-mount	355-3817	555	21.85	585	23.03	2024	79.69
	385-0326	555	21.85	585	23.03	2024	79.69
	388-4794	555	21.85	585	23.03	2024	79.69
H115 S Top-mount	355-7065	555	21.85	585	23.03	2191	86.26
	385-0328	555	21.85	585	23.03	2191	86.26
	388-4795	555	21.85	585	23.03	2191	86.26
H120 S Top-mount	355-7061	578	22.76	585	23.03	2372	93.39
	385-0329	578	22.76	585	23.03	2372	93.39
	388-4796	578	22.76	585	23.03	2372	93.39
H130 S Top-mount	355-7063	627	24.69	585	23.03	2560	100.79
	385-0330	627	24.69	585	23.03	2560	100.79
	388-4797	627	24.69	585	23.03	2560	100.79
H140 S Top-mount	363-0738	670	26.38	585	23.03	2759	108.62
	426-4892	670	26.38	585	23.03	2759	108.62
	431-0575	670	26.38	585	23.03	2759	108.62
H160 S Top-mount	431-0581	670	26.38	585	23.03	2759	108.62
	366-5119	736	28.98	730	28.74	3057	120.35
	426-4894	736	28.98	730	28.74	3057	120.35
	431-0578	736	28.98	730	28.74	3057	120.35
H180 S Top-mount	431-0584	736	28.98	730	28.74	3057	120.35
	366-5168	758	29.84	730	28.74	3257	128.23
	426-4896	758	29.84	730	28.74	3257	128.23
	431-0580	758	29.84	730	28.74	3257	128.23
H190 S Top-mount	431-0589	758	29.84	730	28.74	3257	128.23
H190 S Top-mount	570-5968	934	36.77	840	33.07	3329	131.06
H215 S Top-mount	570-6109	1101	43.35	1050	41.34	3707	145.94

Hammer Technical Specifications

Hammer Tool Specifications

Hammer Model	Tool Family	Tool Subfamily	Part No.	Total Length		Working Length		Diameter, Top		Diameter, Bottom		Weight	
				mm	in	mm	in	mm	in	mm	in	kg	lb
H110 S	Standard	Blunt	355-5887	890	35.04	496.0	19.53	99.5	3.92	99.5	3.92	53.1	117.07
	Standard	Chisel	355-5882	890	35.04	496.0	19.53	99.5	3.92	99.5	3.92	50.4	111.11
	Standard	Moil	355-5884	890	35.04	496.0	19.53	99.5	3.92	99.5	3.92	50.2	110.67
	Specialty	Long Chisel	373-4914	1000	39.37	606.0	23.86	99.5	3.92	99.5	3.92	57.1	125.88
	Specialty	Long Moil	373-4916	1000	39.37	606.0	23.86	99.5	3.92	99.5	3.92	56.9	125.44
	WearFlex	Blunt	468-8005	890	35.04	496.0	19.53	99.5	3.92	99.5	3.92	53.2	117.29
	WearFlex	Chisel	468-8031	890	35.04	496.0	19.53	99.5	3.92	99.5	3.92	50.4	111.11
	WearFlex	Moil	468-8013	890	35.04	496.0	19.53	99.5	3.92	99.5	3.92	50.3	110.89
H115 S	Standard	Blunt	355-5880	980	38.58	549.0	21.61	109.5	4.31	109.5	4.31	69.6	153.44
	Standard	Chisel	355-5878	980	38.58	549.0	21.61	109.5	4.31	109.5	4.31	65.8	145.06
	Standard	Moil	355-5879	980	38.58	549.0	21.61	109.5	4.31	109.5	4.31	65.7	144.84
	Specialty	Long Chisel	373-4917	1080	42.52	649.0	25.55	109.5	4.31	109.5	4.31	73.2	161.38
	Specialty	Long Moil	373-4918	1080	42.52	649.0	25.55	109.5	4.31	109.5	4.31	73.0	160.94
	WearFlex	Blunt	468-8006	980	38.58	549.0	21.61	109.5	4.31	109.5	4.31	69.7	153.66
	WearFlex	Chisel	468-8032	980	38.58	549.0	21.61	109.5	4.31	109.5	4.31	65.9	145.28
	WearFlex	Moil	468-8014	980	38.58	549.0	21.61	109.5	4.31	109.5	4.31	65.7	144.84
H120 S	Standard	Blunt	355-5867	1075	42.32	597.0	23.50	119.5	4.70	119.5	4.70	91.6	201.94
	Standard	Chisel	355-5865	1075	42.32	597.0	23.50	119.5	4.70	119.5	4.70	86.3	190.26
	Standard	Moil	355-5866	1075	42.32	597.0	23.50	119.5	4.70	119.5	4.70	86.2	190.04
	Specialty	Long Chisel	373-4919	1175	46.26	697.0	27.44	119.5	4.70	119.5	4.70	95.1	209.66
	Specialty	Long Moil	373-4920	1175	46.26	697.0	27.44	119.5	4.70	119.5	4.70	95.0	209.44
	WearFlex	Blunt	468-8007	1075	42.32	597.0	23.50	119.5	4.70	119.5	4.70	91.6	201.94
	WearFlex	Chisel	468-8033	1075	42.32	597.0	23.50	119.5	4.70	119.5	4.70	86.4	190.48
	WearFlex	Moil	468-8017	1075	42.32	597.0	23.50	119.5	4.70	119.5	4.70	86.3	190.26
H130 S	Standard	Blunt	355-5877	1150	45.28	646.6	25.46	130.0	5.12	130.0	5.12	115.3	254.19
	Standard	Chisel	355-5868	1150	45.28	646.6	25.46	130.0	5.12	130.0	5.12	108.4	238.98
	Standard	Moil	355-5876	1150	45.28	646.6	25.46	130.0	5.12	130.0	5.12	108.2	238.54
	Specialty	Hard Rock Chisel	373-4923	1150	45.28	646.6	25.46	130.0	5.12	129.5	5.10	104.7	230.82
	Specialty	Long Chisel	373-4921	1250	49.21	746.6	29.39	130.0	5.12	129.5	5.10	118.7	261.69
	Specialty	Long Moil	373-4922	1250	49.21	746.6	29.39	130.0	5.12	129.5	5.10	118.5	261.25
	WearFlex	Blunt	468-8008	1150	45.28	646.6	25.46	130.0	5.12	130.0	5.12	115.4	254.41
	WearFlex	Chisel	468-8034	1150	45.28	646.6	25.46	130.0	5.12	130.0	5.12	108.5	239.20
	WearFlex	Moil	468-8021	1150	45.28	646.6	25.46	130.0	5.12	130.0	5.12	108.3	238.76
H140 S	Standard	Blunt	374-3622	1200	47.24	651.8	25.66	139.5	5.49	139.5	5.49	140.0	308.65
	Standard	Chisel	374-3620	1200	47.24	651.8	25.66	139.5	5.49	139.5	5.49	131.0	288.81
	Standard	Moil	374-3621	1200	47.24	651.8	25.66	139.5	5.49	139.5	5.49	130.3	287.26
	Specialty	Hard Rock Chisel	423-1654	1200	47.24	651.8	25.66	139.5	5.49	139.5	5.49	127.3	280.65
	Specialty	Long Chisel	423-1659	1350	53.15	801.8	31.57	139.5	5.49	139.5	5.49	149.1	328.71
	Specialty	Long Moil	423-1660	1350	53.15	801.8	31.57	139.5	5.49	139.5	5.49	149.2	328.93
	Specialty	Super Blunt	423-1662	1250	49.21	701.8	27.63	139.5	5.49	150.0	5.91	157.4	347.01
	WearFlex	Blunt	468-8010	1200	47.24	651.8	25.66	139.5	5.49	139.5	5.49	140.1	308.87
	WearFlex	Chisel	468-8035	1200	47.24	651.8	25.66	139.5	5.49	139.5	5.49	131.2	289.25
	WearFlex	Moil	468-8023	1200	47.24	651.8	25.66	139.5	5.49	139.5	5.49	131.2	289.25

(continued on next page)

Hammer Technical Specifications

Hammer Tool Specifications (continued)

Hammer Model	Tool Family	Tool Subfamily	Part No.	Total Length		Working Length		Diameter, Top		Diameter, Bottom		Weight	
				mm	in	mm	in	mm	in	mm	in	kg	lb
H160 S	Standard	Blunt	374-3625	1400	55.12	753.0	29.65	155.5	6.12	159.5	6.28	211.0	465.17
	Standard	Chisel	374-3623	1400	55.12	753.0	29.65	155.5	6.12	159.5	6.28	196.8	433.87
	Standard	Moil	374-3624	1400	55.12	753.0	29.65	155.5	6.12	159.5	6.28	197.6	435.63
	Specialty	Hard Rock Chisel	423-1663	1400	55.12	753.0	29.65	155.5	6.12	159.5	6.28	190.9	420.86
	Specialty	Long Chisel	423-1664	1530	60.24	883.0	34.76	155.5	6.12	159.5	6.28	217.2	478.84
	Specialty	Long Moil	423-1665	1530	60.24	883.0	34.76	155.5	6.12	159.5	6.28	218.0	480.61
	Specialty	Super Blunt	423-1667	1450	57.09	803.0	31.61	155.5	6.12	175.0	6.89	241.7	532.86
	WearFlex	Blunt	468-8011	1400	55.12	753.0	29.65	155.5	6.12	159.5	6.28	211.0	465.17
	WearFlex	Chisel	468-8036	1400	55.12	753.0	29.65	155.5	6.12	159.5	6.28	196.8	433.87
	WearFlex	Moil	468-8029	1400	55.12	753.0	29.65	155.5	6.12	159.5	6.28	197.6	435.63
H180 S	Standard	Blunt	374-3629	1500	59.06	760.5	29.94	174.5	6.87	179.5	7.07	287.1	632.95
	Standard	Chisel	374-3626	1500	59.06	760.5	29.94	174.5	6.87	179.5	7.07	266.2	586.87
	Standard	Moil	374-3627	1500	59.06	760.5	29.94	174.5	6.87	179.5	7.07	268.3	591.50
	Specialty	Hard Rock Chisel	423-1668	1500	59.06	760.5	29.94	174.5	6.87	179.5	7.07	257.7	568.13
	Specialty	Super Blunt	423-1669	1550	61.02	810.5	31.91	174.5	6.87	202.0	7.95	335.0	738.55
	WearFlex	Blunt	468-8012	1500	59.06	760.5	29.94	174.5	6.87	179.5	7.07	287.1	632.95
	WearFlex	Chisel	468-8038	1500	59.06	760.5	29.94	174.5	6.87	179.5	7.07	266.2	586.87
	WearFlex	Moil	468-8030	1500	59.06	760.5	29.94	174.5	6.87	179.5	7.07	268.3	591.50
H190 S	Standard	Blunt	570-6095	1400	55.12	454.0	17.87	190.0	7.48	190.0	7.48	293.0	646.07
	Standard	Chisel	570-6097	1550	61.02	604.0	23.78	190.0	7.48	190.0	7.48	303.0	668.12
	Specialty	Chisel (Hard Rock)	570-6099	1550	61.02	604.0	23.78	190.0	7.48	190.0	7.48	289.0	637.25
	Specialty	Chisel (Limestone)	570-6100	1550	61.02	604.0	23.78	190.0	7.48	190.0	7.48	313.0	690.17
	Standard	Moil	570-6096	1550	61.02	604.0	23.78	190.0	7.48	190.0	7.48	297.0	654.89
	Standard	Pyramidal	570-6098	1550	61.02	604.0	23.78	190.0	7.48	190.0	7.48	295.0	650.48
	Specialty	Super Blunt	570-6101	1400	55.12	454.0	17.87	190.0	7.48	197.0	7.76	308.0	679.14
H215 S	Standard	Blunt	570-6222	1600	62.99	537.0	21.14	215.0	8.46	215.0	8.46	431.0	950.36
	Standard	Chisel	570-6220	1750	68.90	687.0	27.05	215.0	8.46	215.0	8.46	442.0	974.61
	Specialty	Chisel (Hard Rock)	570-6224	1750	68.90	687.0	27.05	215.0	8.46	215.0	8.46	422.0	930.51
	Specialty	Chisel (Limestone)	570-6225	1750	68.90	687.0	27.05	215.0	8.46	215.0	8.46	455.0	1003.28
	Standard	Moil	570-6221	1750	68.90	687.0	27.05	215.0	8.46	215.0	8.46	432.0	952.56
	Standard	Pyramidal	570-6223	1750	68.90	687.0	27.05	215.0	8.46	215.0	8.46	432.0	952.56

Matching – Tracked Excavators

Match
 Working Range Front Only
 Allowed Usage on Machine Less Than 50%
 No Match

311F

Pin-on

Undercarriage	L	
Counterweight	—	
Boom Type	Reach	
Stick Length	2.25 m (7'5")	2.80 m (9'2")
H110 S	✓	✓
H115 S	✓	✓

Cat® Pin Grabber Coupler

Undercarriage	L	
Counterweight	—	
Boom Type	Reach	
Stick Length	2.25 m (7'5")	2.80 m (9'2")
H110 S	✓	✓
H115 S	✓	

CW-20 S Dedicated Coupler

Undercarriage	L
Counterweight	—
Boom Type	Reach
Stick Length	2.25 m (7'5")
H110 S	✓
H115 S	✓

CW-20 Dedicated Coupler

Undercarriage	—				
Counterweight	—				
Boom Type	Reach			VA	
Stick Length	2.10 m (6'11")	2.50 m (8'2")	3.00 m (9'10")	2.10 m (6'11")	2.50 m (8'2")
H110 S	✓	✓	✓	✓	✓
H115 S	✓	✓	✓		

CW-20 Dedicated Coupler (continued)

Undercarriage	L				
Counterweight	—				
Boom Type	Reach			VA	
Stick Length	2.10 m (6'11")	2.50 m (8'2")	3.00 m (9'10")	2.10 m (6'11")	2.50 m (8'2")
H110 S	✓	✓	✓	✓	✓
H115 S	✓	✓	✓		

312D2

Pin-on

Undercarriage	—		L	
Counterweight	—		—	
Boom Type	Reach		Reach	
Stick Length	2.50 m (8'2")	3.00 m (9'10")	2.50 m (8'2")	3.00 m (9'10")
H110 S	✓	✓	✓	✓
H115 S	✓	✓	✓	✓

(continued on next page)

Hammer Technical Specifications

Matching – Tracked Excavators *(continued)*

Match
 * Working Range Front Only
 † Allowed Usage on Machine Less Than 50%
 No Match

312D2 *(continued)*

Cat Pin Grabber Coupler

Undercarriage	—		L	
Counterweight	—		—	
Boom Type	Reach		Reach	
Stick Length	2.50 m (8'2")	3.00 m (9'10")	2.50 m (8'2")	3.00 m (9'10")
H110 S	✓	✓	✓	✓
H115 GC	✓*		✓	
H115 GC S	✓		✓	✓*
H115 S	✓	✓	✓	✓

CW-20 S Dedicated Coupler

Undercarriage	L
Counterweight	—
Boom Type	Reach
Stick Length	2.50 m (8'2")
H110 S	✓
H115 S	✓

CW-20 Dedicated Coupler

Undercarriage	L
Counterweight	—
Boom Type	Reach
Stick Length	2.50 m (8'2")
H110 S	✓
H115 S	✓

312 GC

Pin-on

Undercarriage	S
Counterweight	1.8 mt/ T3, NR3, NR4
Boom Type	Reach (4.3 m)
Stick Length	2.25 m (7'5")
H110 S	✓
H115 S	✓

313D2

Pin-on

Undercarriage	—	L
Counterweight	—	—
Boom Type	Reach HD	Reach HD
Stick Length	2.50 m HD (8'2")	2.50 m HD (8'2")
H110 S	✓	✓
H115 S	✓	✓

(continued on next page)

Matching – Tracked Excavators *(continued)*

Match
 Working Range Front Only
 Allowed Usage on Machine Less Than 50%
 No Match

313D2 *(continued)*

Cat Pin Grabber Coupler

Undercarriage	—	L
Counterweight	—	—
Boom Type	Reach HD	Reach HD
Stick Length	2.50 m HD (8'2")	2.50 m HD (8'2")
H110 S	✓	✓
H115 S	✓	✓

CW-20 S Dedicated Coupler

Undercarriage	L
Counterweight	—
Boom Type	Reach HD
Stick Length	2.50 m HD (8'2")
H110 S	✓
H115 S	✓

CW-20 Dedicated Coupler

Undercarriage	L
Counterweight	—
Boom Type	Reach HD
Stick Length	2.50 m HD (8'2")
H110 S	✓
H115 S	✓

313D2 LGP

Pin-on

Undercarriage	L	
Counterweight	—	
Boom Type	Reach HD	
Stick Length	2.50 m HD (8'2")	3.00 m (9'10")
H110 S	✓	✓
H115 S	✓	✓

313F GC

Pin-on

Undercarriage	L		L with Blade	
Counterweight	—		—	
Boom Type	Reach		Reach	
Stick Length	2.50 m (8'2")	3.00 m (9'10")	2.50 m (8'2")	3.00 m (9'10")
H110 S	✓	✓	✓	✓
H115 S	✓	✓	✓	✓

Cat Pin Grabber Coupler

Undercarriage	L		L with Blade	
Counterweight	—		—	
Boom Type	Reach		Reach	
Stick Length	2.50 m (8'2")	3.00 m (9'10")	2.50 m (8'2")	3.00 m (9'10")
H110 S	✓	✓	✓	✓
H115 S	✓	✓	✓	✓

(continued on next page)

Hammer Technical Specifications

Matching – Tracked Excavators *(continued)*

Match
 * Working Range Front Only
 † Allowed Usage on Machine Less Than 50%
 No Match

313F GC *(continued)*

CW-20 S Dedicated Coupler

Undercarriage	L		L with Blade	
Counterweight	—		—	
Boom Type	Reach		Reach	
Stick Length	2.50 m (8'2")	3.00 m (9'10")	2.50 m (8'2")	3.00 m (9'10")
H110 S	✓	✓	✓	✓
H115 S	✓	✓	✓	✓

CW-20 Dedicated Coupler

Undercarriage	L		L with Blade	
Counterweight	—		—	
Boom Type	Reach		Reach	
Stick Length	2.50 m (8'2")	3.00 m (9'10")	2.50 m (8'2")	3.00 m (9'10")
H110 S	✓	✓	✓	✓
H115 S	✓	✓	✓	✓

313F

Pin-on

Undercarriage	—				
Counterweight	—				
Boom Type	Reach			VA	
Stick Length	2.10 m (6'11")	2.50 m (8'2")	3.00 m (9'10")	2.10 m (6'11")	2.50 m (8'2")
H110 S	✓	✓	✓	✓	✓
H115 S	✓	✓	✓	✓	

Pin-on *(continued)*

Undercarriage	L						
Counterweight	—						
Boom Type	Reach					VA	
Stick Length	2.10 m (6'11")	2.50 m (8'2")	2.80 m (9'2")	3.00 m (9'10")	3.00 m TR (9'10")	2.10 m (6'11")	2.50 m (8'2")
H110 S	✓	✓	✓	✓	✓	✓	✓
H115 S	✓	✓	✓	✓	✓	✓	

Cat Pin Grabber Coupler

Undercarriage	—				
Counterweight	—				
Boom Type	Reach			VA	
Stick Length	2.10 m (6'11")	2.50 m (8'2")	3.00 m (9'10")	2.10 m (6'11")	2.50 m (8'2")
H110 S	✓	✓	✓	✓	✓
H115 S	✓	✓	✓		

Cat Pin Grabber Coupler *(continued)*

Undercarriage	L						
Counterweight	—						
Boom Type	Reach					VA	
Stick Length	2.10 m (6'11")	2.50 m (8'2")	2.80 m (9'2")	3.00 m (9'10")	3.00 m TR (9'10")	2.10 m (6'11")	2.50 m (8'2")
H110 S	✓	✓	✓	✓	✓	✓	✓
H115 S	✓	✓	✓	✓	✓		

(continued on next page)

Matching – Tracked Excavators *(continued)*

Match
 Working Range Front Only
 Allowed Usage on Machine Less Than 50%
 No Match

313F *(continued)*

CW-20 S Dedicated Coupler

Undercarriage	—				L			
Counterweight	—				—			
Boom Type	Reach			VA	Reach			VA
Stick Length	2.10 m (6'11")	2.50 m (8'2")	3.00 m (9'10")	2.10 m (6'11")	2.10 m (6'11")	2.50 m (8'2")	3.00 m (9'10")	2.10 m (6'11")
H110 S	✓	✓	✓	✓	✓	✓	✓	✓
H115 S	✓	✓	✓		✓	✓	✓	

S60 Dedicated Coupler

Undercarriage	—				
Counterweight	—				
Boom Type	Reach			VA	
Stick Length	2.10 m (6'11")	2.50 m (8'2")	3.00 m (9'10")	2.10 m (6'11")	2.50 m (8'2")
H110 S	✓	✓	✓	✓	✓
H115 S	✓	✓	✓	✓	

S60 Dedicated Coupler *(continued)*

Undercarriage	L				
Counterweight	—				
Boom Type	Reach			VA	
Stick Length	2.10 m (6'11")	2.50 m (8'2")	3.00 m (9'10")	2.10 m (6'11")	2.50 m (8'2")
H110 S	✓	✓	✓	✓	✓
H115 S	✓	✓	✓	✓	

HCS60 Dedicated Coupler

Undercarriage	—				
Counterweight	—				
Boom Type	Reach			VA	
Stick Length	2.10 m (6'11")	2.50 m (8'2")	3.00 m (9'10")	2.10 m (6'11")	2.50 m (8'2")
H110 S	✓	✓	✓	✓	✓
H115 S	✓	✓	✓	✓	✓

HCS60 Dedicated Coupler *(continued)*

Undercarriage	L				
Counterweight	—				
Boom Type	Reach			VA	
Stick Length	2.10 m (6'11")	2.50 m (8'2")	3.00 m (9'10")	2.10 m (6'11")	2.50 m (8'2")
H110 S	✓	✓	✓	✓	✓
H115 S	✓	✓	✓	✓	✓

HCS65 Dedicated Coupler

Undercarriage	—				
Counterweight	—				
Boom Type	Reach			VA	
Stick Length	2.10 m (6'11")	2.50 m (8'2")	3.00 m (9'10")	2.10 m (6'11")	2.50 m (8'2")
H110 S	✓	✓	✓	✓	✓
H115 S	✓	✓	✓	✓	✓

(continued on next page)

Hammer Technical Specifications

Matching – Tracked Excavators (continued)

Match
 * Working Range Front Only
 † Allowed Usage on Machine Less Than 50%
 No Match

313F (continued)

HCS65 Dedicated Coupler (continued)

Undercarriage	L				
Counterweight	—				
Boom Type	Reach			VA	
Stick Length	2.10 m (6'11")	2.50 m (8'2")	3.00 m (9'10")	2.10 m (6'11")	2.50 m (8'2")
H110 S	✓	✓	✓	✓	✓
H115 S	✓	✓	✓	✓	✓

Tilt-Rotator TRS10 with CW20s Dedicated Coupler

Undercarriage	—		L	
Counterweight	—		—	
Boom Type	Reach		Reach	
Stick Length	2.10 m (6'11")	2.50 m (8'2")	2.10 m (6'11")	2.50 m (8'2")
H110 S	✓	✓	✓	✓

Tilt-Rotator TRS10 with CW20 Dedicated Coupler

Undercarriage	—		L	
Counterweight	—		—	
Boom Type	Reach		Reach	
Stick Length	2.10 m (6'11")	2.50 m (8'2")	2.10 m (6'11")	2.50 m (8'2")
H110 S	✓	✓	✓	✓

Tilt-Rotator TRS10 with S60 Dedicated Coupler

Undercarriage	—			L				
Counterweight	—			—				
Boom Type	Reach			Reach				
Stick Length	2.10 m (6'11")	2.50 m (8'2")	3.00 m (9'10")	2.10 m (6'11")	2.50 m (8'2")	2.80 m (9'2")	3.00 m (9'10")	3.00 m TR (9'10")
H110 S	✓	✓	✓	✓	✓	✓	✓	✓

S60 – Tilt-Rotator TRS10 – S60

Undercarriage	—		L		
Counterweight	—		—		
Boom Type	Reach		Reach		
Stick Length	2.10 m (6'11")	2.50 m (8'2")	2.10 m (6'11")	2.50 m (8'2")	3.00 m (9'10")
H110 S	✓	✓	✓	✓	✓

Tilt-Rotator TRS10 with HCS60 Dedicated Coupler

Undercarriage	—			L		
Counterweight	—			—		
Boom Type	Reach			Reach		
Stick Length	2.10 m (6'11")	2.50 m (8'2")	3.00 m (9'10")	2.10 m (6'11")	2.50 m (8'2")	3.00 m (9'10")
H110 S	✓	✓	✓	✓	✓	✓

HCS60 – Tilt-Rotator TRS10 – HCSS60

Undercarriage	—		L	
Counterweight	—		—	
Boom Type	Reach		Reach	
Stick Length	2.10 m (6'11")	2.50 m (8'2")	2.10 m (6'11")	2.50 m (8'2")
H110 S	✓	✓	✓	✓

(continued on next page)

Matching – Tracked Excavators *(continued)*

Match
 Working Range Front Only
 Allowed Usage on Machine Less Than 50%
 No Match

313 GC

Pin-on

Undercarriage	—			L		
Counterweight	2.14 mt	2.25 mt		2.47 mt		
Boom Type	Reach	Reach		Reach		
Stick Length	2.50 m (8'2")	2.50 m (8'2")	3.00 m (9'10")	2.50 m (8'2")	2.80 m (9'2")	3.00 m (9'10")
H110 S	✓	✓	✓	✓	✓	✓
H115 S	✓	✓	✓	✓	✓	✓

Cat Pin Grabber Coupler

Undercarriage	—			L		
Counterweight	2.14 mt	2.25 mt		2.47 mt		
Boom Type	Reach	Reach		Reach		
Stick Length	2.50 m (8'2")	3.00 m (9'10")	2.50 m (8'2")	2.50 m (8'2")	2.80 m (9'2")	3.00 m (9'10")
H110 S	✓	✓	✓	✓	✓	✓
H115 S	✓		✓	✓	✓	✓

CW-20 S Dedicated Coupler

Undercarriage	—			L	
Counterweight	2.25 mt		2.47 mt		
Boom Type	Reach		Reach		
Stick Length	3.00 m (9'10")	2.50 m (8'2")	2.50 m (8'2")	3.00 m (9'10")	
H110 S	✓*	✓	✓	✓	
H115 S		✓	✓	✓	

CW-20 Dedicated Coupler

Undercarriage	—		L
Counterweight	2.25 mt		2.47 mt
Boom Type	Reach	Reach	Reach
Stick Length	2.50 m (8'2")	2.50 m (8'2")	3.00 m (9'10")
H110 S	✓	✓	✓
H115 S	✓*	✓	✓

S60 Dedicated Coupler

Undercarriage	L	
Counterweight	2.47 mt	
Boom Type	Reach	
Stick Length	2.50 m (8'2")	3.00 m (9'10")
H110 S	✓	✓
H115 S	✓	✓

HCS60 Dedicated Coupler

Undercarriage	L	
Counterweight	2.47 mt	
Boom Type	Reach	
Stick Length	2.50 m (8'2")	3.00 m (9'10")
H110 S	✓	✓
H115 S	✓	✓

(continued on next page)

Hammer Technical Specifications

Matching – Tracked Excavators *(continued)*

Match
 Working Range Front Only
 Allowed Usage on Machine Less Than 50%
 No Match

313 GC *(continued)*

HCS65 Dedicated Coupler

Undercarriage	L	
Counterweight	2.47 mt	
Boom Type	Reach	
Stick Length	2.50 m (8'2")	3.00 m (9'10")
H110 S	✓	✓
H115 S	✓	✓

Tilt-Rotator TRS10 with CW20s Dedicated Coupler

Undercarriage	L
Counterweight	2.47 mt
Boom Type	Reach
Stick Length	2.50 m (8'2")
H110 S	✓

Tilt-Rotator TRS10 with S60 Dedicated Coupler

Undercarriage	—		L		
Counterweight	2.14 mt	2.25 mt	2.47 mt		
Boom Type	Reach	Reach	Reach		
Stick Length	2.50 m (8'2")	2.50 m (8'2")	2.50 m (8'2")	2.80 m (9'2")	3.00 m (9'10")
H110 S	✓	✓	✓	✓	✓

S60 – Tilt-Rotator TRS10 – S60

Undercarriage	L
Counterweight	2.47 mt
Boom Type	Reach
Stick Length	2.50 m (8'2")
H110 S	✓

Tilt-Rotator TRS10 with HCS60 Dedicated Coupler

Undercarriage	L
Counterweight	2.47 mt
Boom Type	Reach
Stick Length	2.50 m (8'2")
H110 S	✓

313

Pin-on

Undercarriage	—			
Counterweight	2.14 mt		2.47 mt	
Boom Type	Reach		Reach	
Stick Length	2.50 m (8'2")	3.00 m (9'10")	2.50 m (8'2")	3.00 m (9'10")
H110 S	✓	✓	✓	✓
H115 S	✓	✓	✓	✓

(continued on next page)

Matching – Tracked Excavators (continued)

Match
 Working Range Front Only
 Allowed Usage on Machine Less Than 50%
 No Match

313 (continued)

Pin-on (continued)

Undercarriage	L							
Counterweight	2.47 mt							
Boom Type	Reach					VA		
Stick Length	2.20 m (7'3")	2.50 m (8'2")	2.80 m (9'2")	2.80 m TR (9'2")	3.00 m (9'10")	2.20 m (7'3")	2.50 m (8'2")	3.00 m (9'10")
H110 S	✓	✓	✓	✓	✓	✓	✓	✓
H115 S	✓	✓	✓	✓	✓	✓	✓	✓

Cat Pin Grabber Coupler

Undercarriage	—			
Counterweight	2.14 mt		2.47 mt	
Boom Type	Reach		Reach	
Stick Length	2.50 m (8'2")	3.00 m (9'10")	2.50 m (8'2")	3.00 m (9'10")
H110 S	✓	✓	✓	✓
H115 S	✓	✓	✓	✓

Cat Pin Grabber Coupler (continued)

Undercarriage	L							
Counterweight	2.47 mt							
Boom Type	Reach					VA		
Stick Length	2.20 m (7'3")	2.50 m (8'2")	2.80 m (9'2")	3.00 m (9'10")	2.80 m TR (9'2")	2.20 m (7'3")	2.50 m (8'2")	3.00 m (9'10")
H110 S	✓	✓	✓	✓	✓	✓	✓	✓
H115 S	✓	✓	✓	✓	✓	✓	✓	✓

CW-20 S Dedicated Coupler

Undercarriage	L					
Counterweight	2.47 mt					
Boom Type	Reach			VA		
Stick Length	2.20 m (7'3")	2.50 m (8'2")	3.00 m (9'10")	2.20 m (7'3")	2.50 m (8'2")	3.00 m (9'10")
H110 S	✓	✓	✓	✓	✓	✓
H115 S	✓	✓	✓			

CW-20 Dedicated Coupler

Undercarriage	L					
Counterweight	2.47 mt					
Boom Type	Reach			VA		
Stick Length	2.20 m (7'3")	2.50 m (8'2")	3.00 m (9'10")	2.20 m (7'3")	2.50 m (8'2")	3.00 m (9'10")
H110 S	✓	✓	✓	✓	✓	✓
H115 S	✓	✓	✓			

S60 Dedicated Coupler

Undercarriage	L					
Counterweight	2.47 mt					
Boom Type	Reach			VA		
Stick Length	2.20 m (7'3")	2.50 m (8'2")	3.00 m (9'10")	2.20 m (7'3")	2.50 m (8'2")	3.00 m (9'10")
H110 S	✓	✓	✓	✓	✓	✓
H115 S	✓	✓	✓	✓	✓	✓

(continued on next page)

Hammer Technical Specifications

Matching – Tracked Excavators (continued)

Match
 Working Range Front Only
 Allowed Usage on Machine Less Than 50%
 No Match

313 (continued)

HCS60 Dedicated Coupler

Undercarriage	L					
Counterweight	2.47 mt					
Boom Type	Reach			VA		
Stick Length	2.20 m (7'3")	2.50 m (8'2")	3.00 m (9'10")	2.20 m (7'3")	2.50 m (8'2")	3.00 m (9'10")
H110 S	✓	✓	✓	✓	✓	✓
H115 S	✓	✓	✓	✓	✓	✓

HCS65 Dedicated Coupler

Undercarriage	L					
Counterweight	2.47 mt					
Boom Type	Reach			VA		
Stick Length	2.20 m (7'3")	2.50 m (8'2")	3.00 m (9'10")	2.20 m (7'3")	2.50 m (8'2")	3.00 m (9'10")
H110 S	✓	✓	✓	✓	✓	✓
H115 S	✓	✓	✓	✓	✓	✓

Tilt-Rotator TRS10 with CW20s Dedicated Coupler

Undercarriage	L	
Counterweight	2.47 mt	
Boom Type	Reach	
Stick Length	2.20 m (7'3")	2.50 m (8'2")
H110 S	✓	✓

Tilt-Rotator TRS10 with CW20 Dedicated Coupler

Undercarriage	L	
Counterweight	2.47 mt	
Boom Type	Reach	
Stick Length	2.20 m (7'3")	2.50 m (8'2")
H110 S	✓	✓

Tilt-Rotator TRS10 with S60 Dedicated Coupler

Undercarriage	—			L				
Counterweight	2.14 mt	2.47 mt		2.47 mt				
Boom Type	Reach	Reach		Reach				
Stick Length	2.50 m (8'2")	2.50 m (8'2")	3.00 m (9'10")	2.20 m (7'3")	2.50 m (8'2")	2.80 m (9'2")	3.00 m (9'10")	2.80 m TR (9'2")
H110 S	✓	✓	✓	✓	✓	✓	✓	✓

S60 – Tilt-Rotator TRS10 – S60

Undercarriage	L	
Counterweight	2.47 mt	
Boom Type	Reach	
Stick Length	2.20 m (7'3")	2.50 m (8'2")
H110 S	✓	✓

(continued on next page)

Matching – Tracked Excavators *(continued)*

Match
 * Working Range Front Only
 † Allowed Usage on Machine Less Than 50%
 No Match

313 *(continued)*

Tilt-Rotator TRS10 with HCS60 Dedicated Coupler

Undercarriage	L		
Counterweight	2.47 mt		
Boom Type	Reach		
Stick Length	2.20 m (7'3")	2.50 m (8'2")	3.00 m (9'10")
H110 S	✓	✓	✓

HCS60 – Tilt-Rotator TRS10 – HCSS60

Undercarriage	L
Counterweight	2.47 mt
Boom Type	Reach
Stick Length	2.20 m (7'3")
H110 S	✓

315F CR

Pin-on

Undercarriage	L				
Counterweight	—				
Boom Type	Reach				VA
Stick Length	2.50 m (8'2")	2.80 m (9'2")	3.00 m (9'10")	3.00 m TR (9'10")	2.10 m (6'11")
H110 S	✓	✓	✓	✓	✓
H115 S	✓	✓	✓	✓	✓

Cat Pin Grabber Coupler

Undercarriage	L				
Counterweight	—				
Boom Type	Reach				VA
Stick Length	2.50 m (8'2")	2.80 m (9'2")	3.00 m (9'10")	3.00 m TR (9'10")	2.10 m (6'11")
H110 S	✓	✓	✓	✓	✓
H115 S	✓	✓	✓	✓	✓

CW-20 S Dedicated Coupler

Undercarriage	L		
Counterweight	—		
Boom Type	Reach		VA
Stick Length	2.50 m (8'2")	3.00 m (9'10")	2.10 m (6'11")
H110 S	✓	✓	✓
H115 S	✓	✓	✓

CW-20 Dedicated Coupler

Undercarriage	L		
Counterweight	—		
Boom Type	Reach		VA
Stick Length	2.50 m (8'2")	3.00 m (9'10")	2.10 m (6'11")
H110 S	✓	✓	✓
H115 S	✓	✓	✓

(continued on next page)

Hammer Technical Specifications

Matching – Tracked Excavators (continued)

Match
 Working Range Front Only
 Allowed Usage on Machine Less Than 50%
 No Match

315 GC

Pin-on

Undercarriage	—		L			
Counterweight	2.53 mt		2.83 mt			
Boom Type	Reach		Reach			
Stick Length	2.50 m (8'2")	2.80 m (9'2")	2.50 m (8'2")	2.80 m (9'2")	3.00 m (9'10")	2.80 m TR (9'2")
H110 S	✓	✓	✓	✓	✓	✓
H115 S	✓	✓	✓	✓	✓	✓

Cat Pin Grabber Coupler

Undercarriage	—		L			
Counterweight	2.53 mt		3.83 mt			
Boom Type	Reach		Reach			
Stick Length	2.50 m (8'2")	2.50 m (8'2")	2.80 m (9'2")	2.80 m TR (9'2")	3.00 m (9'10")	
H110 S	✓	✓	✓	✓	✓	
H115 S	✓*	✓	✓	✓	✓	

CW-20 S Dedicated Coupler

Undercarriage	L	
Counterweight	3.83 mt	
Boom Type	Reach	
Stick Length	2.50 m (8'2")	3.00 m (9'10")
H110 S	✓	✓
H115 S	✓	✓

CW-20 Dedicated Coupler

Undercarriage	L	
Counterweight	3.83 mt	
Boom Type	Reach	
Stick Length	2.50 m (8'2")	3.00 m (9'10")
H110 S	✓	✓
H115 S	✓	✓

S60 Dedicated Coupler

Undercarriage	L	
Counterweight	3.83 mt	
Boom Type	Reach	
Stick Length	2.50 m (8'2")	3.00 m (9'10")
H110 S	✓	✓
H115 S	✓	✓

HCS60 Dedicated Coupler

Undercarriage	L	
Counterweight	3.83 mt	
Boom Type	Reach	
Stick Length	2.50 m (8'2")	3.00 m (9'10")
H110 S	✓	✓
H115 S	✓	✓

(continued on next page)

Matching – Tracked Excavators *(continued)*

Match
 Working Range Front Only
 Allowed Usage on Machine Less Than 50%
 No Match

315 GC *(continued)*

HCS65 Dedicated Coupler

Undercarriage	L	
Counterweight	3.83 mt	
Boom Type	Reach	
Stick Length	2.50 m (8'2")	3.00 m (9'10")
H110 S	✓	✓
H115 S	✓	✓

Tilt-Rotator TRS10 with S60 Dedicated Coupler

Undercarriage	L			
Counterweight	3.83 mt			
Boom Type	Reach			
Stick Length	2.50 m (8'2")	2.80 m (9'2")	3.00 m (9'10")	2.80 m TR (9'2")
H110 S	✓	✓	✓	✓

S60 – Tilt-Rotator TRS10 – S60

Undercarriage	L
Counterweight	3.83 mt
Boom Type	Reach
Stick Length	2.50 m (8'2")
H110 S	✓

Tilt-Rotator TRS10 with HCS60 Dedicated Coupler

Undercarriage	L	
Counterweight	3.83 mt	
Boom Type	Reach	
Stick Length	2.50 m (8'2")	3.00 m (9'10")
H110 S	✓	✓

315

Cat Pin Grabber Coupler

Undercarriage	—			
Counterweight	2.53 mt		3.83 mt	
Boom Type	Reach		Reach	
Stick Length	2.50 m (8'2")	3.00 m (9'10")	2.50 m (8'2")	3.00 m (9'10")
H110 S	✓	✓*	✓	✓*
H115 S	✓*		✓*	

Cat Pin Grabber Coupler *(continued)*

Undercarriage	L				
Counterweight	3.83 mt				
Boom Type	Reach				
Stick Length	2.20 m (7'3")	2.50 m (8'2")	2.80 m (9'2")	2.80 m TR (9'2")	3.00 m (9'10")
H110 S	✓	✓	✓	✓	✓
H115 S	✓	✓	✓	✓	✓

(continued on next page)

Hammer Technical Specifications

Matching – Tracked Excavators *(continued)*

Match
 * Working Range Front Only
 † Allowed Usage on Machine Less Than 50%
 No Match

315 *(continued)*

CW-20 S Dedicated Coupler

Undercarriage	L		
Counterweight	3.83 mt		
Boom Type	Reach		
Stick Length	2.20 m (7'3")	2.50 m (8'2")	3.00 m (9'10")
H110 S	✓	✓	✓
H115 S	✓	✓	✓

CW-20 Dedicated Coupler

Undercarriage	L		
Counterweight	3.83 mt		
Boom Type	Reach		
Stick Length	2.20 m (7'3")	2.50 m (8'2")	3.00 m (9'10")
H110 S	✓	✓	✓
H115 S	✓	✓	✓

S60 Dedicated Coupler

Undercarriage	L		
Counterweight	3.83 mt		
Boom Type	Reach		
Stick Length	2.20 m (7'3")	2.50 m (8'2")	3.00 m (9'10")
H110 S	✓	✓	✓
H115 S	✓	✓	✓

HCS60 Dedicated Coupler

Undercarriage	L			
Counterweight	3.83 mt			
Boom Type	Reach			VA
Stick Length	2.20 m (7'3")	2.50 m (8'2")	3.00 m (9'10")	2.20 m (7'3")
H110 S	✓	✓	✓	✓
H115 S	✓	✓	✓	

HCS65 Dedicated Coupler

Undercarriage	L		
Counterweight	3.83 mt		
Boom Type	Reach		
Stick Length	2.20 m (7'3")	2.50 m (8'2")	3.00 m (9'10")
H110 S	✓	✓	✓
H115 S	✓	✓	✓

Tilt-Rotator TRS10 with S60 Dedicated Coupler

Undercarriage	L				
Counterweight	3.83 mt				
Boom Type	Reach				
Stick Length	2.20 m (7'3")	2.50 m (8'2")	2.80 m (9'2")	3.00 m (9'10")	2.80 m TR (9'2")
H110 S	✓	✓	✓	✓	✓

(continued on next page)

Matching – Tracked Excavators *(continued)*

Match
 Working Range Front Only
 Allowed Usage on Machine Less Than 50%
 No Match

315 *(continued)*

S60 – Tilt-Rotator TRS10 – S60

Undercarriage	L	
Counterweight	3.83 mt	
Boom Type	Reach	
Stick Length	2.20 m (7'3")	2.50 m (8'2")
H110 S	✓	✓

Tilt-Rotator TRS10 with HCS60 Dedicated Coupler

Undercarriage	L		
Counterweight	3.83 mt		
Boom Type	Reach		
Stick Length	2.20 m (7'3")	2.50 m (8'2")	3.00 m (9'10")
H110 S	✓	✓	✓

HCS60 – Tilt-Rotator TRS10 – HCSS60

Undercarriage	L
Counterweight	3.83 mt
Boom Type	Reach
Stick Length	2.20 m (7'3")
H110 S	✓

316F

Pin-on

Undercarriage	L					
Counterweight	—					
Boom Type	Reach				VA	
Stick Length	2.25 m (7'5")	2.60 m (8'6")	2.90 m (9'6")	3.10 m (10'2")	2.25 m (7'5")	2.60 m (8'6")
H110 S	✓	✓	✓	✓	✓	✓
H115 S	✓	✓	✓	✓	✓	✓
H120 S	✓	✓	✓	✓	✓	✓

Cat Pin Grabber Coupler

Undercarriage	L					
Counterweight	—					
Boom Type	Reach				VA	
Stick Length	2.25 m (7'5")	2.60 m (8'6")	2.90 m (9'6")	3.10 m (10'2")	2.25 m (7'5")	2.60 m (8'6")
H110 S	✓	✓	✓	✓	✓	✓
H115 S	✓	✓	✓	✓	✓	✓
H120 S	✓	✓	✓*			

CW-30 S Dedicated Coupler

Undercarriage	L				
Counterweight	—				
Boom Type	Reach			VA	
Stick Length	2.25 m (7'5")	2.60 m (8'6")	2.90 m (9'6")	2.25 m (7'5")	2.60 m (8'6")
H110 S	✓	✓	✓	✓	✓
H115 S	✓	✓	✓	✓	✓
H120 S	✓	✓	✓		

(continued on next page)

Hammer Technical Specifications

Matching – Tracked Excavators *(continued)*

Match
 * Working Range Front Only
 † Allowed Usage on Machine Less Than 50%
 No Match

316F *(continued)*

CW-30 Dedicated Coupler

Undercarriage	L				
Counterweight	—				
Boom Type	Reach			VA	
Stick Length	2.25 m (7'5")	2.60 m (8'6")	2.90 m (9'6")	2.25 m (7'5")	2.60 m (8'6")
H110 S	✓	✓	✓	✓	✓
H115 S	✓	✓	✓	✓	✓
H120 S	✓	✓	✓		

316 GC

Pin-on

Undercarriage	L	
Counterweight	3.2 mt	
Boom Type	Reach HD	
Stick Length	2.50 m HD (8'2")	3.00 m (9'10")
H110 S	✓	✓
H115 S	✓	✓

Cat Pin Grabber Coupler

Undercarriage	L	
Counterweight	3.2 mt	
Boom Type	Reach HD	
Stick Length	2.50 m HD (8'2")	3.00 m (9'10")
H110 S	✓	✓
H115 S	✓	✓

CW-20 S Dedicated Coupler

Undercarriage	L	
Counterweight	3.2 mt	
Boom Type	Reach HD	
Stick Length	3.00 m (9'10")	2.50 m HD (8'2")
H110 S	✓	✓
H115 S	✓	✓

CW-20 Dedicated Coupler

Undercarriage	L	
Counterweight	3.2 mt	
Boom Type	Reach HD	
Stick Length	3.00 m (9'10")	2.50 m HD (8'2")
H110 S	✓	✓
H115 S	✓	✓

Tilt-Rotator TRS10 with S60 Dedicated Coupler

Undercarriage	L	
Counterweight	3.2 mt	
Boom Type	Reach HD	
Stick Length	3.00 m (9'10")	2.50 m HD (8'2")
H110 S	✓	✓

(continued on next page)

Matching – Tracked Excavators *(continued)*

Match
 * Working Range Front Only
 † Allowed Usage on Machine Less Than 50%
 No Match

317 GC

Pin-on

Undercarriage	L					
Counterweight	3.05 mt			3.57 mt		
Boom Type	Reach			Reach		
Stick Length	2.60 m (8'6")	2.90 m (9'6")	2.60 m (8'6")	2.90 m (9'6")	2.90 m SD (9'6")	3.10 m (10'2")
H110 S	✓	✓	✓	✓	✓	✓
H115 S	✓	✓	✓	✓	✓	✓
H120 S	✓	✓	✓	✓	✓	✓

Cat Pin Grabber Coupler

Undercarriage	L					
Counterweight	3.05 mt			3.57 mt		
Boom Type	Reach			Reach		
Stick Length	2.60 m (8'6")	2.90 m (9'6")	2.60 m (8'6")	2.90 m (9'6")	2.90 m SD (9'6")	3.10 m (10'2")
H110 S	✓	✓	✓	✓	✓	✓
H115 S	✓	✓	✓	✓	✓	✓
H120 S	✓	✓*	✓	✓	✓	✓

CW-30 S Dedicated Coupler

Undercarriage	L	
Counterweight	3.05 mt	
Boom Type	Reach	
Stick Length	2.60 m (8'6")	2.90 m (9'6")
H110 S	✓	✓
H115 S	✓	✓
H120 S	✓	✓

CW-30 Dedicated Coupler

Undercarriage	L	
Counterweight	3.05 mt	
Boom Type	Reach	
Stick Length	2.60 m (8'6")	2.90 m (9'6")
H110 S	✓	✓
H115 S	✓	✓
H120 S	✓	✓*

S60 Dedicated Coupler

Undercarriage	L	
Counterweight	3.05 mt	
Boom Type	Reach	
Stick Length	2.60 m (8'6")	2.90 m (9'6")
H110 S	✓	✓
H115 S	✓	✓

(continued on next page)

Hammer Technical Specifications

Matching – Tracked Excavators *(continued)*

Match
 Working Range Front Only
 Allowed Usage on Machine Less Than 50%
 No Match

317 GC *(continued)*

HCS60 Dedicated Coupler

Undercarriage	L	
Counterweight	3.05 mt	
Boom Type	Reach	
Stick Length	2.60 m (8'6")	2.90 m (9'6")
H110 S	✓	✓
H115 S	✓	✓
H120 S	✓	✓

HCS65 Dedicated Coupler

Undercarriage	L	
Counterweight	3.05 mt	
Boom Type	Reach	
Stick Length	2.60 m (8'6")	2.90 m (9'6")
H110 S	✓	✓
H115 S	✓	✓
H120 S	✓	✓

Tilt-Rotator TRS14 with CW30 S Dedicated Coupler

Undercarriage	L	
Counterweight	3.05 mt	
Boom Type	Reach	
Stick Length	2.60 m (8'6")	2.90 m (9'6")
H110 S	✓	✓
H115 S	✓	✓

CW30 S – Tilt-Rotator TRS10 – CW30 S

Undercarriage	L
Counterweight	3.05 mt
Boom Type	Reach
Stick Length	2.60 m (8'6")
H110 S	✓

Tilt-Rotator TRS14 with CW30 Dedicated Coupler

Undercarriage	L	
Counterweight	3.05 mt	
Boom Type	Reach	
Stick Length	2.60 m (8'6")	2.90 m (9'6")
H110 S	✓	✓
H115 S	✓	

Tilt-Rotator TRS14 with S60 Dedicated Coupler

Undercarriage	L						
Counterweight	3.05 mt			3.57 mt			
Boom Type	Reach			Reach			
Stick Length	2.60 m (8'6")	2.90 m (9'6")	3.10 m (10'2")	2.60 m (8'6")	2.90 m (9'6")	3.10 m (10'2")	2.90 m SD (9'6")
H110 S	✓	✓	✓	✓	✓	✓	✓
H115 S	✓	✓	✓	✓	✓	✓	✓

(continued on next page)

Matching – Tracked Excavators *(continued)*

Match
 Working Range Front Only
 Allowed Usage on Machine Less Than 50%
 No Match

317 GC *(continued)*

S60 – Tilt-Rotator TRS14 – S60

Undercarriage	L	
Counterweight	3.05 mt	
Boom Type	Reach	
Stick Length	2.60 m (8'6")	2.90 m (9'6")
H110 S	✓	✓
H115 S	✓	✓

Tilt-Rotator TRS14 with HCS60 Dedicated Coupler

Undercarriage	L	
Counterweight	3.05 mt	
Boom Type	Reach	
Stick Length	2.60 m (8'6")	2.90 m (9'6")
H110 S	✓	✓
H115 S	✓	✓

HCS60 – Tilt-Rotator TRS14 – HCS60

Undercarriage	L	
Counterweight	3.05 mt	
Boom Type	Reach	
Stick Length	2.60 m (8'6")	2.90 m (9'6")
H110 S	✓	✓
H115 S	✓	

Tilt-Rotator TRS14 with HCS65 Dedicated Coupler

Undercarriage	L	
Counterweight	3.05 mt	
Boom Type	Reach	
Stick Length	2.60 m (8'6")	2.90 m (9'6")
H110 S	✓	✓
H115 S	✓	✓

317

Pin-on

Undercarriage	L			
Counterweight	3.05 mt			
Boom Type	Reach			
Stick Length	2.60 m (8'6")	2.90 m (9'6")	2.90 m SD (9'6")	3.10 m (10'2")
H110 S	✓	✓	✓	✓
H115 S	✓	✓	✓	✓
H120 S	✓	✓	✓	✓

Pin-on *(continued)*

Undercarriage	L					
Counterweight	3.57 mt					
Boom Type	Reach				VA	
Stick Length	2.60 m (8'6")	2.90 m (9'6")	2.90 m SD (9'6")	3.10 m (10'2")	2.25 m (7'5")	2.60 m (8'6")
H110 S	✓	✓	✓	✓	✓	✓
H115 S	✓	✓	✓	✓	✓	✓
H120 S	✓	✓	✓	✓	✓	✓

(continued on next page)

Hammer Technical Specifications

Matching – Tracked Excavators (continued)

Match
 Working Range Front Only
 Allowed Usage on Machine Less Than 50%
 No Match

317 (continued)

Cat Pin Grabber Coupler

Undercarriage	L			
Counterweight	3.05 mt			
Boom Type	Reach			
Stick Length	2.60 m (8'6")	2.90 m (9'6")	2.90 m SD (9'6")	3.10 m (10'2")
H110 S	✓	✓	✓	✓
H115 S	✓	✓	✓	✓
H120 S	✓	✓	✓*	✓*

Cat Pin Grabber Coupler (continued)

Undercarriage	L					
Counterweight	3.57 mt					
Boom Type	Reach				VA	
Stick Length	2.60 m (8'6")	2.90 m (9'6")	2.90 m SD (9'6")	3.10 m (10'2")	2.25 m (7'5")	2.60 m (8'6")
H110 S	✓	✓	✓	✓	✓	✓
H115 S	✓	✓	✓	✓	✓	✓
H120 S	✓	✓	✓	✓	✓	✓

CW-30 S Dedicated Coupler

Undercarriage	L			
Counterweight	3.57 mt			
Boom Type	Reach		VA	
Stick Length	2.25 m (7'5")	3.10 m (10'2")	2.20 m (7'3")	2.60 m (8'6")
H110 S	✓	✓	✓	✓
H115 S	✓	✓	✓	✓
H120 S	✓	✓		

CW-30 Dedicated Coupler

Undercarriage	L			
Counterweight	3.57 mt			
Boom Type	Reach		VA	
Stick Length	2.60 m (8'6")	3.10 m (10'2")	2.25 m (7'5")	2.60 m (8'6")
H110 S	✓	✓	✓	✓
H115 S	✓	✓	✓	✓
H120 S	✓	✓		

S60 Dedicated Coupler

Undercarriage	L			
Counterweight	3.57 mt			
Boom Type	Reach		VA	
Stick Length	2.60 m (8'6")	3.10 m (10'2")	2.25 m (7'5")	2.60 m (8'6")
H110 S	✓	✓	✓	✓
H115 S	✓	✓	✓	✓

(continued on next page)

Matching – Tracked Excavators *(continued)*

Match
 Working Range Front Only
 Allowed Usage on Machine Less Than 50%
 No Match

317 *(continued)*

HCS60 Dedicated Coupler

Undercarriage	L			
Counterweight	3.57 mt			
Boom Type	Reach		VA	
Stick Length	2.60 m (8'6")	3.10 m (10'2")	2.25 m (7'5")	2.60 m (8'6")
H110 S	✓	✓	✓	✓
H115 S	✓	✓	✓	✓
H120 S	✓	✓	✓	✓

HCS65 Dedicated Coupler

Undercarriage	L			
Counterweight	3.57 mt			
Boom Type	Reach		VA	
Stick Length	2.60 m (8'6")	3.10 m (10'2")	2.25 m (7'5")	2.60 m (8'6")
H110 S	✓	✓	✓	✓
H115 S	✓	✓	✓	✓
H120 S	✓	✓	✓	✓

Tilt-Rotator TRS14 with CW30 S Dedicated Coupler

Undercarriage	L	
Counterweight	3.57 mt	
Boom Type	Reach	
Stick Length	2.60 m (8'6")	3.10 m (10'2")
H110 S	✓	✓
H115 S	✓	✓

CW30 S – Tilt-Rotator TRS10 – CW30 S

Undercarriage	L	
Counterweight	3.57 mt	
Boom Type	Reach	
Stick Length	2.60 m (8'6")	3.10 m (10'2")
H110 S	✓	✓
H115 S	✓	

Tilt-Rotator TRS14 with CW30 Dedicated Coupler

Undercarriage	L	
Counterweight	3.57 mt	
Boom Type	Reach	
Stick Length	2.60 m (8'6")	3.10 m (10'2")
H110 S	✓	✓
H115 S	✓	✓

CW30 – Tilt-Rotator TRS14 – CW30

Undercarriage	L
Counterweight	3.57 mt
Boom Type	Reach
Stick Length	2.60 m (8'6")
H110 S	✓
H115 S	✓

(continued on next page)

Hammer Technical Specifications

Matching – Tracked Excavators (continued)

Match
 Working Range Front Only
 Allowed Usage on Machine Less Than 50%
 No Match

317 (continued)

Tilt-Rotator TRS14 with S60 Dedicated Coupler

Undercarriage	L			
Counterweight	3.05 mt			
Boom Type	Reach			
Stick Length	2.60 m (8'6")	2.90 m (9'6")	3.10 m (10'2")	2.90 m SD (9'6")
H110 S	✓	✓	✓	✓
H115 S	✓	✓	✓	✓

Tilt-Rotator TRS14 with S60 Dedicated Coupler (continued)

Undercarriage	L					
Counterweight	3.57 mt					
Boom Type	Reach					
Stick Length	2.60 m (8'6")	2.90 m (9'6")	3.10 m (10'2")	2.90 m SD (9'6")	2.25 m (7'5")	2.60 m (8'6")
H110 S	✓	✓	✓	✓	✓	✓
H115 S	✓	✓	✓	✓	✓	✓

S60 – Tilt-Rotator TRS14 – S60

Undercarriage	L			
Counterweight	3.57 mt			
Boom Type	Reach		VA	
Stick Length	2.60 m (8'6")	3.10 m (10'2")	2.25 m (7'5")	2.60 m (8'6")
H110 S	✓	✓	✓	✓
H115 S	✓	✓		

Tilt-Rotator TRS14 with HCS60 Dedicated Coupler

Undercarriage	L			
Counterweight	3.57 mt			
Boom Type	Reach		VA	
Stick Length	2.60 m (8'6")	3.10 m (10'2")	2.25 m (7'5")	2.60 m (8'6")
H110 S	✓	✓	✓	✓
H115 S	✓	✓	✓	✓

HCS60 – Tilt-Rotator TRS14 – HCS60

Undercarriage	L			
Counterweight	3.57 mt			
Boom Type	Reach		VA	
Stick Length	2.60 m (8'6")	3.10 m (10'2")	2.25 m (7'5")	2.60 m (8'6")
H110 S	✓	✓	✓	✓
H115 S	✓	✓		

Tilt-Rotator TRS14 with HCS65 Dedicated Coupler

Undercarriage	L			
Counterweight	3.57 mt			
Boom Type	Reach		VA	
Stick Length	2.60 m (8'6")	3.10 m (10'2")	2.25 m (7'5")	2.60 m (8'6")
H110 S	✓	✓	✓	✓
H115 S	✓	✓	✓	✓

(continued on next page)

Matching – Tracked Excavators *(continued)*

Match
 * Working Range Front Only
 † Allowed Usage on Machine Less Than 50%
 No Match

317 *(continued)*

HCS65 – Tilt-Rotator TRS14 – HCS65

Undercarriage	L			
Counterweight	3.57 mt			
Boom Type	Reach		VA	
Stick Length	2.60 m (8'6")	3.10 m (10'2")	2.25 m (7'5")	2.60 m (8'6")
H110 S	✓	✓	✓	✓
H115 S	✓			

318D2

Pin-on

Undercarriage	L			
Counterweight	—			
Boom Type	Reach		Reach HD	
Stick Length	2.60 m (8'6")	2.90 m (9'6")	2.60 m HD (8'6")	2.90 m (9'6")
H115 GC	✓	✓	✓	✓
H115 S	✓	✓	✓	✓
H120 S	✓	✓	✓	✓

Cat Pin Grabber Coupler

Undercarriage	L			
Counterweight	—			
Boom Type	Reach		Reach HD	
Stick Length	2.60 m (8'6")	2.90 m (9'6")	2.60 m HD (8'6")	2.90 m (9'6")
H115 GC	✓	✓	✓	✓
H115 S	✓	✓	✓	✓
H120 S	✓	✓*	✓*	✓*

CW-30 S Dedicated Coupler

Undercarriage	L
Counterweight	—
Boom Type	Reach
Stick Length	2.60 m (8'6")
H115 GC	✓
H115 S	✓
H120 S	✓

CW-30 Dedicated Coupler

Undercarriage	L
Counterweight	—
Boom Type	Reach
Stick Length	2.60 m (8'6")
H115 GC	✓
H115 S	✓
H120 S	✓

(continued on next page)

Hammer Technical Specifications

Matching – Tracked Excavators *(continued)*

Match
 Working Range Front Only
 Allowed Usage on Machine Less Than 50%
 No Match

318F

Pin-on

Undercarriage	L					
Counterweight	—					
Boom Type	Reach				VA	
Stick Length	2.25 m (7'5")	2.60 m (8'6")	2.90 m (9'6")	3.10 m (10'2")	2.25 m (7'5")	2.60 m (8'6")
H115 GC			✓	✓		
H115 S	✓	✓	✓	✓	✓	✓
H120 S	✓	✓	✓	✓	✓	✓
H130 S	✓	✓	✓	✓		

Cat Pin Grabber Coupler

Undercarriage	L					
Counterweight	—					
Boom Type	Reach				VA	
Stick Length	2.25 m (7'5")	2.60 m (8'6")	2.90 m (9'6")	3.10 m (10'2")	2.25 m (7'5")	2.60 m (8'6")
H115 GC			✓	✓		
H115 S	✓	✓	✓	✓	✓	✓
H120 S	✓	✓	✓	✓*	✓	✓
H130 S	✓	✓*	✓*			

CW-30 S Dedicated Coupler

Undercarriage	L					
Counterweight	—					
Boom Type	Reach				VA	
Stick Length	2.25 m (7'5")	2.60 m (8'6")	2.90 m (9'6")	3.10 m (10'2")	2.25 m (7'5")	2.60 m (8'6")
H115 S	✓	✓	✓	✓	✓	✓
H120 S	✓	✓	✓	✓		
H130 S	✓	✓*	✓*			

CW-30 Dedicated Coupler

Undercarriage	L					
Counterweight	—					
Boom Type	Reach				VA	
Stick Length	2.25 m (7'5")	2.60 m (8'6")	2.90 m (9'6")	3.10 m (10'2")	2.25 m (7'5")	2.60 m (8'6")
H115 S	✓	✓	✓	✓	✓	✓
H120 S	✓	✓	✓	✓	✓	✓
H130 S	✓	✓*	✓*			

320D2 GC

Pin-on

Undercarriage	—	
Counterweight	—	
Boom Type	Reach	
Stick Length	2.50 m (8'2")	2.92 m (9'7")
H115 S	✓	✓
H120 S	✓	✓
H130 S	✓	✓

(continued on next page)

Matching – Tracked Excavators *(continued)*

Match
 * Working Range Front Only
 † Allowed Usage on Machine Less Than 50%
 No Match

320D2 GC *(continued)*

Cat Pin Grabber Coupler

Undercarriage	—	
Counterweight	—	
Boom Type	Reach	
Stick Length	2.50 m (8'2")	2.92 m (9'7")
H115 S	✓	✓
H120 S	✓	✓
H130 S	✓	✓*

CW-40 S Dedicated Coupler

Undercarriage	—	
Counterweight	—	
Boom Type	Reach	
Stick Length	2.50 m (8'2")	2.92 m (9'7")
H115 S	✓	✓
H120 S	✓	✓
H130 S	✓	✓

CW-40 Dedicated Coupler

Undercarriage	—	
Counterweight	—	
Boom Type	Reach	
Stick Length	2.50 m (8'2")	2.92 m (9'7")
H115 S	✓	✓
H120 S	✓	✓
H130 S	✓	✓*

320D2

Pin-on

Undercarriage	—			L		
Counterweight	—			—		
Boom Type	Reach HD		ME	Reach HD		ME
Stick Length	2.50 m HD (8'2")	2.92 m HD (9'7")	2.40 m (7'10")	2.50 m HD (8'2")	2.92 m HD (9'7")	2.40 m (7'10")
H115 S	✓	✓		✓	✓	
H120 S	✓	✓	✓	✓	✓	✓
H130 S	✓	✓	✓	✓	✓	✓

Cat Pin Grabber Coupler

Undercarriage	—		L	
Counterweight	—		—	
Boom Type	Reach HD		Reach HD	
Stick Length	2.50 m HD (8'2")	2.92 m HD (9'7")	2.50 m HD (8'2")	2.92 m HD (9'7")
H115 S	✓	✓	✓	✓
H120 S	✓	✓	✓	✓
H130 S	✓*		✓	✓

(continued on next page)

Hammer Technical Specifications

Matching – Tracked Excavators *(continued)*

Match
 * Working Range Front Only
 † Allowed Usage on Machine Less Than 50%
 No Match

320D2 *(continued)*

CW-40 S Dedicated Coupler

Undercarriage	L	
Counterweight	—	
Boom Type	Reach HD	
Stick Length	2.50 m HD (8'2")	2.92 m HD (9'7")
H115 S	✓	✓
H120 S	✓	✓
H130 S	✓	✓

CW-40 Dedicated Coupler

Undercarriage	L	
Counterweight	—	
Boom Type	Reach HD	
Stick Length	2.50 m HD (8'2")	2.92 m HD (9'7")
H115 S	✓	✓
H120 S	✓	✓
H130 S	✓	✓

320F

Pin-on

Undercarriage	—		L			
Counterweight	—		—			
Boom Type	Reach	VA	Reach		VA	
Stick Length	2.92 m HD (9'7")	2.92 m HD (9'7")	2.50 m HD (8'2")	2.92 m HD (9'7")	2.50 m HD (8'2")	2.92 m HD (9'7")
H115 S	✓	✓	✓	✓	✓	✓
H120 S	✓	✓	✓	✓	✓	✓
H130 S	✓	✓	✓	✓	✓	✓

Cat Pin Grabber Coupler

Undercarriage	—		L			
Counterweight	—		—			
Boom Type	Reach	Reach		VA		
Stick Length	2.92 m HD (9'7")	2.50 m HD (8'2")	2.92 m HD (9'7")	2.50 m HD (8'2")	2.92 m HD (9'7")	
H115 S	✓	✓	✓	✓	✓	
H120 S	✓	✓	✓	✓	✓	
H130 S	✓*	✓	✓	✓	✓	

CW-40 S Dedicated Coupler

Undercarriage	—		L			
Counterweight	—		—			
Boom Type	Reach	VA	Reach		VA	
Stick Length	2.92 m HD (9'7")	2.92 m HD (9'7")	2.50 m HD (8'2")	2.92 m HD (9'7")	2.50 m HD (8'2")	2.92 m HD (9'7")
H115 S	✓	✓	✓	✓	✓	✓
H120 S	✓	✓	✓	✓	✓	✓
H130 S	✓	✓*	✓	✓	✓	✓

(continued on next page)

Matching – Tracked Excavators (continued)

Match
 * Working Range Front Only
 † Allowed Usage on Machine Less Than 50%
 No Match

320F (continued)

CW-40 Dedicated Coupler

Undercarriage	—				L	
Counterweight	—				—	
Boom Type	Reach		VA		Reach	
Stick Length	2.92 m HD (9'7")	2.92 m HD (9'7")	2.50 m HD (8'2")	2.92 m HD (9'7")	2.50 m HD (8'2")	2.92 m HD (9'7")
H115 S	✓	✓	✓	✓	✓	✓
H120 S	✓	✓	✓	✓	✓	✓
H130 S	✓	✓*	✓	✓	✓	✓

320 GC

Pin-on

Undercarriage	—				L	
Counterweight	3.7 mt		4.2 mt		4.2 mt	
Boom Type	Reach		Reach		Reach	
Stick Length	2.50 m (8'2")	2.92 m (9'7")	2.50 m (8'2")	2.92 m (9'7")	2.50 m (8'2")	2.92 m (9'7")
H115 S	✓	✓	✓	✓	✓	✓
H120 S	✓	✓	✓	✓	✓	✓
H130 S	✓	✓†	✓	✓†	✓	✓†

Cat Pin Grabber Coupler

Undercarriage	—				L	
Counterweight	3.7 mt		4.2 mt		4.2 mt	
Boom Type	Reach		Reach		Reach	
Stick Length	2.50 m (8'2")	2.92 m (9'7")	2.50 m (8'2")	2.92 m (9'7")	2.50 m (8'2")	2.92 m (9'7")
H115 S	✓	✓	✓	✓	✓	✓
H120 S	✓†	✓†	✓†	✓†	✓†	✓†
H130 S	✓†	✓†*	✓†	✓†	✓†	✓†

CW-40 S Dedicated Coupler

Undercarriage	—				L	
Counterweight	3.7 mt		4.2 mt		4.2 mt	
Boom Type	Reach		Reach		Reach	
Stick Length	2.50 m (8'2")	2.92 m (9'7")	2.50 m (8'2")	2.92 m (9'7")	2.50 m (8'2")	2.92 m (9'7")
H115 S	✓	✓	✓	✓	✓	✓
H120 S	✓†	✓†	✓†	✓†	✓†	✓†
H130 S	✓†	✓†	✓†	✓†	✓†	✓†

CW-40 Dedicated Coupler

Undercarriage	—				L	
Counterweight	3.7 mt		4.2 mt		4.2 mt	
Boom Type	Reach		Reach		Reach	
Stick Length	2.50 m (8'2")	2.92 m (9'7")	2.50 m (8'2")	2.92 m (9'7")	2.50 m (8'2")	2.92 m (9'7")
H115 S	✓	✓	✓	✓	✓	✓
H120 S	✓†	✓†	✓†	✓†	✓†	✓†
H130 S	✓†	✓†	✓†	✓†	✓†	✓†

(continued on next page)

Hammer Technical Specifications

Matching – Tracked Excavators *(continued)*

Match
 * Working Range Front Only
 † Allowed Usage on Machine Less Than 50%
 No Match

320 GX

CW-40 S Dedicated Coupler

Undercarriage	—	
Counterweight	3.6 mt	
Boom Type	Reach	
Stick Length	2.50 m (8'2")	2.70 m (8'10")
H115 S	✓	✓
H120 S	✓	✓
H130 S	✓	✓

CW-40 Dedicated Coupler

Undercarriage	—	
Counterweight	3.6 mt	
Boom Type	Reach	
Stick Length	2.50 m (8'2")	2.70 m (8'10")
H115 S	✓	✓
H120 S	✓	✓
H130 S	✓	✓

320

Pin-on

Undercarriage	—			
Counterweight	3.7 mt			
Boom Type	Reach		Reach HD	
Stick Length	2.50 m (8'2")	2.92 m (9'7")	2.50 m HD (8'2")	2.92 m HD (9'7")
H115 S	✓	✓	✓	✓
H120 S	✓	✓	✓	✓
H130 S	✓	✓†	✓	✓

Pin-on *(continued)*

Undercarriage	L							
Counterweight	3.7 mt				4.2 mt			
Boom Type	Reach HD		Reach		Reach HD		VA	
Stick Length	2.50 m HD (8'2")	2.92 m HD (9'7")	2.50 m (8'2")	2.92 m (9'7")	2.50 m HD (8'2")	2.92 m HD (9'7")	2.50 m (8'2")	2.92 m (9'7")
H115 S	✓	✓	✓	✓	✓	✓	✓	✓
H120 S	✓	✓	✓	✓	✓	✓	✓	✓
H130 S	✓	✓	✓	✓†	✓	✓	✓	✓†

Cat Pin Grabber Coupler

Undercarriage	—			
Counterweight	3.7 mt			
Boom Type	Reach		Reach HD	
Stick Length	2.50 m (8'2")	2.92 m (9'7")	2.50 m HD (8'2")	2.92 m HD (9'7")
H115 S	✓	✓	✓	✓
H120 S	✓†	✓†	✓	✓
H130 S	✓†	✓†*	✓*	

(continued on next page)

Matching – Tracked Excavators (continued)

Match
 * Working Range Front Only
 † Allowed Usage on Machine Less Than 50%
 No Match

320 (continued)

Cat Pin Grabber Coupler (continued)

Undercarriage	L							
Counterweight	3.7 mt				4.2 mt			
Boom Type	Reach HD		Reach		Reach HD		VA	
Stick Length	2.50 m HD (8'2")	2.92 m HD (9'7")	2.50 m (8'2")	2.92 m (9'7")	2.50 m HD (8'2")	2.92 m HD (9'7")	2.50 m (8'2")	2.92 m (9'7")
H115 S	✓	✓	✓	✓	✓	✓	✓	✓
H120 S	✓	✓	✓†	✓†	✓	✓	✓†	✓†
H130 S	✓	✓	✓†	✓†	✓	✓	✓†	✓†

CW-40 S Dedicated Coupler

Undercarriage	L							
Counterweight	3.7 mt				4.2 mt			
Boom Type	Reach HD		Reach		Reach HD		VA	
Stick Length	2.50 m HD (8'2")	2.92 m HD (9'7")	2.50 m (8'2")	2.92 m (9'7")	2.50 m HD (8'2")	2.92 m HD (9'7")	2.50 m (8'2")	2.92 m (9'7")
H115 S	✓	✓	✓	✓	✓	✓	✓	✓
H120 S	✓	✓	✓†	✓†	✓	✓	✓†	✓†
H130 S	✓	✓	✓†	✓†	✓	✓	✓†	✓†

CW-40 Dedicated Coupler

Undercarriage	L							
Counterweight	3.7 mt				4.2 mt			
Boom Type	Reach HD		Reach		Reach HD		VA	
Stick Length	2.50 m HD (8'2")	2.92 m HD (9'7")	2.50 m (8'2")	2.92 m (9'7")	2.50 m HD (8'2")	2.92 m HD (9'7")	2.50 m (8'2")	2.92 m (9'7")
H115 S	✓	✓	✓	✓	✓	✓	✓	✓
H120 S	✓	✓	✓†	✓†	✓	✓	✓†	✓†
H130 S	✓	✓	✓†	✓†	✓	✓	✓†	✓†

323D2

Pin-on

Undercarriage	L			
Counterweight	—			
Boom Type	Reach	Reach HD		ME
Stick Length	2.92 m (9'7")	2.50 m HD (8'2")	2.92 m HD (9'7")	2.40 m (7'10")
H120 S	✓	✓	✓	✓
H130 S	✓	✓	✓	✓

Cat Pin Grabber Coupler

Undercarriage	L		
Counterweight	—		
Boom Type	Reach HD		ME
Stick Length	2.50 m HD (8'2")	2.92 m HD (9'7")	2.40 m (7'10")
H120 S	✓	✓	✓
H130 S	✓	✓	✓

(continued on next page)

Hammer Technical Specifications

Matching – Tracked Excavators *(continued)*

Match
 Working Range Front Only
 Allowed Usage on Machine Less Than 50%
 No Match

323D2 *(continued)*

CW-40 S Dedicated Coupler

Undercarriage	L	
Counterweight	—	
Boom Type	Reach HD	
Stick Length	2.50 m HD (8'2")	2.92 m HD (9'7")
H120 S	✓	✓
H130 S	✓	✓

CW-40 Dedicated Coupler

Undercarriage	L		
Counterweight	—		
Boom Type	Reach HD		ME
Stick Length	2.50 m HD (8'2")	2.92 m HD (9'7")	2.40 m (7'10")
H120 S	✓	✓	✓
H130 S	✓	✓	✓

323F

Pin-on

Undercarriage	L						
Counterweight	—						
Boom Type	Reach		Reach HD			VA	
Stick Length	2.50 m HD (8'2")	2.92 m HD (9'7")	2.92 m HD (9'7")	2.92 m HD-TR (9'7")	3.86 m HD (12'8")	2.50 m HD (8'2")	2.92 m HD (9'7")
H120 S	✓	✓	✓	✓	✓	✓	✓
H130 S	✓	✓	✓	✓	✓	✓	✓

Pin-on *(continued)*

Undercarriage	L							
Counterweight	5.35 mt				—			
Boom Type	Reach		VA		Reach		VA	
Stick Length	2.50 m HD (8'2")	2.92 m HD (9'7")	2.50 m HD (8'2")	2.92 m HD (9'7")	2.50 m HD (8'2")	2.92 m HD (9'7")	2.50 m HD (8'2")	2.92 m HD (9'7")
H120 S	✓	✓	✓	✓	✓	✓	✓	✓
H130 S	✓	✓	✓	✓	✓	✓	✓	✓

Cat Pin Grabber Coupler

Undercarriage	L						
Counterweight	—						
Boom Type	Reach		Reach HD			VA	
Stick Length	2.50 m HD (8'2")	2.92 m HD (9'7")	2.92 m HD (9'7")	2.92 m HD-TR (9'7")	3.86 m HD (12'8")	2.50 m HD (8'2")	2.92 m HD (9'7")
H120 S	✓	✓	✓	✓	✓	✓	✓
H130 S	✓	✓	✓	✓	✓	✓	✓

(continued on next page)

Matching – Tracked Excavators (continued)

Match
 Working Range Front Only
 Allowed Usage on Machine Less Than 50%
 No Match

323F (continued)

Cat Pin Grabber Coupler (continued)

Undercarriage	L				LN			
Counterweight	5.35 mt				—			
Boom Type	Reach		VA		Reach		VA	
Stick Length	2.50 m HD (8'2")	2.92 m HD (9'7")	2.50 m HD (8'2")	2.92 m HD (9'7")	2.50 m HD (8'2")	2.92 m HD (9'7")	2.50 m HD (8'2")	2.92 m HD (9'7")
H120 S	✓	✓	✓	✓	✓	✓	✓	✓
H130 S	✓	✓	✓	✓	✓	✓	✓*	

CW-40 S Dedicated Coupler

Undercarriage	L							
Counterweight	—				5.35 mt			
Boom Type	Reach		VA		Reach		VA	
Stick Length	2.50 m HD (8'2")	2.92 m HD (9'7")	2.50 m HD (8'2")	2.92 m HD (9'7")	2.50 m HD (8'2")	2.92 m HD (9'7")	2.50 m HD (8'2")	2.92 m HD (9'7")
H120 S	✓	✓	✓	✓	✓	✓	✓	✓
H130 S	✓	✓	✓	✓	✓	✓	✓	✓

CW-40 S Dedicated Coupler (continued)

Undercarriage	LN			
Counterweight	—			
Boom Type	Reach		VA	
Stick Length	2.50 m HD (8'2")	2.92 m HD (9'7")	2.50 m HD (8'2")	2.92 m HD (9'7")
H120 S	✓	✓	✓	✓
H130 S	✓	✓	✓	✓*

CW-40 Dedicated Coupler

Undercarriage	L							
Counterweight	—				5.35 mt			
Boom Type	Reach		VA		Reach		VA	
Stick Length	2.50 m HD (8'2")	2.92 m HD (9'7")	2.50 m HD (8'2")	2.92 m HD (9'7")	2.50 m HD (8'2")	2.92 m HD (9'7")	2.50 m HD (8'2")	2.92 m HD (9'7")
H120 S	✓	✓	✓	✓	✓	✓	✓	✓
H130 S	✓	✓	✓	✓	✓	✓	✓	✓

CW-40 Dedicated Coupler (continued)

Undercarriage	LN			
Counterweight	—			
Boom Type	Reach		VA	
Stick Length	2.50 m HD (8'2")	2.92 m HD (9'7")	2.50 m HD (8'2")	2.92 m HD (9'7")
H120 S	✓	✓	✓	✓
H130 S	✓	✓	✓	✓*

323 GC

Pin-on

Undercarriage	L	
Counterweight	4.7 mt	
Boom Type	Reach	
Stick Length	2.50 m (8'2")	2.92 m (9'7")
H120 S	✓	✓
H130 S	✓	✓†

(continued on next page)

Hammer Technical Specifications

Matching – Tracked Excavators *(continued)*

Match
 Working Range Front Only
 Allowed Usage on Machine Less Than 50%
 No Match

323 GC *(continued)*

Cat Pin Grabber Coupler

Undercarriage	L	
Counterweight	4.7 mt	
Boom Type	Reach	
Stick Length	2.50 m (8'2")	2.92 m (9'7")
H120 S	✓†	✓†
H130 S	✓†	✓†

CW-40 S Dedicated Coupler

Undercarriage	L	
Counterweight	4.7 mt	
Boom Type	Reach	
Stick Length	2.50 m (8'2")	2.92 m (9'7")
H120 S	✓	✓
H130 S	✓	✓

CW-40 Dedicated Coupler

Undercarriage	L	
Counterweight	4.7 mt	
Boom Type	Reach	
Stick Length	2.50 m (8'2")	2.92 m (9'7")
H120 S	✓	✓
H130 S	✓	✓

323 GX

Pin-on

Undercarriage	—	L	MID
Counterweight	4.55 mt	4.25 mt	4.25 mt
Boom Type	Reach	Reach	Reach
Stick Length	2.92 m (9'7")	2.92 m (9'7")	2.92 m (9'7")
H120 S	✓	✓	✓
H130 S	✓†	✓†	✓†

CW-40 S Dedicated Coupler

Undercarriage	MID
Counterweight	4.25 mt
Boom Type	Reach
Stick Length	2.92 m (9'7")
H120 S	✓
H130 S	✓

CW-40 Dedicated Coupler

Undercarriage	MID
Counterweight	4.25 mt
Boom Type	Reach
Stick Length	2.92 m (9'7")
H120 S	✓
H130 S	✓

(continued on next page)

Hammer Technical Specifications

Matching – Tracked Excavators (continued)

Match
 Working Range Front Only
 † Allowed Usage on Machine Less Than 50%
 No Match

323

Pin-on

Undercarriage	L						
Counterweight	4.2 mt						
Boom Type	Reach			Reach HD			
Stick Length	2.50 m (8'2")	2.92 m (9'7")	3.86 m (12'8")	2.50 m (8'2")	2.50 m HD (8'2")	2.92 m (9'7")	2.92 m HD (9'7")
H120 S	✓	✓	✓	✓	✓	✓	✓
H130 S	✓	✓†	✓	✓	✓	✓	✓

Pin-on (continued)

Undercarriage	L				
Counterweight	4.2 mt		5.4 mt		
Boom Type	VA		Reach		
Stick Length	2.50 m (8'2")	2.92 m (9'7")	2.50 m (8'2")	2.92 m (9'7")	3.86 m (12'8")
H120 S	✓	✓	✓	✓	✓
H130 S	✓	✓†	✓	✓†	✓

Pin-on (continued)

Undercarriage	L						
Counterweight	5.4 mt						
Boom Type	Reach HD					VA	
Stick Length	2.50 m (8'2")	2.50 m HD (8'2")	2.92 m (9'7")	2.92 m HD (9'7")	2.92 m TR (9'7")	2.50 m (8'2")	2.92 m (9'7")
H120 S	✓	✓	✓	✓	✓	✓	✓
H130 S	✓	✓	✓	✓	✓	✓	✓†

Pin-on (continued)

Undercarriage	LN				SA			
Counterweight	4.5 mt				4.5 mt			
Boom Type	Reach		VA		Reach		VA	
Stick Length	2.50 m (8'2")	2.92 m (9'7")	2.50 m (8'2")	2.92 m (9'7")	2.50 m (8'2")	2.92 m (9'7")	2.50 m (8'2")	2.92 m (9'7")
H120 S	✓	✓	✓	✓	✓	✓	✓	✓
H130 S	✓	✓†	✓	✓†	✓	✓†	✓	✓†

Cat Pin Grabber Coupler

Undercarriage	L						
Counterweight	4.2 mt						
Boom Type	Reach			Reach HD			
Stick Length	2.50 m (8'2")	2.92 m (9'7")	3.86 m (12'8")	2.50 m (8'2")	2.50 m HD (8'2")	2.92 m (9'7")	2.92 m HD (9'7")
H120 S	✓†	✓†	✓†	✓	✓	✓	✓
H130 S	✓†	✓†		✓	✓	✓	✓

Cat Pin Grabber Coupler (continued)

Undercarriage	L				
Counterweight	4.2 mt		5.4 mt		
Boom Type	VA		Reach		
Stick Length	2.50 m (8'2")	2.92 m (9'7")	2.50 m (8'2")	2.92 m (9'7")	3.86 m (12'8")
H120 S	✓†	✓†	✓†	✓†	✓†
H130 S	✓†	✓†	✓†	✓†	

(continued on next page)

Hammer Technical Specifications

Matching – Tracked Excavators (continued)

Match
 Working Range Front Only
 Allowed Usage on Machine Less Than 50%
 No Match

323 (continued)

Cat Pin Grabber Coupler (continued)

Undercarriage	L						
Counterweight	5.4 mt						
Boom Type	Reach HD					VA	
Stick Length	2.50 m (8'2")	2.50 m HD (8'2")	2.92 m (9'7")	2.92 m HD (9'7")	2.92 m TR (9'7")	2.50 m (8'2")	2.92 m (9'7")
H120 S	✓	✓	✓	✓	✓	✓†	✓†
H130 S	✓	✓	✓	✓	✓	✓†	✓†

CW-40 S Dedicated Coupler

Undercarriage	L					
Counterweight	4.2 mt					
Boom Type	Reach		Reach HD		VA	
Stick Length	2.50 m (8'2")	2.92 m (9'7")	2.50 m HD (8'2")	2.92 m HD (9'7")	2.50 m (8'2")	2.92 m (9'7")
H120 S	✓†	✓†	✓	✓	✓†	✓†
H130 S	✓†	✓†	✓	✓	✓†	✓†

CW-40 S Dedicated Coupler (continued)

Undercarriage	L					
Counterweight	5.4 mt					
Boom Type	Reach		Reach HD		VA	
Stick Length	2.50 m (8'2")	2.92 m (9'7")	2.50 m HD (8'2")	2.92 m HD (9'7")	2.50 m (8'2")	2.92 m (9'7")
H120 S	✓†	✓†	✓	✓	✓†	✓†
H130 S	✓†	✓†	✓	✓	✓†	✓†

CW-40 Dedicated Coupler

Undercarriage	L					
Counterweight	4.2 mt					
Boom Type	Reach		Reach HD		VA	
Stick Length	2.50 m (8'2")	2.92 m (9'7")	2.50 m HD (8'2")	2.92 m HD (9'7")	2.50 m (8'2")	2.92 m (9'7")
H120 S	✓†	✓†	✓	✓	✓†	✓†
H130 S	✓†	✓†	✓	✓	✓†	✓†

CW-40 Dedicated Coupler (continued)

Undercarriage	L					
Counterweight	5.4 mt					
Boom Type	Reach		Reach HD		VA	
Stick Length	2.50 m (8'2")	2.92 m (9'7")	2.50 m HD (8'2")	2.92 m HD (9'7")	2.50 m (8'2")	2.92 m (9'7")
H120 S	✓†	✓†	✓	✓	✓†	✓†
H130 S	✓†	✓†	✓	✓	✓†	✓†

S70 Dedicated Coupler

Undercarriage	L					
Counterweight	4.2 mt					
Boom Type	Reach		Reach HD		VA	
Stick Length	2.50 m (8'2")	2.92 m (9'7")	2.50 m HD (8'2")	2.92 m HD (9'7")	2.50 m (8'2")	2.92 m (9'7")
H120 S	✓	✓	✓	✓	✓	✓
H130 S	✓	✓	✓	✓	✓	✓

(continued on next page)

Matching – Tracked Excavators (continued)

Match
 * Working Range Front Only
 † Allowed Usage on Machine Less Than 50%
 No Match

323 (continued)

S70 Dedicated Coupler (continued)

Undercarriage	L					
Counterweight	5.4 mt					
Boom Type	Reach		Reach HD		VA	
Stick Length	2.50 m (8'2")	2.92 m (9'7")	2.50 m HD (8'2")	2.92 m HD (9'7")	2.50 m (8'2")	2.92 m (9'7")
H120 S	✓	✓	✓	✓	✓	✓
H130 S	✓	✓	✓	✓	✓	✓

S70 Dedicated Coupler (continued)

Undercarriage	LN				SA			
Counterweight	4.5 mt				4.5 mt			
Boom Type	Reach		VA		Reach		VA	
Stick Length	2.50 m (8'2")	2.92 m (9'7")	2.50 m (8'2")	2.92 m (9'7")	2.50 m (8'2")	2.92 m (9'7")	2.50 m (8'2")	2.92 m (9'7")
H120 S	✓	✓	✓	✓	✓	✓	✓	✓
H130 S	✓	✓	✓	✓	✓	✓	✓	✓

HCS70 Dedicated Coupler

Undercarriage	L					
Counterweight	4.2 mt					
Boom Type	Reach		Reach HD		VA	
Stick Length	2.50 m (8'2")	2.92 m (9'7")	2.50 m HD (8'2")	2.92 m HD (9'7")	2.50 m (8'2")	2.92 m (9'7")
H120 S	✓	✓	✓	✓	✓	✓
H130 S	✓	✓	✓	✓	✓	✓

HCS70 Dedicated Coupler (continued)

Undercarriage	L					
Counterweight	5.4 mt					
Boom Type	Reach		Reach HD		VA	
Stick Length	2.50 m (8'2")	2.92 m (9'7")	2.50 m HD (8'2")	2.92 m HD (9'7")	2.50 m (8'2")	2.92 m (9'7")
H120 S	✓	✓	✓	✓	✓	✓
H130 S	✓	✓	✓	✓	✓	✓

HCS70 Dedicated Coupler (continued)

Undercarriage	LN				SA			
Counterweight	4.5 mt				4.5 mt			
Boom Type	Reach		VA		Reach		VA	
Stick Length	2.50 m (8'2")	2.92 m (9'7")	2.50 m (8'2")	2.92 m (9'7")	2.50 m (8'2")	2.92 m (9'7")	2.50 m (8'2")	2.92 m (9'7")
H120 S	✓	✓	✓	✓	✓	✓	✓	✓
H130 S	✓	✓	✓	✓	✓	✓	✓	✓

HCS70-55 Dedicated Coupler

Undercarriage	L					
Counterweight	4.2 mt					
Boom Type	Reach		Reach HD		VA	
Stick Length	2.50 m (8'2")	2.92 m (9'7")	2.50 m HD (8'2")	2.92 m HD (9'7")	2.50 m (8'2")	2.92 m (9'7")
H120 S	✓	✓	✓	✓	✓	✓
H130 S	✓	✓	✓	✓	✓	✓

(continued on next page)

Hammer Technical Specifications

Matching – Tracked Excavators (continued)

Match
 Working Range Front Only
 Allowed Usage on Machine Less Than 50%
 No Match

323 (continued)

HCS70-55 Dedicated Coupler (continued)

Undercarriage	L					
Counterweight	5.4 mt					
Boom Type	Reach		Reach HD		VA	
Stick Length	2.50 m (8'2")	2.92 m (9'7")	2.50 m HD (8'2")	2.92 m HD (9'7")	2.50 m (8'2")	2.92 m (9'7")
H120 S	✓	✓	✓	✓	✓	✓
H130 S	✓	✓	✓	✓	✓	✓

HCS70-55 Dedicated Coupler (continued)

Undercarriage	LN				SA			
Counterweight	4.5 mt				4.5 mt			
Boom Type	Reach		VA		Reach		VA	
Stick Length	2.50 m (8'2")	2.92 m (9'7")	2.50 m (8'2")	2.92 m (9'7")	2.50 m (8'2")	2.92 m (9'7")	2.50 m (8'2")	2.92 m (9'7")
H120 S	✓	✓	✓	✓	✓	✓	✓	✓
H130 S	✓	✓	✓	✓	✓	✓	✓	✓

Tilt-Rotator TRS18 with CW30 S Dedicated Coupler

Undercarriage	L					
Counterweight	4.2 mt					
Boom Type	Reach		Reach HD		VA	
Stick Length	2.50 m (8'2")	2.92 m (9'7")	2.50 m HD (8'2")	2.92 m HD (9'7")	2.50 m (8'2")	2.92 m (9'7")
H115 S	✓	✓	✓	✓	✓	✓
H120 S	✓	✓	✓	✓	✓	✓

Tilt-Rotator TRS18 with CW30 S Dedicated Coupler (continued)

Undercarriage	L					
Counterweight	5.4 mt					
Boom Type	Reach		Reach HD		VA	
Stick Length	2.50 m (8'2")	2.92 m (9'7")	2.50 m HD (8'2")	2.92 m HD (9'7")	2.50 m (8'2")	2.92 m (9'7")
H115 S	✓	✓	✓	✓	✓	✓
H120 S	✓	✓	✓	✓	✓	✓

Tilt-Rotator TRS18 with CW30 S Dedicated Coupler (continued)

Undercarriage	LN				SA			
Counterweight	4.5 mt				4.5 mt			
Boom Type	Reach	Reach	VA	VA	Reach	Reach	VA	VA
Stick Length	2.50 m (8'2")	2.92 m (9'7")	2.50 m (8'2")	2.92 m (9'7")	2.50 m (8'2")	2.92 m (9'7")	2.50 m (8'2")	2.92 m (9'7")
H115 S	✓	✓	✓	✓	✓	✓	✓	✓
H120 S	✓	✓	✓	✓	✓	✓	✓	✓

CW30 S – Tilt-Rotator TRS18 – CW30 S

Undercarriage	L					
Counterweight	4.2 mt					
Boom Type	Reach	Reach	Reach HD	Reach HD	VA	VA
Stick Length	2.50 m (8'2")	2.92 m (9'7")	2.50 m HD (8'2")	2.92 m HD (9'7")	2.50 m (8'2")	2.92 m (9'7")
H115 S	✓	✓	✓	✓	✓	✓
H120 S	✓	✓	✓	✓	✓	✓

(continued on next page)

Matching – Tracked Excavators (continued)

Match
 Working Range Front Only
 Allowed Usage on Machine Less Than 50%
 No Match

323 (continued)

CW30 S – Tilt-Rotator TRS18 – CW30 S (continued)

Undercarriage	L					
Counterweight	5.4 mt					
Boom Type	Reach	Reach	Reach HD	Reach HD	VA	VA
Stick Length	2.50 m (8'2")	2.92 m (9'7")	2.50 m HD (8'2")	2.92 m HD (9'7")	2.50 m (8'2")	2.92 m (9'7")
H115 S	✓	✓	✓	✓	✓	✓
H120 S	✓	✓	✓	✓	✓	✓

CW30 S – Tilt-Rotator TRS18 – CW30 S (continued)

Undercarriage	LN				SA			
Counterweight	4.5 mt				4.5 mt			
Boom Type	Reach	Reach	VA	VA	Reach	Reach	VA	VA
Stick Length	2.50 m (8'2")	2.92 m (9'7")	2.50 m (8'2")	2.92 m (9'7")	2.50 m (8'2")	2.92 m (9'7")	2.50 m (8'2")	2.92 m (9'7")
H115 S	✓	✓	✓	✓	✓	✓	✓	✓
H120 S	✓	✓	✓	✓	✓	✓	✓	✓

Tilt-Rotator TRS18 with CW30 Dedicated Coupler

Undercarriage	L					
Counterweight	4.2 mt					
Boom Type	Reach		Reach HD		VA	
Stick Length	2.50 m (8'2")	2.92 m (9'7")	2.50 m HD (8'2")	2.92 m HD (9'7")	2.50 m (8'2")	2.92 m (9'7")
H115 S	✓	✓	✓	✓	✓	✓
H120 S	✓	✓	✓	✓	✓	✓

Tilt-Rotator TRS18 with CW30 Dedicated Coupler (continued)

Undercarriage	L					
Counterweight	5.4 mt					
Boom Type	Reach		Reach HD		VA	
Stick Length	2.50 m (8'2")	2.92 m (9'7")	2.50 m HD (8'2")	2.92 m HD (9'7")	2.50 m (8'2")	2.92 m (9'7")
H115 S	✓	✓	✓	✓	✓	✓
H120 S	✓	✓	✓	✓	✓	✓

Tilt-Rotator TRS18 with CW30 Dedicated Coupler (continued)

Undercarriage	LN				SA			
Counterweight	4.5 mt				4.5 mt		4.5 mt	
Boom Type	Reach		VA		Reach		VA	
Stick Length	2.50 m (8'2")	2.92 m (9'7")	2.50 m (8'2")	2.92 m (9'7")	2.50 m (8'2")	2.92 m (9'7")	2.50 m (8'2")	2.92 m (9'7")
H115 S	✓	✓	✓	✓	✓	✓	✓	✓
H120 S	✓	✓	✓	✓	✓	✓	✓	✓

CW30 – Tilt-Rotator TRS18 – CW30

Undercarriage	L					
Counterweight	4.2 mt					
Boom Type	Reach		Reach HD		VA	
Stick Length	2.50 m (8'2")	2.92 m (9'7")	2.50 m HD (8'2")	2.92 m HD (9'7")	2.50 m (8'2")	2.92 m (9'7")
H115 S	✓	✓	✓	✓	✓	✓
H120 S	✓	✓	✓	✓	✓	✓

(continued on next page)

Hammer Technical Specifications

Matching – Tracked Excavators (continued)

Match
 Working Range Front Only
 Allowed Usage on Machine Less Than 50%
 No Match

323 (continued)

CW30 – Tilt-Rotator TRS18 – CW30 (continued)

Undercarriage	L					
Counterweight	5.4 mt					
Boom Type	Reach		Reach HD		VA	
Stick Length	2.50 m (8'2")	2.92 m (9'7")	2.50 m HD (8'2")	2.92 m HD (9'7")	2.50 m (8'2")	2.92 m (9'7")
H115 S	✓	✓	✓	✓	✓	✓
H120 S	✓	✓	✓	✓	✓	✓

CW30 – Tilt-Rotator TRS18 – CW30 (continued)

Undercarriage	LN				SA			
Counterweight	4.5 mt				4.5 mt			
Boom Type	Reach		VA		Reach		VA	
Stick Length	2.50 m (8'2")	2.92 m (9'7")	2.50 m (8'2")	2.92 m (9'7")	2.50 m (8'2")	2.92 m (9'7")	2.50 m (8'2")	2.92 m (9'7")
H115 S	✓	✓	✓	✓	✓	✓	✓	✓
H120 S	✓				✓			

Tilt-Rotator TRS18 with S70 Dedicated Coupler

Undercarriage	L							
Counterweight	4.2 mt							
Boom Type	Reach			Reach HD			VA	
Stick Length	2.50 m (8'2")	2.92 m (9'7")	3.86 m (12'8")	2.50 m (8'2")	2.50 m HD (8'2")	2.92 m (9'7")	2.50 m (8'2")	2.92 m (9'7")
H115 S	✓	✓	✓	✓	✓	✓	✓	✓
H120 S	✓	✓		✓	✓	✓	✓	✓

Tilt-Rotator TRS18 with S70 Dedicated Coupler (continued)

Undercarriage	L					
Counterweight	5.4 mt					
Boom Type	Reach			Reach HD		
Stick Length	2.50 m (8'2")	2.92 m (9'7")	3.86 m (12'8")	2.50 m (8'2")	2.50 m HD (8'2")	2.92 m (9'7")
H115 S	✓	✓	✓	✓	✓	✓
H120 S	✓	✓		✓	✓	✓

Tilt-Rotator TRS18 with S70 Dedicated Coupler (continued)

Undercarriage	L			LN			
Counterweight	5.4 mt			4.5 mt			
Boom Type	Reach HD		VA	Reach		VA	
Stick Length	2.92 m HD (9'7")	2.50 m (8'2")	2.92 m (9'7")	2.50 m (8'2")	2.92 m (9'7")	2.50 m (8'2")	2.92 m (9'7")
H115 S	✓	✓	✓	✓	✓	✓	✓
H120 S	✓	✓	✓	✓	✓	✓	

Tilt-Rotator TRS18 with S70 Dedicated Coupler (continued)

Undercarriage	SA			
Counterweight	4.5 mt			
Boom Type	Reach		VA	
Stick Length	2.50 m (8'2")	2.92 m (9'7")	2.50 m (8'2")	2.92 m (9'7")
H115 S	✓	✓	✓	✓
H120 S	✓	✓	✓	✓

(continued on next page)

Matching – Tracked Excavators (continued)

Match
 Working Range Front Only
 Allowed Usage on Machine Less Than 50%
 No Match

323 (continued)

S70 – Tilt-Rotator TRS18 – S70

Undercarriage	L					
Counterweight	4.2 mt					
Boom Type	Reach		Reach HD		VA	
Stick Length	2.50 m (8'2")	2.92 m (9'7")	2.50 m HD (8'2")	2.92 m HD (9'7")	2.50 m (8'2")	2.92 m (9'7")
H115 S	✓	✓	✓	✓	✓	✓
H120 S	✓	✓	✓	✓	✓	

S70 – Tilt-Rotator TRS18 – S70 (continued)

Undercarriage	L					
Counterweight	5.4 mt					
Boom Type	Reach		Reach HD		VA	
Stick Length	2.50 m (8'2")	2.92 m (9'7")	2.50 m HD (8'2")	2.92 m HD (9'7")	2.50 m (8'2")	2.92 m (9'7")
H115 S	✓	✓	✓	✓	✓	✓
H120 S	✓	✓	✓	✓	✓	✓

S70 – Tilt-Rotator TRS18 – S70 (continued)

Undercarriage	LN				SA			
Counterweight	4.5 mt				4.5 mt			
Boom Type	Reach		VA		Reach		VA	
Stick Length	2.50 m (8'2")	2.92 m (9'7")	2.50 m (8'2")	2.92 m (9'7")	2.50 m (8'2")	2.92 m (9'7")	2.50 m (8'2")	2.92 m (9'7")
H115 S	✓	✓	✓	✓	✓	✓	✓	✓
H120 S	✓	✓			✓	✓		

Tilt-Rotator TRS18 with HCS70 Dedicated Coupler

Undercarriage	L					
Counterweight	4.2 mt					
Boom Type	Reach		Reach HD		VA	
Stick Length	2.50 m (8'2")	2.92 m (9'7")	2.50 m HD (8'2")	2.92 m HD (9'7")	2.50 m (8'2")	2.92 m (9'7")
H115 S	✓	✓	✓	✓	✓	✓
H120 S	✓	✓	✓	✓	✓	✓

Tilt-Rotator TRS18 with HCS70 Dedicated Coupler (continued)

Undercarriage	L					
Counterweight	5.4 mt					
Boom Type	Reach		Reach HD		VA	
Stick Length	2.50 m (8'2")	2.92 m (9'7")	2.50 m HD (8'2")	2.92 m HD (9'7")	2.50 m (8'2")	2.92 m (9'7")
H115 S	✓	✓	✓	✓	✓	✓
H120 S	✓	✓	✓	✓	✓	✓

Tilt-Rotator TRS18 with HCS70 Dedicated Coupler (continued)

Undercarriage	LN				SA			
Counterweight	4.5 mt				4.5 mt			
Boom Type	Reach		VA		Reach		VA	
Stick Length	2.50 m (8'2")	2.92 m (9'7")	2.50 m (8'2")	2.92 m (9'7")	2.50 m (8'2")	2.92 m (9'7")	2.50 m (8'2")	2.92 m (9'7")
H115 S	✓	✓	✓	✓	✓	✓	✓	✓
H120 S	✓	✓	✓		✓	✓	✓	

(continued on next page)

Hammer Technical Specifications

Matching – Tracked Excavators (continued)

Match
 * Working Range Front Only
 † Allowed Usage on Machine Less Than 50%
 No Match

323 (continued)

HCS70 – Tilt-Rotator TRS18 – HCS70

Undercarriage	L					
Counterweight	4.2 mt					
Boom Type	Reach		Reach HD		VA	
Stick Length	2.50 m (8'2")	2.92 m (9'7")	2.50 m HD (8'2")	2.92 m HD (9'7")	2.50 m (8'2")	2.92 m (9'7")
H115 S	✓	✓	✓	✓	✓	✓
H120 S	✓	✓	✓	✓		

HCS70 – Tilt-Rotator TRS18 – HCS70 (continued)

Undercarriage	L					
Counterweight	5.4 mt					
Boom Type	Reach		Reach HD		VA	
Stick Length	2.50 m (8'2")	2.92 m (9'7")	2.50 m HD (8'2")	2.92 m HD (9'7")	2.50 m (8'2")	2.92 m (9'7")
H115 S	✓	✓	✓	✓	✓	✓
H120 S	✓	✓	✓	✓	✓	✓

HCS70 – Tilt-Rotator TRS18 – HCS70 (continued)

Undercarriage	LN			SA		
Counterweight	4.5 mt			4.5 mt		
Boom Type	Reach		VA	Reach		VA
Stick Length	2.50 m (8'2")	2.92 m (9'7")	2.50 m (8'2")	2.50 m (8'2")	2.92 m (9'7")	2.50 m (8'2")
H115 S	✓	✓	✓	✓	✓	✓
H120 S				✓		

Tilt-Rotator TRS18 with HCS70-55 Dedicated Coupler

Undercarriage	L					
Counterweight	4.2 mt					
Boom Type	Reach		Reach HD		VA	
Stick Length	2.50 m (8'2")	2.92 m (9'7")	2.50 m HD (8'2")	2.92 m HD (9'7")	2.50 m (8'2")	2.92 m (9'7")
H115 S	✓	✓	✓	✓	✓	✓
H120 S	✓	✓	✓	✓	✓	✓

Tilt-Rotator TRS18 with HCS70-55 Dedicated Coupler (continued)

Undercarriage	L					
Counterweight	5.4 mt					
Boom Type	Reach		Reach HD		VA	
Stick Length	2.50 m (8'2")	2.92 m (9'7")	2.50 m HD (8'2")	2.92 m HD (9'7")	2.50 m (8'2")	2.92 m (9'7")
H115 S	✓	✓	✓	✓	✓	✓
H120 S	✓	✓	✓	✓	✓	✓

HCS70-55 – TRS18 – HCS70-55

Undercarriage	L					
Counterweight	4.2 mt					
Boom Type	Reach		Reach HD		VA	
Stick Length	2.50 m (8'2")	2.92 m (9'7")	2.50 m HD (8'2")	2.92 m HD (9'7")	2.50 m (8'2")	2.92 m (9'7")
H115 S	✓	✓	✓	✓	✓	✓
H120 S	✓	✓	✓			

(continued on next page)

Matching – Tracked Excavators *(continued)*

Match
 * Working Range Front Only
 † Allowed Usage on Machine Less Than 50%
 No Match

323 *(continued)*

HCS70-55 – TRS18 – HCS70-55 *(continued)*

Undercarriage	L					
Counterweight	5.4 mt					
Boom Type	Reach		Reach HD		VA	
Stick Length	2.50 m (8'2")	2.92 m (9'7")	2.50 m HD (8'2")	2.92 m HD (9'7")	2.50 m (8'2")	2.92 m (9'7")
H115 S	✓	✓	✓	✓	✓	✓
H120 S	✓	✓	✓		✓	✓

HCS70-55 – TRS18 – HCS70-55 *(continued)*

Undercarriage	LN		SA		
Counterweight	4.5 mt		4.5 mt		
Boom Type	Reach		Reach		VA
Stick Length	2.50 m (8'2")	2.92 m (9'7")	2.50 m (8'2")	2.92 m (9'7")	2.50 m (8'2")
H115 S	✓	✓	✓	✓	✓
H120 S					

325F CR

Pin-on

Undercarriage	L	
Counterweight	—	
Boom Type	Reach	VA
Stick Length	2.92 m HD (9'7")	2.92 m HD (9'7")
H120 S	✓	✓
H130 S	✓	✓

Cat Pin Grabber Coupler

Undercarriage	L	
Counterweight	—	
Boom Type	Reach	VA
Stick Length	2.92 m HD (9'7")	2.92 m HD (9'7")
H120 S	✓	✓
H130 S	✓	✓

CW-40 S Dedicated Coupler

Undercarriage	L	
Counterweight	—	
Boom Type	Reach	VA
Stick Length	2.92 m HD (9'7")	2.92 m HD (9'7")
H120 S	✓	✓
H130 S	✓	✓

CW-40 Dedicated Coupler

Undercarriage	L	
Counterweight	—	
Boom Type	Reach	VA
Stick Length	2.92 m HD (9'7")	2.92 m HD (9'7")
H120 S	✓	✓
H130 S	✓	✓

(continued on next page)

Hammer Technical Specifications

Matching – Tracked Excavators (continued)

Match
 Working Range Front Only
 Allowed Usage on Machine Less Than 50%
 No Match

325

Pin-on

Undercarriage	—		L	
Counterweight	4.9 mt		4.9 mt	
Boom Type	Reach	Reach HD	Reach	Reach HD
Stick Length	2.92 m (9'7")	2.92 m HD (9'7")	2.92 m (9'7")	2.92 m HD (9'7")
H120 S	✓	✓	✓	✓
H130 S	✓†	✓*	✓†	✓

Pin-on (continued)

Undercarriage	L					
Counterweight	6.7 mt					
Boom Type	Reach			Reach HD		VA
Stick Length	2.92 m (9'7")	2.92 m HD (9'7")	2.92 m TR (9'7")	2.92 m (9'7")	2.92 m HD (9'7")	2.92 m (9'7")
H120 S	✓	✓	✓	✓	✓	✓
H130 S	✓†	✓	✓	✓†	✓	✓†

Pin-on (continued)

Undercarriage	L					
Counterweight	8.3 mt					
Boom Type	Reach			Reach HD		VA
Stick Length	2.92 m (9'7")	2.92 m HD (9'7")	2.92 m TR (9'7")	2.92 m (9'7")	2.92 m HD (9'7")	2.92 m (9'7")
H120 S	✓	✓	✓	✓	✓	✓
H130 S	✓†	✓	✓	✓†	✓	✓†

Pin-on (continued)

Undercarriage	L with Blade (up)					
Counterweight	4.9 mt					
Boom Type	Reach			Reach HD		VA
Stick Length	2.92 m (9'7")	2.92 m HD (9'7")	2.92 m TR (9'7")	2.92 m (9'7")	2.92 m HD (9'7")	2.92 m (9'7")
H120 S	✓	✓	✓	✓	✓	✓
H130 S	✓†	✓	✓	✓†	✓	✓†

Cat Pin Grabber Coupler

Undercarriage	—		L	
Counterweight	4.9 mt		4.9 mt	
Boom Type	Reach	Reach HD	Reach	Reach HD
Stick Length	2.92 m (9'7")	2.92 m HD (9'7")	2.92 m (9'7")	2.92 m HD (9'7")
H120 S	✓†*	✓*	✓†	✓
H130 S			✓†	✓†*

Cat Pin Grabber Coupler (continued)

Undercarriage	L					
Counterweight	6.7 mt					
Boom Type	Reach			Reach HD		VA
Stick Length	2.92 m (9'7")	2.92 m HD (9'7")	2.92 m TR (9'7")	2.92 m (9'7")	2.92 m HD (9'7")	2.92 m (9'7")
H120 S	✓†	✓	✓	✓†	✓	✓†
H130 S	✓†	✓	✓	✓†	✓	✓†

(continued on next page)

Matching – Tracked Excavators *(continued)*

Match
 * Working Range Front Only
 † Allowed Usage on Machine Less Than 50%
 No Match

325 *(continued)*

Cat Pin Grabber Coupler *(continued)*

Undercarriage	L					
Counterweight	8.3 mt					
Boom Type	Reach			Reach HD		VA
Stick Length	2.92 m (9'7")	2.92 m HD (9'7")	2.92 m TR (9'7")	2.92 m (9'7")	2.92 m HD (9'7")	2.92 m (9'7")
H120 S	✓†	✓	✓	✓†	✓	✓†
H130 S	✓†	✓	✓	✓†	✓	✓†

Cat Pin Grabber Coupler *(continued)*

Undercarriage	L with Blade (up)					
Counterweight	4.9 mt					
Boom Type	Reach			Reach HD		VA
Stick Length	2.92 m (9'7")	2.92 m HD (9'7")	2.92 m TR (9'7")	2.92 m (9'7")	2.92 m HD (9'7")	2.92 m (9'7")
H120 S	✓†	✓	✓	✓†	✓	✓†
H130 S	✓†	✓	✓	✓†	✓	

CW-40 S Dedicated Coupler

Undercarriage	L with Blade (up)					
Counterweight	4.9 mt					
Boom Type	Reach	Reach	Reach HD	Reach HD	VA	
Stick Length	2.92 m (9'7")	2.92 m HD (9'7")	2.92 m (9'7")	2.92 m HD (9'7")	2.92 m (9'7")	
H120 S	✓	✓	✓	✓	✓	
H130 S	✓	✓	✓	✓	✓	

CW-40 S Dedicated Coupler *(continued)*

Undercarriage	L					
Counterweight	6.7 mt					
Boom Type	Reach		Reach HD		VA	
Stick Length	2.92 m (9'7")	2.92 m HD (9'7")	2.92 m (9'7")	2.92 m HD (9'7")	2.92 m (9'7")	
H120 S	✓	✓	✓	✓	✓	
H130 S	✓	✓	✓	✓	✓	

CW-40 S Dedicated Coupler *(continued)*

Undercarriage	L					
Counterweight	8.3 mt					
Boom Type	Reach		Reach HD		VA	
Stick Length	2.92 m (9'7")	2.92 m HD (9'7")	2.92 m (9'7")	2.92 m HD (9'7")	2.92 m (9'7")	
H120 S	✓	✓	✓	✓	✓	
H130 S	✓	✓	✓	✓	✓	

CW-40 Dedicated Coupler

Undercarriage	L					
Counterweight	6.7 mt					
Boom Type	Reach		Reach HD		VA	
Stick Length	2.92 m (9'7")	2.92 m HD (9'7")	2.92 m (9'7")	2.92 m HD (9'7")	2.92 m (9'7")	
H120 S	✓	✓	✓	✓	✓	
H130 S	✓	✓	✓	✓	✓	

(continued on next page)

Hammer Technical Specifications

Matching – Tracked Excavators *(continued)*

Match
 * Working Range Front Only
 † Allowed Usage on Machine Less Than 50%
 No Match

325 *(continued)*

CW-40 Dedicated Coupler *(continued)*

Undercarriage	L				
Counterweight	8.3 mt				
Boom Type	Reach		Reach HD		VA
Stick Length	2.92 m (9'7")	2.92 m HD (9'7")	2.92 m (9'7")	2.92 m HD (9'7")	2.92 m (9'7")
H120 S	✓	✓	✓	✓	✓
H130 S	✓	✓	✓	✓	✓

CW-40 Dedicated Coupler *(continued)*

Undercarriage	L with Blade (up)				
Counterweight	4.9 mt				
Boom Type	Reach		Reach HD		VA
Stick Length	2.92 m (9'7")	2.92 m HD (9'7")	2.92 m (9'7")	2.92 m HD (9'7")	2.92 m (9'7")
H120 S	✓	✓	✓	✓	✓
H130 S	✓	✓	✓	✓	✓

S70 Dedicated Coupler

Undercarriage	L				
Counterweight	6.7 mt				
Boom Type	Reach		Reach HD		VA
Stick Length	2.92 m (9'7")	2.92 m HD (9'7")	2.92 m (9'7")	2.92 m HD (9'7")	2.92 m (9'7")
H120 S	✓	✓	✓	✓	✓
H130 S	✓	✓	✓	✓	✓

S70 Dedicated Coupler *(continued)*

Undercarriage	L				
Counterweight	8.3 mt				
Boom Type	Reach		Reach HD		VA
Stick Length	2.92 m (9'7")	2.92 m HD (9'7")	2.92 m (9'7")	2.92 m HD (9'7")	2.92 m (9'7")
H120 S	✓	✓	✓	✓	✓
H130 S	✓	✓	✓	✓	✓

S70 Dedicated Coupler *(continued)*

Undercarriage	L with Blade (up)				
Counterweight	4.9 mt				
Boom Type	Reach		Reach HD		VA
Stick Length	2.92 m (9'7")	2.92 m HD (9'7")	2.92 m (9'7")	2.92 m HD (9'7")	2.92 m (9'7")
H120 S	✓	✓	✓	✓	✓
H130 S	✓	✓	✓	✓	✓

HCS70 Dedicated Coupler

Undercarriage	L				
Counterweight	6.7 mt				
Boom Type	Reach		Reach HD		VA
Stick Length	2.92 m (9'7")	2.92 m HD (9'7")	2.92 m (9'7")	2.92 m HD (9'7")	2.92 m (9'7")
H120 S	✓	✓	✓	✓	✓
H130 S	✓	✓	✓	✓	✓

(continued on next page)

Matching – Tracked Excavators *(continued)*

Match
 * Working Range Front Only
 † Allowed Usage on Machine Less Than 50%
 No Match

325 *(continued)*

HCS70 Dedicated Coupler *(continued)*

Undercarriage	L				
Counterweight	8.3 mt				
Boom Type	Reach		Reach HD		VA
Stick Length	2.92 m (9'7")	2.92 m HD (9'7")	2.92 m (9'7")	2.92 m HD (9'7")	2.92 m (9'7")
H120 S	✓	✓	✓	✓	✓
H130 S	✓	✓	✓	✓	✓

HCS70 Dedicated Coupler *(continued)*

Undercarriage	L with Blade (up)				
Counterweight	4.9 mt				
Boom Type	Reach		Reach HD		VA
Stick Length	2.92 m (9'7")	2.92 m HD (9'7")	2.92 m (9'7")	2.92 m HD (9'7")	2.92 m (9'7")
H120 S	✓	✓	✓	✓	✓
H130 S	✓	✓	✓	✓	✓

HCS70-55 Dedicated Coupler

Undercarriage	L				
Counterweight	6.7 mt				
Boom Type	Reach		Reach HD		VA
Stick Length	2.92 m (9'7")	2.92 m HD (9'7")	2.92 m (9'7")	2.92 m HD (9'7")	2.92 m (9'7")
H120 S	✓	✓	✓	✓	✓
H130 S	✓	✓	✓	✓	✓

HCS70-55 Dedicated Coupler *(continued)*

Undercarriage	L				
Counterweight	8.3 mt				
Boom Type	Reach		Reach HD		VA
Stick Length	2.92 m (9'7")	2.92 m HD (9'7")	2.92 m (9'7")	2.92 m HD (9'7")	2.92 m (9'7")
H120 S	✓	✓	✓	✓	✓
H130 S	✓	✓	✓	✓	✓

HCS70-55 Dedicated Coupler *(continued)*

Undercarriage	L with Blade (up)				
Counterweight	4.9 mt				
Boom Type	Reach		Reach HD		VA
Stick Length	2.92 m (9'7")	2.92 m HD (9'7")	2.92 m (9'7")	2.92 m HD (9'7")	2.92 m (9'7")
H120 S	✓	✓	✓	✓	✓
H130 S	✓	✓	✓	✓	✓

Tilt-Rotator TRS18 with CW30 S Dedicated Coupler

Undercarriage	L				
Counterweight	6.7 mt				
Boom Type	Reach		Reach HD		VA
Stick Length	2.92 m (9'7")	2.92 m HD (9'7")	2.92 m (9'7")	2.92 m HD (9'7")	2.92 m (9'7")
H115 S	✓	✓	✓	✓	✓
H120 S	✓	✓	✓	✓	✓

(continued on next page)

Hammer Technical Specifications

Matching – Tracked Excavators (continued)

Match
 Working Range Front Only
 Allowed Usage on Machine Less Than 50%
 No Match

325 (continued)

Tilt-Rotator TRS18 with CW30 S Dedicated Coupler (continued)

Undercarriage	L				
Counterweight	8.3 mt				
Boom Type	Reach		Reach HD		VA
Stick Length	2.92 m (9'7")	2.92 m HD (9'7")	2.92 m (9'7")	2.92 m HD (9'7")	2.92 m (9'7")
H115 S	✓	✓	✓	✓	✓
H120 S	✓	✓	✓	✓	✓

Tilt-Rotator TRS18 with CW30 S Dedicated Coupler (continued)

Undercarriage	L with Blade (up)				
Counterweight	4.9 mt				
Boom Type	Reach		Reach HD		VA
Stick Length	2.92 m (9'7")	2.92 m HD (9'7")	2.92 m (9'7")	2.92 m HD (9'7")	2.92 m (9'7")
H115 S	✓	✓	✓	✓	✓
H120 S	✓	✓	✓	✓	✓

CW30 S – Tilt-Rotator TRS18 – CW30 S

Undercarriage	L				
Counterweight	6.7 mt				
Boom Type	Reach		Reach HD		VA
Stick Length	2.92 m (9'7")	2.92 m HD (9'7")	2.92 m (9'7")	2.92 m HD (9'7")	2.92 m (9'7")
H115 S	✓	✓	✓	✓	✓
H120 S	✓	✓	✓	✓	✓

CW30 S – Tilt-Rotator TRS18 – CW30 S (continued)

Undercarriage	L				
Counterweight	8.3 mt				
Boom Type	Reach		Reach HD		VA
Stick Length	2.92 m (9'7")	2.92 m HD (9'7")	2.92 m (9'7")	2.92 m HD (9'7")	2.92 m (9'7")
H115 S	✓	✓	✓	✓	✓
H120 S	✓	✓	✓	✓	✓

CW30 S – Tilt-Rotator TRS18 – CW30 S (continued)

Undercarriage	L with Blade (up)				
Counterweight	4.9 mt				
Boom Type	Reach		Reach HD		VA
Stick Length	2.92 m (9'7")	2.92 m HD (9'7")	2.92 m (9'7")	2.92 m HD (9'7")	2.92 m (9'7")
H115 S	✓	✓	✓	✓	✓
H120 S	✓	✓	✓	✓	✓

Tilt-Rotator TRS18 with CW30 Dedicated Coupler

Undercarriage	L				
Counterweight	6.7 mt				
Boom Type	Reach		Reach HD		VA
Stick Length	2.92 m (9'7")	2.92 m HD (9'7")	2.92 m (9'7")	2.92 m HD (9'7")	2.92 m (9'7")
H115 S	✓	✓	✓	✓	✓
H120 S	✓	✓	✓	✓	✓

(continued on next page)

Matching – Tracked Excavators (continued)

Match
 Working Range Front Only
 Allowed Usage on Machine Less Than 50%
 No Match

325 (continued)

Tilt-Rotator TRS18 with CW30 Dedicated Coupler (continued)

Undercarriage	L				
Counterweight	8.3 mt				
Boom Type	Reach		Reach HD		VA
Stick Length	2.92 m (9'7")	2.92 m HD (9'7")	2.92 m (9'7")	2.92 m HD (9'7")	2.92 m (9'7")
H115 S	✓	✓	✓	✓	✓
H120 S	✓	✓	✓	✓	✓

Tilt-Rotator TRS18 with CW30 Dedicated Coupler (continued)

Undercarriage	L with Blade (up)				
Counterweight	4.9 mt				
Boom Type	Reach		Reach HD		VA
Stick Length	2.92 m (9'7")	2.92 m HD (9'7")	2.92 m (9'7")	2.92 m HD (9'7")	2.92 m (9'7")
H115 S	✓	✓	✓	✓	✓
H120 S	✓	✓	✓	✓	

CW30 – Tilt-Rotator TRS18 – CW30

Undercarriage	L				
Counterweight	6.7 mt				
Boom Type	Reach		Reach HD		VA
Stick Length	2.92 m (9'7")	2.92 m HD (9'7")	2.92 m (9'7")	2.92 m HD (9'7")	2.92 m (9'7")
H115 S	✓	✓	✓	✓	✓
H120 S	✓	✓	✓	✓	

CW30 – Tilt-Rotator TRS18 – CW30 (continued)

Undercarriage	L				
Counterweight	8.3 mt				
Boom Type	Reach		Reach HD		VA
Stick Length	2.92 m (9'7")	2.92 m HD (9'7")	2.92 m (9'7")	2.92 m HD (9'7")	2.92 m (9'7")
H115 S	✓	✓	✓	✓	✓
H120 S	✓	✓	✓	✓	✓

CW30 – Tilt-Rotator TRS18 – CW30 (continued)

Undercarriage	L with Blade (up)				
Counterweight	4.9 mt				
Boom Type	Reach		Reach HD		VA
Stick Length	2.92 m (9'7")	2.92 m HD (9'7")	2.92 m (9'7")	2.92 m HD (9'7")	2.92 m (9'7")
H115 S	✓	✓	✓	✓	✓
H120 S					

S70 – Tilt-Rotator TRS18 – S70

Undercarriage	L				
Counterweight	6.7 mt				
Boom Type	Reach		Reach HD		VA
Stick Length	2.92 m (9'7")	2.92 m HD (9'7")	2.92 m (9'7")	2.92 m HD (9'7")	2.92 m (9'7")
H115 S	✓	✓	✓	✓	✓
H120 S	✓	✓	✓	✓	✓

(continued on next page)

Hammer Technical Specifications

Matching – Tracked Excavators *(continued)*

Match
 Working Range Front Only
 Allowed Usage on Machine Less Than 50%
 No Match

325 *(continued)*

S70 – Tilt-Rotator TRS18 – S70 *(continued)*

Undercarriage	L				
Counterweight	8.3 mt				
Boom Type	Reach		Reach HD		VA
Stick Length	2.92 m (9'7")	2.92 m HD (9'7")	2.92 m (9'7")	2.92 m HD (9'7")	2.92 m (9'7")
H115 S	✓	✓	✓	✓	✓
H120 S	✓	✓	✓	✓	✓

S70 – Tilt-Rotator TRS18 – S70 *(continued)*

Undercarriage	L with Blade (up)				
Counterweight	4.9 mt				
Boom Type	Reach		Reach HD		VA
Stick Length	2.92 m (9'7")	2.92 m HD (9'7")	2.92 m (9'7")	2.92 m HD (9'7")	2.92 m (9'7")
H115 S	✓	✓	✓	✓	✓
H120 S	✓	✓	✓		

Tilt-Rotator TRS18 with HCS70-55 Dedicated Coupler

Undercarriage	L					
Counterweight	4.2 mt					
Boom Type	Reach		Reach HD		VA	
Stick Length	2.50 m (8'2")	2.92 m (9'7")	2.50 m HD (8'2")	2.92 m HD (9'7")	2.50 m (8'2")	2.92 m (9'7")
H115 S	✓	✓	✓	✓	✓	✓
H120 S	✓	✓	✓	✓	✓	✓

Tilt-Rotator TRS18 with HCS70-55 Dedicated Coupler *(continued)*

Undercarriage	L					
Counterweight	5.4 mt					
Boom Type	Reach		Reach HD		VA	
Stick Length	2.50 m (8'2")	2.92 m (9'7")	2.50 m HD (8'2")	2.92 m HD (9'7")	2.50 m (8'2")	2.92 m (9'7")
H115 S	✓	✓	✓	✓	✓	✓
H120 S	✓	✓	✓	✓	✓	✓

325 Tunneling

Pin-on

Undercarriage	L	
Counterweight	4.9 mt	
Boom Type	Short Reach	ME
Stick Length	3.20 m (10'6")	2.40 m (7'10")
H120 S	✓	✓
H130 S	✓	✓
H140 S		✓

Cat Pin Grabber Coupler

Undercarriage	L	
Counterweight	4.9 mt	
Boom Type	Short Reach	ME
Stick Length	3.20 m (10'6")	2.40 m (7'10")
H120 S	✓	✓
H130 S	✓	✓

(continued on next page)

Matching – Tracked Excavators *(continued)*

Match
 Working Range Front Only
 Allowed Usage on Machine Less Than 50%
 No Match

325 Tunneling *(continued)*

Tilt-Rotator TRS18 with S70 Dedicated Coupler

Undercarriage	—		L	
Counterweight	4.9 mt		4.9 mt	
Boom Type	Reach	Reach HD	Reach	Reach HD
Stick Length	2.92 m (9'7")	2.92 m HD (9'7")	2.92 m (9'7")	2.92 m HD (9'7")
H115 S	✓	✓	✓	✓
H120 S			✓	✓

Tilt-Rotator TRS18 with S70 Dedicated Coupler *(continued)*

Undercarriage	L					
Counterweight	6.7 mt					
Boom Type	Reach			Reach HD		VA
Stick Length	2.92 m (9'7")	2.92 m HD (9'7")	2.92 m TR (9'7")	2.92 m (9'7")	2.92 m HD (9'7")	2.92 m (9'7")
H115 S	✓	✓	✓	✓	✓	✓
H120 S	✓	✓	✓	✓	✓	✓

Tilt-Rotator TRS18 with S70 Dedicated Coupler *(continued)*

Undercarriage	L					
Counterweight	8.3 mt					
Boom Type	Reach			Reach HD		VA
Stick Length	2.92 m (9'7")	2.92 m HD (9'7")	2.92 m TR (9'7")	2.92 m (9'7")	2.92 m HD (9'7")	2.92 m (9'7")
H115 S	✓	✓	✓	✓	✓	✓
H120 S	✓	✓	✓	✓	✓	✓

Tilt-Rotator TRS18 with S70 Dedicated Coupler *(continued)*

Undercarriage	L with Blade (up)					
Counterweight	4.9 mt					
Boom Type	Reach			Reach HD		VA
Stick Length	2.92 m (9'7")	2.92 m HD (9'7")	2.92 m TR (9'7")	2.92 m (9'7")	2.92 m HD (9'7")	2.92 m (9'7")
H115 S	✓	✓	✓	✓	✓	✓
H120 S	✓	✓	✓	✓	✓	✓

Tilt-Rotator TRS18 with HCS70 Dedicated Coupler

Undercarriage	L				
Counterweight	6.7 mt				
Boom Type	Reach		Reach HD		VA
Stick Length	2.92 m (9'7")	2.92 m HD (9'7")	2.92 m (9'7")	2.92 m HD (9'7")	2.92 m (9'7")
H115 S	✓	✓	✓	✓	✓
H120 S	✓	✓	✓	✓	✓

Tilt-Rotator TRS18 with HCS70 Dedicated Coupler *(continued)*

Undercarriage	L				
Counterweight	8.3 mt				
Boom Type	Reach		Reach HD		VA
Stick Length	2.92 m (9'7")	2.92 m HD (9'7")	2.92 m (9'7")	2.92 m HD (9'7")	2.92 m (9'7")
H115 S	✓	✓	✓	✓	✓
H120 S	✓	✓	✓	✓	✓

(continued on next page)

Hammer Technical Specifications

Matching – Tracked Excavators (continued)

Match
 Working Range Front Only
 Allowed Usage on Machine Less Than 50%
 No Match

325 Tunneling (continued)

Tilt-Rotator TRS18 with HCS70 Dedicated Coupler (continued)

Undercarriage	L with Blade (up)				
Counterweight	4.9 mt				
Boom Type	Reach		Reach HD		VA
Stick Length	2.92 m (9'7")	2.92 m HD (9'7")	2.92 m (9'7")	2.92 m HD (9'7")	2.92 m (9'7")
H115 S	✓	✓	✓	✓	✓
H120 S	✓	✓	✓	✓	

HCS70 – Tilt-Rotator TRS18 – HCS70

Undercarriage	L				
Counterweight	6.7 mt				
Boom Type	Reach		Reach HD		VA
Stick Length	2.92 m (9'7")	2.92 m HD (9'7")	2.92 m (9'7")	2.92 m HD (9'7")	2.92 m (9'7")
H115 S	✓	✓	✓	✓	✓
H120 S	✓	✓	✓	✓	

HCS70 – Tilt-Rotator TRS18 – HCS70 (continued)

Undercarriage	L				
Counterweight	8.3 mt				
Boom Type	Reach		Reach HD		VA
Stick Length	2.92 m (9'7")	2.92 m HD (9'7")	2.92 m (9'7")	2.92 m HD (9'7")	2.92 m (9'7")
H115 S	✓	✓	✓	✓	✓
H120 S	✓	✓	✓	✓	✓

HCS70 – Tilt-Rotator TRS18 – HCS70 (continued)

Undercarriage	L with Blade (up)				
Counterweight	4.9 mt				
Boom Type	Reach		Reach HD		VA
Stick Length	2.92 m (9'7")	2.92 m HD (9'7")	2.92 m (9'7")	2.92 m HD (9'7")	2.92 m (9'7")
H115 S	✓	✓	✓	✓	✓
H120 S					

HCS70-55 – TRS18 – HCS70-55

Undercarriage	L				
Counterweight	6.7 mt				
Boom Type	Reach		Reach HD		VA
Stick Length	2.92 m (9'7")	2.92 m HD (9'7")	2.92 m (9'7")	2.92 m HD (9'7")	2.92 m (9'7")
H115 S	✓	✓	✓	✓	✓

HCS70-55 – TRS18 – HCS70-55 (continued)

Undercarriage	L				
Counterweight	8.3 mt				
Boom Type	Reach		Reach HD		VA
Stick Length	2.92 m (9'7")	2.92 m HD (9'7")	2.92 m (9'7")	2.92 m HD (9'7")	2.92 m (9'7")
H115 S	✓	✓	✓	✓	✓

(continued on next page)

Matching – Tracked Excavators *(continued)*

Match
 Working Range Front Only
 Allowed Usage on Machine Less Than 50%
 No Match

325 Tunneling *(continued)*

HCS70-55 – TRS18 – HCS70-55 *(continued)*

Undercarriage	L with Blade (up)			
Counterweight	4.9 mt			
Boom Type	Reach		Reach HD	
Stick Length	2.92 m (9'7")	2.92 m HD (9'7")	2.92 m (9'7")	2.92 m HD (9'7")
H115 S	✓	✓	✓	✓

326D2

Pin-on

Undercarriage	L		
Counterweight	—		
Boom Type	Reach		Reach HD
Stick Length	2.50 m (8'2")	2.95 m (9'8")	2.95 m HD (9'8")
H120 S	✓	✓	✓
H130 S	✓	✓	✓
H140 S	✓	✓	✓

Cat Pin Grabber Coupler

Undercarriage	L		
Counterweight	—		
Boom Type	Reach		Reach HD
Stick Length	2.50 m (8'2")	2.95 m (9'8")	2.95 m HD (9'8")
H120 S	✓	✓	✓
H130 S	✓	✓	✓
H140 S	✓	✓	✓

CW-40 Dedicated Coupler

Undercarriage	L	
Counterweight	—	
Boom Type	Reach	Reach HD
Stick Length	2.50 m (8'2")	2.95 m HD (9'8")
H120 S	✓	✓
H130 S	✓	✓
H140 S	✓	✓

326F

Pin-on

Undercarriage	L				
Counterweight	—				
Boom Type	Reach HD			VA	
Stick Length	2.50 m HD (8'2")	2.95 m HD (9'8")	3.60 m HD (11'10")	2.50 m HD (8'2")	2.95 m HD (9'8")
H120 S	✓	✓	✓	✓	✓
H130 S	✓	✓	✓	✓	✓
H140 S	✓	✓	✓	✓	✓

(continued on next page)

Hammer Technical Specifications

Matching – Tracked Excavators *(continued)*

Match
 * Working Range Front Only
 † Allowed Usage on Machine Less Than 50%
 No Match

326F *(continued)*

Pin-on *(continued)*

Undercarriage	LN			
Counterweight	—			
Boom Type	Reach HD		VA	
Stick Length	2.50 m HD (8'2")	2.95 m HD (9'8")	2.50 m HD (8'2")	2.95 m HD (9'8")
H120 S	✓	✓	✓	✓
H130 S	✓	✓	✓	✓
H140 S	✓	✓	✓	✓

Cat Pin Grabber Coupler

Undercarriage	L				
Counterweight	—				
Boom Type	Reach HD			VA	
Stick Length	2.50 m HD (8'2")	2.95 m HD (9'8")	3.60 m HD (11'10")	2.50 m HD (8'2")	2.95 m HD (9'8")
H120 S	✓	✓	✓	✓	✓
H130 S	✓	✓	✓	✓	✓
H140 S	✓	✓	✓*	✓	✓

Cat Pin Grabber Coupler *(continued)*

Undercarriage	LN			
Counterweight	—			
Boom Type	Reach HD		VA	
Stick Length	2.50 m HD (8'2")	2.95 m HD (9'8")	2.50 m HD (8'2")	2.95 m HD (9'8")
H120 S	✓	✓	✓	✓
H130 S	✓	✓	✓	✓
H140 S	✓	✓	✓*	

CW-40 Dedicated Coupler

Undercarriage	L				LN			
Counterweight	—				—			
Boom Type	Reach HD		VA		Reach HD		VA	
Stick Length	2.50 m HD (8'2")	2.95 m HD (9'8")	2.50 m HD (8'2")	2.95 m HD (9'8")	2.50 m HD (8'2")	2.95 m HD (9'8")	2.50 m HD (8'2")	2.95 m HD (9'8")
H120 S	✓	✓	✓	✓	✓	✓	✓	✓
H130 S	✓	✓	✓	✓	✓	✓	✓	✓
H140 S	✓	✓	✓	✓	✓	✓	✓	✓*

326 GC

Pin-on

Undercarriage	MID	—	L
Counterweight	4.6 mt	4.6 mt	4.6 mt
Boom Type	Reach	Reach	Reach
Stick Length	2.95 m HD (9'8")	2.95 m (9'8")	2.95 m (9'8")
H120 S	✓	✓	✓
H130 S	✓	✓	✓

(continued on next page)

Hammer Technical Specifications

Matching – Tracked Excavators (continued)

Match
 Working Range Front Only
 Allowed Usage on Machine Less Than 50%
 No Match

326

Pin-on

Undercarriage	L						
Counterweight	4.6 mt						
Boom Type	Reach			Reach HD		VA	
Stick Length	2.50 m (8'2")	2.95 m (9'8")	3.60 m (11'10")	2.50 m (8'2")	2.95 m HD (9'8")	2.50 m (8'2")	2.95 m (9'8")
H120 S	✓	✓	✓	✓	✓	✓	✓
H130 S	✓	✓	✓	✓	✓	✓	✓
H140 S	✓	✓	✓	✓	✓	✓	✓

Pin-on (continued)

Undercarriage	LN				
Counterweight	4.6 mt				
Boom Type	Reach		Reach HD	VA	
Stick Length	2.50 m (8'2")	2.95 m (9'8")	2.95 m HD (9'8")	2.50 m (8'2")	2.95 m (9'8")
H120 S	✓	✓	✓	✓	✓
H130 S	✓	✓	✓	✓	✓
H140 S	✓	✓	✓	✓	✓

Cat Pin Grabber Coupler

Undercarriage	L						
Counterweight	4.6 mt						
Boom Type	Reach			Reach HD		VA	
Stick Length	2.50 m (8'2")	2.95 m (9'8")	3.60 m (11'10")	2.95 m HD (9'8")	2.50 m (8'2")	2.50 m (8'2")	2.95 m (9'8")
H120 S	✓	✓	✓	✓	✓	✓	✓
H130 S	✓	✓	✓	✓	✓	✓	✓
H140 S	✓	✓	✓	✓	✓	✓	✓

Cat Pin Grabber Coupler (continued)

Undercarriage	LN				
Counterweight	4.6 mt				
Boom Type	Reach		Reach HD	VA	
Stick Length	2.50 m (8'2")	2.95 m (9'8")	2.95 m HD (9'8")	2.50 m (8'2")	2.95 m (9'8")
H120 S	✓	✓	✓	✓	✓
H130 S	✓	✓	✓	✓	✓
H140 S	✓	✓	✓*	✓	✓*

CW-40 Dedicated Coupler

Undercarriage	L					
Counterweight	4.6 mt					
Boom Type	Reach		Reach HD		VA	
Stick Length	2.50 m (8'2")	2.95 m (9'8")	2.50 m (8'2")	2.95 m HD (9'8")	2.50 m (8'2")	2.95 m (9'8")
H120 S	✓	✓	✓	✓	✓	✓
H130 S	✓	✓	✓	✓	✓	✓
H140 S	✓	✓	✓	✓	✓	✓

(continued on next page)

Hammer Technical Specifications

Matching – Tracked Excavators (continued)

Match
 * Working Range Front Only
 † Allowed Usage on Machine Less Than 50%
 No Match

326 (continued)

CW-40 Dedicated Coupler (continued)

Undercarriage	LN				
Counterweight	4.6 mt				
Boom Type	Reach		Reach HD	VA	
Stick Length	2.50 m (8'2")	2.95 m (9'8")	2.95 m HD (9'8")	2.50 m (8'2")	2.95 m (9'8")
H120 S	✓	✓	✓	✓	✓
H130 S	✓	✓	✓	✓	✓
H140 S	✓	✓	✓	✓	✓

S70 Dedicated Coupler

Undercarriage	L				
Counterweight	4.6 mt				
Boom Type	Reach		Reach HD	VA	
Stick Length	2.50 m (8'2")	2.95 m (9'8")	2.95 m HD (9'8")	2.50 m (8'2")	2.95 m (9'8")
H120 S	✓	✓	✓	✓	✓
H130 S	✓	✓	✓	✓	✓
H140 S	✓	✓	✓	✓	✓

S70 Dedicated Coupler (continued)

Undercarriage	LN				
Counterweight	4.6 mt				
Boom Type	Reach		Reach HD	VA	
Stick Length	2.50 m (8'2")	2.95 m (9'8")	2.95 m HD (9'8")	2.50 m (8'2")	2.95 m (9'8")
H120 S	✓	✓	✓	✓	✓
H130 S	✓	✓	✓	✓	✓
H140 S	✓	✓	✓	✓	✓

S80 Dedicated Coupler

Undercarriage	L					
Counterweight	4.6 mt					
Boom Type	Reach		Reach HD		VA	
Stick Length	2.50 m (8'2")	2.95 m (9'8")	2.95 m HD (9'8")	2.95 m HD (9'8")	2.50 m (8'2")	2.95 m (9'8")
H120 S	✓	✓	✓	✓	✓	✓
H130 S	✓	✓	✓	✓	✓	✓
H140 S	✓	✓	✓	✓	✓	✓

S80 Dedicated Coupler (continued)

Undercarriage	LN					
Counterweight	4.6 mt					
Boom Type	Reach		Reach HD		VA	
Stick Length	2.50 m (8'2")	2.95 m (9'8")	2.95 m HD (9'8")	2.95 m HD (9'8")	2.50 m (8'2")	2.95 m (9'8")
H120 S	✓	✓	✓	✓	✓	✓
H130 S	✓	✓	✓	✓	✓	✓
H140 S	✓	✓	✓	✓	✓	✓

(continued on next page)

Matching – Tracked Excavators *(continued)*

Match
 Working Range Front Only
 Allowed Usage on Machine Less Than 50%
 No Match

326 *(continued)*

HCS70 Dedicated Coupler

Undercarriage	L				
Counterweight	4.6 mt				
Boom Type	Reach		Reach HD	VA	
Stick Length	2.50 m (8'2")	2.95 m (9'8")	2.95 m HD (9'8")	2.50 m (8'2")	2.95 m (9'8")
H120 S	✓	✓	✓	✓	✓
H130 S	✓	✓	✓	✓	✓
H140 S	✓	✓	✓	✓	✓

HCS70 Dedicated Coupler *(continued)*

Undercarriage	LN				
Counterweight	4.6 mt				
Boom Type	Reach		Reach HD	VA	
Stick Length	2.50 m (8'2")	2.95 m (9'8")	2.95 m HD (9'8")	2.50 m (8'2")	2.95 m (9'8")
H120 S	✓	✓	✓	✓	✓
H130 S	✓	✓	✓	✓	✓
H140 S	✓	✓	✓	✓	✓

HCS70 Dedicated Coupler *(continued)*

Undercarriage	L				
Counterweight	4.6 mt				
Boom Type	Reach		Reach HD	VA	
Stick Length	2.50 m (8'2")	2.95 m (9'8")	2.95 m HD (9'8")	2.50 m (8'2")	2.95 m (9'8")
H120 S	✓	✓	✓	✓	✓
H130 S	✓	✓	✓	✓	✓
H140 S	✓	✓	✓	✓	✓

HCS70 Dedicated Coupler *(continued)*

Undercarriage	LN				
Counterweight	4.6 mt				
Boom Type	Reach		Reach HD	VA	
Stick Length	2.50 m (8'2")	2.95 m (9'8")	2.95 m HD (9'8")	2.50 m (8'2")	2.95 m (9'8")
H120 S	✓	✓	✓	✓	✓
H130 S	✓	✓	✓	✓	✓
H140 S	✓	✓	✓	✓	✓

HCS70-55 Dedicated Coupler

Undercarriage	L				
Counterweight	4.6 mt				
Boom Type	Reach		Reach HD	VA	
Stick Length	2.50 m (8'2")	2.95 m (9'8")	2.95 m HD (9'8")	2.50 m (8'2")	2.95 m (9'8")
H120 S	✓	✓	✓	✓	✓
H130 S	✓	✓	✓	✓	✓
H140 S	✓	✓	✓	✓	✓

(continued on next page)

Hammer Technical Specifications

Matching – Tracked Excavators *(continued)*

Match
 * Working Range Front Only
 † Allowed Usage on Machine Less Than 50%
 No Match

326 *(continued)*

HCS70-55 Dedicated Coupler *(continued)*

Undercarriage	LN				
Counterweight	4.6 mt				
Boom Type	Reach		Reach HD	VA	
Stick Length	2.50 m (8'2")	2.95 m (9'8")	2.95 m HD (9'8")	2.50 m (8'2")	2.95 m (9'8")
H120 S	✓	✓	✓	✓	✓
H130 S	✓	✓	✓	✓	✓
H140 S	✓	✓	✓	✓	✓

HCS80 Dedicated Coupler

Undercarriage	L				
Counterweight	4.6 mt				
Boom Type	Reach		Reach HD	VA	
Stick Length	2.50 m (8'2")	2.95 m (9'8")	2.95 m HD (9'8")	2.50 m (8'2")	2.95 m (9'8")
H120 S	✓	✓	✓	✓	✓
H130 S	✓	✓	✓	✓	✓
H140 S	✓	✓	✓	✓	✓

HCS80 Dedicated Coupler *(continued)*

Undercarriage	LN				
Counterweight	4.6 mt				
Boom Type	Reach		Reach HD	VA	
Stick Length	2.50 m (8'2")	2.95 m (9'8")	2.95 m HD (9'8")	2.50 m (8'2")	2.95 m (9'8")
H120 S	✓	✓	✓	✓	✓
H130 S	✓	✓	✓	✓	✓
H140 S	✓	✓	✓	✓	✓

Tilt-Rotator TRS23 with CW40 Dedicated Coupler

Undercarriage	L					
Counterweight	4.6 mt					
Boom Type	Reach		Reach HD		VA	
Stick Length	2.50 m (8'2")	2.95 m (9'8")	2.95 m HD (9'8")	2.95 m HD (9'8")	2.50 m (8'2")	2.95 m (9'8")
H120 S	✓	✓	✓	✓	✓	✓
H130 S	✓	✓	✓	✓	✓	✓

Tilt-Rotator TRS23 with CW40 Dedicated Coupler *(continued)*

Undercarriage	LN					
Counterweight	4.6 mt					
Boom Type	Reach		Reach HD		VA	
Stick Length	2.50 m (8'2")	2.95 m (9'8")	2.95 m HD (9'8")	2.95 m HD (9'8")	2.50 m (8'2")	2.95 m (9'8")
H120 S	✓	✓	✓	✓	✓	✓
H130 S	✓	✓	✓	✓	✓	✓

(continued on next page)

Matching – Tracked Excavators *(continued)*

Match
 Working Range Front Only
 Allowed Usage on Machine Less Than 50%
 No Match

326 *(continued)*

CW40 – TRS23 – CW40

Undercarriage	L				
Counterweight	4.6 mt				
Boom Type	Reach		Reach HD	VA	
Stick Length	2.50 m (8'2")	2.95 m (9'8")	2.95 m HD (9'8")	2.50 m (8'2")	2.95 m (9'8")
H120 S	✓	✓	✓	✓	✓
H130 S	✓	✓	✓	✓	✓

CW40 – TRS23 – CW40 *(continued)*

Undercarriage	LN				
Counterweight	4.6 mt				
Boom Type	Reach		Reach HD	VA	
Stick Length	2.50 m (8'2")	2.95 m (9'8")	2.95 m HD (9'8")	2.50 m (8'2")	2.95 m (9'8")
H120 S	✓	✓	✓	✓	✓
H130 S	✓				

Tilt-Rotator TRS23 with CW45 S Dedicated Coupler

Undercarriage	L				
Counterweight	4.6 mt				
Boom Type	Reach		Reach HD	VA	
Stick Length	2.50 m (8'2")	2.50 m (8'2")	2.50 m (8'2")	2.50 m (8'2")	2.50 m (8'2")
H120 S	✓	✓	✓	✓	✓
H130 S	✓	✓	✓	✓	✓

Tilt-Rotator TRS23 with CW45 S Dedicated Coupler *(continued)*

Undercarriage	LN				
Counterweight	4.6 mt				
Boom Type	Reach		Reach HD	VA	
Stick Length	2.50 m (8'2")	2.50 m (8'2")	2.50 m (8'2")	2.50 m (8'2")	2.50 m (8'2")
H120 S	✓	✓	✓	✓	✓
H130 S	✓	✓	✓	✓	

Tilt-Rotator TRS23 with S70 Dedicated Coupler

Undercarriage	L					
Counterweight	4.6 mt					
Boom Type	Reach			Reach HD	VA	
Stick Length	2.50 m (8'2")	2.95 m (9'8")	3.60 m (11'10")	2.95 m HD (9'8")	2.50 m (8'2")	2.95 m (9'8")
H120 S	✓	✓	✓	✓	✓	✓
H130 S	✓	✓	✓	✓	✓	✓

Tilt-Rotator TRS23 with S70 Dedicated Coupler *(continued)*

Undercarriage	LN				
Counterweight	4.6 mt				
Boom Type	Reach		Reach HD	VA	
Stick Length	2.50 m (8'2")	2.95 m (9'8")	2.95 m HD (9'8")	2.50 m (8'2")	2.95 m (9'8")
H120 S	✓	✓	✓	✓	✓
H130 S	✓	✓	✓	✓	✓

(continued on next page)

Hammer Technical Specifications

Matching – Tracked Excavators (continued)

Match
 Working Range Front Only
 Allowed Usage on Machine Less Than 50%
 No Match

326 (continued)

S70 – TRS23 – S70

Undercarriage	L					
Counterweight	4.6 mt					
Boom Type	Reach		Reach HD		VA	
Stick Length	2.50 m (8'2")	2.95 m (9'8")	2.95 m HD (9'8")	2.95 m HD (9'8")	2.50 m (8'2")	2.95 m (9'8")
H120 S	✓	✓	✓	✓	✓	✓
H130 S	✓	✓	✓	✓	✓	✓

S70 – TRS23 – S70 (continued)

Undercarriage	LN					
Counterweight	4.6 mt					
Boom Type	Reach		Reach HD		VA	
Stick Length	2.50 m (8'2")	2.95 m (9'8")	2.95 m HD (9'8")	2.95 m HD (9'8")	2.50 m (8'2")	2.95 m (9'8")
H120 S	✓	✓	✓	✓	✓	✓
H130 S	✓	✓	✓	✓	✓	✓

Tilt-Rotator TRS23 with S80 Dedicated Coupler

Undercarriage	L					
Counterweight	4.6 mt					
Boom Type	Reach		Reach HD	VA		
Stick Length	2.50 m (8'2")	2.95 m (9'8")	3.60 m (11'10")	2.95 m HD (9'8")	2.50 m (8'2")	2.95 m (9'8")
H120 S	✓	✓	✓	✓	✓	✓
H130 S	✓	✓	✓	✓	✓	✓

Tilt-Rotator TRS23 with S80 Dedicated Coupler (continued)

Undercarriage	LN					
Counterweight	4.6 mt					
Boom Type	Reach		Reach HD	VA		
Stick Length	2.50 m (8'2")	2.95 m (9'8")	2.95 m HD (9'8")	2.50 m (8'2")	2.95 m (9'8")	
H120 S	✓	✓	✓	✓	✓	
H130 S	✓	✓	✓	✓	✓	

S80 – TRS23 – S80

Undercarriage	L			LN		
Counterweight	4.6 mt			4.6 mt		
Boom Type	Reach	Reach HD	VA	Reach	Reach HD	VA
Stick Length	2.50 m (8'2")	2.50 m (8'2")	2.50 m (8'2")	2.50 m (8'2")	2.50 m (8'2")	2.50 m (8'2")
H120 S	✓	✓	✓	✓	✓	✓
H130 S	✓	✓	✓			

HCS70 – TRS23 – HCS70

Undercarriage	L					
Counterweight	4.6 mt					
Boom Type	Reach		Reach HD	VA		
Stick Length	2.50 m (8'2")	2.95 m (9'8")	2.95 m HD (9'8")	2.50 m (8'2")	2.95 m (9'8")	
H120 S	✓	✓	✓	✓	✓	
H130 S	✓	✓	✓	✓	✓	

(continued on next page)

Matching – Tracked Excavators *(continued)*

Match
 Working Range Front Only
 Allowed Usage on Machine Less Than 50%
 No Match

326 *(continued)*

HCS70 – TRS23 – HCS70 *(continued)*

Undercarriage	LN				
Counterweight	4.6 mt				
Boom Type	Reach		Reach HD	VA	
Stick Length	2.50 m (8'2")	2.95 m (9'8")	2.95 m HD (9'8")	2.50 m (8'2")	2.95 m (9'8")
H120 S	✓	✓	✓	✓	✓
H130 S	✓				

HCS70-55 – TRS23 – HCS70-55

Undercarriage	L				
Counterweight	4.6 mt				
Boom Type	Reach		Reach HD	VA	
Stick Length	2.50 m (8'2")	2.95 m (9'8")	2.95 m HD (9'8")	2.50 m (8'2")	2.95 m (9'8")
H120 S	✓	✓	✓	✓	✓
H130 S	✓	✓	✓	✓	✓

HCS70-55 – TRS23 – HCS70-55 *(continued)*

Undercarriage	LN				
Counterweight	4.6 mt				
Boom Type	Reach		Reach HD	VA	
Stick Length	2.50 m (8'2")	2.95 m (9'8")	2.95 m HD (9'8")	2.50 m (8'2")	2.95 m (9'8")
H120 S	✓	✓	✓	✓	✓
H130 S	✓				

HCS80 – TRS23 – HCS80

Undercarriage	L					LN
Counterweight	4.6 mt					4.6 mt
Boom Type	Reach		Reach HD	VA		Reach
Stick Length	2.50 m (8'2")	2.95 m (9'8")	2.95 m HD (9'8")	2.50 m (8'2")	2.95 m (9'8")	2.50 m (8'2")
H120 S	✓	✓	✓	✓	✓	✓
H130 S	✓	✓		✓		

330D2

Pin-on

Undercarriage	L			
Counterweight	—			
Boom Type	Reach	Reach HD		ME
Stick Length	2.65 m (8'8")	2.65 m HD (8'8")	3.20 m HD (10'6")	2.50 m (8'2")
H120 S	✓	✓	✓	
H130 S	✓	✓	✓	✓
H140 S	✓	✓	✓	✓

(continued on next page)

Hammer Technical Specifications

Matching – Tracked Excavators (continued)

Match
 Working Range Front Only
 Allowed Usage on Machine Less Than 50%
 No Match

330D2 (continued)

Cat Pin Grabber Coupler

Undercarriage	L			
Counterweight	—			
Boom Type	Reach	Reach HD		ME
Stick Length	2.65 m (8'8")	2.65 m HD (8'8")	3.20 m HD (10'6")	2.50 m (8'2")
H120 S	✓	✓	✓	
H130 S	✓	✓	✓	✓
H140 S	✓	✓	✓	✓

CW-45 S Dedicated Coupler

Undercarriage	L			
Counterweight	—			
Boom Type	Reach	Reach HD		ME
Stick Length	2.65 m (8'8")	2.65 m HD (8'8")	3.20 m HD (10'6")	2.50 m (8'2")
H120 S	✓	✓	✓	
H130 S	✓	✓	✓	✓
H140 S	✓	✓	✓	✓

CW-45 Dedicated Coupler

Undercarriage	L			
Counterweight	—			
Boom Type	Reach	Reach HD		ME
Stick Length	2.65 m (8'8")	2.65 m HD (8'8")	3.20 m HD (10'6")	2.50 m (8'2")
H120 S	✓	✓	✓	
H130 S	✓	✓	✓	✓
H140 S	✓	✓	✓	✓

330F

Pin-on

Undercarriage	L				LN	
Counterweight	—				—	
Boom Type	Reach ES	Reach HD			Reach HD	
Stick Length	3.20 m ES (10'6")	2.65 m HD (8'8")	3.20 m HD (10'6")	3.75 m HD (12'4")	2.65 m HD (8'8")	3.20 m HD (10'6")
H120 S	✓	✓	✓	✓	✓	✓
H130 S	✓	✓	✓	✓	✓	✓
H140 S	✓	✓	✓	✓	✓	✓

Cat Pin Grabber Coupler

Undercarriage	L			LN	
Counterweight	—			—	
Boom Type	Reach HD			Reach HD	
Stick Length	2.65 m HD (8'8")	3.20 m HD (10'6")	3.75 m HD (12'4")	2.65 m HD (8'8")	3.20 m HD (10'6")
H120 S	✓	✓	✓	✓	✓
H130 S	✓	✓	✓	✓	✓
H140 S	✓	✓	✓	✓	✓

(continued on next page)

Matching – Tracked Excavators *(continued)*

Match
 Working Range Front Only
 Allowed Usage on Machine Less Than 50%
 No Match

330F *(continued)*

CW-45 S Dedicated Coupler

Undercarriage	L		LN	
Counterweight	—		—	
Boom Type	Reach HD		Reach HD	
Stick Length	2.65 m HD (8'8")	3.20 m HD (10'6")	2.65 m HD (8'8")	3.20 m HD (10'6")
H120 S	✓	✓	✓	✓
H130 S	✓	✓	✓	✓
H140 S	✓	✓	✓	✓

CW-45 Dedicated Coupler

Undercarriage	L		LN	
Counterweight	—		—	
Boom Type	Reach HD		Reach HD	
Stick Length	2.65 m HD (8'8")	3.20 m HD (10'6")	2.65 m HD (8'8")	3.20 m HD (10'6")
H120 S	✓	✓	✓	✓
H130 S	✓	✓	✓	✓
H140 S	✓	✓	✓	✓

330 GC

Pin-on

Undercarriage	—					
Counterweight	5.8 mt			6.7 mt		
Boom Type	Reach		ME	Reach		ME
Stick Length	2.65 m (8'8")	3.20 m (10'6")	2.50 m (8'2")	2.65 m (8'8")	3.20 m (10'6")	2.50 m (8'2")
H120 S	✓	✓	✓	✓	✓	✓
H130 S	✓	✓	✓	✓	✓	✓
H140 S	✓	✓	✓	✓	✓	✓

Pin-on *(continued)*

Undercarriage	L		
Counterweight	6.7 mt		
Boom Type	Reach		ME
Stick Length	2.65 m (8'8")	3.20 m (10'6")	2.50 m (8'2")
H120 S	✓	✓	
H130 S	✓	✓	
H140 S	✓	✓	

Cat Pin Grabber Coupler

Undercarriage	—						L	
Counterweight	5.8 mt			6.7 mt			6.7 mt	
Boom Type	Reach		ME	Reach		ME	Reach	
Stick Length	2.65 m (8'8")	3.20 m (10'6")	2.50 m (8'2")	2.65 m (8'8")	3.20 m (10'6")	2.50 m (8'2")	2.65 m (8'8")	3.20 m (10'6")
H120 S	✓	✓	✓	✓	✓	✓	✓	✓
H130 S	✓	✓	✓	✓	✓	✓	✓	✓
H140 S	✓	✓	✓	✓	✓	✓	✓	✓

(continued on next page)

Hammer Technical Specifications

Matching – Tracked Excavators (continued)

Match
 * Working Range Front Only
 † Allowed Usage on Machine Less Than 50%
 No Match

330 GC (continued)

CW-45 S Dedicated Coupler

Undercarriage	—						L	
Counterweight	5.8 mt			6.7 mt			6.7 mt	
Boom Type	Reach		ME	Reach		ME	Reach	
Stick Length	2.65 m (8'8")	3.20 m (10'6")	2.50 m (8'2")	2.65 m (8'8")	3.20 m (10'6")	2.50 m (8'2")	2.65 m (8'8")	3.20 m (10'6")
H120 S	✓	✓	✓	✓	✓	✓	✓	✓
H130 S	✓	✓	✓	✓	✓	✓	✓	✓
H140 S	✓	✓	✓	✓	✓	✓	✓	✓

CW-45 Dedicated Coupler

Undercarriage	—						L	
Counterweight	5.8 mt			6.7 mt			6.7 mt	
Boom Type	Reach		ME	Reach		ME	Reach	
Stick Length	2.65 m (8'8")	3.20 m (10'6")	2.50 m (8'2")	2.65 m (8'8")	3.20 m (10'6")	2.50 m (8'2")	2.65 m (8'8")	3.20 m (10'6")
H120 S	✓	✓	✓	✓	✓	✓	✓	✓
H130 S	✓	✓	✓	✓	✓	✓	✓	✓
H140 S	✓	✓	✓	✓	✓	✓	✓	✓

330

Pin-on

Undercarriage	L						LN	
Counterweight	6.7 mt						6.7 mt	
Boom Type	Reach			Reach HD		ME	Reach	
Stick Length	2.65 m (8'8")	3.75 m (12'4")	3.20 m (10'6")	2.65 m HD (8'8")	3.20 m HD (10'6")	2.50 m (8'2")	2.65 m (8'8")	3.20 m (10'6")
H120 S	✓	✓	✓	✓	✓	✓	✓	✓
H130 S	✓	✓	✓	✓	✓	✓	✓	✓
H140 S	✓	✓	✓	✓	✓	✓	✓	✓

Cat Pin Grabber Coupler

Undercarriage	L						LN	
Counterweight	6.7 mt						6.7 mt	
Boom Type	Reach			Reach HD		ME	Reach	
Stick Length	2.65 m (8'8")	3.75 m (12'4")	3.20 m (10'6")	2.65 m HD (8'8")	3.20 m HD (10'6")	2.50 m (8'2")	2.65 m (8'8")	3.20 m (10'6")
H120 S	✓	✓	✓	✓	✓	✓	✓	✓
H130 S	✓	✓	✓	✓	✓	✓	✓	✓
H140 S	✓	✓	✓	✓	✓	✓	✓	✓

CW-45 S Dedicated Coupler

Undercarriage	L					LN	
Counterweight	6.7 mt					6.7 mt	
Boom Type	Reach		Reach HD		ME	Reach	
Stick Length	2.65 m (8'8")	3.20 m (10'6")	2.65 m HD (8'8")	3.20 m HD (10'6")	2.50 m (8'2")	2.65 m (8'8")	3.20 m (10'6")
H115 S	✓	✓	✓	✓	✓	✓	✓
H120 S	✓	✓	✓	✓	✓	✓	✓
H130 S	✓	✓	✓	✓	✓	✓	✓
H140 S	✓	✓	✓	✓	✓	✓	✓

(continued on next page)

Matching – Tracked Excavators (continued)

Match
 * Working Range Front Only
 † Allowed Usage on Machine Less Than 50%
 No Match

330 (continued)

CW-45 Dedicated Coupler

Undercarriage	L				LN		
Counterweight	6.7 mt				6.7 mt		
Boom Type	Reach		Reach HD		ME	Reach	
Stick Length	2.65 m (8'8")	3.20 m (10'6")	2.65 m HD (8'8")	3.20 m HD (10'6")	2.50 m (8'2")	2.65 m (8'8")	3.20 m (10'6")
H120 S	✓	✓	✓	✓	✓	✓	✓
H130 S	✓	✓	✓	✓	✓	✓	✓
H140 S	✓	✓	✓	✓	✓	✓	✓

S70 Dedicated Coupler

Undercarriage	L		LN	
Counterweight	6.7 mt		6.7 mt	
Boom Type	Reach		Reach	
Stick Length	2.65 m (8'8")	3.20 m (10'6")	2.65 m (8'8")	3.20 m (10'6")
H120 S	✓	✓	✓	✓
H130 S	✓	✓	✓	✓
H140 S	✓	✓	✓	✓

S80 Dedicated Coupler

Undercarriage	L		LN	
Counterweight	6.7 mt		6.7 mt	
Boom Type	Reach		Reach	
Stick Length	2.65 m (8'8")	3.20 m (10'6")	2.65 m (8'8")	3.20 m (10'6")
H120 S	✓	✓	✓	✓
H130 S	✓	✓	✓	✓
H140 S	✓	✓	✓	✓

HCS70 Dedicated Coupler

Undercarriage	L		LN	
Counterweight	6.7 mt		6.7 mt	
Boom Type	Reach		Reach	
Stick Length	2.65 m (8'8")	3.20 m (10'6")	2.65 m (8'8")	3.20 m (10'6")
H120 S	✓	✓	✓	✓
H130 S	✓	✓	✓	✓

HCS70-55 Dedicated Coupler

Undercarriage	L		LN	
Counterweight	6.7 mt		6.7 mt	
Boom Type	Reach		Reach	
Stick Length	2.65 m (8'8")	3.20 m (10'6")	2.65 m (8'8")	3.20 m (10'6")
H120 S	✓	✓	✓	✓
H130 S	✓	✓	✓	✓
H140 S	✓	✓	✓	✓

(continued on next page)

Hammer Technical Specifications

Matching – Tracked Excavators (continued)

Match
 * Working Range Front Only
 † Allowed Usage on Machine Less Than 50%
 No Match

330 (continued)

HCS80 Dedicated Coupler

Undercarriage	L		LN	
Counterweight	6.7 mt		6.7 mt	
Boom Type	Reach		Reach	
Stick Length	2.65 m (8'8")	3.20 m (10'6")	2.65 m (8'8")	3.20 m (10'6")
H120 S	✓	✓	✓	✓
H130 S	✓	✓	✓	✓
H140 S	✓	✓	✓	✓

Tilt-Rotator TRS23 with CW40 Dedicated Coupler

Undercarriage	L		LN	
Counterweight	6.7 mt		6.7 mt	
Boom Type	Reach		Reach	
Stick Length	2.65 m (8'8")	3.20 m (10'6")	2.65 m (8'8")	3.20 m (10'6")
H120 S	✓	✓	✓	✓
H130 S	✓	✓	✓	✓

Tilt-Rotator TRS23 with CW45 S Dedicated Coupler

Undercarriage	L	LN
Counterweight	6.7 mt	6.7 mt
Boom Type	Reach	Reach
Stick Length	2.50 m (8'2")	2.50 m (8'2")
H120 S	✓	✓
H130 S	✓	✓

CW45 S – TRS23 – CW45 S

Undercarriage	L		LN	
Counterweight	6.7 mt		6.7 mt	
Boom Type	Reach		Reach	
Stick Length	2.50 m (8'2")	2.50 m (8'2")	2.50 m (8'2")	2.50 m (8'2")
H120 S	✓	✓	✓	✓
H130 S	✓	✓	✓	✓

Tilt-Rotator TRS23 with S70 Dedicated Coupler

Undercarriage	L				LN		
Counterweight	6.7 mt				6.7 mt		
Boom Type	Reach		Reach HD		Reach		
Stick Length	2.65 m (8'8")	3.20 m (10'6")	3.75 m (12'4")	2.65 m HD (8'8")	3.20 m HD (10'6")	2.65 m (8'8")	3.20 m (10'6")
H120 S	✓	✓	✓	✓	✓	✓	✓
H130 S	✓	✓	✓	✓	✓	✓	✓

S70 – TRS23 – S70

Undercarriage	L		LN	
Counterweight	6.7 mt		6.7 mt	
Boom Type	Reach		Reach	
Stick Length	2.65 m (8'8")	3.20 m (10'6")	2.65 m (8'8")	3.20 m (10'6")
H120 S	✓	✓	✓	✓
H130 S	✓	✓	✓	✓

(continued on next page)

Matching – Tracked Excavators *(continued)*

Match
 Working Range Front Only
 Allowed Usage on Machine Less Than 50%
 No Match

330 *(continued)*

Tilt-Rotator TRS23 with S80 Dedicated Coupler

Undercarriage	L				LN		LN	
Counterweight	6.7 mt				6.7 mt		6.7 mt	
Boom Type	Reach				Reach HD		Reach	
Stick Length	2.65 m (8'8")	2.65 m (8'8")	3.20 m (10'6")	3.75 m (12'4")	2.65 m HD (8'8")	3.20 m HD (10'6")	2.65 m (8'8")	3.20 m (10'6")
H120 S	✓	✓	✓	✓	✓	✓	✓	✓
H130 S	✓	✓	✓	✓	✓	✓	✓	✓

S80 – TRS23 – S80

Undercarriage	L	LN
Counterweight	6.7 mt	6.7 mt
Boom Type	Reach	Reach
Stick Length	2.50 m (8'2")	2.50 m (8'2")
H120 S	✓	✓
H130 S	✓	✓

HCS70 – TRS23 – HCS70

Undercarriage	L		LN	
Counterweight	6.7 mt		6.7 mt	
Boom Type	Reach		Reach	
Stick Length	2.65 m (8'8")	3.20 m (10'6")	2.65 m (8'8")	3.20 m (10'6")
H120 S	✓	✓	✓	✓
H130 S	✓	✓	✓	✓

HCS80 – TRS23 – HCS80

Undercarriage	L		LN	
Counterweight	6.7 mt		6.7 mt	
Boom Type	Reach		Reach	
Stick Length	2.65 m (8'8")	3.20 m (10'6")	2.65 m (8'8")	3.20 m (10'6")
H120 S	✓	✓	✓	✓
H130 S	✓	✓	✓	✓

333

Pin-on

Undercarriage	L	
Counterweight	7.7 mt	
Boom Type	Reach	
Stick Length	2.80 m (9'2")	3.20 m (10'6")
H130 S	✓	✓
H140 S	✓	✓
H160 S	✓	✓
H180 S	✓	✓

(continued on next page)

Hammer Technical Specifications

Matching – Tracked Excavators *(continued)*

Match
 Working Range Front Only
 Allowed Usage on Machine Less Than 50%
 No Match

333 *(continued)*

Cat Pin Grabber Coupler

Undercarriage	L	
Counterweight	7.7 mt	
Boom Type	Reach	
Stick Length	2.80 m (9'2")	3.20 m (10'6")
H130 S	✓	✓
H140 S	✓	✓
H160 S	✓	✓
H180 S	✓*	

CW-45 S Dedicated Coupler

Undercarriage	L	
Counterweight	7.7 mt	
Boom Type	Reach	
Stick Length	2.80 m (9'2")	3.20 m (10'6")
H120 S	✓	✓
H130 S	✓	✓
H160 S	✓	✓
H180 S	✓	

CW-45 Dedicated Coupler

Undercarriage	L	
Counterweight	7.7 mt	
Boom Type	Reach	
Stick Length	2.80 m (9'2")	3.20 m (10'6")
H130 S	✓	✓
H140 S	✓	✓
H160 S	✓	✓
H180 S	✓	

HCS70-55 – TRS23 – HCS70-55

Undercarriage	L		LN	
Counterweight	6.7 mt		6.7 mt	
Boom Type	Reach		Reach	
Stick Length	2.65 m (8'8")	3.20 m (10'6")	2.65 m (8'8")	3.20 m (10'6")
H120 S	✓	✓	✓	✓
H130 S	✓	✓	✓	✓

335F CR

Pin-on

Undercarriage	L		
Counterweight	—		
Boom Type	Reach HD		
Stick Length	2.65 m HD (8'8")	3.20 m HD (10'6")	3.75 m HD (12'4")
H120 S	✓	✓	✓
H130 S	✓	✓	✓
H140 S	✓	✓	✓

(continued on next page)

Matching – Tracked Excavators *(continued)*

Match
 Working Range Front Only
 Allowed Usage on Machine Less Than 50%
 No Match

335F CR *(continued)*

Cat Pin Grabber Coupler

Undercarriage	L		
Counterweight	—		
Boom Type	Reach HD		
Stick Length	2.65 m HD (8'8")	3.20 m HD (10'6")	3.75 m HD (12'4")
H120 S	✓	✓	✓
H130 S	✓	✓	✓
H140 S	✓	✓	✓

CW-45 S Dedicated Coupler

Undercarriage	L	
Counterweight	—	
Boom Type	Reach HD	
Stick Length	2.65 m HD (8'8")	3.20 m HD (10'6")
H120 S	✓	✓
H130 S	✓	✓
H140 S	✓	✓

CW-45 Dedicated Coupler

Undercarriage	L	
Counterweight	—	
Boom Type	Reach HD	
Stick Length	2.65 m HD (8'8")	3.20 m HD (10'6")
H120 S	✓	✓
H130 S	✓	✓
H140 S	✓	✓

335

Pin-on

Undercarriage	L		L with Blade (up)	
Counterweight	7.7 mt		5.0 mt	
Boom Type	Reach		Reach	
Stick Length	3.20 m (10'6")	3.75 m (12'4")	3.20 m (10'6")	3.75 m (12'4")
H130 S	✓	✓	✓	✓
H140 S	✓	✓	✓	✓

Cat Pin Grabber Coupler

Undercarriage	L		L with Blade (up)	
Counterweight	7.7 mt		5.0 mt	
Boom Type	Reach		Reach	
Stick Length	3.20 m (10'6")	3.75 m (12'4")	3.20 m (10'6")	3.75 m (12'4")
H130 S	✓	✓	✓	✓
H140 S	✓	✓	✓	✓

(continued on next page)

Hammer Technical Specifications

Matching – Tracked Excavators *(continued)*

Match
 * Working Range Front Only
 † Allowed Usage on Machine Less Than 50%
 No Match

335 *(continued)*

CW-45 S Dedicated Coupler

Undercarriage	L with Blade (up)	
Counterweight	5.0 mt	
Boom Type	Reach	
Stick Length	3.20 m (10'6")	3.75 m (12'4")
H120 S	✓	✓
H130 S	✓	✓

CW-45 Dedicated Coupler

Undercarriage	L	L with Blade (up)	
Counterweight	7.7 mt	5.0 mt	
Boom Type	Reach		Reach
Stick Length	3.75 m (12'4")	3.20 m (10'6")	3.75 m (12'4")
H130 S	✓	✓	✓
H140 S	✓	✓	✓

S70 Dedicated Coupler

Undercarriage	L		L with Blade (up)	
Counterweight	7.7 mt		5.0 mt	
Boom Type	Reach		Reach	
Stick Length	3.20 m (10'6")	3.75 m (12'4")	3.20 m (10'6")	3.75 m (12'4")
H130 S	✓	✓	✓	✓
H140 S	✓	✓	✓	✓

S80 Dedicated Coupler

Undercarriage	L		L with Blade (up)	
Counterweight	7.7 mt		5.0 mt	
Boom Type	Reach		Reach	
Stick Length	3.20 m (10'6")	3.75 m (12'4")	3.20 m (10'6")	3.75 m (12'4")
H130 S	✓	✓	✓	✓
H140 S	✓	✓	✓	✓

HCS70 Dedicated Coupler

Undercarriage	L		L with Blade (up)	
Counterweight	7.7 mt		5.0 mt	
Boom Type	Reach		Reach	
Stick Length	3.20 m (10'6")	3.75 m (12'4")	3.20 m (10'6")	3.75 m (12'4")
H130 S	✓	✓	✓	✓

HCS70-55 Dedicated Coupler

Undercarriage	L		L with Blade (up)	
Counterweight	7.7 mt		5.0 mt	
Boom Type	Reach		Reach	
Stick Length	3.20 m (10'6")	3.75 m (12'4")	3.20 m (10'6")	3.75 m (12'4")
H130 S	✓	✓	✓	✓
H140 S	✓	✓	✓	✓

(continued on next page)

Matching – Tracked Excavators *(continued)*

Match
 Working Range Front Only
 Allowed Usage on Machine Less Than 50%
 No Match

335 *(continued)*

HCS80 Dedicated Coupler

Undercarriage	L		L with Blade (up)	
Counterweight	7.7 mt		5.0 mt	
Boom Type	Reach		Reach	
Stick Length	3.20 m (10'6")	3.75 m (12'4")	3.20 m (10'6")	3.75 m (12'4")
H130 S	✓	✓	✓	✓
H140 S	✓	✓	✓	✓

Tilt-Rotator TRS23 with CW40 Dedicated Coupler

Undercarriage	L		L with Blade (up)	
Counterweight	7.7 mt		5.0 mt	
Boom Type	Reach		Reach	
Stick Length	3.20 m (10'6")	3.75 m (12'4")	3.20 m (10'6")	3.75 m (12'4")
H120 S	✓	✓	✓	✓
H130 S	✓	✓	✓	✓

Tilt-Rotator TRS23 with CW45 S Dedicated Coupler

Undercarriage	L	L with Blade (up)
Counterweight	7.7 mt	5.0 mt
Boom Type	Reach	Reach
Stick Length	2.50 m (8'2")	2.50 m (8'2")
H120 S	✓	✓
H130 S	✓	✓

CW45 S – TRS23 – CW45 S

Undercarriage	L				LN		
Counterweight	4.6 mt				4.6 mt		
Boom Type	Reach		Reach HD	VA		Reach	VA
Stick Length	2.50 m (8'2")	2.50 m (8'2")	2.50 m (8'2")	2.50 m (8'2")	2.50 m (8'2")	2.50 m (8'2")	2.50 m (8'2")
H120 S	✓	✓	✓	✓	✓	✓	✓
H130 S	✓	✓		✓			

CW45 S – TRS23 – CW45 S

Undercarriage	L	L with Blade (up)
Counterweight	7.7 mt	5.0 mt
Boom Type	Reach	Reach
Stick Length	2.50 m (8'2")	2.50 m (8'2")
H120 S	✓	✓
H130 S	✓	

Tilt-Rotator TRS23 with S70 Dedicated Coupler

Undercarriage	L		L with Blade (up)	
Counterweight	7.7 mt		5.0 mt	
Boom Type	Reach		Reach	
Stick Length	3.20 m (10'6")	3.75 m (12'4")	3.20 m (10'6")	3.75 m (12'4")
H120 S	✓	✓	✓	✓
H130 S	✓	✓	✓	✓

(continued on next page)

Hammer Technical Specifications

Matching – Tracked Excavators (continued)

Match
 * Working Range Front Only
 † Allowed Usage on Machine Less Than 50%
 No Match

335 (continued)

S70 – TRS23 – S70

Undercarriage	L		L with Blade (up)	
Counterweight	7.7 mt		5.0 mt	
Boom Type	Reach		Reach	
Stick Length	3.20 m (10'6")	3.75 m (12'4")	3.20 m (10'6")	3.75 m (12'4")
H120 S	✓	✓	✓	✓
H130 S	✓	✓	✓	✓

Tilt-Rotator TRS23 with S80 Dedicated Coupler

Undercarriage	L		L with Blade (up)	
Counterweight	7.7 mt		5.0 mt	
Boom Type	Reach		Reach	
Stick Length	3.20 m (10'6")	3.75 m (12'4")	3.20 m (10'6")	3.75 m (12'4")
H120 S	✓	✓	✓	✓
H130 S	✓	✓	✓	✓

S80 – TRS23 – S80

Undercarriage	L	L with Blade (up)
Counterweight	7.7 mt	5.0 mt
Boom Type	Reach	Reach
Stick Length	2.50 m (8'2")	2.50 m (8'2")
H120 S	✓	✓
H130 S	✓	✓

HCS70 – TRS23 – HCS70

Undercarriage	L		L with Blade (up)	
Counterweight	7.7 mt		5.0 mt	
Boom Type	Reach		Reach	
Stick Length	3.20 m (10'6")	3.75 m (12'4")	3.20 m (10'6")	3.75 m (12'4")
H120 S	✓	✓	✓	✓
H130 S	✓	✓	✓	✓

HCS70-55 – TRS23 – HCS70-55

Undercarriage	L		L with Blade (up)	
Counterweight	7.7 mt		5.0 mt	
Boom Type	Reach		Reach	
Stick Length	3.20 m (10'6")	3.75 m (12'4")	3.20 m (10'6")	3.75 m (12'4")
H120 S	✓	✓	✓	✓
H130 S	✓	✓	✓	✓

HCS80 – TRS23 – HCS80

Undercarriage	L		L with Blade (up)
Counterweight	7.7 mt		5.0 mt
Boom Type	Reach		Reach
Stick Length	3.20 m (10'6")	3.75 m (12'4")	3.20 m (10'6")
H120 S	✓	✓	✓
H130 S	✓	✓	✓

(continued on next page)

Matching – Tracked Excavators *(continued)*

Match
 * Working Range Front Only
 † Allowed Usage on Machine Less Than 50%
 No Match

336D2 GC

Pin-on

Undercarriage	—
Counterweight	—
Boom Type	Reach
Stick Length	2.80 m (9'2")
H140 S	✓
H160 S	✓

Cat Pin Grabber Coupler

Undercarriage	—
Counterweight	—
Boom Type	Reach
Stick Length	2.80 m (9'2")
H140 S	✓

CW-45 S Dedicated Coupler

Undercarriage	—
Counterweight	—
Boom Type	Reach
Stick Length	2.80 m (9'2")
H140 S	✓

CW-45 Dedicated Coupler

Undercarriage	—
Counterweight	—
Boom Type	Reach
Stick Length	2.80 m (9'2")
H140 S	✓

336D2

Pin-on

Undercarriage	L					
Counterweight	—					
Boom Type	Reach HD				ME	
Stick Length	2.80 m HD (9'2")	3.20 m HD (10'6")	3.20 m (10'6")	3.90 m (12'10")	2.15 m (7'1")	2.55 m (8'4")
H140 S	✓	✓	✓	✓	✓	✓
H160 S	✓	✓	✓	✓	✓	✓

Cat Pin Grabber Coupler

Undercarriage	L					
Counterweight	—					
Boom Type	Reach HD				ME	
Stick Length	2.80 m HD (9'2")	3.20 m HD (10'6")	3.20 m (10'6")	3.90 m (12'10")	2.15 m (7'1")	2.55 m (8'4")
H140 S	✓	✓	✓	✓	✓	✓
H160 S	✓	✓*	✓*		✓	✓*

(continued on next page)

Hammer Technical Specifications

Matching – Tracked Excavators (continued)

Match
 Working Range Front Only
 Allowed Usage on Machine Less Than 50%
 No Match

336D2 (continued)

CW-45 S Dedicated Coupler

Undercarriage	L			
Counterweight	—			
Boom Type	Reach HD		ME	
Stick Length	3.20 m HD (10'6")	3.90 m (12'10")	2.15 m (7'1")	2.55 m (8'4")
H140 S	✓	✓	✓	✓
H160 S	✓*		✓	✓

CW-45 Dedicated Coupler

Undercarriage	L				
Counterweight	—				
Boom Type	Reach HD			ME	
Stick Length	3.20 m HD (10'6")	3.20 m (10'6")	3.90 m (12'10")	2.15 m (7'1")	2.55 m (8'4")
H140 S	✓	✓	✓	✓	✓
H160 S	✓*	✓		✓	✓

336D2 XE

Pin-on

Undercarriage	—		L					
Counterweight	—		—					
Boom Type	Reach HD			Reach HD			ME	
Stick Length	2.80 m HD (9'2")	3.20 m HD (10'6")	2.80 m HD (9'2")	3.20 m HD (10'6")	3.20 m (10'6")	3.90 m (12'10")	2.15 m (7'1")	2.55 m (8'4")
H140 S			✓	✓	✓	✓	✓	✓
H160 S			✓	✓	✓	✓	✓	✓

Cat Pin Grabber Coupler

Undercarriage	—		L				
Counterweight	—		—				
Boom Type	Reach HD		Reach HD	ME			
Stick Length	2.80 m HD (9'2")	3.20 m HD (10'6")	3.20 m (10'6")	2.15 m (7'1")	2.55 m (8'4")		
H140 S			✓	✓	✓		
H160 S			✓*	✓	✓*		

CW-45 Dedicated Coupler

Undercarriage	L		
Counterweight	—		
Boom Type	Reach HD	ME	
Stick Length	3.20 m (10'6")	2.15 m (7'1")	2.55 m (8'4")
H140 S	✓	✓	✓
H160 S	✓	✓	✓

336F

Pin-on

Undercarriage	L			
Counterweight	6.0 mt			
Boom Type	Reach HD			ME
Stick Length	2.80 m HD (9'2")	3.20 m HD (10'6")	3.90 m HD (12'10")	2.55 m (8'4")
H140 S	✓	✓	✓	✓
H160 S	✓	✓	✓	✓

(continued on next page)

Matching – Tracked Excavators (continued)

Match
 Working Range Front Only
 Allowed Usage on Machine Less Than 50%
 No Match

336F (continued)

Pin-on (continued)

Undercarriage	L							
Counterweight	7.0 mt						8.45 mt	
Boom Type	Reach ES		Reach HD			ME	Straight	
Stick Length	3.20 m ES (10'6")	3.90 m ES (12'10")	2.80 m HD (9'2")	3.20 m HD (10'6")	3.90 m HD (12'10")	2.55 m (8'4")	3.20 m HD (10'6")	3.90 m HD (12'10")
H140 S	✓	✓	✓	✓	✓	✓	✓	✓
H160 S	✓	✓	✓	✓	✓	✓	✓	✓

Pin-on (continued)

Undercarriage	LN					
Counterweight	7.0 mt				8.45 mt	
Boom Type	Reach HD			ME	Straight	
Stick Length	2.80 m HD (9'2")	3.20 m HD (10'6")	3.90 m HD (12'10")	2.55 m (8'4")	3.20 m HD (10'6")	3.90 m HD (12'10")
H140 S	✓	✓	✓	✓	✓	✓
H160 S	✓	✓	✓	✓	✓	✓

Cat Pin Grabber Coupler

Undercarriage	L			
Counterweight	6.0 mt			
Boom Type	Reach HD			ME
Stick Length	2.80 m HD (9'2")	3.20 m HD (10'6")	3.90 m HD (12'10")	2.55 m (8'4")
H140 S	✓	✓	✓	✓
H160 S	✓	✓	✓*	✓

Cat Pin Grabber Coupler (continued)

Undercarriage	L							
Counterweight	7.0 mt						8.45 mt	
Boom Type	Reach ES		Reach HD			ME	Straight	
Stick Length	3.20 m ES (10'6")	3.90 m ES (12'10")	2.80 m HD (9'2")	3.20 m HD (10'6")	3.90 m HD (12'10")	2.55 m (8'4")	3.20 m HD (10'6")	3.90 m HD (12'10")
H140 S	✓	✓	✓	✓	✓	✓	✓	✓
H160 S	✓	✓	✓	✓	✓	✓		

Cat Pin Grabber Coupler (continued)

Undercarriage	LN					
Counterweight	7.0 mt				8.45 mt	
Boom Type	Reach HD			ME	Straight	
Stick Length	2.80 m HD (9'2")	3.20 m HD (10'6")	3.90 m HD (12'10")	2.55 m (8'4")	3.20 m HD (10'6")	3.90 m HD (12'10")
H140 S	✓	✓	✓	✓	✓	✓
H160 S	✓	✓	✓*	✓		

(continued on next page)

Hammer Technical Specifications

Matching – Tracked Excavators (continued)

Match
 * Working Range Front Only
 † Allowed Usage on Machine Less Than 50%
 No Match

336F (continued)

CW-45 S Dedicated Coupler

Undercarriage	L					
Counterweight	7.0 mt			8.45 mt		
Boom Type	Reach HD			ME	Straight	
Stick Length	2.80 m HD (9'2")	3.20 m HD (10'6")	3.90 m HD (12'10")	2.55 m (8'4")	3.20 m HD (10'6")	3.90 m HD (12'10")
H140 S	✓	✓	✓	✓	✓	✓
H160 S	✓	✓	✓	✓		

CW-45 S Dedicated Coupler (continued)

Undercarriage	LN					
Counterweight	7.0 mt			8.45 mt		
Boom Type	Reach HD			ME	Straight	
Stick Length	2.80 m HD (9'2")	3.20 m HD (10'6")	3.90 m HD (12'10")	2.55 m (8'4")	3.20 m HD (10'6")	3.90 m HD (12'10")
H140 S	✓	✓	✓	✓	✓	✓
H160 S	✓	✓	✓*	✓		

CW-45 Dedicated Coupler

Undercarriage	L					
Counterweight	7.0 mt			8.45 mt		
Boom Type	Reach HD			ME	Straight	
Stick Length	2.80 m HD (9'2")	3.20 m HD (10'6")	3.90 m HD (12'10")	2.55 m (8'4")	3.20 m HD (10'6")	3.90 m HD (12'10")
H140 S	✓	✓	✓	✓	✓	✓
H160 S	✓	✓	✓	✓		

CW-45 Dedicated Coupler (continued)

Undercarriage	LN					
Counterweight	7.0 mt			8.45 mt		
Boom Type	Reach HD			ME	Straight	
Stick Length	2.80 m HD (9'2")	3.20 m HD (10'6")	3.90 m HD (12'10")	2.55 m (8'4")	3.20 m HD (10'6")	3.90 m HD (12'10")
H140 S	✓	✓	✓	✓	✓	✓
H160 S	✓	✓	✓*	✓		

336F XE

Pin-on

Undercarriage	L			
Counterweight	5.05 mt			
Boom Type	Reach HD			
Stick Length	2.55 m (8'4")	2.80 m HD (9'2")	3.20 m HD (10'6")	3.90 m HD (12'10")
H140 S	✓	✓	✓	✓
H160 S	✓	✓	✓	✓

(continued on next page)

Matching – Tracked Excavators *(continued)*

Match
 Working Range Front Only
 Allowed Usage on Machine Less Than 50%
 No Match

336F XE *(continued)*

Pin-on *(continued)*

Undercarriage	L					
Counterweight	6.05 mt					
Boom Type	Reach ES		Reach HD			ME
Stick Length	3.20 m ES (10'6")	3.90 m ES (12'10")	2.80 m HD (9'2")	3.20 m HD (10'6")	3.90 m HD (12'10")	2.55 m (8'4")
H140 S	✓	✓	✓	✓	✓	✓
H160 S	✓	✓	✓	✓	✓	✓

Pin-on *(continued)*

Undercarriage	LN			
Counterweight	6.05 mt			
Boom Type	Reach HD			ME
Stick Length	2.80 m HD (9'2")	3.20 m HD (10'6")	3.90 m HD (12'10")	2.55 m (8'4")
H140 S	✓	✓	✓	✓
H160 S	✓	✓	✓	✓

Cat Pin Grabber Coupler

Undercarriage	L			
Counterweight	5.05 mt			
Boom Type	Reach HD			
Stick Length	2.55 m (8'4")	2.80 m HD (9'2")	3.20 m HD (10'6")	3.90 m HD (12'10")
H140 S	✓	✓	✓	✓
H160 S	✓	✓	✓	✓*

Cat Pin Grabber Coupler *(continued)*

Undercarriage	L					
Counterweight	6.05 mt					
Boom Type	Reach ES		Reach HD			ME
Stick Length	3.20 m ES (10'6")	3.90 m ES (12'10")	2.80 m HD (9'2")	3.20 m HD (10'6")	3.90 m HD (12'10")	2.55 m (8'4")
H140 S	✓	✓	✓	✓	✓	✓
H160 S	✓	✓	✓	✓	✓	✓

Cat Pin Grabber Coupler *(continued)*

Undercarriage	LN			
Counterweight	6.05 mt			
Boom Type	Reach HD			ME
Stick Length	2.80 m HD (9'2")	3.20 m HD (10'6")	3.90 m HD (12'10")	2.55 m (8'4")
H140 S	✓	✓	✓	✓
H160 S	✓	✓	✓*	✓

(continued on next page)

Hammer Technical Specifications

Matching – Tracked Excavators (continued)

Match
 Working Range Front Only
 Allowed Usage on Machine Less Than 50%
 No Match

336F XE (continued)

CW-45 S Dedicated Coupler

Undercarriage	L				LN			
Counterweight	6.05 mt				6.05 mt			
Boom Type	Reach HD			ME	Reach HD			ME
Stick Length	2.80 m HD (9'2")	3.20 m HD (10'6")	3.90 m HD (12'10")	2.55 m (8'4")	2.80 m HD (9'2")	3.20 m HD (10'6")	3.90 m HD (12'10")	2.55 m (8'4")
H140 S	✓	✓	✓	✓	✓	✓	✓	✓
H160 S	✓	✓	✓	✓	✓	✓	✓*	✓

CW-45 Dedicated Coupler

Undercarriage	L				LN			
Counterweight	6.05 mt				6.05 mt			
Boom Type	Reach HD			ME	Reach HD			ME
Stick Length	2.80 m HD (9'2")	3.20 m HD (10'6")	3.90 m HD (12'10")	2.55 m (8'4")	2.80 m HD (9'2")	3.20 m HD (10'6")	3.90 m HD (12'10")	2.55 m (8'4")
H140 S	✓	✓	✓	✓	✓	✓	✓	✓
H160 S	✓	✓	✓	✓	✓	✓	✓*	✓

336 GC

Pin-on

Undercarriage	—				L			LN	
Counterweight	6.8 mt				6.8 mt			6.8 mt	
Boom Type	Reach				Reach			Reach	
Stick Length	2.80 m (9'2")	3.20 m (10'6")	3.90 m (12'10")	2.80 m (9'2")	3.20 m (10'6")	3.90 m (12'10")	2.80 m (9'2")	3.20 m (10'6")	
H140 S	✓	✓	✓	✓	✓	✓	✓	✓	
H160 S	✓	✓	✓	✓	✓	✓	✓	✓	

Cat Pin Grabber Coupler

Undercarriage	—				L			LN	
Counterweight	6.8 mt				6.8 mt			6.8 mt	
Boom Type	Reach				Reach			Reach	
Stick Length	2.80 m (9'2")	3.20 m (10'6")	3.90 m (12'10")	2.80 m (9'2")	3.20 m (10'6")	3.90 m (12'10")	2.80 m (9'2")	3.20 m (10'6")	
H140 S	✓	✓	✓	✓	✓	✓	✓	✓	
H160 S	✓	✓	✓	✓	✓	✓	✓	✓*	

CW-45 S Dedicated Coupler

Undercarriage	—		L		LN	
Counterweight	6.8 mt		6.8 mt		6.8 mt	
Boom Type	Reach		Reach		Reach	
Stick Length	2.80 m (9'2")	3.20 m (10'6")	2.80 m (9'2")	3.20 m (10'6")	2.80 m (9'2")	3.20 m (10'6")
H140 S	✓	✓	✓	✓	✓	✓
H160 S	✓	✓	✓	✓	✓	✓*

CW-45 Dedicated Coupler

Undercarriage	—		L		LN	
Counterweight	6.8 mt		6.8 mt		6.8 mt	
Boom Type	Reach		Reach		Reach	
Stick Length	2.80 m (9'2")	3.20 m (10'6")	2.80 m (9'2")	3.20 m (10'6")	2.80 m (9'2")	3.20 m (10'6")
H140 S	✓	✓	✓	✓	✓	✓
H160 S	✓	✓	✓	✓	✓	✓*

(continued on next page)

Matching – Tracked Excavators (continued)

Match
 Working Range Front Only
 Allowed Usage on Machine Less Than 50%
 No Match

336

Pin-on

Undercarriage	L					
Counterweight	6.8 mt					
Boom Type	Reach			Reach HD		ME
Stick Length	2.80 m (9'2")	3.20 m (10'6")	3.90 m (12'10")	2.80 m HD (9'2")	3.20 m HD (10'6")	2.55 m (8'4")
H140 S	✓	✓	✓	✓	✓	✓
H160 S	✓	✓	✓	✓	✓	✓

Pin-on (continued)

Undercarriage	L						
Counterweight	7.5 mt						
Boom Type	Reach			Reach HD			ME
Stick Length	2.80 m (9'2")	3.20 m (10'6")	3.90 m (12'10")	2.80 m HD (9'2")	3.20 m HD (10'6")	3.90 m HD (12'10")	2.55 m (8'4")
H140 S	✓	✓	✓		✓	✓	✓
H160 S	✓	✓	✓		✓	✓	✓

Pin-on (continued)

Undercarriage	LN					
Counterweight	7.5 mt					
Boom Type	Reach			Reach HD		ME
Stick Length	2.80 m (9'2")	3.20 m (10'6")	3.90 m (12'10")	3.20 m HD (10'6")	3.90 m HD (12'10")	2.55 m (8'4")
H140 S	✓	✓	✓	✓	✓	✓
H160 S	✓	✓	✓	✓	✓	✓

Cat Pin Grabber Coupler

Undercarriage	L					
Counterweight	6.8 mt					
Boom Type	Reach			Reach HD		ME
Stick Length	2.80 m (9'2")	3.20 m (10'6")	3.90 m (12'10")	2.80 m HD (9'2")	3.20 m HD (10'6")	2.55 m (8'4")
H140 S	✓	✓	✓	✓	✓	✓
H160 S	✓	✓	✓*	✓	✓	✓

Cat Pin Grabber Coupler (continued)

Undercarriage	L						
Counterweight	7.5 mt						
Boom Type	Reach			Reach HD			ME
Stick Length	2.80 m (9'2")	3.20 m (10'6")	3.90 m (12'10")	2.80 m HD (9'2")	3.20 m HD (10'6")	3.90 m HD (12'10")	2.55 m (8'4")
H140 S	✓	✓	✓		✓	✓	✓
H160 S	✓	✓	✓		✓	✓	✓

Cat Pin Grabber Coupler (continued)

Undercarriage	LN					
Counterweight	7.5 mt					
Boom Type	Reach			Reach HD		ME
Stick Length	2.80 m (9'2")	3.20 m (10'6")	3.90 m (12'10")	3.20 m HD (10'6")	3.90 m HD (12'10")	2.55 m (8'4")
H140 S	✓	✓	✓	✓	✓	✓
H160 S	✓	✓	✓*	✓		✓

(continued on next page)

Hammer Technical Specifications

Matching – Tracked Excavators (continued)

Match
 Working Range Front Only
 Allowed Usage on Machine Less Than 50%
 No Match

336 (continued)

CW-45 S Dedicated Coupler

Undercarriage	L						
Counterweight	6.8 mt			7.5 mt			
Boom Type	Reach HD	ME	Reach			Reach HD	ME
Stick Length	3.20 m HD (10'6")	2.55 m (8'4")	2.80 m (9'2")	3.20 m (10'6")	3.90 m (12'10")	3.20 m HD (10'6")	2.55 m (8'4")
H140 S	✓	✓	✓	✓	✓	✓	✓
H160 S	✓	✓	✓	✓	✓	✓	✓

CW-45 S Dedicated Coupler (continued)

Undercarriage	LN					
Counterweight	7.5 mt					
Boom Type	Reach			Reach HD		ME
Stick Length	2.80 m (9'2")	3.20 m (10'6")	3.90 m (12'10")	3.20 m HD (10'6")	3.90 m HD (12'10")	2.55 m (8'4")
H140 S	✓	✓	✓	✓	✓	✓
H160 S	✓	✓	✓*	✓		✓

CW-45 Dedicated Coupler

Undercarriage	L							
Counterweight	6.8 mt				7.5 mt			
Boom Type	Reach HD		ME	Reach			Reach HD	ME
Stick Length	2.80 m HD (9'2")	3.20 m HD (10'6")	2.55 m (8'4")	2.80 m (9'2")	3.20 m (10'6")	3.90 m (12'10")	3.20 m HD (10'6")	2.55 m (8'4")
H140 S	✓	✓	✓	✓	✓	✓	✓	✓
H160 S	✓	✓	✓	✓	✓	✓	✓	✓

CW-45 Dedicated Coupler (continued)

Undercarriage	LN					
Counterweight	7.5 mt					
Boom Type	Reach			Reach HD		ME
Stick Length	2.80 m (9'2")	3.20 m (10'6")	3.90 m (12'10")	3.20 m HD (10'6")	3.90 m HD (12'10")	2.55 m (8'4")
H140 S	✓	✓	✓	✓	✓	✓
H160 S	✓	✓	✓*	✓		✓

340D2

Pin-on

Undercarriage	L							
Counterweight	—				8.5 mt			
Boom Type	Reach HD		ME		Reach HD		ME	
Stick Length	2.80 m HD (9'2")	3.20 m HD (10'6")	2.15 m (7'1")	2.55 m (8'4")	2.80 m HD (9'2")	3.20 m HD (10'6")	2.15 m (7'1")	2.55 m (8'4")
H140 S		✓	✓	✓	✓	✓	✓	✓
H160 S		✓	✓	✓	✓	✓	✓	✓
H180 S		✓	✓	✓	✓	✓	✓	✓

(continued on next page)

Matching – Tracked Excavators (continued)

Match
 * Working Range Front Only
 † Allowed Usage on Machine Less Than 50%
 No Match

340D2 (continued)

Cat Pin Grabber Coupler

Undercarriage	L						
Counterweight	—			8.5 mt			
Boom Type	Reach HD		ME		Reach HD	ME	
Stick Length	2.80 m HD (9'2")	3.20 m HD (10'6")	2.15 m (7'1")	2.55 m (8'4")	3.20 m HD (10'6")	2.15 m (7'1")	2.55 m (8'4")
H140 S		✓	✓	✓	✓	✓	✓
H160 S		✓	✓	✓	✓	✓	✓
H180 S		✓*	✓	✓	✓	✓	✓

CW-45 S Dedicated Coupler

Undercarriage	L					
Counterweight	—			8.5 mt		
Boom Type	Reach HD	ME		Reach HD	ME	
Stick Length	3.20 m HD (10'6")	2.15 m (7'1")	2.55 m (8'4")	3.20 m HD (10'6")	2.15 m (7'1")	2.55 m (8'4")
H140 S	✓	✓	✓	✓	✓	✓
H160 S	✓	✓	✓	✓	✓	✓
H180 S	✓	✓	✓	✓	✓	✓

CW-45 Dedicated Coupler

Undercarriage	L					
Counterweight	—			8.5 mt		
Boom Type	Reach HD	ME		Reach HD	ME	
Stick Length	3.20 m HD (10'6")	2.15 m (7'1")	2.55 m (8'4")	3.20 m HD (10'6")	2.15 m (7'1")	2.55 m (8'4")
H140 S	✓	✓	✓	✓	✓	✓
H160 S	✓	✓	✓	✓	✓	✓
H180 S	✓	✓	✓	✓	✓	✓

340F

Pin-on

Undercarriage	L		
Counterweight	7.0 mt		
Boom Type	Reach HD		ME
Stick Length	2.80 m HD (9'2")	3.20 m HD (10'6")	2.55 m (8'4")
H140 S	✓	✓	✓
H160 S	✓	✓	✓
H180 S	✓†	✓†	✓†

Cat Pin Grabber Coupler

Undercarriage	L		
Counterweight	7.0 mt		
Boom Type	Reach HD		ME
Stick Length	2.80 m HD (9'2")	3.20 m HD (10'6")	2.55 m (8'4")
H140 S	✓	✓	✓
H160 S	✓	✓	✓

(continued on next page)

Hammer Technical Specifications

Matching – Tracked Excavators *(continued)*

Match
 * Working Range Front Only
 † Allowed Usage on Machine Less Than 50%
 No Match

340F *(continued)*

CW-45 S Dedicated Coupler

Undercarriage	L		
Counterweight	7.0 mt		
Boom Type	Reach HD		ME
Stick Length	2.80 m HD (9'2")	3.20 m HD (10'6")	2.55 m (8'4")
H140 S	✓	✓	✓
H160 S	✓	✓	✓

CW-45 Dedicated Coupler

Undercarriage	L		
Counterweight	7.0 mt		
Boom Type	Reach HD		ME
Stick Length	2.80 m HD (9'2")	3.20 m HD (10'6")	2.55 m (8'4")
H140 S	✓	✓	✓
H160 S	✓	✓	✓

340F UHD

Pin-on

Undercarriage	L-FIX					
Counterweight	8.45 mt					
Boom Type	Retrofit (B)			Retrofit (S)		
Stick Length	2.80 m HD (9'2")	3.20 m HD (10'6")	3.90 m HD (12'10")	2.80 m HD (9'2")	3.20 m HD (10'6")	3.90 m HD (12'10")
H140 S	✓	✓	✓	✓	✓	✓
H160 S	✓	✓	✓	✓	✓	✓
H180 S	✓†	✓†	✓†			

Pin-on *(continued)*

Undercarriage	L-VG					
Counterweight	8.45 mt					
Boom Type	Retrofit (B)			Retrofit (S)		
Stick Length	2.80 m HD (9'2")	3.20 m HD (10'6")	3.90 m HD (12'10")	2.80 m HD (9'2")	3.20 m HD (10'6")	3.90 m HD (12'10")
H140 S	✓	✓	✓	✓	✓	✓
H160 S	✓	✓	✓	✓	✓	✓
H180 S	✓†	✓†	✓†			

Cat Pin Grabber Coupler

Undercarriage	L-FIX					
Counterweight	8.45 mt					
Boom Type	Retrofit (B)			Retrofit (S)		
Stick Length	2.80 m HD (9'2")	3.20 m HD (10'6")	3.90 m HD (12'10")	2.80 m HD (9'2")	3.20 m HD (10'6")	3.90 m HD (12'10")
H140 S	✓	✓	✓	✓	✓	✓
H160 S	✓	✓	✓			

(continued on next page)

Matching – Tracked Excavators *(continued)*

Match
 * Working Range Front Only
 † Allowed Usage on Machine Less Than 50%
 No Match

340F UHD *(continued)*

Cat Pin Grabber Coupler *(continued)*

Undercarriage	L-VG					
Counterweight	8.45 mt					
Boom Type	Retrofit (B)			Retrofit (S)		
Stick Length	2.80 m HD (9'2")	3.20 m HD (10'6")	3.90 m HD (12'10")	2.80 m HD (9'2")	3.20 m HD (10'6")	3.90 m HD (12'10")
H140 S	✓	✓	✓	✓	✓	✓
H160 S	✓	✓	✓			

CW-45 S Dedicated Coupler

Undercarriage	L-FIX					
Counterweight	8.45 mt					
Boom Type	Retrofit (B)			Retrofit (S)		
Stick Length	2.80 m HD (9'2")	3.20 m HD (10'6")	3.90 m HD (12'10")	2.80 m HD (9'2")	3.20 m HD (10'6")	3.90 m HD (12'10")
H130 S	✓	✓	✓	✓	✓	✓
H140 S	✓	✓	✓	✓	✓	✓
H160 S	✓	✓	✓			
H180 S	✓	✓				

CW-45 S Dedicated Coupler *(continued)*

Undercarriage	L-VG					
Counterweight	8.45 mt					
Boom Type	Retrofit (B)			Retrofit (S)		
Stick Length	2.80 m HD (9'2")	3.20 m HD (10'6")	3.90 m HD (12'10")	2.80 m HD (9'2")	3.20 m HD (10'6")	3.90 m HD (12'10")
H130 S	✓	✓	✓	✓	✓	✓
H140 S	✓	✓	✓	✓	✓	✓
H160 S	✓	✓	✓			
H180 S	✓	✓				

CW-45 Dedicated Coupler

Undercarriage	L-FIX					
Counterweight	8.45 mt					
Boom Type	Retrofit (B)			Retrofit (S)		
Stick Length	2.80 m HD (9'2")	3.20 m HD (10'6")	3.90 m HD (12'10")	2.80 m HD (9'2")	3.20 m HD (10'6")	3.90 m HD (12'10")
H140 S	✓	✓	✓	✓	✓	✓
H160 S	✓	✓	✓			

CW-45 Dedicated Coupler *(continued)*

Undercarriage	L-VG					
Counterweight	8.45 mt					
Boom Type	Retrofit (B)			Retrofit (S)		
Stick Length	2.80 m HD (9'2")	3.20 m HD (10'6")	3.90 m HD (12'10")	2.80 m HD (9'2")	3.20 m HD (10'6")	3.90 m HD (12'10")
H140 S	✓	✓	✓	✓	✓	✓
H160 S	✓	✓	✓			

(continued on next page)

Hammer Technical Specifications

Matching – Tracked Excavators (continued)

Match
 Working Range Front Only
 Allowed Usage on Machine Less Than 50%
 No Match

340

Pin-on

Undercarriage	L		LN		HD High Wide			
Counterweight	9.0 mt		9.0 mt		7.5 mt			
Boom Type	Straight		Straight		Reach			ME
Stick Length	3.20 m (10'6")	3.90 m (12'10")	3.20 m (10'6")	3.90 m (12'10")	2.80 m (9'2")	3.20 m (10'6")	3.90 m (12'10")	2.55 m (8'4")
H140 S	✓	✓	✓	✓	✓	✓	✓	✓
H160 S	✓	✓	✓	✓	✓	✓	✓	✓

Cat Pin Grabber Coupler

Undercarriage	L		LN		HD High Wide			
Counterweight	9.0 mt		9.0 mt		7.5 mt			
Boom Type	Straight		Straight		Reach			ME
Stick Length	3.20 m (10'6")	3.90 m (12'10")	3.20 m (10'6")	3.90 m (12'10")	2.80 m (9'2")	3.20 m (10'6")	3.90 m (12'10")	2.55 m (8'4")
H140 S	✓	✓	✓	✓	✓	✓	✓	✓
H160 S					✓	✓	✓	✓

CW-45 S Dedicated Coupler

Undercarriage	L		LN		HD High Wide			
Counterweight	9.0 mt		9.0 mt		7.5 mt			
Boom Type	Straight		Straight		Reach			ME
Stick Length	3.20 m (10'6")	3.90 m (12'10")	3.20 m (10'6")	3.90 m (12'10")	2.80 m (9'2")	3.20 m (10'6")	3.90 m (12'10")	2.55 m (8'4")
H140 S	✓	✓	✓	✓	✓	✓	✓	✓
H160 S					✓	✓	✓	✓

CW-45 Dedicated Coupler

Undercarriage	L		LN		HD High Wide			
Counterweight	9.0 mt		9.0 mt		7.5 mt			
Boom Type	Straight		Straight		Reach			ME
Stick Length	3.20 m (10'6")	3.90 m (12'10")	3.20 m (10'6")	3.90 m (12'10")	2.80 m (9'2")	3.20 m (10'6")	3.90 m (12'10")	2.55 m (8'4")
H140 S	✓	✓	✓	✓	✓	✓	✓	✓
H160 S					✓	✓	✓	✓

340 UHD

Pin-on

Undercarriage	L					
Counterweight	9.0 mt					
Boom Type	Retrofit (B)			Retrofit (S)		
Stick Length	2.80 m (9'2")	3.20 m (10'6")	3.90 m (12'10")	2.80 m (9'2")	3.20 m (10'6")	3.90 m (12'10")
H140 S	✓	✓	✓	✓	✓	✓
H160 S	✓	✓	✓	✓	✓	✓
H180 S	✓	✓	✓	✓	✓*	

(continued on next page)

Matching – Tracked Excavators *(continued)*

Match
 Working Range Front Only
 † Allowed Usage on Machine Less Than 50%
 No Match

340 UHD *(continued)*

Pin-on *(continued)*

Undercarriage	H-VG					
Counterweight	9.0 mt					
Boom Type	Retrofit (B)			Retrofit (S)		
Stick Length	2.80 m (9'2")	3.20 m (10'6")	3.90 m (12'10")	2.80 m (9'2")	3.20 m (10'6")	3.90 m (12'10")
H140 S	✓	✓	✓	✓	✓	✓
H160 S	✓	✓	✓	✓	✓	✓
H180 S	✓	✓	✓	✓	✓	✓

Cat Pin Grabber Coupler

Undercarriage	L					
Counterweight	9.0 mt					
Boom Type	Retrofit (B)			Retrofit (S)		
Stick Length	2.80 m (9'2")	3.20 m (10'6")	3.90 m (12'10")	2.80 m (9'2")	3.20 m (10'6")	3.90 m (12'10")
H140 S	✓	✓	✓	✓	✓	✓
H160 S	✓	✓	✓			
H180 S	✓†	✓†*				

Cat Pin Grabber Coupler *(continued)*

Undercarriage	H-VG					
Counterweight	9.0 mt					
Boom Type	Retrofit (B)			Retrofit (S)		
Stick Length	2.80 m (9'2")	3.20 m (10'6")	3.90 m (12'10")	2.80 m (9'2")	3.20 m (10'6")	3.90 m (12'10")
H140 S	✓	✓	✓	✓	✓	✓
H160 S	✓	✓	✓			
H180 S	✓†	✓†			✓†	

CW-45 Dedicated Coupler

Undercarriage	L					
Counterweight	9.0 mt					
Boom Type	Retrofit (B)			Retrofit (S)		
Stick Length	2.80 m (9'2")	3.20 m (10'6")	3.90 m (12'10")	2.80 m (9'2")	3.20 m (10'6")	3.90 m (12'10")
H140 S	✓	✓	✓	✓	✓	✓
H160 S	✓	✓	✓			
H180 S	✓	✓				

CW-45 Dedicated Coupler *(continued)*

Undercarriage	H-VG					
Counterweight	9.0 mt					
Boom Type	Retrofit (B)			Retrofit (S)		
Stick Length	2.80 m (9'2")	3.20 m (10'6")	3.90 m (12'10")	2.80 m (9'2")	3.20 m (10'6")	3.90 m (12'10")
H140 S	✓	✓	✓	✓	✓	✓
H160 S	✓	✓	✓			
H180 S	✓	✓				

(continued on next page)

Hammer Technical Specifications

Matching – Tracked Excavators *(continued)*

Match
 Working Range Front Only
 Allowed Usage on Machine Less Than 50%
 No Match

340 UHD *(continued)*

S80 Dedicated Coupler

Undercarriage	L					
Counterweight	9.0 mt					
Boom Type	Retrofit (B)			Retrofit (S)		
Stick Length	2.80 m (9'2")	3.20 m (10'6")	3.90 m (12'10")	2.80 m (9'2")	3.20 m (10'6")	3.90 m (12'10")
H140 S	✓	✓	✓	✓	✓	✓
H160 S	✓	✓	✓	✓	✓	
H180 S	✓	✓				

S80 Dedicated Coupler *(continued)*

Undercarriage	H-VG					
Counterweight	9.0 mt					
Boom Type	Retrofit (B)			Retrofit (S)		
Stick Length	2.80 m (9'2")	3.20 m (10'6")	3.90 m (12'10")	2.80 m (9'2")	3.20 m (10'6")	3.90 m (12'10")
H140 S	✓	✓	✓	✓	✓	✓
H160 S	✓	✓	✓	✓	✓	✓
H180 S	✓	✓				

HCS80 Dedicated Coupler

Undercarriage	L					
Counterweight	9.0 mt					
Boom Type	Retrofit (B)			Retrofit (S)		
Stick Length	2.80 m (9'2")	3.20 m (10'6")	3.90 m (12'10")	2.80 m (9'2")	3.20 m (10'6")	3.90 m (12'10")
H140 S	✓	✓	✓	✓	✓	✓
H160 S	✓	✓	✓	✓	✓	

HCS80 Dedicated Coupler *(continued)*

Undercarriage	H-VG					
Counterweight	9.0 mt					
Boom Type	Retrofit (B)			Retrofit (S)		
Stick Length	2.80 m (9'2")	3.20 m (10'6")	3.90 m (12'10")	2.80 m (9'2")	3.20 m (10'6")	3.90 m (12'10")
H140 S	✓	✓	✓	✓	✓	✓
H160 S	✓	✓	✓	✓	✓	✓

345 GC

Pin-on

Undercarriage	—			
Counterweight	9.0 mt			
Boom Type	Reach HD		ME	
Stick Length	2.90 m HD (9'6")	3.35 m HD (11'0")	2.50 m (8'2")	3.00 m (9'10")
H160 S	✓	✓	✓	✓
H180 S	✓	✓	✓	✓
H190 S	✓	✓	✓	✓

(continued on next page)

Matching – Tracked Excavators *(continued)*

Match
 Working Range Front Only
 Allowed Usage on Machine Less Than 50%
 No Match

345 GC *(continued)*

Cat Pin Grabber Coupler

Undercarriage	—	
Counterweight	9.0 mt	
Boom Type	Reach HD	
Stick Length	2.90 m HD (9'6")	3.35 m HD (11'0")
H160 S	✓	✓
H180 S	✓	✓*

CW-55 Dedicated Coupler

Undercarriage	—			
Counterweight	9.0 mt			
Boom Type	Reach HD		ME	
Stick Length	2.90 m HD (9'6")	3.35 m HD (11'0")	2.50 m (8'2")	3.00 m (9'10")
H160 S	✓	✓	✓	✓
H180 S	✓	✓*	✓	✓*

349D2

Pin-on

Undercarriage	—				L-FIX			
Counterweight	—				—			
Boom Type	Reach HD		ME		Reach HD		ME	
Stick Length	3.35 m HD (11'0")	3.90 m HD (12'10")	2.50 m (8'2")	3.00 m (9'10")	3.35 m HD (11'0")	3.90 m HD (12'10")	2.50 m (8'2")	3.00 m (9'10")
H160 S	✓	✓	✓	✓	✓	✓	✓	✓
H180 S	✓	✓	✓	✓	✓	✓	✓	✓
H190 S	✓	✓	✓	✓	✓	✓	✓	✓

Cat Pin Grabber Coupler

Undercarriage	—		L-FIX			
Counterweight	—		—			
Boom Type	Reach HD		Reach HD		ME	
Stick Length	3.35 m HD (11'0")	3.90 m HD (12'10")	3.35 m HD (11'0")	3.90 m HD (12'10")	2.50 m (8'2")	
H160 S	✓	✓	✓	✓		
H180 S	✓	✓	✓	✓		
H190 S					✓*	

CW-55 Dedicated Coupler

Undercarriage	—				L-FIX			
Counterweight	—				—			
Boom Type	Reach HD		ME		Reach HD		ME	
Stick Length	3.35 m HD (11'0")	3.90 m HD (12'10")	2.50 m (8'2")	3.00 m (9'10")	3.35 m HD (11'0")	3.90 m HD (12'10")	2.50 m (8'2")	3.00 m (9'10")
H160 S	✓	✓	✓	✓	✓	✓	✓	✓
H180 S	✓	✓	✓	✓	✓	✓	✓	✓
H190 S			✓	✓*			✓	✓*

(continued on next page)

Hammer Technical Specifications

Matching – Tracked Excavators *(continued)*

Match
 Working Range Front Only
 Allowed Usage on Machine Less Than 50%
 No Match

349F

Pin-on

Undercarriage	L-FIX				
Counterweight	—				
Boom Type	Long-Reach	Reach HD		ME	
Stick Length	4.30 m HD (14'1")	3.40 m HD (11'2")	3.90 m HD (12'10")	2.50 m (8'2")	3.00 m (9'10")
H160 S	✓	✓	✓	✓	✓
H180 S	✓	✓	✓	✓	✓
H190 S		✓	✓	✓	✓

Cat Pin Grabber Coupler

Undercarriage	L-FIX			
Counterweight	—			
Boom Type	Long-Reach	Reach HD		ME
Stick Length	4.30 m HD (14'1")	3.40 m HD (11'2")	3.90 m HD (12'10")	2.50 m (8'2")
H160 S	✓	✓	✓	
H180 S		✓	✓	
H190 S				✓

349F XE

Pin-on

Undercarriage	L-FIX				
Counterweight	—				
Boom Type	Long-Reach	Reach HD		ME	
Stick Length	4.30 m HD (14'1")	3.40 m HD (11'2")	3.90 m HD (12'10")	2.50 m (8'2")	3.00 m (9'10")
H160 S	✓	✓	✓	✓	✓
H180 S	✓	✓	✓	✓	✓
H190 S		✓	✓	✓	✓

Cat Pin Grabber Coupler

Undercarriage	L-FIX			
Counterweight	—			
Boom Type	Long-Reach	Reach HD		ME
Stick Length	4.30 m HD (14'1")	3.40 m HD (11'2")	3.90 m HD (12'10")	2.50 m (8'2")
H160 S	✓	✓	✓	
H180 S		✓	✓	
H190 S				✓

(continued on next page)

Matching – Tracked Excavators (continued)

Match
 Working Range Front Only
 Allowed Usage on Machine Less Than 50%
 No Match

349

Pin-on

Undercarriage	L					
Counterweight	9.0 mt					
Boom Type	Long-Reach	Reach HD			ME	
Stick Length	4.30 m HD (14'1")	2.90 m HD (9'6")	3.35 m HD (11'0")	3.90 m HD (12'10")	2.50 m (8'2")	3.00 m (9'10")
H160 S	✓	✓	✓	✓	✓	✓
H180 S	✓	✓	✓	✓	✓	✓
H190 S		✓	✓	✓	✓	✓

Cat Pin Grabber Coupler

Undercarriage	L					
Counterweight	9.0 mt					
Boom Type	Long-Reach	Reach HD			ME	
Stick Length	4.30 m HD (14'1")	2.90 m HD (9'6")	3.35 m HD (11'0")	3.90 m HD (12'10")	2.50 m (8'2")	
H160 S	✓	✓	✓	✓		
H180 S		✓	✓	✓		
H190 S		✓*			✓	

CW-55 Dedicated Coupler

Undercarriage	L				
Counterweight	9.0 mt				
Boom Type	Reach HD		ME		
Stick Length	2.90 m HD (9'6")	3.35 m HD (11'0")	2.50 m (8'2")	3.00 m (9'10")	
H160 S	✓	✓	✓	✓	
H180 S	✓	✓	✓	✓	
H190 S	✓*	✓*	✓	✓*	

352F

Pin-on

Undercarriage	L-VG					
Counterweight	—					
Boom Type	Long-Reach	Reach HD			ME	
Stick Length	4.30 m HD (14'1")	2.90 m HD (9'6")	3.40 m HD (11'2")	3.90 m HD (12'10")	2.50 m (8'2")	3.00 m (9'10")
H160 S	✓	✓	✓	✓	✓	✓
H180 S	✓	✓	✓	✓	✓	✓
H190 S	✓	✓	✓	✓	✓	✓

Cat Pin Grabber Coupler

Undercarriage	L-VG					
Counterweight	—					
Boom Type	Long-Reach	Reach HD			ME	
Stick Length	4.30 m HD (14'1")	2.90 m HD (9'6")	3.40 m HD (11'2")	3.90 m HD (12'10")	2.50 m (8'2")	3.00 m (9'10")
H160 S	✓	✓	✓	✓		
H180 S	✓	✓	✓	✓		
H190 S		✓			✓	✓

(continued on next page)

Hammer Technical Specifications

Matching – Tracked Excavators (continued)

Match
 Working Range Front Only
 Allowed Usage on Machine Less Than 50%
 No Match

352F (continued)

CW-55 Dedicated Coupler

Undercarriage	L-VG			
Counterweight	—			
Boom Type	Reach HD		ME	
Stick Length	2.90 m HD (9'6")	3.40 m HD (11'2")	2.50 m (8'2")	3.00 m (9'10")
H160 S	✓	✓	✓	✓
H180 S	✓	✓	✓	✓
H190 S	✓	✓	✓	✓

352F XE

Pin-on

Undercarriage	L-VG					
Counterweight	—					
Boom Type	Long-Reach	Reach HD			ME	
Stick Length	4.30 m HD (14'1")	2.90 m HD (9'6")	3.40 m HD (11'2")	3.90 m HD (12'10")	2.50 m (8'2")	3.00 m (9'10")
H160 S	✓	✓	✓	✓	✓	✓
H180 S	✓	✓	✓	✓	✓	✓
H190 S	✓	✓	✓	✓	✓	✓

Cat Pin Grabber Coupler

Undercarriage	L-VG					
Counterweight	—					
Boom Type	Long-Reach	Reach HD			ME	
Stick Length	4.30 m HD (14'1")	2.90 m HD (9'6")	3.40 m HD (11'2")	3.90 m HD (12'10")	2.50 m (8'2")	3.00 m (9'10")
H160 S	✓	✓	✓	✓		
H180 S	✓	✓	✓	✓		
H190 S		✓			✓	✓

CW-55 Dedicated Coupler

Undercarriage	L-VG			
Counterweight	—			
Boom Type	Reach HD		ME	
Stick Length	2.90 m HD (9'6")	3.40 m HD (11'2")	2.50 m (8'2")	3.00 m (9'10")
H160 S	✓	✓	✓	✓
H180 S	✓	✓	✓	✓
H190 S	✓	✓	✓	✓

352

Pin-on

Undercarriage	L-VG					
Counterweight	9.0 mt					
Boom Type	Long-Reach	Reach HD			ME	
Stick Length	4.30 m HD (14'1")	2.90 m HD (9'6")	3.35 m HD (11'0")	3.90 m HD (12'10")	2.50 m (8'2")	3.00 m (9'10")
H160 S	✓	✓	✓	✓	✓	✓
H180 S	✓	✓	✓	✓	✓	✓
H190 S	✓	✓	✓	✓	✓	✓

(continued on next page)

Matching – Tracked Excavators (continued)

Match
 Working Range Front Only
 Allowed Usage on Machine Less Than 50%
 No Match

352 (continued)

Pin-on (continued)

Undercarriage	L				
Counterweight	9.8 mt				
Boom Type	Reach			ME	
Stick Length	2.90 m (9'6")	3.35 m (11'0")	3.90 m (12'10")	2.50 m (8'2")	3.00 m (9'10")
H160 S					
H180 S					
H190 S	✓	✓	✓	✓	✓

Pin-on (continued)

Undercarriage	L-VG					
Counterweight	9.8 mt					
Boom Type	Reach			Long-Reach	ME	
Stick Length	2.90 m (9'6")	3.35 m (11'0")	3.90 m (12'10")	4.30 m (14'1")	2.50 m (8'2")	3.00 m (9'10")
H160 S						
H180 S						
H190 S	✓	✓	✓	✓	✓	✓

Cat Pin Grabber Coupler

Undercarriage	L-VG					
Counterweight	9.0 mt					
Boom Type	Long-Reach	Reach HD			ME	
Stick Length	4.30 m HD (14'1")	2.90 m HD (9'6")	3.35 m HD (11'0")	3.90 m HD (12'10")	2.50 m (8'2")	3.00 m (9'10")
H160 S	✓	✓	✓	✓		
H180 S	✓*	✓	✓	✓		
H190 S		✓†			✓	✓

Cat Pin Grabber Coupler (continued)

Undercarriage	L		L-VG		
Counterweight	9.8 mt		9.8 mt		
Boom Type	Reach	ME	Reach	ME	
Stick Length	2.90 m (9'6")	2.50 m (8'2")	2.90 m (9'6")	2.50 m (8'2")	3.00 m (9'10")
H160 S					
H180 S					
H190 S	✓*	✓	✓†	✓	✓

CW-55 Dedicated Coupler

Undercarriage	L-VG					
Counterweight	9.0 mt					
Boom Type	Long-Reach	Reach HD			ME	
Stick Length	4.30 m HD (14'1")	2.90 m HD (9'6")	3.35 m HD (11'0")	2.50 m (8'2")	3.00 m (9'10")	
H160 S	✓	✓	✓	✓	✓	
H180 S	✓	✓	✓	✓	✓	
H190 S		✓	✓	✓	✓	

(continued on next page)

Hammer Technical Specifications

Matching – Tracked Excavators (continued)

Match
 * Working Range Front Only
 † Allowed Usage on Machine Less Than 50%
 No Match

352 (continued)

CW-55 Dedicated Coupler (continued)

Undercarriage	L-VG			
Counterweight	9.8 mt			
Boom Type	Reach		ME	
Stick Length	2.90 m (9'6")	3.35 m (11'0")	2.50 m (8'2")	3.00 m (9'10")
H160 S				
H180 S				
H190 S	✓	✓	✓	✓

352 UHD

Pin-on

Undercarriage	H-VG					
Counterweight	12.0 mt					
Boom Type	Retrofit (B)			Retrofit (S)		
Stick Length	2.90 m HD (9'6")	3.35 m HD (11'0")	3.90 m HD (12'10")	2.90 m HD (9'6")	3.35 m HD (11'0")	3.90 m HD (12'10")
H160 S	✓	✓	✓	✓	✓	✓
H180 S	✓	✓	✓	✓	✓	✓
H190 S	✓	✓	✓	✓	✓	✓

Cat Pin Grabber Coupler

Undercarriage	H-VG					
Counterweight	12.0 mt					
Boom Type	Retrofit (B)			Retrofit (S)		
Stick Length	2.90 m HD (9'6")	3.35 m HD (11'0")	3.90 m HD (12'10")	2.90 m HD (9'6")	3.35 m HD (11'0")	3.90 m HD (12'10")
H160 S	✓	✓	✓	✓	✓	✓
H180 S	✓†	✓†	✓†	✓†	✓†	✓†
H190 S	✓†			✓†		

CW-55 Dedicated Coupler

Undercarriage	H-VG					
Counterweight	12.0 mt					
Boom Type	Retrofit (B)			Retrofit (S)		
Stick Length	2.90 m HD (9'6")	3.35 m HD (11'0")	3.90 m HD (12'10")	2.90 m HD (9'6")	3.35 m HD (11'0")	3.90 m HD (12'10")
H160 S	✓	✓	✓	✓	✓	✓
H180 S	✓	✓	✓	✓	✓	✓
H190 S	✓			✓		

355

Pin-on

Undercarriage	L			L-VG		
Counterweight	9.8 mt			9.8 mt		
Boom Type	ME SD		Reach SD	ME SD		Reach SD
Stick Length	2.50 m SD (8'2")	3.00 m SD (9'10")	2.90 m SD (9'6")	2.50 m SD (8'2")	3.00 m SD (9'10")	2.90 m SD (9'6")
H190 S	✓	✓	✓	✓	✓	✓

(continued on next page)

Hammer Technical Specifications

Matching – Tracked Excavators (continued)

Match
 Working Range Front Only
 Allowed Usage on Machine Less Than 50%
 No Match

374F

Pin-on

Undercarriage	L					
Counterweight	—					
Boom Type	Reach				ME	
Stick Length	2.84 m HD (9'4")	3.60 m HD (11'10")	4.15 m HD (13'7")	4.67 m HD (15'4")	2.57 m (8'5")	3.00 m (9'10")
H160 S	✓	✓	✓	✓	✓	✓
H180 S	✓	✓	✓	✓	✓	✓
H190 S	✓	✓	✓	✓	✓	✓
H215 S	✓	✓	✓	✓	✓	✓

Cat Pin Grabber Coupler

Undercarriage	L			
Counterweight	—			
Boom Type	Reach			
Stick Length	2.84 m HD (9'4")	3.60 m HD (11'10")	4.15 m HD (13'7")	4.67 m HD (15'4")
H190 S	✓	✓	✓	✓
H215 S	✓	✓*		

CW-70 Dedicated Coupler

Undercarriage	L					
Counterweight	—					
Boom Type	Reach				ME	
Stick Length	2.84 m HD (9'4")	3.60 m HD (11'10")	4.15 m HD (13'7")	4.67 m HD (15'4")	2.57 m (8'5")	3.00 m (9'10")
H160 S	✓	✓	✓	✓	✓	✓
H180 S	✓	✓	✓	✓	✓	✓
H190 S	✓	✓	✓	✓	✓	✓
H215 S	✓	✓*			✓	✓

374

Pin-on

Undercarriage	L-VG					
Counterweight	11.2 mt					
Boom Type	Reach HD				ME	
Stick Length	2.84 m HD (9'4")	3.60 m HD (11'10")	4.15 m HD (13'7")	4.67 m HD (15'4")	2.57 m (8'5")	3.00 m (9'10")
H180 S	✓	✓	✓	✓	✓	✓
H190 S	✓	✓	✓	✓	✓	✓
H215 S	✓	✓	✓	✓	✓	✓

(continued on next page)

Hammer Technical Specifications

Matching – Tracked Excavators (continued)

Match
 * Working Range Front Only
 † Allowed Usage on Machine Less Than 50%
 No Match

374 (continued)

Cat Pin Grabber Coupler

Undercarriage	L-VG			
Counterweight	11.2 mt			
Boom Type	Reach HD			
Stick Length	2.84 m HD (9'4")	3.60 m HD (11'10")	4.15 m HD (13'7")	4.67 m HD (15'4")
H180 S	✓	✓	✓	✓
H190 S	✓	✓	✓	✓
H215 S	✓	✓*		

CW-70 Dedicated Coupler

Undercarriage	L-VG					
Counterweight	11.2 mt					
Boom Type	Reach HD				ME	
Stick Length	2.84 m HD (9'4")	3.60 m HD (11'10")	4.15 m HD (13'7")	4.67 m HD (15'4")	2.57 m (8'5")	3.00 m (9'10")
H180 S	✓	✓	✓	✓	✓	✓
H190 S		✓	✓	✓	✓	✓
H215 S		✓*			✓	✓

390F

Pin-on

Undercarriage	L					
Counterweight	—					
Boom Type	GP			Reach	ME	
Stick Length	2.92 m HD (9'6")	3.40 m HD (11'2")	4.40 m HD (14'5")	4.40 m HD (14'5")	2.92 m (9'7")	3.40 m (11'2")
H215 S	✓	✓	✓	✓	✓	✓

CW-70 Dedicated Coupler

Undercarriage	L					
Counterweight	—					
Boom Type	GP			ME		
Stick Length	2.92 m HD (9'6")	3.40 m HD (11'2")	4.40 m HD (14'5")	2.92 m (9'7")	3.40 m (11'2")	
H215 S	✓	✓	✓	✓	✓	

395

Pin-on

Undercarriage	L-VG						
Counterweight	15.7 mt						
Boom Type	GP				Reach	ME	
Stick Length	2.92 m HD (9'6")	3.40 m HD (11'2")	4.40 m HD (14'5")	3.70 m HD (12'0")	4.40 m HD (14'5")	2.92 m (9'7")	3.40 m (11'2")
H215 S	✓	✓	✓	✓	✓	✓	✓

(continued on next page)

Matching – Tracked Excavators *(continued)*

Match
 * Working Range Front Only
 † Allowed Usage on Machine Less Than 50%
 No Match

395 *(continued)*

Cat Pin Grabber Coupler

Undercarriage	L-VG	
Counterweight	15.7 mt	
Boom Type	GP	
Stick Length	3.70 m HD (12'0")	4.40 m HD (14'5")
H215 S	✓	✓

CW-70 Dedicated Coupler

Undercarriage	L-VG				
Counterweight	15.7 mt				
Boom Type	GP			ME	
Stick Length	2.92 m HD (9'6")	3.40 m HD (11'2")	4.40 m HD (14'5")	2.92 m (9'7")	3.40 m (11'2")
H215 S	✓	✓	✓	✓	✓

Hammer Technical Specifications

Matching – Wheeled Excavators

Match
 Working Range Front Only
 Allowed Usage on Machine Less Than 50%
 No Match

M314F

Pin-on

Undercarriage	Front and Rear Outriggers								
Counterweight	2.8 mt								
Boom Type	1 PC (short)			1 PC			VA		
Stick Length	2.00 m (6'7")	2.30 m (7'7")	2.60 m (8'6")	2.00 m (6'7")	2.30 m (7'7")	2.60 m (8'6")	2.00 m (6'7")	2.30 m (7'7")	2.60 m (8'6")
H110 S	✓	✓	✓	✓	✓	✓	✓	✓	✓
H115 S	✓	✓	✓	✓	✓	✓	✓	✓	✓

Pin-on (continued)

Undercarriage	Front and Rear Outriggers								
Counterweight	3.3 mt								
Boom Type	1 PC (short)			1 PC			VA		
Stick Length	2.00 m (6'7")	2.30 m (7'7")	2.60 m (8'6")	2.00 m (6'7")	2.30 m (7'7")	2.60 m (8'6")	2.00 m (6'7")	2.30 m (7'7")	2.60 m (8'6")
H110 S	✓	✓	✓	✓	✓	✓	✓	✓	✓
H115 S	✓	✓	✓	✓	✓	✓	✓	✓	✓

Pin-on (continued)

Undercarriage	Front Blade; Rear Outriggers								
Counterweight	2.8 mt								
Boom Type	1 PC (short)			1 PC			VA		
Stick Length	2.00 m (6'7")	2.30 m (7'7")	2.60 m (8'6")	2.00 m (6'7")	2.30 m (7'7")	2.60 m (8'6")	2.00 m (6'7")	2.30 m (7'7")	2.60 m (8'6")
H110 S	✓	✓	✓	✓	✓	✓	✓	✓	✓
H115 S	✓	✓	✓	✓	✓	✓	✓	✓	✓

Pin-on (continued)

Undercarriage	Front Blade; Rear Outriggers								
Counterweight	3.3 mt								
Boom Type	1 PC (short)			1 PC			VA		
Stick Length	2.00 m (6'7")	2.30 m (7'7")	2.60 m (8'6")	2.00 m (6'7")	2.30 m (7'7")	2.60 m (8'6")	2.00 m (6'7")	2.30 m (7'7")	2.60 m (8'6")
H110 S	✓	✓	✓	✓	✓	✓	✓	✓	✓
H115 S	✓	✓	✓	✓	✓	✓	✓	✓	✓

Pin-on (continued)

Undercarriage	Rear Blade								
Counterweight	2.8 mt								
Boom Type	1 PC (short)			1 PC			VA		
Stick Length	2.00 m (6'7")	2.30 m (7'7")	2.60 m (8'6")	2.00 m (6'7")	2.30 m (7'7")	2.60 m (8'6")	2.00 m (6'7")	2.30 m (7'7")	2.60 m (8'6")
H110 S	✓	✓	✓	✓	✓	✓	✓	✓	✓
H115 S	✓	✓	✓	✓	✓	✓	✓	✓	✓

Pin-on (continued)

Undercarriage	Rear Blade								
Counterweight	3.3 mt								
Boom Type	1 PC (short)			1 PC			VA		
Stick Length	2.00 m (6'7")	2.30 m (7'7")	2.60 m (8'6")	2.00 m (6'7")	2.30 m (7'7")	2.60 m (8'6")	2.00 m (6'7")	2.30 m (7'7")	2.60 m (8'6")
H110 S	✓	✓	✓	✓	✓	✓	✓	✓	✓
H115 S	✓	✓	✓	✓	✓	✓	✓	✓	✓

(continued on next page)

Matching – Wheeled Excavators (continued)

Match
 Working Range Front Only
 Allowed Usage on Machine Less Than 50%
 No Match

M314F (continued)

Cat Pin Grabber Coupler

Undercarriage	Front and Rear Outriggers								
Counterweight	2.8 mt								
Boom Type	1 PC (short)			1 PC			VA		
Stick Length	2.00 m (6'7")	2.30 m (7'7")	2.60 m (8'6")	2.00 m (6'7")	2.30 m (7'7")	2.60 m (8'6")	2.00 m (6'7")	2.30 m (7'7")	2.60 m (8'6")
H110 S	✓	✓	✓	✓	✓	✓	✓	✓	✓
H115 S	✓	✓	✓	✓	✓	✓	✓	✓	✓

Cat Pin Grabber Coupler (continued)

Undercarriage	Front and Rear Outriggers								
Counterweight	3.3 mt								
Boom Type	1 PC (short)			1 PC			VA		
Stick Length	2.00 m (6'7")	2.30 m (7'7")	2.60 m (8'6")	2.00 m (6'7")	2.30 m (7'7")	2.60 m (8'6")	2.00 m (6'7")	2.30 m (7'7")	2.60 m (8'6")
H110 S	✓	✓	✓	✓	✓	✓	✓	✓	✓
H115 S	✓	✓	✓	✓	✓	✓	✓	✓	✓

Cat Pin Grabber Coupler (continued)

Undercarriage	Front Blade; Rear Outriggers								
Counterweight	2.8 mt								
Boom Type	1 PC (short)			1 PC			VA		
Stick Length	2.00 m (6'7")	2.30 m (7'7")	2.60 m (8'6")	2.00 m (6'7")	2.30 m (7'7")	2.60 m (8'6")	2.00 m (6'7")	2.30 m (7'7")	2.60 m (8'6")
H110 S	✓	✓	✓	✓	✓	✓	✓	✓	✓
H115 S	✓	✓	✓	✓	✓	✓	✓	✓	✓

Cat Pin Grabber Coupler (continued)

Undercarriage	Front Blade; Rear Outriggers								
Counterweight	3.3 mt								
Boom Type	1 PC (short)			1 PC			VA		
Stick Length	2.00 m (6'7")	2.30 m (7'7")	2.60 m (8'6")	2.00 m (6'7")	2.30 m (7'7")	2.60 m (8'6")	2.00 m (6'7")	2.30 m (7'7")	2.60 m (8'6")
H110 S	✓	✓	✓	✓	✓	✓	✓	✓	✓
H115 S	✓	✓	✓	✓	✓	✓	✓	✓	✓

Cat Pin Grabber Coupler (continued)

Undercarriage	Rear Blade								
Counterweight	2.8 mt								
Boom Type	1 PC (short)			1 PC			VA		
Stick Length	2.00 m (6'7")	2.30 m (7'7")	2.60 m (8'6")	2.00 m (6'7")	2.30 m (7'7")	2.60 m (8'6")	2.00 m (6'7")	2.30 m (7'7")	
H110 S	✓	✓	✓	✓	✓	✓	✓	✓*	
H115 S	✓	✓	✓	✓	✓	✓*	✓*		

Cat Pin Grabber Coupler (continued)

Undercarriage	Rear Blade								
Counterweight	3.3 mt								
Boom Type	1 PC (short)			1 PC			VA		
Stick Length	2.00 m (6'7")	2.30 m (7'7")	2.60 m (8'6")	2.00 m (6'7")	2.30 m (7'7")	2.60 m (8'6")	2.00 m (6'7")	2.30 m (7'7")	2.60 m (8'6")
H110 S	✓	✓	✓	✓	✓	✓	✓	✓	✓
H115 S	✓	✓	✓	✓	✓	✓	✓	✓	✓*

(continued on next page)

Hammer Technical Specifications

Matching – Wheeled Excavators *(continued)*

Match
 Working Range Front Only
 Allowed Usage on Machine Less Than 50%
 No Match

M314F *(continued)*

CW-20 S Dedicated Coupler

Undercarriage	Front and Rear Outriggers								
Counterweight	2.8 mt								
Boom Type	1 PC (short)			1 PC			VA		
Stick Length	2.00 m (6'7")	2.30 m (7'7")	2.60 m (8'6")	2.00 m (6'7")	2.30 m (7'7")	2.60 m (8'6")	2.00 m (6'7")	2.30 m (7'7")	2.60 m (8'6")
H110 S	✓	✓	✓	✓	✓	✓	✓	✓	✓
H115 S	✓	✓	✓	✓	✓	✓			

CW-20 S Dedicated Coupler *(continued)*

Undercarriage	Front and Rear Outriggers								
Counterweight	3.3 mt								
Boom Type	1 PC (short)			1 PC			VA		
Stick Length	2.00 m (6'7")	2.30 m (7'7")	2.60 m (8'6")	2.00 m (6'7")	2.30 m (7'7")	2.60 m (8'6")	2.00 m (6'7")	2.30 m (7'7")	2.60 m (8'6")
H110 S	✓	✓	✓	✓	✓	✓	✓	✓	✓
H115 S	✓	✓	✓	✓	✓	✓			

CW-20 S Dedicated Coupler *(continued)*

Undercarriage	Front Blade; Rear Outriggers								
Counterweight	2.8 mt								
Boom Type	1 PC (short)			1 PC			VA		
Stick Length	2.00 m (6'7")	2.30 m (7'7")	2.60 m (8'6")	2.00 m (6'7")	2.30 m (7'7")	2.60 m (8'6")	2.00 m (6'7")	2.30 m (7'7")	2.60 m (8'6")
H110 S	✓	✓	✓	✓	✓	✓	✓	✓	✓
H115 S	✓	✓	✓	✓	✓	✓			

CW-20 S Dedicated Coupler *(continued)*

Undercarriage	Front Blade; Rear Outriggers								
Counterweight	3.3 mt								
Boom Type	1 PC (short)			1 PC			VA		
Stick Length	2.00 m (6'7")	2.30 m (7'7")	2.60 m (8'6")	2.00 m (6'7")	2.30 m (7'7")	2.60 m (8'6")	2.00 m (6'7")	2.30 m (7'7")	2.60 m (8'6")
H110 S	✓	✓	✓	✓	✓	✓	✓	✓	✓
H115 S	✓	✓	✓	✓	✓	✓			

CW-20 S Dedicated Coupler *(continued)*

Undercarriage	Rear Blade								
Counterweight	2.8 mt								
Boom Type	1 PC (short)			1 PC			VA		
Stick Length	2.00 m (6'7")	2.30 m (7'7")	2.60 m (8'6")	2.00 m (6'7")	2.30 m (7'7")	2.60 m (8'6")	2.00 m (6'7")	2.30 m (7'7")	2.60 m (8'6")
H110 S	✓	✓	✓	✓	✓	✓	✓	✓	✓*
H115 S	✓	✓	✓	✓	✓	✓			

CW-20 S Dedicated Coupler *(continued)*

Undercarriage	Rear Blade								
Counterweight	3.3 mt								
Boom Type	1 PC (short)			1 PC			VA		
Stick Length	2.00 m (6'7")	2.30 m (7'7")	2.60 m (8'6")	2.00 m (6'7")	2.30 m (7'7")	2.60 m (8'6")	2.00 m (6'7")	2.30 m (7'7")	2.60 m (8'6")
H110 S	✓	✓	✓	✓	✓	✓	✓	✓	✓
H115 S	✓	✓	✓	✓	✓	✓			

(continued on next page)

Matching – Wheeled Excavators (continued)

Match
 * Working Range Front Only
 † Allowed Usage on Machine Less Than 50%
 No Match

M314F (continued)

CW-20 Dedicated Coupler

Undercarriage	Front and Rear Outriggers								
Counterweight	2.8 mt								
Boom Type	1 PC (short)			1 PC			VA		
Stick Length	2.00 m (6'7")	2.30 m (7'7")	2.60 m (8'6")	2.00 m (6'7")	2.30 m (7'7")	2.60 m (8'6")	2.00 m (6'7")	2.30 m (7'7")	2.60 m (8'6")
H110 S	✓	✓	✓	✓	✓	✓	✓	✓	✓
H115 S	✓	✓	✓	✓	✓	✓		✓	✓

CW-20 Dedicated Coupler (continued)

Undercarriage	Front and Rear Outriggers								
Counterweight	3.3 mt								
Boom Type	1 PC (short)			1 PC			VA		
Stick Length	2.00 m (6'7")	2.30 m (7'7")	2.60 m (8'6")	2.00 m (6'7")	2.30 m (7'7")	2.60 m (8'6")	2.00 m (6'7")	2.30 m (7'7")	2.60 m (8'6")
H110 S	✓	✓	✓	✓	✓	✓	✓	✓	✓
H115 S	✓	✓	✓	✓	✓	✓		✓	✓

CW-20 Dedicated Coupler (continued)

Undercarriage	Front Blade; Rear Outriggers								
Counterweight	2.8 mt								
Boom Type	1 PC (short)			1 PC			VA		
Stick Length	2.00 m (6'7")	2.30 m (7'7")	2.60 m (8'6")	2.00 m (6'7")	2.30 m (7'7")	2.60 m (8'6")	2.00 m (6'7")	2.30 m (7'7")	2.60 m (8'6")
H110 S	✓	✓	✓	✓	✓	✓	✓	✓	✓
H115 S	✓	✓	✓	✓	✓	✓		✓	✓

CW-20 Dedicated Coupler (continued)

Undercarriage	Front Blade; Rear Outriggers								
Counterweight	3.3 mt								
Boom Type	1 PC (short)			1 PC			VA		
Stick Length	2.00 m (6'7")	2.30 m (7'7")	2.60 m (8'6")	2.00 m (6'7")	2.30 m (7'7")	2.60 m (8'6")	2.00 m (6'7")	2.30 m (7'7")	2.60 m (8'6")
H110 S	✓	✓	✓	✓	✓	✓	✓	✓	✓
H115 S	✓	✓	✓	✓	✓	✓		✓	✓

CW-20 Dedicated Coupler (continued)

Undercarriage	Rear Blade								
Counterweight	2.8 mt								
Boom Type	1 PC (short)			1 PC			VA		
Stick Length	2.00 m (6'7")	2.30 m (7'7")	2.60 m (8'6")	2.00 m (6'7")	2.30 m (7'7")	2.60 m (8'6")	2.00 m (6'7")	2.30 m (7'7")	2.60 m (8'6")
H110 S	✓	✓	✓	✓	✓	✓	✓	✓	✓*
H115 S	✓	✓	✓	✓	✓	✓		✓*	

CW-20 Dedicated Coupler (continued)

Undercarriage	Rear Blade								
Counterweight	3.3 mt								
Boom Type	1 PC (short)			1 PC			VA		
Stick Length	2.00 m (6'7")	2.30 m (7'7")	2.60 m (8'6")	2.00 m (6'7")	2.30 m (7'7")	2.60 m (8'6")	2.00 m (6'7")	2.30 m (7'7")	2.60 m (8'6")
H110 S	✓	✓	✓	✓	✓	✓	✓	✓	✓
H115 S	✓	✓	✓	✓	✓	✓		✓	✓*

(continued on next page)

Hammer Technical Specifications

Matching – Wheeled Excavators (continued)

Match
 Working Range Front Only
 Allowed Usage on Machine Less Than 50%
 No Match

M314

Pin-on

Undercarriage	Front and Rear Outriggers							
Counterweight	2.6 mt				3.1 mt			
Boom Type	1 PC		VA		1 PC		VA	
Stick Length	2.20 m (7'3")	2.50 m (8'2")	2.20 m (7'3")	2.50 m (8'2")	2.20 m (7'3")	2.50 m (8'2")	2.20 m (7'3")	2.50 m (8'2")
H110 S	✓	✓	✓	✓	✓	✓	✓	✓
H115 S	✓	✓	✓	✓	✓	✓	✓	✓

Pin-on (continued)

Undercarriage	Front Blade; Rear Outriggers							
Counterweight	2.6 mt				3.1 mt			
Boom Type	1 PC		VA		1 PC		VA	
Stick Length	2.20 m (7'3")	2.50 m (8'2")	2.20 m (7'3")	2.50 m (8'2")	2.20 m (7'3")	2.50 m (8'2")	2.20 m (7'3")	2.50 m (8'2")
H110 S	✓	✓	✓	✓	✓	✓	✓	✓
H115 S	✓	✓	✓	✓	✓	✓	✓	✓

Pin-on (continued)

Undercarriage	Front Outriggers; Rear Blade							
Counterweight	2.6 mt				3.1 mt			
Boom Type	1 PC		VA		1 PC		VA	
Stick Length	2.20 m (7'3")	2.50 m (8'2")	2.20 m (7'3")	2.50 m (8'2")	2.20 m (7'3")	2.50 m (8'2")	2.20 m (7'3")	2.50 m (8'2")
H110 S	✓	✓	✓	✓	✓	✓	✓	✓
H115 S	✓	✓	✓	✓	✓	✓	✓	✓

Pin-on (continued)

Undercarriage	Rear Blade							
Counterweight	2.6 mt				3.1 mt			
Boom Type	1 PC		VA		1 PC		VA	
Stick Length	2.20 m (7'3")	2.50 m (8'2")	2.20 m (7'3")	2.50 m (8'2")	2.20 m (7'3")	2.50 m (8'2")	2.20 m (7'3")	2.50 m (8'2")
H110 S	✓	✓	✓	✓	✓	✓	✓	✓
H115 S	✓	✓	✓	✓	✓	✓	✓	✓

Cat Pin Grabber Coupler

Undercarriage	Front and Rear Outriggers							
Counterweight	2.6 mt				3.1 mt			
Boom Type	1 PC		VA		1 PC		VA	
Stick Length	2.20 m (7'3")	2.50 m (8'2")	2.20 m (7'3")	2.50 m (8'2")	2.20 m (7'3")	2.50 m (8'2")	2.20 m (7'3")	2.50 m (8'2")
H110 S	✓	✓	✓	✓	✓	✓	✓	✓
H115 S	✓	✓	✓	✓	✓	✓	✓	✓

Cat Pin Grabber Coupler (continued)

Undercarriage	Front Blade; Rear Outriggers							
Counterweight	2.6 mt				3.1 mt			
Boom Type	1 PC		VA		1 PC		VA	
Stick Length	2.20 m (7'3")	2.50 m (8'2")	2.20 m (7'3")	2.50 m (8'2")	2.20 m (7'3")	2.50 m (8'2")	2.20 m (7'3")	2.50 m (8'2")
H110 S	✓	✓	✓	✓	✓	✓	✓	✓
H115 S	✓	✓	✓	✓	✓	✓	✓	✓

(continued on next page)

Hammer Technical Specifications

Matching – Wheeled Excavators (continued)

Match
 Working Range Front Only
 Allowed Usage on Machine Less Than 50%
 No Match

M314 (continued)

Cat Pin Grabber Coupler (continued)

Undercarriage	Front Outriggers; Rear Blade							
Counterweight	2.6 mt				3.1 mt			
Boom Type	1 PC		VA		1 PC		VA	
Stick Length	2.20 m (7'3")	2.50 m (8'2")	2.20 m (7'3")	2.50 m (8'2")	2.20 m (7'3")	2.50 m (8'2")	2.20 m (7'3")	2.50 m (8'2")
H110 S	✓	✓	✓	✓	✓	✓	✓	✓
H115 S	✓	✓	✓	✓	✓	✓	✓	✓

Cat Pin Grabber Coupler (continued)

Undercarriage	Rear Blade							
Counterweight	2.6 mt				3.1 mt			
Boom Type	1 PC		VA		1 PC		VA	
Stick Length	2.20 m (7'3")	2.50 m (8'2")	2.20 m (7'3")	2.50 m (8'2")	2.20 m (7'3")	2.50 m (8'2")	2.20 m (7'3")	2.50 m (8'2")
H110 S	✓	✓	✓	✓	✓	✓	✓	✓
H115 S	✓	✓	✓	✓*	✓	✓	✓	✓

CW-20 S Dedicated Coupler

Undercarriage	Front and Rear Outriggers							
Counterweight	2.6 mt				3.1 mt			
Boom Type	1 PC		VA		1 PC		VA	
Stick Length	2.20 m (7'3")	2.50 m (8'2")	2.20 m (7'3")	2.50 m (8'2")	2.20 m (7'3")	2.50 m (8'2")	2.20 m (7'3")	2.50 m (8'2")
H110 S	✓	✓	✓	✓	✓	✓	✓	✓
H115 S	✓	✓	✓	✓	✓	✓	✓	✓

CW-20 S Dedicated Coupler (continued)

Undercarriage	Front Blade; Rear Outriggers							
Counterweight	2.6 mt				3.1 mt			
Boom Type	1 PC		VA		1 PC		VA	
Stick Length	2.20 m (7'3")	2.50 m (8'2")	2.20 m (7'3")	2.50 m (8'2")	2.20 m (7'3")	2.50 m (8'2")	2.20 m (7'3")	2.50 m (8'2")
H110 S	✓	✓	✓	✓	✓	✓	✓	✓
H115 S	✓	✓	✓	✓	✓	✓	✓	✓

CW-20 S Dedicated Coupler (continued)

Undercarriage	Front Outriggers; Rear Blade							
Counterweight	2.6 mt				3.1 mt			
Boom Type	1 PC		VA		1 PC		VA	
Stick Length	2.20 m (7'3")	2.50 m (8'2")	2.20 m (7'3")	2.50 m (8'2")	2.20 m (7'3")	2.50 m (8'2")	2.20 m (7'3")	2.50 m (8'2")
H110 S	✓	✓	✓	✓	✓	✓	✓	✓
H115 S	✓	✓	✓	✓	✓	✓	✓	✓

CW-20 S Dedicated Coupler (continued)

Undercarriage	Rear Blade							
Counterweight	2.6 mt				3.1 mt			
Boom Type	1 PC		VA		1 PC		VA	
Stick Length	2.20 m (7'3")	2.50 m (8'2")	2.20 m (7'3")	2.50 m (8'2")	2.20 m (7'3")	2.50 m (8'2")	2.20 m (7'3")	2.50 m (8'2")
H110 S	✓	✓	✓	✓	✓	✓	✓	✓
H115 S	✓	✓	✓*	✓*	✓	✓	✓	✓

(continued on next page)

Hammer Technical Specifications

Matching – Wheeled Excavators (continued)

Match
 Working Range Front Only
 Allowed Usage on Machine Less Than 50%
 No Match

M314 (continued)

CW-20 Dedicated Coupler

Undercarriage	Front and Rear Outriggers							
Counterweight	2.6 mt				3.1 mt			
Boom Type	1 PC		VA		1 PC		VA	
Stick Length	2.20 m (7'3")	2.50 m (8'2")	2.20 m (7'3")	2.50 m (8'2")	2.20 m (7'3")	2.50 m (8'2")	2.20 m (7'3")	2.50 m (8'2")
H110 S	✓	✓	✓	✓	✓	✓	✓	✓
H115 S	✓	✓	✓	✓	✓	✓	✓	✓

CW-20 Dedicated Coupler (continued)

Undercarriage	Front Blade; Rear Outriggers							
Counterweight	2.6 mt				3.1 mt			
Boom Type	1 PC		VA		1 PC		VA	
Stick Length	2.20 m (7'3")	2.50 m (8'2")	2.20 m (7'3")	2.50 m (8'2")	2.20 m (7'3")	2.50 m (8'2")	2.20 m (7'3")	2.50 m (8'2")
H110 S	✓	✓	✓	✓	✓	✓	✓	✓
H115 S	✓	✓	✓	✓	✓	✓	✓	✓

CW-20 Dedicated Coupler (continued)

Undercarriage	Front Outriggers; Rear Blade							
Counterweight	2.6 mt				3.1 mt			
Boom Type	1 PC		VA		1 PC		VA	
Stick Length	2.20 m (7'3")	2.50 m (8'2")	2.20 m (7'3")	2.50 m (8'2")	2.20 m (7'3")	2.50 m (8'2")	2.20 m (7'3")	2.50 m (8'2")
H110 S	✓	✓	✓	✓	✓	✓	✓	✓
H115 S	✓	✓	✓	✓	✓	✓	✓	✓

CW-20 Dedicated Coupler (continued)

Undercarriage	Rear Blade							
Counterweight	2.6 mt				3.1 mt			
Boom Type	1 PC		VA		1 PC		VA	
Stick Length	2.20 m (7'3")	2.50 m (8'2")	2.20 m (7'3")	2.50 m (8'2")	2.20 m (7'3")	2.50 m (8'2")	2.20 m (7'3")	2.50 m (8'2")
H110 S	✓	✓	✓	✓*	✓	✓	✓	✓
H115 S	✓	✓	✓*		✓	✓	✓	✓

S60 Dedicated Coupler

Undercarriage	Front and Rear Outriggers							
Counterweight	2.6 mt				3.1 mt			
Boom Type	1 PC		VA		1 PC		VA	
Stick Length	2.20 m (7'3")	2.50 m (8'2")	2.20 m (7'3")	2.50 m (8'2")	2.20 m (7'3")	2.50 m (8'2")	2.20 m (7'3")	2.50 m (8'2")
H110 S	✓	✓	✓	✓	✓	✓	✓	✓
H115 S	✓	✓	✓	✓	✓	✓	✓	✓

S60 Dedicated Coupler (continued)

Undercarriage	Front Blade; Rear Outriggers							
Counterweight	2.6 mt				3.1 mt			
Boom Type	1 PC		VA		1 PC		VA	
Stick Length	2.20 m (7'3")	2.50 m (8'2")	2.20 m (7'3")	2.50 m (8'2")	2.20 m (7'3")	2.50 m (8'2")	2.20 m (7'3")	2.50 m (8'2")
H110 S	✓	✓	✓	✓	✓	✓	✓	✓
H115 S	✓	✓	✓	✓	✓	✓	✓	✓

(continued on next page)

Matching – Wheeled Excavators (continued)

Match
 * Working Range Front Only
 † Allowed Usage on Machine Less Than 50%
 No Match

M314 (continued)

S60 Dedicated Coupler (continued)

Undercarriage	Front Outriggers; Rear Blade							
Counterweight	2.6 mt				3.1 mt			
Boom Type	1 PC		VA		1 PC		VA	
Stick Length	2.20 m (7'3")	2.50 m (8'2")	2.20 m (7'3")	2.50 m (8'2")	2.20 m (7'3")	2.50 m (8'2")	2.20 m (7'3")	2.50 m (8'2")
H110 S	✓	✓	✓	✓	✓	✓	✓	✓
H115 S	✓	✓	✓	✓	✓	✓	✓	✓

S60 Dedicated Coupler (continued)

Undercarriage	Rear Blade							
Counterweight	2.6 mt				3.1 mt			
Boom Type	1 PC		VA		1 PC		VA	
Stick Length	2.20 m (7'3")	2.50 m (8'2")	2.20 m (7'3")	2.50 m (8'2")	2.20 m (7'3")	2.50 m (8'2")	2.20 m (7'3")	2.50 m (8'2")
H110 S	✓	✓	✓	✓	✓	✓	✓	✓
H115 S	✓	✓	✓	✓	✓	✓	✓	✓

HCS60 Dedicated Coupler

Undercarriage	Front and Rear Outriggers							
Counterweight	2.6 mt				3.1 mt			
Boom Type	1 PC		VA		1 PC		VA	
Stick Length	2.20 m (7'3")	2.50 m (8'2")	2.20 m (7'3")	2.50 m (8'2")	2.20 m (7'3")	2.50 m (8'2")	2.20 m (7'3")	2.50 m (8'2")
H110 S	✓	✓	✓	✓	✓	✓	✓	✓
H115 S	✓	✓	✓	✓	✓	✓	✓	✓

HCS60 Dedicated Coupler (continued)

Undercarriage	Front Blade; Rear Outriggers							
Counterweight	2.6 mt				3.1 mt			
Boom Type	1 PC		VA		1 PC		VA	
Stick Length	2.20 m (7'3")	2.50 m (8'2")	2.20 m (7'3")	2.50 m (8'2")	2.20 m (7'3")	2.50 m (8'2")	2.20 m (7'3")	2.50 m (8'2")
H110 S	✓	✓	✓	✓	✓	✓	✓	✓
H115 S	✓	✓	✓	✓	✓	✓	✓	✓

HCS60 Dedicated Coupler (continued)

Undercarriage	Front Outriggers; Rear Blade							
Counterweight	2.6 mt				3.1 mt			
Boom Type	1 PC		VA		1 PC		VA	
Stick Length	2.20 m (7'3")	2.50 m (8'2")	2.20 m (7'3")	2.50 m (8'2")	2.20 m (7'3")	2.50 m (8'2")	2.20 m (7'3")	2.50 m (8'2")
H110 S	✓	✓	✓	✓	✓	✓	✓	✓
H115 S	✓	✓	✓	✓	✓	✓	✓	✓

HCS60 Dedicated Coupler (continued)

Undercarriage	Rear Blade							
Counterweight	2.6 mt				3.1 mt			
Boom Type	1 PC		VA		1 PC		VA	
Stick Length	2.20 m (7'3")	2.50 m (8'2")	2.20 m (7'3")	2.50 m (8'2")	2.20 m (7'3")	2.50 m (8'2")	2.20 m (7'3")	2.50 m (8'2")
H110 S	✓	✓	✓	✓	✓	✓	✓	✓
H115 S	✓	✓	✓	✓	✓	✓	✓	✓

(continued on next page)

Hammer Technical Specifications

Matching – Wheeled Excavators *(continued)*

Match
 Working Range Front Only
 Allowed Usage on Machine Less Than 50%
 No Match

M314 *(continued)*

HCS65 Dedicated Coupler

Undercarriage	Front and Rear Outriggers							
Counterweight	2.6 mt				3.1 mt			
Boom Type	1 PC		VA		1 PC		VA	
Stick Length	2.20 m (7'3")	2.50 m (8'2")	2.20 m (7'3")	2.50 m (8'2")	2.20 m (7'3")	2.50 m (8'2")	2.20 m (7'3")	2.50 m (8'2")
H110 S	✓	✓	✓	✓	✓	✓	✓	✓
H115 S	✓	✓	✓	✓	✓	✓	✓	✓

HCS65 Dedicated Coupler *(continued)*

Undercarriage	Front Blade; Rear Outriggers							
Counterweight	2.6 mt				3.1 mt			
Boom Type	1 PC		VA		1 PC		VA	
Stick Length	2.20 m (7'3")	2.50 m (8'2")	2.20 m (7'3")	2.50 m (8'2")	2.20 m (7'3")	2.50 m (8'2")	2.20 m (7'3")	2.50 m (8'2")
H110 S	✓	✓	✓	✓	✓	✓	✓	✓
H115 S	✓	✓	✓	✓	✓	✓	✓	✓

HCS65 Dedicated Coupler *(continued)*

Undercarriage	Front Outriggers; Rear Blade							
Counterweight	2.6 mt				3.1 mt			
Boom Type	1 PC		VA		1 PC		VA	
Stick Length	2.20 m (7'3")	2.50 m (8'2")	2.20 m (7'3")	2.50 m (8'2")	2.20 m (7'3")	2.50 m (8'2")	2.20 m (7'3")	2.50 m (8'2")
H110 S	✓	✓	✓	✓	✓	✓	✓	✓
H115 S	✓	✓	✓	✓	✓	✓	✓	✓

HCS65 Dedicated Coupler *(continued)*

Undercarriage	Rear Blade							
Counterweight	2.6 mt				3.1 mt			
Boom Type	1 PC		VA		1 PC		VA	
Stick Length	2.20 m (7'3")	2.50 m (8'2")	2.20 m (7'3")	2.50 m (8'2")	2.20 m (7'3")	2.50 m (8'2")	2.20 m (7'3")	2.50 m (8'2")
H110 S	✓	✓	✓	✓	✓	✓	✓	✓
H115 S	✓	✓	✓	✓	✓	✓	✓	✓

Tilt-Rotator TRS10 with CW20s Dedicated Coupler

Undercarriage	Front and Rear Outriggers				Front Blade; Rear Outriggers			
Counterweight	2.6 mt		3.1 mt		2.6 mt		3.1 mt	
Boom Type	1 PC		1 PC		1 PC		1 PC	
Stick Length	2.20 m (7'3")	2.50 m (8'2")	2.20 m (7'3")	2.50 m (8'2")	2.20 m (7'3")	2.50 m (8'2")	2.20 m (7'3")	2.50 m (8'2")
H110 S	✓	✓	✓	✓	✓	✓	✓	✓

Tilt-Rotator TRS10 with CW20s Dedicated Coupler *(continued)*

Undercarriage	Front Outriggers; Rear Blade				Rear Blade	
Counterweight	2.6 mt		3.1 mt		3.1 mt	
Boom Type	1 PC		1 PC		1 PC	
Stick Length	2.20 m (7'3")	2.50 m (8'2")	2.20 m (7'3")	2.50 m (8'2")	2.20 m (7'3")	2.50 m (8'2")
H110 S	✓	✓	✓	✓	✓	✓

(continued on next page)

Matching – Wheeled Excavators (continued)

Match
 Working Range Front Only
 Allowed Usage on Machine Less Than 50%
 No Match

M314 (continued)

CW20 S – Tilt-Rotator TRS10 – CW20S

Undercarriage	Front and Rear Outriggers		Front Blade; Rear Outriggers		Front Outriggers; Rear Blade	
Counterweight	2.6 mt	3.1 mt	2.6 mt	3.1 mt	2.6 mt	3.1 mt
Boom Type	1 PC	1 PC	1 PC	1 PC	1 PC	1 PC
Stick Length	2.20 m (7'3")	2.20 m (7'3")	2.20 m (7'3")	2.20 m (7'3")	2.20 m (7'3")	2.20 m (7'3")
H110 S	✓	✓	✓	✓	✓	✓

Tilt-Rotator TRS10 with CW20 Dedicated Coupler

Undercarriage	Front and Rear Outriggers					
Counterweight	2.6 mt			3.1 mt		
Boom Type	1 PC		VA	1 PC		VA
Stick Length	2.20 m (7'3")	2.50 m (8'2")	2.20 m (7'3")	2.20 m (7'3")	2.50 m (8'2")	2.20 m (7'3")
H110 S	✓	✓	✓	✓	✓	✓

Tilt-Rotator TRS10 with CW20 Dedicated Coupler (continued)

Undercarriage	Front Blade; Rear Outriggers					
Counterweight	2.6 mt			3.1 mt		
Boom Type	1 PC		VA	1 PC		VA
Stick Length	2.20 m (7'3")	2.50 m (8'2")	2.20 m (7'3")	2.20 m (7'3")	2.50 m (8'2")	2.20 m (7'3")
H110 S	✓	✓	✓	✓	✓	✓

Tilt-Rotator TRS10 with CW20 Dedicated Coupler (continued)

Undercarriage	Front Outriggers; Rear Blade						Rear Blade	
Counterweight	2.6 mt			3.1 mt			3.1 mt	
Boom Type	1 PC		VA	1 PC		VA	1 PC	
Stick Length	2.20 m (7'3")	2.50 m (8'2")	2.20 m (7'3")	2.20 m (7'3")	2.50 m (8'2")	2.20 m (7'3")	2.20 m (7'3")	2.50 m (8'2")
H110 S	✓	✓	✓	✓	✓	✓	✓	✓

Tilt-Rotator TRS10 with S60 Dedicated Coupler

Undercarriage	Front and Rear Outriggers							
Counterweight	2.6 mt				3.1 mt			
Boom Type	1 PC		VA		1 PC		VA	
Stick Length	2.20 m (7'3")	2.50 m (8'2")	2.20 m (7'3")	2.50 m (8'2")	2.20 m (7'3")	2.50 m (8'2")	2.20 m (7'3")	2.50 m (8'2")
H110 S	✓	✓	✓	✓	✓	✓	✓	✓

Tilt-Rotator TRS10 with S60 Dedicated Coupler (continued)

Undercarriage	Front Blade; Rear Outriggers							
Counterweight	2.6 mt				3.1 mt			
Boom Type	1 PC		VA		1 PC		VA	
Stick Length	2.20 m (7'3")	2.50 m (8'2")	2.20 m (7'3")	2.50 m (8'2")	2.20 m (7'3")	2.50 m (8'2")	2.20 m (7'3")	2.50 m (8'2")
H110 S	✓	✓	✓	✓	✓	✓	✓	✓

Tilt-Rotator TRS10 with S60 Dedicated Coupler (continued)

Undercarriage	Front Outriggers; Rear Blade							
Counterweight	2.6 mt				3.1 mt			
Boom Type	1 PC		VA		1 PC		VA	
Stick Length	2.20 m (7'3")	2.50 m (8'2")	2.20 m (7'3")	2.50 m (8'2")	2.20 m (7'3")	2.50 m (8'2")	2.20 m (7'3")	2.50 m (8'2")
H110 S	✓	✓	✓	✓	✓	✓	✓	✓

(continued on next page)

Hammer Technical Specifications

Matching – Wheeled Excavators *(continued)*

Match
 Working Range Front Only
 Allowed Usage on Machine Less Than 50%
 No Match

M314 *(continued)*

Tilt-Rotator TRS10 with S60 Dedicated Coupler *(continued)*

Undercarriage	Rear Blade					
Counterweight	2.6 mt			3.1 mt		
Boom Type	1 PC		1 PC		VA	
Stick Length	2.20 m (7'3")	2.50 m (8'2")	2.20 m (7'3")	2.50 m (8'2")	2.20 m (7'3")	2.50 m (8'2")
H110 S	✓	✓	✓	✓	✓	✓

S60 – Tilt-Rotator TRS10 – S60

Undercarriage	Front and Rear Outriggers							
Counterweight	2.6 mt				3.1 mt			
Boom Type	1 PC		VA		1 PC		VA	
Stick Length	2.20 m (7'3")	2.50 m (8'2")	2.20 m (7'3")	2.50 m (8'2")	2.20 m (7'3")	2.50 m (8'2")	2.20 m (7'3")	2.50 m (8'2")
H110 S	✓	✓	✓	✓	✓	✓	✓	✓

S60 – Tilt-Rotator TRS10 – S60 *(continued)*

Undercarriage	Front Blade; Rear Outriggers							
Counterweight	2.6 mt				3.1 mt			
Boom Type	1 PC		VA		1 PC		VA	
Stick Length	2.20 m (7'3")	2.50 m (8'2")	2.20 m (7'3")	2.50 m (8'2")	2.20 m (7'3")	2.50 m (8'2")	2.20 m (7'3")	2.50 m (8'2")
H110 S	✓	✓	✓	✓	✓	✓	✓	✓

S60 – Tilt-Rotator TRS10 – S60 *(continued)*

Undercarriage	Front Outriggers; Rear Blade							
Counterweight	2.6 mt				3.1 mt			
Boom Type	1 PC		VA		1 PC		VA	
Stick Length	2.20 m (7'3")	2.50 m (8'2")	2.20 m (7'3")	2.50 m (8'2")	2.20 m (7'3")	2.50 m (8'2")	2.20 m (7'3")	2.50 m (8'2")
H110 S	✓	✓	✓	✓	✓	✓	✓	✓

S60 – Tilt-Rotator TRS10 – S60 *(continued)*

Undercarriage	Rear Blade		
Counterweight	2.6 mt	3.1 mt	
Boom Type	1 PC		
Stick Length	2.20 m (7'3")	2.20 m (7'3")	2.50 m (8'2")
H110 S	✓	✓	✓

Tilt-Rotator TRS10 with HCS60 Dedicated Coupler

Undercarriage	Front and Rear Outriggers							
Counterweight	2.6 mt				3.1 mt			
Boom Type	1 PC		VA		1 PC		VA	
Stick Length	2.20 m (7'3")	2.50 m (8'2")	2.20 m (7'3")	2.50 m (8'2")	2.20 m (7'3")	2.50 m (8'2")	2.20 m (7'3")	2.50 m (8'2")
H110 S	✓	✓	✓	✓	✓	✓	✓	✓

Tilt-Rotator TRS10 with HCS60 Dedicated Coupler *(continued)*

Undercarriage	Front Blade; Rear Outriggers							
Counterweight	2.6 mt				3.1 mt			
Boom Type	1 PC		VA		1 PC		VA	
Stick Length	2.20 m (7'3")	2.50 m (8'2")	2.20 m (7'3")	2.50 m (8'2")	2.20 m (7'3")	2.50 m (8'2")	2.20 m (7'3")	2.50 m (8'2")
H110 S	✓	✓	✓	✓	✓	✓	✓	✓

(continued on next page)

Matching – Wheeled Excavators (continued)

Match
 Working Range Front Only
 Allowed Usage on Machine Less Than 50%
 No Match

M314 (continued)

Tilt-Rotator TRS10 with HCS60 Dedicated Coupler (continued)

Undercarriage	Front Outriggers; Rear Blade							
Counterweight	2.6 mt				3.1 mt			
Boom Type	1 PC		VA		1 PC		VA	
Stick Length	2.20 m (7'3")	2.50 m (8'2")	2.20 m (7'3")	2.50 m (8'2")	2.20 m (7'3")	2.50 m (8'2")	2.20 m (7'3")	2.50 m (8'2")
H110 S	✓	✓	✓	✓	✓	✓	✓	✓

Tilt-Rotator TRS10 with HCS60 Dedicated Coupler (continued)

Undercarriage	Rear Blade				
Counterweight	2.6 mt		3.1 mt		
Boom Type	1 PC				
Stick Length	2.20 m (7'3")	2.50 m (8'2")	2.20 m (7'3")	2.50 m (8'2")	2.20 m (7'3")
H110 S	✓	✓	✓	✓	✓

HCS60 – Tilt-Rotator TRS10 – HCSS60

Undercarriage	Front and Rear Outriggers							
Counterweight	2.6 mt				3.1 mt			
Boom Type	1 PC		VA		1 PC		VA	
Stick Length	2.20 m (7'3")	2.50 m (8'2")	2.20 m (7'3")	2.50 m (8'2")	2.20 m (7'3")	2.50 m (8'2")	2.20 m (7'3")	2.50 m (8'2")
H110 S	✓	✓	✓	✓	✓	✓	✓	✓

HCS60 – Tilt-Rotator TRS10 – HCSS60 (continued)

Undercarriage	Front Blade; Rear Outriggers							
Counterweight	2.6 mt				3.1 mt			
Boom Type	1 PC		VA		1 PC		VA	
Stick Length	2.20 m (7'3")	2.50 m (8'2")	2.20 m (7'3")	2.50 m (8'2")	2.20 m (7'3")	2.50 m (8'2")	2.20 m (7'3")	2.50 m (8'2")
H110 S	✓	✓	✓	✓	✓	✓	✓	✓

HCS60 – Tilt-Rotator TRS10 – HCSS60 (continued)

Undercarriage	Front Outriggers; Rear Blade							
Counterweight	2.6 mt				3.1 mt			
Boom Type	1 PC		VA		1 PC		VA	
Stick Length	2.20 m (7'3")	2.50 m (8'2")	2.20 m (7'3")	2.50 m (8'2")	2.20 m (7'3")	2.50 m (8'2")	2.20 m (7'3")	2.50 m (8'2")
H110 S	✓	✓	✓	✓	✓	✓	✓	✓

HCS60 – Tilt-Rotator TRS10 – HCSS60 (continued)

Undercarriage	Rear Blade	
Counterweight	3.1 mt	
Boom Type	1 PC	
Stick Length	2.20 m (7'3")	2.50 m (8'2")
H110 S	✓	✓

M315D2

Pin-on

Undercarriage	Front Outriggers; Rear Blade					
Counterweight	2.9 mt					
Boom Type	1 PC (short)		1 PC		VA	
Stick Length	2.00 m (6'7")	2.30 m (7'7")	2.00 m (6'7")	2.30 m (7'7")	2.00 m (6'7")	2.30 m (7'7")
H110 S	✓	✓	✓	✓	✓	✓
H115 S	✓	✓	✓	✓	✓	✓

(continued on next page)

Hammer Technical Specifications

Matching – Wheeled Excavators (continued)

Match
 * Working Range Front Only
 † Allowed Usage on Machine Less Than 50%
 No Match

M315D2 (continued)

Pin-on (continued)

Undercarriage	Front Outriggers; Rear Blade					
Counterweight	3.3 mt					
Boom Type	1 PC (short)		1 PC		VA	
Stick Length	2.00 m (6'7")	2.30 m (7'7")	2.00 m (6'7")	2.30 m (7'7")	2.00 m (6'7")	2.30 m (7'7")
H110 S	✓	✓	✓	✓	✓	✓
H115 S	✓	✓	✓	✓	✓	✓

Pin-on (continued)

Undercarriage	Rear Blade					
Counterweight	2.9 mt					
Boom Type	1 PC (short)		1 PC		VA	
Stick Length	2.00 m (6'7")	2.30 m (7'7")	2.00 m (6'7")	2.30 m (7'7")	2.00 m (6'7")	2.30 m (7'7")
H110 S	✓	✓	✓	✓	✓	✓
H115 S	✓	✓	✓	✓	✓	✓

Pin-on (continued)

Undercarriage	Rear Blade					
Counterweight	3.3 mt					
Boom Type	1 PC (short)		1 PC		VA	
Stick Length	2.00 m (6'7")	2.30 m (7'7")	2.00 m (6'7")	2.30 m (7'7")	2.00 m (6'7")	2.30 m (7'7")
H110 S	✓	✓	✓	✓	✓	✓
H115 S	✓	✓	✓	✓	✓	✓

Cat Pin Grabber Coupler

Undercarriage	Front Outriggers; Rear Blade					
Counterweight	2.9 mt					
Boom Type	1 PC (short)		1 PC		VA	
Stick Length	2.00 m (6'7")	2.30 m (7'7")	2.00 m (6'7")	2.30 m (7'7")	2.00 m (6'7")	2.30 m (7'7")
H110 S	✓	✓	✓	✓	✓	✓
H115 S	✓	✓	✓	✓	✓	✓

Cat Pin Grabber Coupler (continued)

Undercarriage	Front Outriggers; Rear Blade					
Counterweight	3.3 mt					
Boom Type	1 PC (short)		1 PC		VA	
Stick Length	2.00 m (6'7")	2.30 m (7'7")	2.00 m (6'7")	2.30 m (7'7")	2.00 m (6'7")	2.30 m (7'7")
H110 S	✓	✓	✓	✓	✓	✓
H115 S	✓	✓	✓	✓	✓	✓

Cat Pin Grabber Coupler (continued)

Undercarriage	Rear Blade					
Counterweight	2.9 mt					
Boom Type	1 PC (short)		1 PC		VA	
Stick Length	2.00 m (6'7")	2.30 m (7'7")	2.00 m (6'7")	2.30 m (7'7")	2.00 m (6'7")	2.30 m (7'7")
H110 S	✓	✓	✓	✓	✓	✓
H115 S	✓	✓	✓	✓	✓	✓*

(continued on next page)

Matching – Wheeled Excavators *(continued)*

Match
 * Working Range Front Only
 † Allowed Usage on Machine Less Than 50%
 No Match

M315D2 *(continued)*

Cat Pin Grabber Coupler *(continued)*

Undercarriage	Rear Blade					
Counterweight	3.3 mt					
Boom Type	1 PC (short)		1 PC		VA	
Stick Length	2.00 m (6'7")	2.30 m (7'7")	2.00 m (6'7")	2.30 m (7'7")	2.00 m (6'7")	2.30 m (7'7")
H110 S	✓	✓	✓	✓	✓	✓
H115 S	✓	✓	✓	✓	✓	✓

CW-20 S Dedicated Coupler

Undercarriage	Front Outriggers; Rear Blade					
Counterweight	2.9 mt					
Boom Type	1 PC (short)		1 PC		VA	
Stick Length	2.00 m (6'7")	2.30 m (7'7")	2.00 m (6'7")	2.30 m (7'7")	2.00 m (6'7")	2.30 m (7'7")
H110 S	✓	✓	✓	✓	✓	✓
H115 S	✓	✓	✓	✓		

CW-20 S Dedicated Coupler *(continued)*

Undercarriage	Front Outriggers; Rear Blade					
Counterweight	3.3 mt					
Boom Type	1 PC (short)		1 PC		VA	
Stick Length	2.00 m (6'7")	2.30 m (7'7")	2.00 m (6'7")	2.30 m (7'7")	2.00 m (6'7")	2.30 m (7'7")
H110 S	✓	✓	✓	✓	✓	✓
H115 S	✓	✓	✓	✓		

CW-20 S Dedicated Coupler *(continued)*

Undercarriage	Rear Blade					
Counterweight	2.9 mt					
Boom Type	1 PC (short)		1 PC		VA	
Stick Length	2.00 m (6'7")	2.30 m (7'7")	2.00 m (6'7")	2.30 m (7'7")	2.00 m (6'7")	2.30 m (7'7")
H110 S	✓	✓	✓	✓	✓	✓
H115 S	✓	✓	✓	✓		

CW-20 S Dedicated Coupler *(continued)*

Undercarriage	Rear Blade					
Counterweight	3.3 mt					
Boom Type	1 PC (short)		1 PC		VA	
Stick Length	2.00 m (6'7")	2.30 m (7'7")	2.00 m (6'7")	2.30 m (7'7")	2.00 m (6'7")	2.30 m (7'7")
H110 S	✓	✓	✓	✓	✓	✓
H115 S	✓	✓	✓	✓		

CW-20 Dedicated Coupler

Undercarriage	Front Outriggers; Rear Blade					
Counterweight	2.9 mt					
Boom Type	1 PC (short)		1 PC		VA	
Stick Length	2.00 m (6'7")	2.30 m (7'7")	2.00 m (6'7")	2.30 m (7'7")	2.00 m (6'7")	2.30 m (7'7")
H110 S	✓	✓	✓	✓	✓	✓
H115 S	✓	✓	✓	✓		✓

(continued on next page)

Hammer Technical Specifications

Matching – Wheeled Excavators (continued)

Match
 * Working Range Front Only
 † Allowed Usage on Machine Less Than 50%
 No Match

M315D2 (continued)

CW-20 Dedicated Coupler (continued)

Undercarriage	Front Outriggers; Rear Blade					
Counterweight	3.3 mt					
Boom Type	1 PC (short)		1 PC		VA	
Stick Length	2.00 m (6'7")	2.30 m (7'7")	2.00 m (6'7")	2.30 m (7'7")	2.00 m (6'7")	2.30 m (7'7")
H110 S	✓	✓	✓	✓	✓	✓
H115 S	✓	✓	✓	✓		✓

CW-20 Dedicated Coupler (continued)

Undercarriage	Rear Blade					
Counterweight	2.9 mt					
Boom Type	1 PC (short)		1 PC		VA	
Stick Length	2.00 m (6'7")	2.30 m (7'7")	2.00 m (6'7")	2.30 m (7'7")	2.00 m (6'7")	2.30 m (7'7")
H110 S	✓	✓	✓	✓	✓	✓
H115 S	✓	✓	✓	✓		✓*

CW-20 Dedicated Coupler (continued)

Undercarriage	Rear Blade					
Counterweight	3.3 mt					
Boom Type	1 PC (short)		1 PC		VA	
Stick Length	2.00 m (6'7")	2.30 m (7'7")	2.00 m (6'7")	2.30 m (7'7")	2.00 m (6'7")	2.30 m (7'7")
H110 S	✓	✓	✓	✓	✓	✓
H115 S	✓	✓	✓	✓		✓

M315F

Pin-on

Undercarriage	Front (parallel) Blade; Rear Outriggers				Front Outriggers; Rear (parallel) Blade			
Counterweight	3.75 mt				3.75 mt			
Boom Type	Offset		VA		Offset		VA	
Stick Length	2.30 m (7'7")	2.45 m (8'0")	2.30 m (7'7")	2.45 m (8'0")	2.30 m (7'7")	2.45 m (8'0")	2.30 m (7'7")	2.45 m (8'0")
H110 S	✓	✓	✓	✓	✓	✓	✓	✓
H115 S	✓	✓	✓	✓	✓	✓	✓	✓

Pin-on (continued)

Undercarriage	Front Outriggers; Rear (radial) Blade				Rear (parallel) Blade			
Counterweight	3.75 mt				3.75 mt			
Boom Type	Offset		VA		Offset		VA	
Stick Length	2.30 m (7'7")	2.45 m (8'0")	2.30 m (7'7")	2.45 m (8'0")	2.30 m (7'7")	2.45 m (8'0")	2.30 m (7'7")	2.45 m (8'0")
H110 S	✓	✓	✓	✓	✓	✓	✓	✓
H115 S	✓	✓	✓	✓	✓	✓	✓	✓

Pin-on (continued)

Undercarriage	Rear (radial) Blade			
Counterweight	3.75 mt			
Boom Type	Offset		VA	
Stick Length	2.30 m (7'7")	2.45 m (8'0")	2.30 m (7'7")	2.45 m (8'0")
H110 S	✓	✓	✓	✓
H115 S	✓	✓	✓	✓

(continued on next page)

Matching – Wheeled Excavators (continued)

Match
 Working Range Front Only
 Allowed Usage on Machine Less Than 50%
 No Match

M315F (continued)

Cat Pin Grabber Coupler

Undercarriage	Front (parallel) Blade; Rear Outriggers				Front Outriggers; Rear (parallel) Blade			
Counterweight	3.75 mt				3.75 mt			
Boom Type	Offset		VA		Offset		VA	
Stick Length	2.30 m (7'7")	2.45 m (8'0")	2.30 m (7'7")	2.45 m (8'0")	2.30 m (7'7")	2.45 m (8'0")	2.30 m (7'7")	2.45 m (8'0")
H110 S	✓	✓	✓	✓	✓	✓	✓	✓
H115 S	✓	✓	✓	✓	✓	✓	✓	✓

Cat Pin Grabber Coupler (continued)

Undercarriage	Front Outriggers; Rear (radial) Blade				Rear (parallel) Blade			
Counterweight	3.75 mt				3.75 mt			
Boom Type	Offset		VA		Offset		VA	
Stick Length	2.30 m (7'7")	2.45 m (8'0")	2.30 m (7'7")	2.45 m (8'0")	2.30 m (7'7")	2.45 m (8'0")	2.30 m (7'7")	2.45 m (8'0")
H110 S	✓	✓	✓	✓	✓	✓	✓	✓
H115 S	✓	✓	✓	✓	✓	✓*	✓	✓

Cat Pin Grabber Coupler (continued)

Undercarriage	Rear (radial) Blade			
Counterweight	3.75 mt			
Boom Type	Offset		VA	
Stick Length	2.30 m (7'7")	2.45 m (8'0")	2.30 m (7'7")	2.45 m (8'0")
H110 S	✓	✓	✓	✓
H115 S	✓*	✓*	✓	✓

CW-20 S Dedicated Coupler

Undercarriage	Front (parallel) Blade; Rear Outriggers				Front Outriggers; Rear (parallel) Blade			
Counterweight	3.75 mt				3.75 mt			
Boom Type	Offset		VA		Offset		VA	
Stick Length	2.30 m (7'7")	2.45 m (8'0")	2.30 m (7'7")	2.45 m (8'0")	2.30 m (7'7")	2.45 m (8'0")	2.30 m (7'7")	2.45 m (8'0")
H110 S	✓	✓	✓	✓	✓	✓	✓	✓
H115 S	✓	✓	✓	✓	✓	✓	✓	✓

CW-20 S Dedicated Coupler (continued)

Undercarriage	Front Outriggers; Rear (radial) Blade				Rear (parallel) Blade			
Counterweight	3.75 mt				3.75 mt			
Boom Type	Offset		VA		Offset		VA	
Stick Length	2.30 m (7'7")	2.45 m (8'0")	2.30 m (7'7")	2.45 m (8'0")	2.30 m (7'7")	2.45 m (8'0")	2.30 m (7'7")	2.45 m (8'0")
H110 S	✓	✓	✓	✓	✓	✓	✓	✓
H115 S	✓	✓	✓	✓	✓	✓	✓	✓

CW-20 S Dedicated Coupler (continued)

Undercarriage	Rear (radial) Blade			
Counterweight	3.75 mt			
Boom Type	Offset		VA	
Stick Length	2.30 m (7'7")	2.45 m (8'0")	2.30 m (7'7")	2.45 m (8'0")
H110 S	✓	✓	✓	✓
H115 S	✓	✓	✓	✓

(continued on next page)

Hammer Technical Specifications

Matching – Wheeled Excavators (continued)

Match
 Working Range Front Only
 Allowed Usage on Machine Less Than 50%
 No Match

M315F (continued)

CW-20 Dedicated Coupler

Undercarriage	Front (parallel) Blade; Rear Outriggers				Front Outriggers; Rear (parallel) Blade			
Counterweight	3.75 mt				3.75 mt			
Boom Type	Offset		VA		Offset		VA	
Stick Length	2.30 m (7'7")	2.45 m (8'0")	2.30 m (7'7")	2.45 m (8'0")	2.30 m (7'7")	2.45 m (8'0")	2.30 m (7'7")	2.45 m (8'0")
H110 S	✓	✓	✓	✓	✓	✓	✓	✓
H115 S	✓	✓	✓	✓	✓	✓	✓	✓

CW-20 Dedicated Coupler (continued)

Undercarriage	Front Outriggers; Rear (radial) Blade				Rear (parallel) Blade			
Counterweight	3.75 mt				3.75 mt			
Boom Type	Offset		VA		Offset		VA	
Stick Length	2.30 m (7'7")	2.45 m (8'0")	2.30 m (7'7")	2.45 m (8'0")	2.30 m (7'7")	2.45 m (8'0")	2.30 m (7'7")	2.45 m (8'0")
H110 S	✓	✓	✓	✓	✓	✓	✓	✓
H115 S	✓	✓	✓	✓	✓	✓	✓	✓

CW-20 Dedicated Coupler (continued)

Undercarriage	Rear (radial) Blade			
Counterweight	3.75 mt			
Boom Type	Offset		VA	
Stick Length	2.30 m (7'7")	2.45 m (8'0")	2.30 m (7'7")	2.45 m (8'0")
H110 S	✓	✓	✓	✓
H115 S	✓	✓	✓	✓

M315

Pin-on

Undercarriage	Front and Rear Outriggers			
Counterweight	2.6 mt			
Boom Type	1 PC		1 PC (short)	
Stick Length	2.20 m (7'3")	2.50 m (8'2")	2.20 m (7'3")	2.50 m (8'2")
H110 S	✓	✓	✓	✓
H115 S	✓	✓	✓	✓

Pin-on (continued)

Undercarriage	Front and Rear Outriggers					
Counterweight	3.1 mt				4.0 mt	
Boom Type	1 PC		1 PC (short)		VA	
Stick Length	2.20 m (7'3")	2.50 m (8'2")	2.20 m (7'3")	2.50 m (8'2")	2.20 m (7'3")	2.50 m (8'2")
H110 S	✓	✓	✓	✓	✓	✓
H115 S	✓	✓	✓	✓	✓	✓

Pin-on (continued)

Undercarriage	Front Blade; Rear Outriggers			
Counterweight	2.6 mt			
Boom Type	1 PC		1 PC (short)	
Stick Length	2.20 m (7'3")	2.50 m (8'2")	2.20 m (7'3")	2.50 m (8'2")
H110 S	✓	✓	✓	✓
H115 S	✓	✓	✓	✓

(continued on next page)

Matching – Wheeled Excavators (continued)

Match
 Working Range Front Only
 Allowed Usage on Machine Less Than 50%
 No Match

M315 (continued)

Pin-on (continued)

Undercarriage	Front Blade; Rear Outriggers					
Counterweight	3.1 mt				4.0 mt	
Boom Type	1 PC		1 PC (short)		VA	
Stick Length	2.20 m (7'3")	2.50 m (8'2")	2.20 m (7'3")	2.50 m (8'2")	2.20 m (7'3")	2.50 m (8'2")
H110 S	✓	✓	✓	✓	✓	✓
H115 S	✓	✓	✓	✓	✓	✓

Pin-on (continued)

Undercarriage	Front Outriggers; Rear Blade							
Counterweight	2.6 mt				3.1 mt			
Boom Type	1 PC		1 PC (short)		1 PC		1 PC (short)	
Stick Length	2.20 m (7'3")	2.50 m (8'2")	2.20 m (7'3")	2.50 m (8'2")	2.20 m (7'3")	2.50 m (8'2")	2.20 m (7'3")	2.50 m (8'2")
H110 S	✓	✓	✓	✓	✓	✓	✓	✓
H115 S	✓	✓	✓	✓	✓	✓	✓	✓

Pin-on (continued)

Undercarriage	Rear Blade							
Counterweight	2.6 mt				3.1 mt			
Boom Type	1 PC		1 PC (short)		1 PC		1 PC (short)	
Stick Length	2.20 m (7'3")	2.50 m (8'2")	2.20 m (7'3")	2.50 m (8'2")	2.20 m (7'3")	2.50 m (8'2")	2.20 m (7'3")	2.50 m (8'2")
H110 S	✓	✓	✓	✓	✓	✓	✓	✓
H115 S	✓	✓	✓	✓	✓	✓	✓	✓

Pin-on (continued)

Undercarriage	Rear Blade	
Counterweight	4.0 mt	
Boom Type	VA	
Stick Length	2.20 m (7'3")	2.50 m (8'2")
H110 S	✓	✓
H115 S	✓	✓

Cat Pin Grabber Coupler

Undercarriage	Front and Rear Outriggers					
Counterweight	2.6 mt		3.1 mt		4.0 mt	
Boom Type	1 PC		1 PC		VA	
Stick Length	2.20 m (7'3")	2.50 m (8'2")	2.20 m (7'3")	2.50 m (8'2")	2.20 m (7'3")	2.50 m (8'2")
H110 S	✓	✓	✓	✓	✓	✓
H115 S	✓	✓	✓	✓	✓	

Cat Pin Grabber Coupler (continued)

Undercarriage	Front Blade; Rear Outriggers					
Counterweight	2.6 mt		3.1 mt		4.0 mt	
Boom Type	1 PC		1 PC		VA	
Stick Length	2.20 m (7'3")	2.50 m (8'2")	2.20 m (7'3")	2.50 m (8'2")	2.20 m (7'3")	2.50 m (8'2")
H110 S	✓	✓	✓	✓	✓	✓
H115 S	✓	✓	✓	✓	✓	

(continued on next page)

Hammer Technical Specifications

Matching – Wheeled Excavators *(continued)*

Match
 Working Range Front Only
 Allowed Usage on Machine Less Than 50%
 No Match

M315 *(continued)*

Cat Pin Grabber Coupler *(continued)*

Undercarriage	Front Outriggers; Rear Blade					
Counterweight	2.6 mt		3.1 mt		4.0 mt	
Boom Type	1 PC		1 PC		VA	
Stick Length	2.20 m (7'3")	2.50 m (8'2")	2.20 m (7'3")	2.50 m (8'2")	2.20 m (7'3")	2.50 m (8'2")
H110 S	✓	✓	✓	✓	✓	✓
H115 S	✓	✓	✓	✓	✓	

Cat Pin Grabber Coupler *(continued)*

Undercarriage	Rear Blade					
Counterweight	2.6 mt		3.1 mt		4.0 mt	
Boom Type	1 PC		1 PC		VA	
Stick Length	2.20 m (7'3")	2.50 m (8'2")	2.20 m (7'3")	2.50 m (8'2")	2.20 m (7'3")	2.50 m (8'2")
H110 S	✓	✓	✓	✓	✓	✓
H115 S	✓	✓	✓	✓	✓	

CW-20 S Dedicated Coupler

Undercarriage	Front and Rear Outriggers					
Counterweight	2.6 mt		3.1 mt		4.0 mt	
Boom Type	1 PC		1 PC		VA	
Stick Length	2.20 m (7'3")	2.50 m (8'2")	2.20 m (7'3")	2.50 m (8'2")	2.20 m (7'3")	
H110 S	✓	✓	✓	✓	✓	
H115 S	✓	✓	✓	✓		

CW-20 S Dedicated Coupler *(continued)*

Undercarriage	Front Blade; Rear Outriggers					
Counterweight	2.6 mt		3.1 mt		4.0 mt	
Boom Type	1 PC		1 PC		VA	
Stick Length	2.20 m (7'3")	2.50 m (8'2")	2.20 m (7'3")	2.50 m (8'2")	2.20 m (7'3")	
H110 S	✓	✓	✓	✓	✓	
H115 S	✓	✓	✓	✓		

CW-20 S Dedicated Coupler *(continued)*

Undercarriage	Front Outriggers; Rear Blade					
Counterweight	2.6 mt		3.1 mt		4.0 mt	
Boom Type	1 PC		1 PC		VA	
Stick Length	2.20 m (7'3")	2.50 m (8'2")	2.20 m (7'3")	2.50 m (8'2")	2.20 m (7'3")	
H110 S	✓	✓	✓	✓	✓	
H115 S	✓	✓	✓	✓		

CW-20 S Dedicated Coupler *(continued)*

Undercarriage	Rear Blade					
Counterweight	2.6 mt		3.1 mt		4.0 mt	
Boom Type	1 PC		1 PC		VA	
Stick Length	2.20 m (7'3")	2.50 m (8'2")	2.20 m (7'3")	2.50 m (8'2")	2.20 m (7'3")	
H110 S	✓	✓	✓	✓	✓	
H115 S	✓	✓	✓	✓		

(continued on next page)

Matching – Wheeled Excavators (continued)

Match
 Working Range Front Only
 Allowed Usage on Machine Less Than 50%
 No Match

M315 (continued)

CW-20 Dedicated Coupler

Undercarriage	Front and Rear Outriggers					
Counterweight	2.6 mt		3.1 mt		4.0 mt	
Boom Type	1 PC		1 PC		VA	
Stick Length	2.20 m (7'3")	2.50 m (8'2")	2.20 m (7'3")	2.50 m (8'2")	2.20 m (7'3")	2.50 m (8'2")
H110 S	✓	✓	✓	✓	✓	✓
H115 S	✓	✓	✓	✓		

CW-20 Dedicated Coupler (continued)

Undercarriage	Front Blade; Rear Outriggers					
Counterweight	2.6 mt		3.1 mt		4.0 mt	
Boom Type	1 PC		1 PC		VA	
Stick Length	2.20 m (7'3")	2.50 m (8'2")	2.20 m (7'3")	2.50 m (8'2")	2.20 m (7'3")	2.50 m (8'2")
H110 S	✓	✓	✓	✓	✓	✓
H115 S	✓	✓	✓	✓		

CW-20 Dedicated Coupler (continued)

Undercarriage	Front Outriggers; Rear Blade					
Counterweight	2.6 mt		3.1 mt		4.0 mt	
Boom Type	1 PC		1 PC		VA	
Stick Length	2.20 m (7'3")	2.50 m (8'2")	2.20 m (7'3")	2.50 m (8'2")	2.20 m (7'3")	2.50 m (8'2")
H110 S	✓	✓	✓	✓	✓	✓
H115 S	✓	✓	✓	✓		

CW-20 Dedicated Coupler (continued)

Undercarriage	Rear Blade					
Counterweight	2.6 mt		3.1 mt		4.0 mt	
Boom Type	1 PC		1 PC		VA	
Stick Length	2.20 m (7'3")	2.50 m (8'2")	2.20 m (7'3")	2.50 m (8'2")	2.20 m (7'3")	2.50 m (8'2")
H110 S	✓	✓	✓	✓	✓	✓
H115 S	✓	✓	✓	✓		

S60 Dedicated Coupler

Undercarriage	Front and Rear Outriggers		Front Blade; Rear Outriggers		Front Outriggers; Rear Blade		Rear Blade	
Counterweight	4.0 mt		4.0 mt		4.0 mt		4.0 mt	
Boom Type	VA		VA		VA		VA	
Stick Length	2.20 m (7'3")	2.50 m (8'2")	2.20 m (7'3")	2.50 m (8'2")	2.20 m (7'3")	2.50 m (8'2")	2.20 m (7'3")	2.50 m (8'2")
H110 S	✓	✓	✓	✓	✓	✓	✓	✓
H115 S	✓		✓		✓		✓	

HCS60 Dedicated Coupler

Undercarriage	Front and Rear Outriggers		Front Blade; Rear Outriggers		Front Outriggers; Rear Blade		Rear Blade	
Counterweight	4.0 mt		4.0 mt		4.0 mt		4.0 mt	
Boom Type	VA		VA		VA		VA	
Stick Length	2.20 m (7'3")	2.50 m (8'2")	2.20 m (7'3")	2.50 m (8'2")	2.20 m (7'3")	2.50 m (8'2")	2.20 m (7'3")	2.50 m (8'2")
H110 S	✓	✓	✓	✓	✓	✓	✓	✓
H115 S	✓	✓	✓	✓	✓	✓	✓	✓

(continued on next page)

Hammer Technical Specifications

Matching – Wheeled Excavators (continued)

Match
 Working Range Front Only
 Allowed Usage on Machine Less Than 50%
 No Match

M315 (continued)

HCS65 Dedicated Coupler

Undercarriage	Front and Rear Outriggers		Front Blade; Rear Outriggers		Front Outriggers; Rear Blade		Rear Blade	
Counterweight	4.0 mt		4.0 mt		4.0 mt		4.0 mt	
Boom Type	VA		VA		VA		VA	
Stick Length	2.20 m (7'3")	2.50 m (8'2")	2.20 m (7'3")	2.50 m (8'2")	2.20 m (7'3")	2.50 m (8'2")	2.20 m (7'3")	2.50 m (8'2")
H110 S	✓	✓	✓	✓	✓	✓	✓	✓
H115 S	✓	✓	✓	✓	✓	✓	✓	✓

M316F

Pin-on

Undercarriage	Front (parallel) Blade; Rear Outriggers					
Counterweight	3.2 mt					
Boom Type	1 PC			VA		
Stick Length	2.10 m (6'11")	2.40 m (7'10")	2.60 m (8'6")	2.10 m (6'11")	2.40 m (7'10")	2.60 m (8'6")
H110 S	✓	✓	✓	✓	✓	✓
H115 S	✓	✓	✓	✓	✓	✓
H120 S	✓	✓	✓	✓	✓	✓

Pin-on (continued)

Undercarriage	Front (parallel) Blade; Rear Outriggers					
Counterweight	3.7 mt					
Boom Type	1 PC			VA		
Stick Length	2.10 m (6'11")	2.40 m (7'10")	2.60 m (8'6")	2.10 m (6'11")	2.40 m (7'10")	2.60 m (8'6")
H110 S	✓	✓	✓	✓	✓	✓
H115 S	✓	✓	✓	✓	✓	✓
H120 S	✓	✓	✓	✓	✓	✓

Pin-on (continued)

Undercarriage	Front and Rear Outriggers					
Counterweight	3.2 mt					
Boom Type	1 PC			VA		
Stick Length	2.10 m (6'11")	2.40 m (7'10")	2.60 m (8'6")	2.10 m (6'11")	2.40 m (7'10")	2.60 m (8'6")
H110 S	✓	✓	✓	✓	✓	✓
H115 S	✓	✓	✓	✓	✓	✓
H120 S	✓	✓	✓	✓	✓	✓

Pin-on (continued)

Undercarriage	Front and Rear Outriggers					
Counterweight	3.7 mt					
Boom Type	1 PC			VA		
Stick Length	2.10 m (6'11")	2.40 m (7'10")	2.60 m (8'6")	2.10 m (6'11")	2.40 m (7'10")	2.60 m (8'6")
H110 S	✓	✓	✓	✓	✓	✓
H115 S	✓	✓	✓	✓	✓	✓
H120 S	✓	✓	✓	✓	✓	✓

(continued on next page)

Hammer Technical Specifications

Matching – Wheeled Excavators (continued)

Match
 * Working Range Front Only
 † Allowed Usage on Machine Less Than 50%
 No Match

M316F (continued)

Pin-on (continued)

Undercarriage	Front Blade; Rear Outriggers					
Counterweight	3.2 mt					
Boom Type	1 PC			VA		
Stick Length	2.10 m (6'11")	2.40 m (7'10")	2.60 m (8'6")	2.10 m (6'11")	2.40 m (7'10")	2.60 m (8'6")
H110 S	✓	✓	✓	✓	✓	✓
H115 S	✓	✓	✓	✓	✓	✓
H120 S	✓	✓	✓	✓	✓	✓

Pin-on (continued)

Undercarriage	Front Blade; Rear Outriggers					
Counterweight	3.7 mt					
Boom Type	1 PC			VA		
Stick Length	2.10 m (6'11")	2.40 m (7'10")	2.60 m (8'6")	2.10 m (6'11")	2.40 m (7'10")	2.60 m (8'6")
H110 S	✓	✓	✓	✓	✓	✓
H115 S	✓	✓	✓	✓	✓	✓
H120 S	✓	✓	✓	✓	✓	✓

Pin-on (continued)

Undercarriage	Rear (parallel) Blade					
Counterweight	3.2 mt					
Boom Type	1 PC			VA		
Stick Length	2.10 m (6'11")	2.40 m (7'10")	2.60 m (8'6")	2.10 m (6'11")	2.40 m (7'10")	2.60 m (8'6")
H110 S	✓	✓	✓	✓	✓	✓
H115 S	✓	✓	✓	✓	✓	✓
H120 S	✓	✓	✓*	✓*		

Pin-on (continued)

Undercarriage	Rear (parallel) Blade					
Counterweight	3.7 mt					
Boom Type	1 PC			VA		
Stick Length	2.10 m (6'11")	2.40 m (7'10")	2.60 m (8'6")	2.10 m (6'11")	2.40 m (7'10")	2.60 m (8'6")
H110 S	✓	✓	✓	✓	✓	✓
H115 S	✓	✓	✓	✓	✓	✓
H120 S	✓	✓	✓	✓	✓	✓*

Pin-on (continued)

Undercarriage	Rear Blade					
Counterweight	3.2 mt					
Boom Type	1 PC			VA		
Stick Length	2.10 m (6'11")	2.40 m (7'10")	2.60 m (8'6")	2.10 m (6'11")	2.40 m (7'10")	2.60 m (8'6")
H110 S	✓	✓	✓	✓	✓	✓
H115 S	✓	✓	✓	✓	✓	✓
H120 S	✓	✓	✓*	✓*		

(continued on next page)

Hammer Technical Specifications

Matching – Wheeled Excavators (continued)

Match
 Working Range Front Only
 Allowed Usage on Machine Less Than 50%
 No Match

M316F (continued)

Pin-on (continued)

Undercarriage	Rear Blade					
Counterweight	3.7 mt					
Boom Type	1 PC			VA		
Stick Length	2.10 m (6'11")	2.40 m (7'10")	2.60 m (8'6")	2.10 m (6'11")	2.40 m (7'10")	2.60 m (8'6")
H110 S	✓	✓	✓	✓	✓	✓
H115 S	✓	✓	✓	✓	✓	✓
H120 S	✓	✓	✓	✓	✓	✓*

Cat Pin Grabber Coupler

Undercarriage	Front (parallel) Blade; Rear Outriggers					
Counterweight	3.2 mt					
Boom Type	1 PC			VA		
Stick Length	2.10 m (6'11")	2.40 m (7'10")	2.60 m (8'6")	2.10 m (6'11")	2.40 m (7'10")	2.60 m (8'6")
H110 S	✓	✓	✓	✓	✓	✓
H115 S	✓	✓	✓	✓	✓	✓
H120 S	✓	✓	✓	✓	✓	✓

Cat Pin Grabber Coupler (continued)

Undercarriage	Front (parallel) Blade; Rear Outriggers					
Counterweight	3.7 mt					
Boom Type	1 PC			VA		
Stick Length	2.10 m (6'11")	2.40 m (7'10")	2.60 m (8'6")	2.10 m (6'11")	2.40 m (7'10")	2.60 m (8'6")
H110 S	✓	✓	✓	✓	✓	✓
H115 S	✓	✓	✓	✓	✓	✓
H120 S	✓	✓	✓	✓	✓	✓

Cat Pin Grabber Coupler (continued)

Undercarriage	Front and Rear Outriggers					
Counterweight	3.2 mt					
Boom Type	1 PC			VA		
Stick Length	2.10 m (6'11")	2.40 m (7'10")	2.60 m (8'6")	2.10 m (6'11")	2.40 m (7'10")	2.60 m (8'6")
H110 S	✓	✓	✓	✓	✓	✓
H115 S	✓	✓	✓	✓	✓	✓
H120 S	✓	✓	✓	✓	✓	✓

Cat Pin Grabber Coupler (continued)

Undercarriage	Front and Rear Outriggers					
Counterweight	3.7 mt					
Boom Type	1 PC			VA		
Stick Length	2.10 m (6'11")	2.40 m (7'10")	2.60 m (8'6")	2.10 m (6'11")	2.40 m (7'10")	2.60 m (8'6")
H110 S	✓	✓	✓	✓	✓	✓
H115 S	✓	✓	✓	✓	✓	✓
H120 S	✓	✓	✓	✓	✓	✓

(continued on next page)

Matching – Wheeled Excavators (continued)

Match
 Working Range Front Only
 Allowed Usage on Machine Less Than 50%
 No Match

M316F (continued)

Cat Pin Grabber Coupler (continued)

Undercarriage	Front Blade; Rear Outriggers					
Counterweight	3.2 mt					
Boom Type	1 PC			VA		
Stick Length	2.10 m (6'11")	2.40 m (7'10")	2.60 m (8'6")	2.10 m (6'11")	2.40 m (7'10")	2.60 m (8'6")
H110 S	✓	✓	✓	✓	✓	✓
H115 S	✓	✓	✓	✓	✓	✓
H120 S	✓	✓	✓	✓	✓	✓

Cat Pin Grabber Coupler (continued)

Undercarriage	Front Blade; Rear Outriggers					
Counterweight	3.7 mt					
Boom Type	1 PC			VA		
Stick Length	2.10 m (6'11")	2.40 m (7'10")	2.60 m (8'6")	2.10 m (6'11")	2.40 m (7'10")	2.60 m (8'6")
H110 S	✓	✓	✓	✓	✓	✓
H115 S	✓	✓	✓	✓	✓	✓
H120 S	✓	✓	✓	✓	✓	✓

Cat Pin Grabber Coupler (continued)

Undercarriage	Rear (parallel) Blade					
Counterweight	3.2 mt					
Boom Type	1 PC			VA		
Stick Length	2.10 m (6'11")	2.40 m (7'10")	2.60 m (8'6")	2.10 m (6'11")	2.40 m (7'10")	2.60 m (8'6")
H110 S	✓	✓	✓	✓	✓	✓
H115 S	✓	✓	✓	✓	✓	✓*
H120 S						

Cat Pin Grabber Coupler (continued)

Undercarriage	Rear (parallel) Blade					
Counterweight	3.7 mt					
Boom Type	1 PC			VA		
Stick Length	2.10 m (6'11")	2.40 m (7'10")	2.60 m (8'6")	2.10 m (6'11")	2.40 m (7'10")	2.60 m (8'6")
H110 S	✓	✓	✓	✓	✓	✓
H115 S	✓	✓	✓	✓	✓	✓
H120 S	✓*					

Cat Pin Grabber Coupler (continued)

Undercarriage	Rear Blade					
Counterweight	3.2 mt					
Boom Type	1 PC			VA		
Stick Length	2.10 m (6'11")	2.40 m (7'10")	2.60 m (8'6")	2.10 m (6'11")	2.40 m (7'10")	2.60 m (8'6")
H110 S	✓	✓	✓	✓	✓	✓
H115 S	✓	✓	✓	✓	✓*	✓*
H120 S						

(continued on next page)

Hammer Technical Specifications

Matching – Wheeled Excavators *(continued)*

Match
 * Working Range Front Only
 † Allowed Usage on Machine Less Than 50%
 No Match

M316F *(continued)*

Cat Pin Grabber Coupler *(continued)*

Undercarriage	Rear Blade					
Counterweight	3.7 mt					
Boom Type	1 PC			VA		
Stick Length	2.10 m (6'11")	2.40 m (7'10")	2.60 m (8'6")	2.10 m (6'11")	2.40 m (7'10")	2.60 m (8'6")
H110 S	✓	✓	✓	✓	✓	✓
H115 S	✓	✓	✓	✓	✓	✓
H120 S	✓*					

CW-20 S Dedicated Coupler

Undercarriage	Front (parallel) Blade; Rear Outriggers					
Counterweight	3.2 mt					
Boom Type	1 PC			VA		
Stick Length	2.10 m (6'11")	2.40 m (7'10")	2.60 m (8'6")	2.10 m (6'11")	2.40 m (7'10")	2.60 m (8'6")
H110 S	✓	✓	✓	✓	✓	✓
H115 S	✓	✓	✓	✓	✓	✓
H120 S	✓	✓	✓			

CW-20 S Dedicated Coupler *(continued)*

Undercarriage	Front (parallel) Blade; Rear Outriggers					
Counterweight	3.7 mt					
Boom Type	1 PC			VA		
Stick Length	2.10 m (6'11")	2.40 m (7'10")	2.60 m (8'6")	2.10 m (6'11")	2.40 m (7'10")	2.60 m (8'6")
H110 S	✓	✓	✓	✓	✓	✓
H115 S	✓	✓	✓	✓	✓	✓
H120 S	✓	✓	✓			

CW-20 S Dedicated Coupler *(continued)*

Undercarriage	Front and Rear Outriggers					
Counterweight	3.2 mt					
Boom Type	1 PC			VA		
Stick Length	2.10 m (6'11")	2.40 m (7'10")	2.60 m (8'6")	2.10 m (6'11")	2.40 m (7'10")	2.60 m (8'6")
H110 S	✓	✓	✓	✓	✓	✓
H115 S	✓	✓	✓	✓	✓	✓
H120 S	✓	✓	✓			

CW-20 S Dedicated Coupler *(continued)*

Undercarriage	Front and Rear Outriggers					
Counterweight	3.7 mt					
Boom Type	1 PC			VA		
Stick Length	2.10 m (6'11")	2.40 m (7'10")	2.60 m (8'6")	2.10 m (6'11")	2.40 m (7'10")	2.60 m (8'6")
H110 S	✓	✓	✓	✓	✓	✓
H115 S	✓	✓	✓	✓	✓	✓
H120 S	✓	✓	✓			

(continued on next page)

Matching – Wheeled Excavators (continued)

Match
 * Working Range Front Only
 † Allowed Usage on Machine Less Than 50%
 No Match

M316F (continued)

CW-20 S Dedicated Coupler (continued)

Undercarriage	Front Blade; Rear Outriggers					
Counterweight	3.2 mt					
Boom Type	1 PC			VA		
Stick Length	2.10 m (6'11")	2.40 m (7'10")	2.60 m (8'6")	2.10 m (6'11")	2.40 m (7'10")	2.60 m (8'6")
H110 S	✓	✓	✓	✓	✓	✓
H115 S	✓	✓	✓	✓	✓	✓
H120 S	✓	✓	✓			

CW-20 S Dedicated Coupler (continued)

Undercarriage	Front Blade; Rear Outriggers					
Counterweight	3.7 mt					
Boom Type	1 PC			VA		
Stick Length	2.10 m (6'11")	2.40 m (7'10")	2.60 m (8'6")	2.10 m (6'11")	2.40 m (7'10")	2.60 m (8'6")
H110 S	✓	✓	✓	✓	✓	✓
H115 S	✓	✓	✓	✓	✓	✓
H120 S	✓	✓	✓			

CW-20 S Dedicated Coupler (continued)

Undercarriage	Rear (parallel) Blade					
Counterweight	3.2 mt					
Boom Type	1 PC			VA		
Stick Length	2.10 m (6'11")	2.40 m (7'10")	2.60 m (8'6")	2.10 m (6'11")	2.40 m (7'10")	2.60 m (8'6")
H110 S	✓	✓	✓	✓	✓	✓
H115 S	✓	✓	✓	✓	✓	✓
H120 S						

CW-20 S Dedicated Coupler (continued)

Undercarriage	Rear (parallel) Blade					
Counterweight	3.7 mt					
Boom Type	1 PC			VA		
Stick Length	2.10 m (6'11")	2.40 m (7'10")	2.60 m (8'6")	2.10 m (6'11")	2.40 m (7'10")	2.60 m (8'6")
H110 S	✓	✓	✓	✓	✓	✓
H115 S	✓	✓	✓	✓	✓	✓
H120 S	✓	✓*				

CW-20 S Dedicated Coupler (continued)

Undercarriage	Rear Blade					
Counterweight	3.2 mt					
Boom Type	1 PC			VA		
Stick Length	2.10 m (6'11")	2.40 m (7'10")	2.60 m (8'6")	2.10 m (6'11")	2.40 m (7'10")	2.60 m (8'6")
H110 S	✓	✓	✓	✓	✓	✓
H115 S	✓	✓	✓	✓	✓	✓
H120 S						

(continued on next page)

Hammer Technical Specifications

Matching – Wheeled Excavators *(continued)*

Match
 Working Range Front Only
 Allowed Usage on Machine Less Than 50%
 No Match

M316F *(continued)*

CW-20 S Dedicated Coupler *(continued)*

Undercarriage	Rear Blade					
Counterweight	3.7 mt					
Boom Type	1 PC			VA		
Stick Length	2.10 m (6'11")	2.40 m (7'10")	2.60 m (8'6")	2.10 m (6'11")	2.40 m (7'10")	2.60 m (8'6")
H110 S	✓	✓	✓	✓	✓	✓
H115 S	✓	✓	✓	✓	✓	✓
H120 S	✓	✓*				

CW-20 Dedicated Coupler

Undercarriage	Front (parallel) Blade; Rear Outriggers					
Counterweight	3.2 mt					
Boom Type	1 PC			VA		
Stick Length	2.10 m (6'11")	2.40 m (7'10")	2.60 m (8'6")	2.10 m (6'11")	2.40 m (7'10")	2.60 m (8'6")
H110 S	✓	✓	✓	✓	✓	✓
H115 GC	✓	✓	✓	✓	✓	✓
H115 S	✓	✓	✓	✓	✓	✓
H120 S	✓	✓	✓			

CW-20 Dedicated Coupler *(continued)*

Undercarriage	Front (parallel) Blade; Rear Outriggers					
Counterweight	3.7 mt					
Boom Type	1 PC			VA		
Stick Length	2.10 m (6'11")	2.40 m (7'10")	2.60 m (8'6")	2.10 m (6'11")	2.40 m (7'10")	2.60 m (8'6")
H110 S	✓	✓	✓	✓	✓	✓
H115 GC	✓	✓	✓	✓	✓	✓
H115 S	✓	✓	✓	✓	✓	✓
H120 S	✓	✓	✓			

CW-20 Dedicated Coupler *(continued)*

Undercarriage	Front and Rear Outriggers					
Counterweight	3.2 mt					
Boom Type	1 PC			VA		
Stick Length	2.10 m (6'11")	2.40 m (7'10")	2.60 m (8'6")	2.10 m (6'11")	2.40 m (7'10")	2.60 m (8'6")
H110 S	✓	✓	✓	✓	✓	✓
H115 GC	✓	✓	✓	✓	✓	✓
H115 S	✓	✓	✓	✓	✓	✓
H120 S	✓	✓	✓			

CW-20 Dedicated Coupler *(continued)*

Undercarriage	Front and Rear Outriggers					
Counterweight	3.7 mt					
Boom Type	1 PC			VA		
Stick Length	2.10 m (6'11")	2.40 m (7'10")	2.60 m (8'6")	2.10 m (6'11")	2.40 m (7'10")	2.60 m (8'6")
H110 S	✓	✓	✓	✓	✓	✓
H115 GC	✓	✓	✓	✓	✓	✓
H115 S	✓	✓	✓	✓	✓	✓
H120 S	✓	✓	✓			

(continued on next page)

Matching – Wheeled Excavators (continued)

Match
 Working Range Front Only
 Allowed Usage on Machine Less Than 50%
 No Match

M316F (continued)

CW-20 Dedicated Coupler (continued)

Undercarriage	Front Blade; Rear Outriggers					
Counterweight	3.2 mt					
Boom Type	1 PC			VA		
Stick Length	2.10 m (6'11")	2.40 m (7'10")	2.60 m (8'6")	2.10 m (6'11")	2.40 m (7'10")	2.60 m (8'6")
H110 S	✓	✓	✓	✓	✓	✓
H115 GC	✓	✓	✓	✓	✓	✓
H115 S	✓	✓	✓	✓	✓	✓
H120 S	✓	✓	✓			

CW-20 Dedicated Coupler (continued)

Undercarriage	Front Blade; Rear Outriggers					
Counterweight	3.7 mt					
Boom Type	1 PC			VA		
Stick Length	2.10 m (6'11")	2.40 m (7'10")	2.60 m (8'6")	2.10 m (6'11")	2.40 m (7'10")	2.60 m (8'6")
H110 S	✓	✓	✓	✓	✓	✓
H115 GC	✓	✓	✓	✓	✓	✓
H115 S	✓	✓	✓	✓	✓	✓
H120 S	✓	✓	✓			

CW-20 Dedicated Coupler (continued)

Undercarriage	Rear (parallel) Blade					
Counterweight	3.2 mt					
Boom Type	1 PC			VA		
Stick Length	2.10 m (6'11")	2.40 m (7'10")	2.60 m (8'6")	2.10 m (6'11")	2.40 m (7'10")	2.60 m (8'6")
H110 S	✓	✓	✓	✓	✓	✓
H115 GC	✓	✓	✓*	✓*	✓*	
H115 S	✓	✓	✓	✓	✓	✓
H120 S						

CW-20 Dedicated Coupler (continued)

Undercarriage	Rear (parallel) Blade					
Counterweight	3.7 mt					
Boom Type	1 PC			VA		
Stick Length	2.10 m (6'11")	2.40 m (7'10")	2.60 m (8'6")	2.10 m (6'11")	2.40 m (7'10")	2.60 m (8'6")
H110 S	✓	✓	✓	✓	✓	✓
H115 GC	✓	✓	✓	✓	✓	✓
H115 S	✓	✓	✓	✓	✓	✓
H120 S	✓	✓*				

CW-20 Dedicated Coupler (continued)

Undercarriage	Rear Blade					
Counterweight	3.2 mt					
Boom Type	1 PC			VA		
Stick Length	2.10 m (6'11")	2.40 m (7'10")	2.60 m (8'6")	2.10 m (6'11")	2.40 m (7'10")	2.60 m (8'6")
H110 S	✓	✓	✓	✓	✓	✓
H115 GC	✓	✓	✓*	✓*		
H115 S	✓	✓	✓	✓	✓	✓*
H120 S						

(continued on next page)

Hammer Technical Specifications

Matching – Wheeled Excavators (continued)

Match
 * Working Range Front Only
 † Allowed Usage on Machine Less Than 50%
 No Match

M316F (continued)

CW-20 Dedicated Coupler (continued)

Undercarriage	Rear Blade					
Counterweight	3.7 mt					
Boom Type	1 PC			VA		
Stick Length	2.10 m (6'11")	2.40 m (7'10")	2.60 m (8'6")	2.10 m (6'11")	2.40 m (7'10")	2.60 m (8'6")
H110 S	✓	✓	✓	✓	✓	✓
H115 GC	✓	✓	✓	✓	✓	✓*
H115 S	✓	✓	✓	✓	✓	✓
H120 S	✓	✓*				

M316

Pin-on

Undercarriage	Front and Rear Outriggers			Front Blade; Rear Outriggers		
Counterweight	2.6 mt	3.3 mt		2.6 mt	3.3 mt	
Boom Type	VA	VA		VA	VA	
Stick Length	2.50 m (8'2")	2.20 m (7'3")	2.50 m (8'2")	2.50 m (8'2")	2.20 m (7'3")	2.50 m (8'2")
H110 S	✓	✓	✓	✓	✓	✓
H115 S	✓	✓	✓	✓	✓	✓
H120 S	✓	✓	✓	✓	✓	✓

Pin-on (continued)

Undercarriage	Front Outriggers; Rear Blade			Rear Blade		
Counterweight	2.6 mt	3.3 mt		2.6 mt	3.3 mt	
Boom Type	VA	VA		VA	VA	
Stick Length	2.50 m (8'2")	2.20 m (7'3")	2.50 m (8'2")	2.50 m (8'2")	2.20 m (7'3")	2.50 m (8'2")
H110 S	✓	✓	✓	✓	✓	✓
H115 S	✓	✓	✓	✓	✓	✓
H120 S	✓	✓	✓		✓	✓*

Cat Pin Grabber Coupler

Undercarriage	Front and Rear Outriggers			Front Blade; Rear Outriggers		
Counterweight	2.6 mt	3.3 mt		2.6 mt	3.3 mt	
Boom Type	VA	VA		VA	VA	
Stick Length	2.50 m (8'2")	2.20 m (7'3")	2.50 m (8'2")	2.50 m (8'2")	2.20 m (7'3")	2.50 m (8'2")
H110 S	✓	✓	✓	✓	✓	✓
H115 S	✓	✓	✓	✓	✓	✓
H120 S		✓			✓	

Cat Pin Grabber Coupler (continued)

Undercarriage	Front Outriggers; Rear Blade			Rear Blade		
Counterweight	2.6 mt	3.3 mt		2.6 mt	3.3 mt	
Boom Type	VA	VA		VA	VA	
Stick Length	2.50 m (8'2")	2.20 m (7'3")	2.50 m (8'2")	2.50 m (8'2")	2.20 m (7'3")	2.50 m (8'2")
H110 S	✓	✓	✓	✓*	✓	✓
H115 S	✓	✓	✓		✓	✓
H120 S		✓				

(continued on next page)

Matching – Wheeled Excavators (continued)

Match
 * Working Range Front Only
 † Allowed Usage on Machine Less Than 50%
 No Match

M316 (continued)

CW-30 S Dedicated Coupler

Undercarriage	Front and Rear Outriggers		Front Blade; Rear Outriggers		Front Outriggers; Rear Blade		Rear Blade	
Counterweight	3.3 mt		3.3 mt		3.3 mt		3.3 mt	
Boom Type	VA		VA		VA		VA	
Stick Length	2.20 m (7'3")	2.50 m (8'2")	2.20 m (7'3")	2.50 m (8'2")	2.20 m (7'3")	2.50 m (8'2")	2.20 m (7'3")	2.50 m (8'2")
H110 S	✓	✓	✓	✓	✓	✓	✓	✓
H115 S	✓	✓	✓	✓	✓	✓	✓	✓

CW-30 Dedicated Coupler

Undercarriage	Front and Rear Outriggers		Front Blade; Rear Outriggers		Front Outriggers; Rear Blade		Rear Blade	
Counterweight	3.3 mt		3.3 mt		3.3 mt		3.3 mt	
Boom Type	VA		VA		VA		VA	
Stick Length	2.20 m (7'3")	2.50 m (8'2")	2.20 m (7'3")	2.50 m (8'2")	2.20 m (7'3")	2.50 m (8'2")	2.20 m (7'3")	2.50 m (8'2")
H110 S	✓	✓	✓	✓	✓	✓	✓	✓
H115 S	✓	✓	✓	✓	✓	✓	✓	✓
H120 S	✓		✓		✓			

S60 Dedicated Coupler

Undercarriage	Front and Rear Outriggers		Front Blade; Rear Outriggers		Front Outriggers; Rear Blade		Rear Blade	
Counterweight	3.3 mt		3.3 mt		3.3 mt		3.3 mt	
Boom Type	VA		VA		VA		VA	
Stick Length	2.20 m (7'3")	2.50 m (8'2")	2.20 m (7'3")	2.50 m (8'2")	2.20 m (7'3")	2.50 m (8'2")	2.20 m (7'3")	2.50 m (8'2")
H110 S	✓	✓	✓	✓	✓	✓	✓	✓
H115 S	✓	✓	✓	✓	✓	✓	✓	✓

HCS60 Dedicated Coupler

Undercarriage	Front and Rear Outriggers		Front Blade; Rear Outriggers		Front Outriggers; Rear Blade		Rear Blade	
Counterweight	3.3 mt		3.3 mt		3.3 mt		3.3 mt	
Boom Type	VA		VA		VA		VA	
Stick Length	2.20 m (7'3")	2.50 m (8'2")	2.20 m (7'3")	2.50 m (8'2")	2.20 m (7'3")	2.50 m (8'2")	2.20 m (7'3")	2.50 m (8'2")
H110 S	✓	✓	✓	✓	✓	✓	✓	✓
H115 S	✓	✓	✓	✓	✓	✓	✓	✓
H120 S	✓	✓	✓	✓	✓	✓		

HCS65 Dedicated Coupler

Undercarriage	Front and Rear Outriggers		Front Blade; Rear Outriggers		Front Outriggers; Rear Blade		Rear Blade	
Counterweight	3.3 mt		3.3 mt		3.3 mt		3.3 mt	
Boom Type	VA		VA		VA		VA	
Stick Length	2.20 m (7'3")	2.50 m (8'2")	2.20 m (7'3")	2.50 m (8'2")	2.20 m (7'3")	2.50 m (8'2")	2.20 m (7'3")	2.50 m (8'2")
H110 S	✓	✓	✓	✓	✓	✓	✓	✓
H115 S	✓	✓	✓	✓	✓	✓	✓	✓
H120 S	✓	✓	✓	✓	✓	✓		

(continued on next page)

Hammer Technical Specifications

Matching – Wheeled Excavators (continued)

Match
 * Working Range Front Only
 † Allowed Usage on Machine Less Than 50%
 No Match

M316 (continued)

Tilt-Rotator TRS14 with CW30 S Dedicated Coupler

Undercarriage	Front and Rear Outriggers		Front Blade; Rear Outriggers		Front Outriggers; Rear Blade	
Counterweight	3.3 mt		3.3 mt		3.3 mt	
Boom Type	VA		VA		VA	
Stick Length	2.20 m (7'3")	2.50 m (8'2")	2.20 m (7'3")	2.50 m (8'2")	2.20 m (7'3")	2.50 m (8'2")
H110 S	✓	✓	✓	✓	✓	✓

Tilt-Rotator TRS14 with CW30 Dedicated Coupler

Undercarriage	Front and Rear Outriggers	Front Blade; Rear Outriggers	Front Outriggers; Rear Blade
Counterweight	3.3 mt	3.3 mt	3.3 mt
Boom Type	VA	VA	VA
Stick Length	2.20 m (7'3")	2.20 m (7'3")	2.20 m (7'3")
H110 S	✓	✓	✓

Tilt-Rotator TRS14 with S60 Dedicated Coupler

Undercarriage	Front and Rear Outriggers		Front Blade; Rear Outriggers			
Counterweight	2.6 mt	3.3 mt	2.6 mt	3.3 mt		
Boom Type	VA	VA	VA	VA		
Stick Length	2.50 m (8'2")	2.20 m (7'3")	2.50 m (8'2")	2.50 m (8'2")	2.20 m (7'3")	2.50 m (8'2")
H110 S	✓	✓	✓	✓	✓	✓
H115 S	✓	✓	✓	✓	✓	✓

Tilt-Rotator TRS14 with S60 Dedicated Coupler (continued)

Undercarriage	Front Outriggers; Rear Blade		Rear Blade		
Counterweight	2.6 mt	3.3 mt	3.3 mt		
Boom Type	VA	VA	VA		
Stick Length	2.50 m (8'2")	2.20 m (7'3")	2.50 m (8'2")	2.20 m (7'3")	2.50 m (8'2")
H110 S	✓	✓	✓	✓	✓
H115 S	✓	✓	✓	✓	✓

S60 – Tilt-Rotator TRS14 – S60

Undercarriage	Front and Rear Outriggers		Front Blade; Rear Outriggers		Front Outriggers; Rear Blade	
Counterweight	3.3 mt		3.3 mt		3.3 mt	
Boom Type	VA		VA		VA	
Stick Length	2.20 m (7'3")	2.50 m (8'2")	2.20 m (7'3")	2.50 m (8'2")	2.20 m (7'3")	2.50 m (8'2")
H110 S	✓	✓	✓	✓	✓	✓
H115 S	✓		✓		✓	

HCS60 – Tilt-Rotator TRS14 – HCS60

Undercarriage	Front and Rear Outriggers		Front Blade; Rear Outriggers		Front Outriggers; Rear Blade	
Counterweight	3.3 mt		3.3 mt		3.3 mt	
Boom Type	VA		VA		VA	
Stick Length	2.20 m (7'3")	2.50 m (8'2")	2.20 m (7'3")	2.50 m (8'2")	2.20 m (7'3")	2.50 m (8'2")
H110 S	✓	✓	✓	✓	✓	✓
H115 S	✓		✓		✓	

(continued on next page)

Matching – Wheeled Excavators (continued)

Match
 Working Range Front Only
 Allowed Usage on Machine Less Than 50%
 No Match

M316 (continued)

Tilt-Rotator TRS14 with HCS65 Dedicated Coupler

Undercarriage	Front and Rear Outriggers		Front Blade; Rear Outriggers		Front Outriggers; Rear Blade	
Counterweight	3.3 mt		3.3 mt		3.3 mt	
Boom Type	VA		VA		VA	
Stick Length	2.20 m (7'3")	2.50 m (8'2")	2.20 m (7'3")	2.50 m (8'2")	2.20 m (7'3")	2.50 m (8'2")
H110 S	✓	✓	✓	✓	✓	✓
H115 S	✓		✓		✓	

HCS65 – Tilt-Rotator TRS14 – HCS65

Undercarriage	Front and Rear Outriggers	Front Blade; Rear Outriggers	Front Outriggers; Rear Blade
Counterweight	3.3 mt	3.3 mt	3.3 mt
Boom Type	VA	VA	VA
Stick Length	2.20 m (7'3")	2.20 m (7'3")	2.20 m (7'3")
H110 S	✓	✓	✓

M317D2

Pin-on

Undercarriage	Front Outriggers; Rear Blade							
Counterweight	3.5 mt				3.9 mt			
Boom Type	1 PC		VA		1 PC		VA	
Stick Length	2.40 m (7'10")	2.60 m (8'6")	2.40 m (7'10")	2.60 m (8'6")	2.40 m (7'10")	2.60 m (8'6")	2.40 m (7'10")	2.60 m (8'6")
H110 S	✓	✓	✓	✓	✓	✓	✓	✓
H115 S	✓	✓	✓	✓	✓	✓	✓	✓
H120 S	✓	✓	✓	✓	✓	✓	✓	✓

Pin-on (continued)

Undercarriage	Rear Blade							
Counterweight	3.5 mt				3.9 mt			
Boom Type	1 PC		VA		1 PC		VA	
Stick Length	2.40 m (7'10")	2.60 m (8'6")	2.40 m (7'10")	2.60 m (8'6")	2.40 m (7'10")	2.60 m (8'6")	2.40 m (7'10")	2.60 m (8'6")
H110 S	✓	✓	✓	✓	✓	✓	✓	✓
H115 S	✓	✓	✓	✓	✓	✓	✓	✓
H120 S	✓	✓*	✓*		✓	✓	✓	✓

Cat Pin Grabber Coupler

Undercarriage	Front Outriggers; Rear Blade							
Counterweight	3.5 mt				3.9 mt			
Boom Type	1 PC		VA		1 PC		VA	
Stick Length	2.40 m (7'10")	2.60 m (8'6")	2.40 m (7'10")	2.60 m (8'6")	2.40 m (7'10")	2.60 m (8'6")	2.40 m (7'10")	2.60 m (8'6")
H110 S	✓	✓	✓	✓	✓	✓	✓	✓
H115 GC	✓	✓	✓	✓	✓	✓	✓	✓
H115 GC S	✓	✓	✓	✓	✓	✓	✓	✓
H115 S	✓	✓	✓	✓	✓	✓	✓	✓
H120 S	✓	✓	✓	✓	✓	✓	✓	✓

(continued on next page)

Hammer Technical Specifications

Matching – Wheeled Excavators (continued)

Match
 Working Range Front Only
 Allowed Usage on Machine Less Than 50%
 No Match

M317D2 (continued)

Cat Pin Grabber Coupler (continued)

Undercarriage	Rear Blade							
Counterweight	3.5 mt				3.9 mt			
Boom Type	1 PC		VA		1 PC		VA	
Stick Length	2.40 m (7'10")	2.60 m (8'6")	2.40 m (7'10")	2.60 m (8'6")	2.40 m (7'10")	2.60 m (8'6")	2.40 m (7'10")	2.60 m (8'6")
H110 S	✓	✓	✓	✓	✓	✓	✓	✓
H115 GC	✓*				✓	✓	✓*	✓*
H115 GC S	✓	✓*	✓*		✓	✓	✓	✓*
H115 S	✓	✓	✓	✓	✓	✓	✓	✓
H120 S								

CW-20 S Dedicated Coupler

Undercarriage	Front Outriggers; Rear Blade							
Counterweight	3.5 mt				3.9 mt			
Boom Type	1 PC		VA		1 PC		VA	
Stick Length	2.40 m (7'10")	2.60 m (8'6")	2.40 m (7'10")	2.60 m (8'6")	2.40 m (7'10")	2.60 m (8'6")	2.40 m (7'10")	2.60 m (8'6")
H110 S	✓	✓	✓	✓	✓	✓	✓	✓
H115 S	✓	✓	✓	✓	✓	✓	✓	✓
H120 S	✓	✓			✓	✓		

CW-20 S Dedicated Coupler (continued)

Undercarriage	Rear Blade							
Counterweight	3.5 mt				3.9 mt			
Boom Type	1 PC		VA		1 PC		VA	
Stick Length	2.40 m (7'10")	2.60 m (8'6")	2.40 m (7'10")	2.60 m (8'6")	2.40 m (7'10")	2.60 m (8'6")	2.40 m (7'10")	2.60 m (8'6")
H110 S	✓	✓	✓	✓	✓	✓	✓	✓
H115 S	✓	✓	✓	✓	✓	✓	✓	✓
H120 S					✓*			

CW-20 Dedicated Coupler

Undercarriage	Front Outriggers; Rear Blade							
Counterweight	3.5 mt				3.9 mt			
Boom Type	1 PC		VA		1 PC		VA	
Stick Length	2.40 m (7'10")	2.60 m (8'6")	2.40 m (7'10")	2.60 m (8'6")	2.40 m (7'10")	2.60 m (8'6")	2.40 m (7'10")	2.60 m (8'6")
H110 S	✓	✓	✓	✓	✓	✓	✓	✓
H115 S	✓	✓	✓	✓	✓	✓	✓	✓
H120 S	✓	✓			✓	✓		

CW-20 Dedicated Coupler (continued)

Undercarriage	Rear Blade							
Counterweight	3.5 mt				3.9 mt			
Boom Type	1 PC		VA		1 PC		VA	
Stick Length	2.40 m (7'10")	2.60 m (8'6")	2.40 m (7'10")	2.60 m (8'6")	2.40 m (7'10")	2.60 m (8'6")	2.40 m (7'10")	2.60 m (8'6")
H110 S	✓	✓	✓	✓	✓	✓	✓	✓
H115 S	✓	✓	✓	✓	✓	✓	✓	✓
H120 S					✓*			

(continued on next page)

Matching – Wheeled Excavators (continued)

Match
 Working Range Front Only
 Allowed Usage on Machine Less Than 50%
 No Match

M317F

Pin-on

Undercarriage	Front (parallel) Blade; Rear Outriggers			Front Outriggers; Rear (parallel) Blade		
Counterweight	4.3 mt			4.3 mt		
Boom Type	Offset	VA		Offset	VA	
Stick Length	2.45 m (8'0")	2.45 m (8'0")	2.60 m (8'6")	2.45 m (8'0")	2.45 m (8'0")	2.60 m (8'6")
H110 S	✓	✓	✓	✓	✓	✓
H115 S	✓	✓	✓	✓	✓	✓
H120 S	✓	✓		✓	✓	

Pin-on (continued)

Undercarriage	Rear (parallel) Blade			Wide Axle – Rear (parallel) Blade		
Counterweight	4.3 mt			4.3 mt		
Boom Type	Offset	VA		Offset	VA	
Stick Length	2.45 m (8'0")	2.45 m (8'0")	2.60 m (8'6")	2.45 m (8'0")	2.45 m (8'0")	2.60 m (8'6")
H110 S	✓	✓	✓	✓	✓	✓
H115 S	✓	✓	✓	✓	✓	✓
H120 S	✓	✓		✓	✓	

Cat Pin Grabber Coupler

Undercarriage	Front (parallel) Blade; Rear Outriggers			Front Outriggers; Rear (parallel) Blade		
Counterweight	4.3 mt			4.3 mt		
Boom Type	Offset	VA		Offset	VA	
Stick Length	2.45 m (8'0")	2.45 m (8'0")	2.60 m (8'6")	2.45 m (8'0")	2.45 m (8'0")	2.60 m (8'6")
H110 S	✓	✓	✓	✓	✓	✓
H115 S	✓	✓	✓	✓	✓	✓

Cat Pin Grabber Coupler (continued)

Undercarriage	Rear (parallel) Blade			Wide Axle – Rear (parallel) Blade		
Counterweight	4.3 mt			4.3 mt		
Boom Type	Offset	VA		Offset	VA	
Stick Length	2.45 m (8'0")	2.45 m (8'0")	2.60 m (8'6")	2.45 m (8'0")	2.45 m (8'0")	2.60 m (8'6")
H110 S	✓	✓	✓	✓	✓	✓
H115 S	✓	✓	✓	✓	✓	✓

CW-20 S Dedicated Coupler

Undercarriage	Front (parallel) Blade; Rear Outriggers			Front Outriggers; Rear (parallel) Blade		
Counterweight	4.3 mt			4.3 mt		
Boom Type	Offset	VA		Offset	VA	
Stick Length	2.45 m (8'0")	2.45 m (8'0")	2.60 m (8'6")	2.45 m (8'0")	2.45 m (8'0")	2.60 m (8'6")
H110 S	✓	✓	✓	✓	✓	✓
H115 S	✓	✓	✓	✓	✓	✓

CW-20 S Dedicated Coupler (continued)

Undercarriage	Rear (parallel) Blade			Wide Axle – Rear (parallel) Blade		
Counterweight	4.3 mt			4.3 mt		
Boom Type	Offset	VA		Offset	VA	
Stick Length	2.45 m (8'0")	2.45 m (8'0")	2.60 m (8'6")	2.45 m (8'0")	2.45 m (8'0")	2.60 m (8'6")
H110 S	✓	✓	✓	✓	✓	✓
H115 S	✓	✓	✓	✓	✓	✓

(continued on next page)

Hammer Technical Specifications

Matching – Wheeled Excavators (continued)

Match
 Working Range Front Only
 Allowed Usage on Machine Less Than 50%
 No Match

M317F (continued)

CW-20 Dedicated Coupler

Undercarriage	Front (parallel) Blade; Rear Outriggers			Front Outriggers; Rear (parallel) Blade		
Counterweight	4.3 mt			4.3 mt		
Boom Type	Offset	VA		Offset	VA	
Stick Length	2.45 m (8'0")	2.45 m (8'0")	2.60 m (8'6")	2.45 m (8'0")	2.45 m (8'0")	2.60 m (8'6")
H110 S	✓	✓	✓	✓	✓	✓
H115 S	✓	✓	✓	✓	✓	✓

CW-20 Dedicated Coupler (continued)

Undercarriage	Rear (parallel) Blade			Wide Axle – Rear (parallel) Blade		
Counterweight	4.3 mt			4.3 mt		
Boom Type	Offset	VA		Offset	VA	
Stick Length	2.45 m (8'0")	2.45 m (8'0")	2.60 m (8'6")	2.45 m (8'0")	2.45 m (8'0")	2.60 m (8'6")
H110 S	✓	✓	✓	✓	✓	✓
H115 S	✓	✓	✓	✓	✓	✓

M317

Pin-on

Undercarriage	Front and Rear Outriggers		Front Blade; Rear Outriggers		Front Outriggers; Rear Blade		Rear Blade	
Counterweight	4.3 mt		4.3 mt		4.3 mt		4.3 mt	
Boom Type	VA		VA		VA		VA	
Stick Length	2.20 m (7'3")	2.50 m (8'2")	2.20 m (7'3")	2.50 m (8'2")	2.20 m (7'3")	2.50 m (8'2")	2.20 m (7'3")	2.50 m (8'2")
H110 S	✓	✓	✓	✓	✓	✓	✓	✓
H115 S	✓	✓	✓	✓	✓	✓	✓	✓
H120 S		✓		✓		✓		✓*

Cat Pin Grabber Coupler

Undercarriage	Front and Rear Outriggers		Front Blade; Rear Outriggers		Front Outriggers; Rear Blade		Rear Blade	
Counterweight	4.3 mt		4.3 mt		4.3 mt		4.3 mt	
Boom Type	VA		VA		VA		VA	
Stick Length	2.20 m (7'3")	2.50 m (8'2")	2.20 m (7'3")	2.50 m (8'2")	2.20 m (7'3")	2.50 m (8'2")	2.20 m (7'3")	2.50 m (8'2")
H110 S	✓	✓	✓	✓	✓	✓	✓	✓
H115 S	✓	✓	✓	✓	✓	✓	✓	✓

CW-30 S Dedicated Coupler

Undercarriage	Front and Rear Outriggers		Front Blade; Rear Outriggers		Front Outriggers; Rear Blade		Rear Blade	
Counterweight	4.3 mt		4.3 mt		4.3 mt		4.3 mt	
Boom Type	VA		VA		VA		VA	
Stick Length	2.20 m (7'3")	2.50 m (8'2")	2.20 m (7'3")	2.50 m (8'2")	2.20 m (7'3")	2.50 m (8'2")	2.20 m (7'3")	2.50 m (8'2")
H110 S	✓	✓	✓	✓	✓	✓	✓	✓
H115 S	✓	✓	✓	✓	✓	✓	✓	✓

CW-30 Dedicated Coupler

Undercarriage	Front and Rear Outriggers		Front Blade; Rear Outriggers		Front Outriggers; Rear Blade		Rear Blade	
Counterweight	4.3 mt		4.3 mt		4.3 mt		4.3 mt	
Boom Type	VA		VA		VA		VA	
Stick Length	2.20 m (7'3")	2.50 m (8'2")	2.20 m (7'3")	2.50 m (8'2")	2.20 m (7'3")	2.50 m (8'2")	2.20 m (7'3")	2.50 m (8'2")
H110 S	✓	✓	✓	✓	✓	✓	✓	✓
H115 S	✓	✓	✓	✓	✓	✓	✓	✓

(continued on next page)

Matching – Wheeled Excavators (continued)

Match
 Working Range Front Only
 Allowed Usage on Machine Less Than 50%
 No Match

M317 (continued)

HCS60 Dedicated Coupler

Undercarriage	Front and Rear Outriggers		Front Blade; Rear Outriggers		Front Outriggers; Rear Blade		Rear Blade	
Counterweight	4.3 mt		4.3 mt		4.3 mt		4.3 mt	
Boom Type	VA		VA		VA		VA	
Stick Length	2.20 m (7'3")	2.50 m (8'2")	2.20 m (7'3")	2.50 m (8'2")	2.20 m (7'3")	2.50 m (8'2")	2.20 m (7'3")	2.50 m (8'2")
H110 S	✓	✓	✓	✓	✓	✓	✓	✓
H115 S	✓	✓	✓	✓	✓	✓	✓	✓

HCS65 Dedicated Coupler

Undercarriage	Front and Rear Outriggers		Front Blade; Rear Outriggers		Front Outriggers; Rear Blade		Rear Blade	
Counterweight	4.3 mt		4.3 mt		4.3 mt		4.3 mt	
Boom Type	VA		VA		VA		VA	
Stick Length	2.20 m (7'3")	2.50 m (8'2")	2.20 m (7'3")	2.50 m (8'2")	2.20 m (7'3")	2.50 m (8'2")	2.20 m (7'3")	2.50 m (8'2")
H110 S	✓	✓	✓	✓	✓	✓	✓	✓
H115 S	✓	✓	✓	✓	✓	✓	✓	✓

Tilt-Rotator TRS14 with S60 Dedicated Coupler

Undercarriage	Front and Rear Outriggers	Front Blade; Rear Outriggers	Front Outriggers; Rear Blade	Rear Blade
Counterweight	4.3 mt	4.3 mt	4.3 mt	4.3 mt
Boom Type	VA	VA	VA	VA
Stick Length	2.50 m (8'2")	2.50 m (8'2")	2.50 m (8'2")	2.50 m (8'2")
H110 S	✓	✓	✓	✓

M318F

Pin-on

Undercarriage	Front and Rear Outriggers					
Counterweight	3.4 mt					
Boom Type	1 PC			VA		
Stick Length	2.10 m (6'11")	2.40 m (7'10")	2.60 m (8'6")	2.10 m (6'11")	2.40 m (7'10")	2.60 m (8'6")
H110 S	✓	✓	✓	✓	✓	✓
H115 S	✓	✓	✓	✓	✓	✓
H120 S	✓	✓	✓	✓	✓	✓

Pin-on (continued)

Undercarriage	Front and Rear Outriggers					
Counterweight	3.9 mt					
Boom Type	1 PC			VA		
Stick Length	2.10 m (6'11")	2.40 m (7'10")	2.60 m (8'6")	2.10 m (6'11")	2.40 m (7'10")	2.60 m (8'6")
H110 S	✓	✓	✓	✓	✓	✓
H115 S	✓	✓	✓	✓	✓	✓
H120 S	✓	✓	✓	✓	✓	✓

(continued on next page)

Hammer Technical Specifications

Matching – Wheeled Excavators (continued)

Match
 Working Range Front Only
 Allowed Usage on Machine Less Than 50%
 No Match

M318F (continued)

Pin-on (continued)

Undercarriage	Front Outriggers; Rear Blade (Wide U/C)					
Counterweight	3.4 mt					
Boom Type	1 PC			VA		
Stick Length	2.10 m (6'11")	2.40 m (7'10")	2.60 m (8'6")	2.10 m (6'11")	2.40 m (7'10")	2.60 m (8'6")
H110 S	✓	✓	✓	✓	✓	✓
H115 S	✓	✓	✓	✓	✓	✓
H120 S	✓	✓	✓	✓	✓	✓

Pin-on (continued)

Undercarriage	Front Outriggers; Rear Blade (Wide U/C)					
Counterweight	3.9 mt					
Boom Type	1 PC			VA		
Stick Length	2.10 m (6'11")	2.40 m (7'10")	2.60 m (8'6")	2.10 m (6'11")	2.40 m (7'10")	2.60 m (8'6")
H110 S	✓	✓	✓	✓	✓	✓
H115 S	✓	✓	✓	✓	✓	✓
H120 S	✓	✓	✓	✓	✓	✓

Pin-on (continued)

Undercarriage	Front Outriggers; Rear Blade					
Counterweight	3.4 mt					
Boom Type	1 PC			VA		
Stick Length	2.10 m (6'11")	2.40 m (7'10")	2.60 m (8'6")	2.10 m (6'11")	2.40 m (7'10")	2.60 m (8'6")
H110 S	✓	✓	✓	✓	✓	✓
H115 S	✓	✓	✓	✓	✓	✓
H120 S	✓	✓	✓	✓	✓	✓

Pin-on (continued)

Undercarriage	Front Outriggers; Rear Blade					
Counterweight	3.9 mt					
Boom Type	1 PC			VA		
Stick Length	2.10 m (6'11")	2.40 m (7'10")	2.60 m (8'6")	2.10 m (6'11")	2.40 m (7'10")	2.60 m (8'6")
H110 S	✓	✓	✓	✓	✓	✓
H115 S	✓	✓	✓	✓	✓	✓
H120 S	✓	✓	✓	✓	✓	✓

Pin-on (continued)

Undercarriage	Rear Blade					
Counterweight	3.4 mt					
Boom Type	1 PC			VA		
Stick Length	2.10 m (6'11")	2.40 m (7'10")	2.60 m (8'6")	2.10 m (6'11")	2.40 m (7'10")	2.60 m (8'6")
H110 S	✓	✓	✓	✓	✓	✓
H115 S	✓	✓	✓	✓	✓	✓
H120 S		✓	✓	✓	✓	✓*

(continued on next page)

Matching – Wheeled Excavators *(continued)*

Match
 * Working Range Front Only
 † Allowed Usage on Machine Less Than 50%
 No Match

M318F *(continued)*

Pin-on *(continued)*

Undercarriage	Rear Blade					
Counterweight	3.9 mt					
Boom Type	1 PC			VA		
Stick Length	2.10 m (6'11")	2.40 m (7'10")	2.60 m (8'6")	2.10 m (6'11")	2.40 m (7'10")	2.60 m (8'6")
H110 S	✓	✓	✓	✓	✓	✓
H115 S	✓	✓	✓	✓	✓	✓
H120 S	✓	✓	✓	✓	✓	✓

Pin-on *(continued)*

Undercarriage	Rear Blade (Wide U/C)					
Counterweight	3.4 mt					
Boom Type	1 PC			VA		
Stick Length	2.10 m (6'11")	2.40 m (7'10")	2.60 m (8'6")	2.10 m (6'11")	2.40 m (7'10")	2.60 m (8'6")
H110 S	✓	✓	✓	✓	✓	✓
H115 S	✓	✓	✓	✓	✓	✓
H120 S	✓	✓	✓	✓	✓	✓

Pin-on *(continued)*

Undercarriage	Rear Blade (Wide U/C)					
Counterweight	3.9 mt					
Boom Type	1 PC			VA		
Stick Length	2.10 m (6'11")	2.40 m (7'10")	2.60 m (8'6")	2.10 m (6'11")	2.40 m (7'10")	2.60 m (8'6")
H110 S	✓	✓	✓	✓	✓	✓
H115 S	✓	✓	✓	✓	✓	✓
H120 S	✓	✓	✓	✓	✓	✓

Cat Pin Grabber Coupler

Undercarriage	Front and Rear Outriggers					
Counterweight	3.4 mt					
Boom Type	1 PC			VA		
Stick Length	2.10 m (6'11")	2.40 m (7'10")	2.60 m (8'6")	2.10 m (6'11")	2.40 m (7'10")	2.60 m (8'6")
H110 S	✓	✓	✓	✓	✓	✓
H115 S	✓	✓	✓	✓	✓	✓
H120 S	✓	✓	✓	✓	✓	✓

Cat Pin Grabber Coupler *(continued)*

Undercarriage	Front and Rear Outriggers					
Counterweight	3.9 mt					
Boom Type	1 PC			VA		
Stick Length	2.10 m (6'11")	2.40 m (7'10")	2.60 m (8'6")	2.10 m (6'11")	2.40 m (7'10")	2.60 m (8'6")
H110 S	✓	✓	✓	✓	✓	✓
H115 S	✓	✓	✓	✓	✓	✓
H120 S	✓	✓	✓	✓	✓	✓

(continued on next page)

Hammer Technical Specifications

Matching – Wheeled Excavators (continued)

Match
 Working Range Front Only
 Allowed Usage on Machine Less Than 50%
 No Match

M318F (continued)

Cat Pin Grabber Coupler (continued)

Undercarriage	Front Outriggers; Rear Blade (Wide U/C)					
Counterweight	3.4 mt					
Boom Type	1 PC			VA		
Stick Length	2.10 m (6'11")	2.40 m (7'10")	2.60 m (8'6")	2.10 m (6'11")	2.40 m (7'10")	2.60 m (8'6")
H110 S	✓	✓	✓	✓	✓	✓
H115 S	✓	✓	✓	✓	✓	✓
H120 S	✓	✓	✓	✓	✓	✓

Cat Pin Grabber Coupler (continued)

Undercarriage	Front Outriggers; Rear Blade (Wide U/C)					
Counterweight	3.9 mt					
Boom Type	1 PC			VA		
Stick Length	2.10 m (6'11")	2.40 m (7'10")	2.60 m (8'6")	2.10 m (6'11")	2.40 m (7'10")	2.60 m (8'6")
H110 S	✓	✓	✓	✓	✓	✓
H115 S	✓	✓	✓	✓	✓	✓
H120 S	✓	✓	✓	✓	✓	✓

Cat Pin Grabber Coupler (continued)

Undercarriage	Front Outriggers; Rear Blade					
Counterweight	3.4 mt					
Boom Type	1 PC			VA		
Stick Length	2.10 m (6'11")	2.40 m (7'10")	2.60 m (8'6")	2.10 m (6'11")	2.40 m (7'10")	2.60 m (8'6")
H110 S	✓	✓	✓	✓	✓	✓
H115 S	✓	✓	✓	✓	✓	✓
H120 S	✓	✓	✓	✓	✓	✓

Cat Pin Grabber Coupler (continued)

Undercarriage	Front Outriggers; Rear Blade					
Counterweight	3.9 mt					
Boom Type	1 PC			VA		
Stick Length	2.10 m (6'11")	2.40 m (7'10")	2.60 m (8'6")	2.10 m (6'11")	2.40 m (7'10")	2.60 m (8'6")
H110 S	✓	✓	✓	✓	✓	✓
H115 S	✓	✓	✓	✓	✓	✓
H120 S	✓	✓	✓	✓	✓	✓

Cat Pin Grabber Coupler (continued)

Undercarriage	Rear Blade					
Counterweight	3.4 mt					
Boom Type	1 PC			VA		
Stick Length	2.10 m (6'11")	2.40 m (7'10")	2.60 m (8'6")	2.10 m (6'11")	2.40 m (7'10")	2.60 m (8'6")
H110 S	✓	✓	✓	✓	✓	✓
H115 S	✓	✓	✓	✓	✓	✓
H120 S	✓*	✓*				

(continued on next page)

Matching – Wheeled Excavators (continued)

Match
 Working Range Front Only
 Allowed Usage on Machine Less Than 50%
 No Match

M318F (continued)

Cat Pin Grabber Coupler (continued)

Undercarriage	Rear Blade					
Counterweight	3.9 mt					
Boom Type	1 PC			VA		
Stick Length	2.10 m (6'11")	2.40 m (7'10")	2.60 m (8'6")	2.10 m (6'11")	2.40 m (7'10")	2.60 m (8'6")
H110 S	✓	✓	✓	✓	✓	✓
H115 S	✓	✓	✓	✓	✓	✓
H120 S	✓	✓	✓*	✓*	✓*	

Cat Pin Grabber Coupler (continued)

Undercarriage	Rear Blade (Wide U/C)					
Counterweight	3.4 mt					
Boom Type	1 PC			VA		
Stick Length	2.10 m (6'11")	2.40 m (7'10")	2.60 m (8'6")	2.10 m (6'11")	2.40 m (7'10")	2.60 m (8'6")
H110 S	✓	✓	✓	✓	✓	✓
H115 S	✓	✓	✓	✓	✓	✓
H120 S	✓	✓	✓	✓	✓*	

Cat Pin Grabber Coupler (continued)

Undercarriage	Rear Blade (Wide U/C)					
Counterweight	3.9 mt					
Boom Type	1 PC			VA		
Stick Length	2.10 m (6'11")	2.40 m (7'10")	2.60 m (8'6")	2.10 m (6'11")	2.40 m (7'10")	2.60 m (8'6")
H110 S	✓	✓	✓	✓	✓	✓
H115 S	✓	✓	✓	✓	✓	✓
H120 S	✓	✓	✓	✓	✓	✓
	✓	✓	✓	✓	✓	✓

CW-20 S Dedicated Coupler

Undercarriage	Front and Rear Outriggers					
Counterweight	3.4 mt					
Boom Type	1 PC			VA		
Stick Length	2.10 m (6'11")	2.40 m (7'10")	2.60 m (8'6")	2.10 m (6'11")	2.40 m (7'10")	2.60 m (8'6")
H110 S	✓	✓	✓	✓	✓	✓
H115 S	✓	✓	✓	✓	✓	✓
H120 S	✓	✓	✓			

CW-20 S Dedicated Coupler (continued)

Undercarriage	Front and Rear Outriggers					
Counterweight	3.9 mt					
Boom Type	1 PC			VA		
Stick Length	2.10 m (6'11")	2.40 m (7'10")	2.60 m (8'6")	2.10 m (6'11")	2.40 m (7'10")	2.60 m (8'6")
H110 S	✓	✓	✓	✓	✓	✓
H115 S	✓	✓	✓	✓	✓	✓
H120 S	✓	✓	✓			

(continued on next page)

Hammer Technical Specifications

Matching – Wheeled Excavators (continued)

Match
 Working Range Front Only
 Allowed Usage on Machine Less Than 50%
 No Match

M318F (continued)

CW-20 S Dedicated Coupler (continued)

Undercarriage	Front Outriggers; Rear Blade (Wide U/C)					
Counterweight	3.4 mt					
Boom Type	1 PC			VA		
Stick Length	2.10 m (6'11")	2.40 m (7'10")	2.60 m (8'6")	2.10 m (6'11")	2.40 m (7'10")	2.60 m (8'6")
H110 S	✓	✓	✓	✓	✓	✓
H115 S	✓	✓	✓	✓	✓	✓
H120 S	✓	✓	✓			

CW-20 S Dedicated Coupler (continued)

Undercarriage	Front Outriggers; Rear Blade (Wide U/C)					
Counterweight	3.9 mt					
Boom Type	1 PC			VA		
Stick Length	2.10 m (6'11")	2.40 m (7'10")	2.60 m (8'6")	2.10 m (6'11")	2.40 m (7'10")	2.60 m (8'6")
H110 S	✓	✓	✓	✓	✓	✓
H115 S	✓	✓	✓	✓	✓	✓
H120 S	✓	✓	✓			

CW-20 S Dedicated Coupler (continued)

Undercarriage	Front Outriggers; Rear Blade					
Counterweight	3.4 mt					
Boom Type	1 PC			VA		
Stick Length	2.10 m (6'11")	2.40 m (7'10")	2.60 m (8'6")	2.10 m (6'11")	2.40 m (7'10")	2.60 m (8'6")
H110 S	✓	✓	✓	✓	✓	✓
H115 S	✓	✓	✓	✓	✓	✓
H120 S	✓	✓	✓			

CW-20 S Dedicated Coupler (continued)

Undercarriage	Front Outriggers; Rear Blade					
Counterweight	3.9 mt					
Boom Type	1 PC			VA		
Stick Length	2.10 m (6'11")	2.40 m (7'10")	2.60 m (8'6")	2.10 m (6'11")	2.40 m (7'10")	2.60 m (8'6")
H110 S	✓	✓	✓	✓	✓	✓
H115 S	✓	✓	✓	✓	✓	✓
H120 S	✓	✓	✓			

CW-20 S Dedicated Coupler (continued)

Undercarriage	Rear Blade					
Counterweight	3.4 mt					
Boom Type	1 PC			VA		
Stick Length	2.10 m (6'11")	2.40 m (7'10")	2.60 m (8'6")	2.10 m (6'11")	2.40 m (7'10")	2.60 m (8'6")
H110 S	✓	✓	✓	✓	✓	✓
H115 S	✓*	✓	✓	✓	✓	✓
H120 S		✓*	✓*			

(continued on next page)

Matching – Wheeled Excavators *(continued)*

Match
 * Working Range Front Only
 † Allowed Usage on Machine Less Than 50%
 No Match

M318F *(continued)*

CW-20 S Dedicated Coupler *(continued)*

Undercarriage	Rear Blade					
Counterweight	3.9 mt					
Boom Type	1 PC			VA		
Stick Length	2.10 m (6'11")	2.40 m (7'10")	2.60 m (8'6")	2.10 m (6'11")	2.40 m (7'10")	2.60 m (8'6")
H110 S	✓	✓	✓	✓	✓	✓
H115 S	✓	✓	✓	✓	✓	✓
H120 S	✓	✓	✓			

CW-20 S Dedicated Coupler *(continued)*

Undercarriage	Rear Blade (Wide U/C)					
Counterweight	3.4 mt					
Boom Type	1 PC			VA		
Stick Length	2.10 m (6'11")	2.40 m (7'10")	2.60 m (8'6")	2.10 m (6'11")	2.40 m (7'10")	2.60 m (8'6")
H110 S	✓	✓	✓	✓	✓	✓
H115 S	✓	✓	✓	✓	✓	✓
H120 S	✓	✓	✓			

CW-20 S Dedicated Coupler *(continued)*

Undercarriage	Rear Blade (Wide U/C)					
Counterweight	3.9 mt					
Boom Type	1 PC			VA		
Stick Length	2.10 m (6'11")	2.40 m (7'10")	2.60 m (8'6")	2.10 m (6'11")	2.40 m (7'10")	2.60 m (8'6")
H110 S	✓	✓	✓	✓	✓	✓
H115 S	✓	✓	✓	✓	✓	✓
H120 S	✓	✓	✓			

CW-20 Dedicated Coupler

Undercarriage	Front and Rear Outriggers					
Counterweight	3.4 mt					
Boom Type	1 PC			VA		
Stick Length	2.10 m (6'11")	2.40 m (7'10")	2.60 m (8'6")	2.10 m (6'11")	2.40 m (7'10")	2.60 m (8'6")
H110 S	✓	✓	✓	✓	✓	✓
H115 S	✓	✓	✓	✓	✓	✓
H120 S	✓	✓	✓			

CW-20 Dedicated Coupler *(continued)*

Undercarriage	Front and Rear Outriggers					
Counterweight	3.9 mt					
Boom Type	1 PC			VA		
Stick Length	2.10 m (6'11")	2.40 m (7'10")	2.60 m (8'6")	2.10 m (6'11")	2.40 m (7'10")	2.60 m (8'6")
H110 S	✓	✓	✓	✓	✓	✓
H115 S	✓	✓	✓	✓	✓	✓
H120 S	✓	✓	✓			

(continued on next page)

Hammer Technical Specifications

Matching – Wheeled Excavators (continued)

Match
 * Working Range Front Only
 † Allowed Usage on Machine Less Than 50%
 No Match

M318F (continued)

CW-20 Dedicated Coupler (continued)

Undercarriage	Front Outriggers; Rear Blade (Wide U/C)					
Counterweight	3.4 mt					
Boom Type	1 PC			VA		
Stick Length	2.10 m (6'11")	2.40 m (7'10")	2.60 m (8'6")	2.10 m (6'11")	2.40 m (7'10")	2.60 m (8'6")
H110 S	✓	✓	✓	✓	✓	✓
H115 S	✓	✓	✓	✓	✓	✓
H120 S	✓	✓	✓			

CW-20 Dedicated Coupler (continued)

Undercarriage	Front Outriggers; Rear Blade (Wide U/C)					
Counterweight	3.9 mt					
Boom Type	1 PC			VA		
Stick Length	2.10 m (6'11")	2.40 m (7'10")	2.60 m (8'6")	2.10 m (6'11")	2.40 m (7'10")	2.60 m (8'6")
H110 S	✓	✓	✓	✓	✓	✓
H115 S	✓	✓	✓	✓	✓	✓
H120 S	✓	✓	✓			

CW-20 Dedicated Coupler (continued)

Undercarriage	Front Outriggers; Rear Blade					
Counterweight	3.4 mt					
Boom Type	1 PC			VA		
Stick Length	2.10 m (6'11")	2.40 m (7'10")	2.60 m (8'6")	2.10 m (6'11")	2.40 m (7'10")	2.60 m (8'6")
H110 S	✓	✓	✓	✓	✓	✓
H115 S	✓	✓	✓	✓	✓	✓
H120 S	✓	✓	✓			

CW-20 Dedicated Coupler (continued)

Undercarriage	Front Outriggers; Rear Blade					
Counterweight	3.9 mt					
Boom Type	1 PC			VA		
Stick Length	2.10 m (6'11")	2.40 m (7'10")	2.60 m (8'6")	2.10 m (6'11")	2.40 m (7'10")	2.60 m (8'6")
H110 S	✓	✓	✓	✓	✓	✓
H115 S	✓	✓	✓	✓	✓	✓
H120 S	✓	✓	✓			

CW-20 Dedicated Coupler (continued)

Undercarriage	Rear Blade					
Counterweight	3.4 mt					
Boom Type	1 PC			VA		
Stick Length	2.10 m (6'11")	2.40 m (7'10")	2.60 m (8'6")	2.10 m (6'11")	2.40 m (7'10")	2.60 m (8'6")
H110 S	✓	✓	✓	✓	✓	✓
H115 S	✓*	✓	✓	✓	✓	✓
H120 S		✓*				

(continued on next page)

Matching – Wheeled Excavators (continued)

Match
 * Working Range Front Only
 † Allowed Usage on Machine Less Than 50%
 No Match

M318F (continued)

CW-20 Dedicated Coupler (continued)

Undercarriage	Rear Blade					
Counterweight	3.9 mt					
Boom Type	1 PC			VA		
Stick Length	2.10 m (6'11")	2.40 m (7'10")	2.60 m (8'6")	2.10 m (6'11")	2.40 m (7'10")	2.60 m (8'6")
H110 S	✓	✓	✓	✓	✓	✓
H115 S	✓	✓	✓	✓	✓	✓
H120 S	✓	✓	✓			

CW-20 Dedicated Coupler (continued)

Undercarriage	Rear Blade (Wide U/C)					
Counterweight	3.4 mt					
Boom Type	1 PC			VA		
Stick Length	2.10 m (6'11")	2.40 m (7'10")	2.60 m (8'6")	2.10 m (6'11")	2.40 m (7'10")	2.60 m (8'6")
H110 S	✓	✓	✓	✓	✓	✓
H115 S	✓	✓	✓	✓	✓	✓
H120 S	✓	✓	✓			

CW-20 Dedicated Coupler (continued)

Undercarriage	Rear Blade (Wide U/C)					
Counterweight	3.9 mt					
Boom Type	1 PC			VA		
Stick Length	2.10 m (6'11")	2.40 m (7'10")	2.60 m (8'6")	2.10 m (6'11")	2.40 m (7'10")	2.60 m (8'6")
H110 S	✓	✓	✓	✓	✓	✓
H115 S	✓	✓	✓	✓	✓	✓
H120 S	✓	✓	✓			

M318

Pin-on

Undercarriage	Front and Rear Outriggers					
Counterweight	3.7 mt					
Boom Type	1 PC			VA		
Stick Length	2.20 m (7'3")	2.50 m (8'2")	2.90 m (9'6")	2.20 m (7'3")	2.50 m (8'2")	2.90 m (9'6")
H110 S	✓	✓	✓	✓	✓	✓
H115 S	✓	✓	✓	✓	✓	✓
H120 S	✓	✓	✓	✓	✓	✓

Pin-on (continued)

Undercarriage	Front and Rear Outriggers					
Counterweight	4.2 mt					
Boom Type	1 PC			VA		
Stick Length	2.20 m (7'3")	2.50 m (8'2")	2.90 m (9'6")	2.50 m (8'2")	2.90 m (9'6")	
H110 S	✓	✓	✓	✓	✓	
H115 S	✓	✓	✓	✓	✓	
H120 S	✓	✓	✓	✓	✓	

(continued on next page)

Hammer Technical Specifications

Matching – Wheeled Excavators (continued)

Match
 * Working Range Front Only
 † Allowed Usage on Machine Less Than 50%
 No Match

M318 (continued)

Pin-on (continued)

Undercarriage	Front Blade; Rear Outriggers					
Counterweight	3.7 mt					
Boom Type	1 PC			VA		
Stick Length	2.20 m (7'3")	2.50 m (8'2")	2.90 m (9'6")	2.20 m (7'3")	2.50 m (8'2")	2.90 m (9'6")
H110 S	✓	✓	✓	✓	✓	✓
H115 S	✓	✓	✓	✓	✓	✓
H120 S	✓	✓	✓	✓	✓	✓

Pin-on (continued)

Undercarriage	Front Blade; Rear Outriggers					
Counterweight	4.2 mt					
Boom Type	1 PC			VA		
Stick Length	2.20 m (7'3")	2.50 m (8'2")	2.90 m (9'6")	2.20 m (7'3")	2.50 m (8'2")	2.90 m (9'6")
H110 S	✓	✓	✓	✓	✓	✓
H115 S	✓	✓	✓	✓	✓	✓
H120 S	✓	✓	✓	✓	✓	✓

Pin-on (continued)

Undercarriage	Front Outriggers; Rear Blade (Wide U/C)					
Counterweight	3.7 mt					
Boom Type	1 PC			VA		
Stick Length	2.20 m (7'3")	2.50 m (8'2")	2.90 m (9'6")	2.20 m (7'3")	2.50 m (8'2")	2.90 m (9'6")
H110 S	✓	✓	✓	✓	✓	✓
H115 S	✓	✓	✓	✓	✓	✓
H120 S	✓	✓	✓	✓	✓	✓

Pin-on (continued)

Undercarriage	Front Outriggers; Rear Blade (Wide U/C)					
Counterweight	4.2 mt					
Boom Type	1 PC			VA		
Stick Length	2.20 m (7'3")	2.50 m (8'2")	2.90 m (9'6")	2.20 m (7'3")	2.50 m (8'2")	2.90 m (9'6")
H110 S	✓	✓	✓	✓	✓	✓
H115 S	✓	✓	✓	✓	✓	✓
H120 S	✓	✓	✓	✓	✓	✓

Pin-on (continued)

Undercarriage	Front Outriggers; Rear Blade					
Counterweight	3.7 mt					
Boom Type	1 PC			VA		
Stick Length	2.20 m (7'3")	2.50 m (8'2")	2.90 m (9'6")	2.20 m (7'3")	2.50 m (8'2")	2.90 m (9'6")
H110 S	✓	✓	✓	✓	✓	✓
H115 S	✓	✓	✓	✓	✓	✓
H120 S	✓	✓	✓	✓	✓	✓

(continued on next page)

Matching – Wheeled Excavators (continued)

Match
 * Working Range Front Only
 † Allowed Usage on Machine Less Than 50%
 No Match

M318 (continued)

Pin-on (continued)

Undercarriage	Front Outriggers; Rear Blade					
Counterweight	4.2 mt					
Boom Type	1 PC			VA		
Stick Length	2.20 m (7'3")	2.50 m (8'2")	2.90 m (9'6")	2.20 m (7'3")	2.50 m (8'2")	2.90 m (9'6")
H110 S	✓	✓	✓	✓	✓	✓
H115 S	✓	✓	✓	✓	✓	✓
H120 S	✓	✓	✓	✓	✓	✓

Pin-on (continued)

Undercarriage	Rear Blade					
Counterweight	3.7 mt					
Boom Type	1 PC			VA		
Stick Length	2.20 m (7'3")	2.50 m (8'2")	2.90 m (9'6")	2.20 m (7'3")	2.50 m (8'2")	2.90 m (9'6")
H110 S	✓	✓	✓	✓	✓	✓
H115 S	✓	✓	✓	✓	✓	✓
H120 S	✓	✓	✓	✓	✓	✓

Pin-on (continued)

Undercarriage	Rear Blade					
Counterweight	4.2 mt					
Boom Type	1 PC			VA		
Stick Length	2.20 m (7'3")	2.50 m (8'2")	2.90 m (9'6")	2.20 m (7'3")	2.50 m (8'2")	2.90 m (9'6")
H110 S	✓	✓	✓	✓	✓	✓
H115 S	✓	✓	✓	✓	✓	✓
H120 S	✓	✓	✓	✓	✓	✓

Pin-on (continued)

Undercarriage	Rear Blade (Wide U/C)					
Counterweight	3.7 mt					
Boom Type	1 PC			VA		
Stick Length	2.20 m (7'3")	2.50 m (8'2")	2.90 m (9'6")	2.20 m (7'3")	2.50 m (8'2")	2.90 m (9'6")
H110 S	✓	✓	✓	✓	✓	✓
H115 S	✓	✓	✓	✓	✓	✓
H120 S	✓	✓	✓	✓	✓	✓

Pin-on (continued)

Undercarriage	Rear Blade (Wide U/C)					
Counterweight	4.2 mt					
Boom Type	1 PC			VA		
Stick Length	2.20 m (7'3")	2.50 m (8'2")	2.90 m (9'6")	2.20 m (7'3")	2.50 m (8'2")	2.90 m (9'6")
H110 S	✓	✓	✓	✓	✓	✓
H115 S	✓	✓	✓	✓	✓	✓
H120 S	✓	✓	✓	✓	✓	✓

(continued on next page)

Hammer Technical Specifications

Matching – Wheeled Excavators *(continued)*

Match
 Working Range Front Only
 Allowed Usage on Machine Less Than 50%
 No Match

M318 *(continued)*

Cat Pin Grabber Coupler

Undercarriage	Front and Rear Outriggers					
Counterweight	3.7 mt					
Boom Type	1 PC			VA		
Stick Length	2.20 m (7'3")	2.50 m (8'2")	2.90 m (9'6")	2.20 m (7'3")	2.50 m (8'2")	2.90 m (9'6")
H110 S	✓	✓	✓	✓	✓	✓
H115 S	✓	✓	✓	✓	✓	✓
H120 S	✓	✓	✓	✓	✓	✓

Cat Pin Grabber Coupler *(continued)*

Undercarriage	Front and Rear Outriggers					
Counterweight	4.2 mt					
Boom Type	1 PC			VA		
Stick Length	2.20 m (7'3")	2.50 m (8'2")	2.90 m (9'6")	2.20 m (7'3")	2.50 m (8'2")	2.90 m (9'6")
H110 S	✓	✓	✓	✓	✓	✓
H115 S	✓	✓	✓	✓	✓	✓
H120 S	✓	✓	✓	✓	✓	✓

Cat Pin Grabber Coupler *(continued)*

Undercarriage	Front Blade; Rear Outriggers					
Counterweight	3.7 mt					
Boom Type	1 PC			VA		
Stick Length	2.20 m (7'3")	2.50 m (8'2")	2.90 m (9'6")	2.20 m (7'3")	2.50 m (8'2")	2.90 m (9'6")
H110 S	✓	✓	✓	✓	✓	✓
H115 S	✓	✓	✓	✓	✓	✓
H120 S	✓	✓	✓	✓	✓	✓

Cat Pin Grabber Coupler *(continued)*

Undercarriage	Front Blade; Rear Outriggers					
Counterweight	4.2 mt					
Boom Type	1 PC			VA		
Stick Length	2.20 m (7'3")	2.50 m (8'2")	2.90 m (9'6")	2.20 m (7'3")	2.50 m (8'2")	2.90 m (9'6")
H110 S	✓	✓	✓	✓	✓	✓
H115 S	✓	✓	✓	✓	✓	✓
H120 S	✓	✓	✓	✓	✓	✓

Cat Pin Grabber Coupler *(continued)*

Undercarriage	Front Outriggers; Rear Blade (Wide U/C)					
Counterweight	3.7 mt					
Boom Type	1 PC			VA		
Stick Length	2.20 m (7'3")	2.50 m (8'2")	2.90 m (9'6")	2.20 m (7'3")	2.50 m (8'2")	2.90 m (9'6")
H110 S	✓	✓	✓	✓	✓	✓
H115 S	✓	✓	✓	✓	✓	✓
H120 S	✓	✓	✓	✓	✓	✓

(continued on next page)

Matching – Wheeled Excavators *(continued)*

Match
 * Working Range Front Only
 † Allowed Usage on Machine Less Than 50%
 No Match

M318 *(continued)*

Cat Pin Grabber Coupler *(continued)*

Undercarriage	Front Outriggers; Rear Blade (Wide U/C)					
Counterweight	4.2 mt					
Boom Type	1 PC			VA		
Stick Length	2.20 m (7'3")	2.50 m (8'2")	2.90 m (9'6")	2.20 m (7'3")	2.50 m (8'2")	2.90 m (9'6")
H110 S	✓	✓	✓	✓	✓	✓
H115 S	✓	✓	✓	✓	✓	✓
H120 S	✓	✓	✓	✓	✓	✓

Cat Pin Grabber Coupler *(continued)*

Undercarriage	Front Outriggers; Rear Blade					
Counterweight	3.7 mt					
Boom Type	1 PC			VA		
Stick Length	2.20 m (7'3")	2.50 m (8'2")	2.90 m (9'6")	2.20 m (7'3")	2.50 m (8'2")	2.90 m (9'6")
H110 S	✓	✓	✓	✓	✓	✓
H115 S	✓	✓	✓	✓	✓	✓
H120 S	✓	✓	✓	✓	✓	✓

Cat Pin Grabber Coupler *(continued)*

Undercarriage	Front Outriggers; Rear Blade					
Counterweight	4.2 mt					
Boom Type	1 PC			VA		
Stick Length	2.20 m (7'3")	2.50 m (8'2")	2.90 m (9'6")	2.20 m (7'3")	2.50 m (8'2")	2.90 m (9'6")
H110 S	✓	✓	✓	✓	✓	✓
H115 S	✓	✓	✓	✓	✓	✓
H120 S	✓	✓	✓	✓	✓	✓

Cat Pin Grabber Coupler *(continued)*

Undercarriage	Rear Blade					
Counterweight	3.7 mt					
Boom Type	1 PC			VA		
Stick Length	2.20 m (7'3")	2.50 m (8'2")	2.90 m (9'6")	2.20 m (7'3")	2.50 m (8'2")	2.90 m (9'6")
H110 S	✓	✓	✓	✓	✓	✓
H115 S	✓	✓	✓	✓	✓	✓
H120 S	✓	✓*	✓	✓*	✓	✓

Cat Pin Grabber Coupler *(continued)*

Undercarriage	Rear Blade					
Counterweight	4.2 mt					
Boom Type	1 PC			VA		
Stick Length	2.20 m (7'3")	2.50 m (8'2")	2.90 m (9'6")	2.20 m (7'3")	2.50 m (8'2")	2.90 m (9'6")
H110 S	✓	✓	✓	✓	✓	✓
H115 S	✓	✓	✓	✓	✓	✓
H120 S	✓	✓	✓*	✓	✓	✓

(continued on next page)

Hammer Technical Specifications

Matching – Wheeled Excavators *(continued)*

Match
 Working Range Front Only
 Allowed Usage on Machine Less Than 50%
 No Match

M318 *(continued)*

Cat Pin Grabber Coupler *(continued)*

Undercarriage	Rear Blade (Wide U/C)					
Counterweight	3.7 mt					
Boom Type	1 PC			VA		
Stick Length	2.20 m (7'3")	2.50 m (8'2")	2.90 m (9'6")	2.20 m (7'3")	2.50 m (8'2")	2.90 m (9'6")
H110 S	✓	✓	✓	✓	✓	✓
H115 S	✓	✓	✓	✓	✓	✓
H120 S	✓	✓	✓	✓	✓	✓*

Cat Pin Grabber Coupler *(continued)*

Undercarriage	Rear Blade (Wide U/C)					
Counterweight	4.2 mt					
Boom Type	1 PC			VA		
Stick Length	2.20 m (7'3")	2.50 m (8'2")	2.90 m (9'6")	2.20 m (7'3")	2.50 m (8'2")	2.90 m (9'6")
H110 S	✓	✓	✓	✓	✓	✓
H115 S	✓	✓	✓	✓	✓	✓
H120 S	✓	✓	✓	✓	✓	✓

CW-30 S Dedicated Coupler

Undercarriage	Front and Rear Outriggers					
Counterweight	3.7 mt					
Boom Type	1 PC			VA		
Stick Length	2.20 m (7'3")	2.50 m (8'2")	2.90 m (9'6")	2.20 m (7'3")	2.50 m (8'2")	2.90 m (9'6")
H110 S	✓	✓	✓	✓	✓	✓
H115 S	✓	✓	✓	✓	✓	✓
H120 S	✓	✓	✓	✓		✓

CW-30 S Dedicated Coupler *(continued)*

Undercarriage	Front and Rear Outriggers					
Counterweight	4.2 mt					
Boom Type	1 PC			VA		
Stick Length	2.20 m (7'3")	2.50 m (8'2")	2.90 m (9'6")	2.20 m (7'3")	2.50 m (8'2")	2.90 m (9'6")
H110 S	✓	✓	✓	✓	✓	✓
H115 S	✓	✓	✓	✓	✓	✓
H120 S	✓	✓	✓	✓		✓

CW-30 S Dedicated Coupler *(continued)*

Undercarriage	Front Blade; Rear Outriggers					
Counterweight	3.7 mt					
Boom Type	1 PC			VA		
Stick Length	2.20 m (7'3")	2.50 m (8'2")	2.90 m (9'6")	2.20 m (7'3")	2.50 m (8'2")	2.90 m (9'6")
H110 S	✓	✓	✓	✓	✓	✓
H115 S	✓	✓	✓	✓	✓	✓
H120 S	✓	✓	✓	✓		✓

(continued on next page)

Matching – Wheeled Excavators *(continued)*

Match
 * Working Range Front Only
 † Allowed Usage on Machine Less Than 50%
 No Match

M318 *(continued)*

CW-30 S Dedicated Coupler *(continued)*

Undercarriage	Front Blade; Rear Outriggers					
Counterweight	4.2 mt					
Boom Type	1 PC			VA		
Stick Length	2.20 m (7'3")	2.50 m (8'2")	2.90 m (9'6")	2.20 m (7'3")	2.50 m (8'2")	2.90 m (9'6")
H110 S	✓	✓	✓	✓	✓	✓
H115 S	✓	✓	✓	✓	✓	✓
H120 S	✓	✓	✓	✓		✓

CW-30 S Dedicated Coupler *(continued)*

Undercarriage	Front Outriggers; Rear Blade (Wide U/C)					
Counterweight	3.7 mt					
Boom Type	1 PC			VA		
Stick Length	2.20 m (7'3")	2.50 m (8'2")	2.90 m (9'6")	2.20 m (7'3")	2.50 m (8'2")	2.90 m (9'6")
H110 S	✓	✓	✓	✓	✓	✓
H115 S	✓	✓	✓	✓	✓	✓
H120 S	✓	✓	✓	✓		✓

CW-30 S Dedicated Coupler *(continued)*

Undercarriage	Front Outriggers; Rear Blade (Wide U/C)					
Counterweight	4.2 mt					
Boom Type	1 PC			VA		
Stick Length	2.20 m (7'3")	2.50 m (8'2")	2.90 m (9'6")	2.20 m (7'3")	2.50 m (8'2")	2.90 m (9'6")
H110 S	✓	✓	✓	✓	✓	✓
H115 S	✓	✓	✓	✓	✓	✓
H120 S	✓	✓	✓	✓		✓

CW-30 S Dedicated Coupler *(continued)*

Undercarriage	Front Outriggers; Rear Blade					
Counterweight	3.7 mt					
Boom Type	1 PC			VA		
Stick Length	2.20 m (7'3")	2.50 m (8'2")	2.90 m (9'6")	2.20 m (7'3")	2.50 m (8'2")	2.90 m (9'6")
H110 S	✓	✓	✓	✓	✓	✓
H115 S	✓	✓	✓	✓	✓	✓
H120 S	✓	✓	✓	✓		✓

CW-30 S Dedicated Coupler *(continued)*

Undercarriage	Front Outriggers; Rear Blade					
Counterweight	4.2 mt					
Boom Type	1 PC			VA		
Stick Length	2.20 m (7'3")	2.50 m (8'2")	2.90 m (9'6")	2.20 m (7'3")	2.50 m (8'2")	2.90 m (9'6")
H110 S	✓	✓	✓	✓	✓	✓
H115 S	✓	✓	✓	✓	✓	✓
H120 S	✓	✓	✓	✓		✓

(continued on next page)

Hammer Technical Specifications

Matching – Wheeled Excavators (continued)

Match
 * Working Range Front Only
 † Allowed Usage on Machine Less Than 50%
 No Match

M318 (continued)

CW-30 S Dedicated Coupler (continued)

Undercarriage	Rear Blade					
Counterweight	3.7 mt					
Boom Type	1 PC			VA		
Stick Length	2.20 m (7'3")	2.50 m (8'2")	2.90 m (9'6")	2.20 m (7'3")	2.50 m (8'2")	2.90 m (9'6")
H110 S	✓	✓	✓	✓	✓	✓
H115 S	✓	✓	✓	✓	✓	✓
H120 S		✓	✓			

CW-30 S Dedicated Coupler (continued)

Undercarriage	Rear Blade					
Counterweight	4.2 mt					
Boom Type	1 PC			VA		
Stick Length	2.20 m (7'3")	2.50 m (8'2")	2.90 m (9'6")	2.20 m (7'3")	2.50 m (8'2")	2.90 m (9'6")
H110 S	✓	✓	✓	✓	✓	✓
H115 S	✓	✓	✓	✓	✓	✓
H120 S	✓	✓	✓			✓

CW-30 S Dedicated Coupler (continued)

Undercarriage	Rear Blade (Wide U/C)					
Counterweight	3.7 mt					
Boom Type	1 PC			VA		
Stick Length	2.20 m (7'3")	2.50 m (8'2")	2.90 m (9'6")	2.20 m (7'3")	2.50 m (8'2")	2.90 m (9'6")
H110 S	✓	✓	✓	✓	✓	✓
H115 S	✓	✓	✓	✓	✓	✓
H120 S	✓	✓	✓	✓*		✓

CW-30 S Dedicated Coupler (continued)

Undercarriage	Rear Blade (Wide U/C)					
Counterweight	4.2 mt					
Boom Type	1 PC			VA		
Stick Length	2.20 m (7'3")	2.50 m (8'2")	2.90 m (9'6")	2.20 m (7'3")	2.50 m (8'2")	2.90 m (9'6")
H110 S	✓	✓	✓	✓	✓	✓
H115 S	✓	✓	✓	✓	✓	✓
H120 S	✓	✓	✓	✓		✓

CW-30 Dedicated Coupler

Undercarriage	Front and Rear Outriggers					
Counterweight	3.7 mt					
Boom Type	1 PC			VA		
Stick Length	2.20 m (7'3")	2.50 m (8'2")	2.90 m (9'6")	2.20 m (7'3")	2.50 m (8'2")	2.90 m (9'6")
H110 S	✓	✓	✓	✓	✓	✓
H115 S	✓	✓	✓	✓	✓	✓
H120 S	✓	✓	✓	✓	✓	✓

(continued on next page)

Matching – Wheeled Excavators (continued)

Match
 Working Range Front Only
 Allowed Usage on Machine Less Than 50%
 No Match

M318 (continued)

CW-30 Dedicated Coupler (continued)

Undercarriage	Front and Rear Outriggers					
Counterweight	4.2 mt					
Boom Type	1 PC			VA		
Stick Length	2.20 m (7'3")	2.50 m (8'2")	2.90 m (9'6")	2.20 m (7'3")	2.50 m (8'2")	2.90 m (9'6")
H110 S	✓	✓	✓	✓	✓	✓
H115 S	✓	✓	✓	✓	✓	✓
H120 S	✓	✓	✓	✓	✓	✓

CW-30 Dedicated Coupler (continued)

Undercarriage	Front Blade; Rear Outriggers					
Counterweight	3.7 mt					
Boom Type	1 PC			VA		
Stick Length	2.20 m (7'3")	2.50 m (8'2")	2.90 m (9'6")	2.20 m (7'3")	2.50 m (8'2")	2.90 m (9'6")
H110 S	✓	✓	✓	✓	✓	✓
H115 S	✓	✓	✓	✓	✓	✓
H120 S	✓	✓	✓	✓	✓	✓

CW-30 Dedicated Coupler (continued)

Undercarriage	Front Blade; Rear Outriggers					
Counterweight	4.2 mt					
Boom Type	1 PC			VA		
Stick Length	2.20 m (7'3")	2.50 m (8'2")	2.90 m (9'6")	2.20 m (7'3")	2.50 m (8'2")	2.90 m (9'6")
H110 S	✓	✓	✓	✓	✓	✓
H115 S	✓	✓	✓	✓	✓	✓
H120 S	✓	✓	✓	✓	✓	✓

CW-30 Dedicated Coupler (continued)

Undercarriage	Front Outriggers; Rear Blade (Wide U/C)					
Counterweight	3.7 mt					
Boom Type	1 PC			VA		
Stick Length	2.20 m (7'3")	2.50 m (8'2")	2.90 m (9'6")	2.20 m (7'3")	2.50 m (8'2")	2.90 m (9'6")
H110 S	✓	✓	✓	✓	✓	✓
H115 S	✓	✓	✓	✓	✓	✓
H120 S	✓	✓	✓	✓	✓	✓

CW-30 Dedicated Coupler (continued)

Undercarriage	Front Outriggers; Rear Blade (Wide U/C)					
Counterweight	4.2 mt					
Boom Type	1 PC			VA		
Stick Length	2.20 m (7'3")	2.50 m (8'2")	2.90 m (9'6")	2.20 m (7'3")	2.50 m (8'2")	2.90 m (9'6")
H110 S	✓	✓	✓	✓	✓	✓
H115 S	✓	✓	✓	✓	✓	✓
H120 S	✓	✓	✓	✓	✓	✓

(continued on next page)

Hammer Technical Specifications

Matching – Wheeled Excavators (continued)

Match
 * Working Range Front Only
 † Allowed Usage on Machine Less Than 50%
 No Match

M318 (continued)

CW-30 Dedicated Coupler (continued)

Undercarriage	Front Outriggers; Rear Blade					
Counterweight	3.7 mt					
Boom Type	1 PC			VA		
Stick Length	2.20 m (7'3")	2.50 m (8'2")	2.90 m (9'6")	2.20 m (7'3")	2.50 m (8'2")	2.90 m (9'6")
H110 S	✓	✓	✓	✓	✓	✓
H115 S	✓	✓	✓	✓	✓	✓
H120 S	✓	✓	✓	✓	✓	✓

CW-30 Dedicated Coupler (continued)

Undercarriage	Front Outriggers; Rear Blade					
Counterweight	4.2 mt					
Boom Type	1 PC			VA		
Stick Length	2.20 m (7'3")	2.50 m (8'2")	2.90 m (9'6")	2.20 m (7'3")	2.50 m (8'2")	2.90 m (9'6")
H110 S	✓	✓	✓	✓	✓	✓
H115 S	✓	✓	✓	✓	✓	✓
H120 S	✓	✓	✓	✓	✓	✓

CW-30 Dedicated Coupler (continued)

Undercarriage	Rear Blade					
Counterweight	3.7 mt					
Boom Type	1 PC			VA		
Stick Length	2.20 m (7'3")	2.50 m (8'2")	2.90 m (9'6")	2.20 m (7'3")	2.50 m (8'2")	2.90 m (9'6")
H110 S	✓	✓	✓	✓	✓	✓
H115 S	✓	✓	✓	✓	✓	✓
H120 S	✓	✓*		✓*		

CW-30 Dedicated Coupler (continued)

Undercarriage	Rear Blade					
Counterweight	4.2 mt					
Boom Type	1 PC			VA		
Stick Length	2.20 m (7'3")	2.50 m (8'2")	2.90 m (9'6")	2.20 m (7'3")	2.50 m (8'2")	2.90 m (9'6")
H110 S	✓	✓	✓	✓	✓	✓
H115 S	✓	✓	✓	✓	✓	✓
H120 S	✓	✓	✓*	✓	✓	✓*

CW-30 Dedicated Coupler (continued)

Undercarriage	Rear Blade (Wide U/C)					
Counterweight	3.7 mt					
Boom Type	1 PC			VA		
Stick Length	2.20 m (7'3")	2.50 m (8'2")	2.90 m (9'6")	2.20 m (7'3")	2.50 m (8'2")	2.90 m (9'6")
H110 S	✓	✓	✓	✓	✓	✓
H115 S	✓	✓	✓	✓	✓	✓
H120 S	✓	✓	✓	✓	✓	✓*

(continued on next page)

Matching – Wheeled Excavators (continued)

Match
 * Working Range Front Only
 † Allowed Usage on Machine Less Than 50%
 No Match

M318 (continued)

CW-30 Dedicated Coupler (continued)

Undercarriage	Rear Blade (Wide U/C)					
Counterweight	4.2 mt					
Boom Type	1 PC			VA		
Stick Length	2.20 m (7'3")	2.50 m (8'2")	2.90 m (9'6")	2.20 m (7'3")	2.50 m (8'2")	2.90 m (9'6")
H110 S	✓	✓	✓	✓	✓	✓
H115 S	✓	✓	✓	✓	✓	✓
H120 S	✓	✓	✓	✓	✓	✓

S60 Dedicated Coupler

Undercarriage	Front and Rear Outriggers					
Counterweight	3.7 mt					
Boom Type	1 PC			VA		
Stick Length	2.20 m (7'3")	2.50 m (8'2")	2.90 m (9'6")	2.20 m (7'3")	2.50 m (8'2")	2.90 m (9'6")
H110 S	✓	✓	✓	✓	✓	✓
H115 S	✓	✓	✓	✓	✓	✓

S60 Dedicated Coupler (continued)

Undercarriage	Front and Rear Outriggers					
Counterweight	4.2 mt					
Boom Type	1 PC			VA		
Stick Length	2.20 m (7'3")	2.50 m (8'2")	2.90 m (9'6")	2.20 m (7'3")	2.50 m (8'2")	2.90 m (9'6")
H110 S	✓	✓	✓	✓	✓	✓
H115 S	✓	✓	✓	✓	✓	✓

S60 Dedicated Coupler (continued)

Undercarriage	Front Blade; Rear Outriggers					
Counterweight	3.7 mt					
Boom Type	1 PC			VA		
Stick Length	2.20 m (7'3")	2.50 m (8'2")	2.90 m (9'6")	2.20 m (7'3")	2.50 m (8'2")	2.90 m (9'6")
H110 S	✓	✓	✓	✓	✓	✓
H115 S	✓	✓	✓	✓	✓	✓

S60 Dedicated Coupler (continued)

Undercarriage	Front Blade; Rear Outriggers					
Counterweight	4.2 mt					
Boom Type	1 PC			VA		
Stick Length	2.20 m (7'3")	2.50 m (8'2")	2.90 m (9'6")	2.20 m (7'3")	2.50 m (8'2")	2.90 m (9'6")
H110 S	✓	✓	✓	✓	✓	✓
H115 S	✓	✓	✓	✓	✓	✓

S60 Dedicated Coupler (continued)

Undercarriage	Front Outriggers; Rear Blade (Wide U/C)					
Counterweight	3.7 mt					
Boom Type	1 PC			VA		
Stick Length	2.20 m (7'3")	2.50 m (8'2")	2.90 m (9'6")	2.20 m (7'3")	2.50 m (8'2")	2.90 m (9'6")
H110 S	✓	✓	✓	✓	✓	✓
H115 S	✓	✓	✓	✓	✓	✓

(continued on next page)

Hammer Technical Specifications

Matching – Wheeled Excavators (continued)

Match
 Working Range Front Only
 Allowed Usage on Machine Less Than 50%
 No Match

M318 (continued)

S60 Dedicated Coupler (continued)

Undercarriage	Front Outriggers; Rear Blade (Wide U/C)					
Counterweight	4.2 mt					
Boom Type	1 PC			VA		
Stick Length	2.20 m (7'3")	2.50 m (8'2")	2.90 m (9'6")	2.20 m (7'3")	2.50 m (8'2")	2.90 m (9'6")
H110 S	✓	✓	✓	✓	✓	✓
H115 S	✓	✓	✓	✓	✓	✓

S60 Dedicated Coupler (continued)

Undercarriage	Front Outriggers; Rear Blade					
Counterweight	3.7 mt					
Boom Type	1 PC			VA		
Stick Length	2.20 m (7'3")	2.50 m (8'2")	2.90 m (9'6")	2.20 m (7'3")	2.50 m (8'2")	2.90 m (9'6")
H110 S	✓	✓	✓	✓	✓	✓
H115 S	✓	✓	✓	✓	✓	✓

S60 Dedicated Coupler (continued)

Undercarriage	Front Outriggers; Rear Blade					
Counterweight	4.2 mt					
Boom Type	1 PC			VA		
Stick Length	2.20 m (7'3")	2.50 m (8'2")	2.90 m (9'6")	2.20 m (7'3")	2.50 m (8'2")	2.90 m (9'6")
H110 S	✓	✓	✓	✓	✓	✓
H115 S	✓	✓	✓	✓	✓	✓

S60 Dedicated Coupler (continued)

Undercarriage	Rear Blade					
Counterweight	3.7 mt					
Boom Type	1 PC			VA		
Stick Length	2.20 m (7'3")	2.50 m (8'2")	2.90 m (9'6")	2.20 m (7'3")	2.50 m (8'2")	2.90 m (9'6")
H110 S	✓	✓	✓	✓	✓	✓
H115 S	✓	✓	✓	✓	✓	✓

S60 Dedicated Coupler (continued)

Undercarriage	Rear Blade					
Counterweight	4.2 mt					
Boom Type	1 PC			VA		
Stick Length	2.20 m (7'3")	2.50 m (8'2")	2.90 m (9'6")	2.20 m (7'3")	2.50 m (8'2")	2.90 m (9'6")
H110 S	✓	✓	✓	✓	✓	✓
H115 S	✓	✓	✓	✓	✓	✓

S60 Dedicated Coupler (continued)

Undercarriage	Rear Blade (Wide U/C)					
Counterweight	3.7 mt					
Boom Type	1 PC			VA		
Stick Length	2.20 m (7'3")	2.50 m (8'2")	2.90 m (9'6")	2.20 m (7'3")	2.50 m (8'2")	2.90 m (9'6")
H110 S	✓	✓	✓	✓	✓	✓
H115 S	✓	✓	✓	✓	✓	✓

(continued on next page)

Matching – Wheeled Excavators *(continued)*

Match
 * Working Range Front Only
 † Allowed Usage on Machine Less Than 50%
 No Match

M318 *(continued)*

S60 Dedicated Coupler *(continued)*

Undercarriage	Rear Blade (Wide U/C)					
Counterweight	4.2 mt					
Boom Type	1 PC			VA		
Stick Length	2.20 m (7'3")	2.50 m (8'2")	2.90 m (9'6")	2.20 m (7'3")	2.50 m (8'2")	2.90 m (9'6")
H110 S	✓	✓	✓	✓	✓	✓
H115 S	✓	✓	✓	✓	✓	✓

HCS60 Dedicated Coupler

Undercarriage	Front and Rear Outriggers					
Counterweight	3.7 mt					
Boom Type	1 PC			VA		
Stick Length	2.20 m (7'3")	2.50 m (8'2")	2.90 m (9'6")	2.20 m (7'3")	2.50 m (8'2")	2.90 m (9'6")
H110 S	✓	✓	✓	✓	✓	✓
H115 S	✓	✓	✓	✓	✓	✓
H120 S	✓	✓	✓	✓	✓	✓

HCS60 Dedicated Coupler *(continued)*

Undercarriage	Front and Rear Outriggers					
Counterweight	4.2 mt					
Boom Type	1 PC			VA		
Stick Length	2.20 m (7'3")	2.50 m (8'2")	2.90 m (9'6")	2.20 m (7'3")	2.50 m (8'2")	2.90 m (9'6")
H110 S	✓	✓	✓	✓	✓	✓
H115 S	✓	✓	✓	✓	✓	✓
H120 S	✓	✓	✓	✓	✓	✓

HCS60 Dedicated Coupler *(continued)*

Undercarriage	Front Blade; Rear Outriggers					
Counterweight	3.7 mt					
Boom Type	1 PC			VA		
Stick Length	2.20 m (7'3")	2.50 m (8'2")	2.90 m (9'6")	2.20 m (7'3")	2.50 m (8'2")	2.90 m (9'6")
H110 S	✓	✓	✓	✓	✓	✓
H115 S	✓	✓	✓	✓	✓	✓
H120 S	✓	✓	✓	✓	✓	✓

HCS60 Dedicated Coupler *(continued)*

Undercarriage	Front Blade; Rear Outriggers					
Counterweight	4.2 mt					
Boom Type	1 PC			VA		
Stick Length	2.20 m (7'3")	2.50 m (8'2")	2.90 m (9'6")	2.20 m (7'3")	2.50 m (8'2")	2.90 m (9'6")
H110 S	✓	✓	✓	✓	✓	✓
H115 S	✓	✓	✓	✓	✓	✓
H120 S	✓	✓	✓	✓	✓	✓

(continued on next page)

Hammer Technical Specifications

Matching – Wheeled Excavators *(continued)*

Match
 * Working Range Front Only
 † Allowed Usage on Machine Less Than 50%
 No Match

M318 *(continued)*

HCS60 Dedicated Coupler *(continued)*

Undercarriage	Front Outriggers; Rear Blade (Wide U/C)					
Counterweight	3.7 mt					
Boom Type	1 PC			VA		
Stick Length	2.20 m (7'3")	2.50 m (8'2")	2.90 m (9'6")	2.20 m (7'3")	2.50 m (8'2")	2.90 m (9'6")
H110 S	✓	✓	✓	✓	✓	✓
H115 S	✓	✓	✓	✓	✓	✓
H120 S	✓	✓	✓	✓	✓	✓

HCS60 Dedicated Coupler *(continued)*

Undercarriage	Front Outriggers; Rear Blade (Wide U/C)					
Counterweight	4.2 mt					
Boom Type	1 PC			VA		
Stick Length	2.20 m (7'3")	2.50 m (8'2")	2.90 m (9'6")	2.20 m (7'3")	2.50 m (8'2")	2.90 m (9'6")
H110 S	✓	✓	✓	✓	✓	✓
H115 S	✓	✓	✓	✓	✓	✓
H120 S	✓	✓	✓	✓	✓	✓

HCS60 Dedicated Coupler *(continued)*

Undercarriage	Front Outriggers; Rear Blade					
Counterweight	3.7 mt					
Boom Type	1 PC			VA		
Stick Length	2.20 m (7'3")	2.50 m (8'2")	2.90 m (9'6")	2.20 m (7'3")	2.50 m (8'2")	2.90 m (9'6")
H110 S	✓	✓	✓	✓	✓	✓
H115 S	✓	✓	✓	✓	✓	✓
H120 S	✓	✓	✓	✓	✓	✓

HCS60 Dedicated Coupler *(continued)*

Undercarriage	Front Outriggers; Rear Blade					
Counterweight	4.2 mt					
Boom Type	1 PC			VA		
Stick Length	2.20 m (7'3")	2.50 m (8'2")	2.90 m (9'6")	2.20 m (7'3")	2.50 m (8'2")	2.90 m (9'6")
H110 S	✓	✓	✓	✓	✓	✓
H115 S	✓	✓	✓	✓	✓	✓
H120 S	✓	✓	✓	✓	✓	✓

HCS60 Dedicated Coupler *(continued)*

Undercarriage	Rear Blade					
Counterweight	3.7 mt					
Boom Type	1 PC			VA		
Stick Length	2.20 m (7'3")	2.50 m (8'2")	2.90 m (9'6")	2.20 m (7'3")	2.50 m (8'2")	2.90 m (9'6")
H110 S	✓	✓	✓	✓	✓	✓
H115 S	✓	✓	✓	✓	✓	✓
H120 S	✓	✓	✓	✓	✓	✓

(continued on next page)

Matching – Wheeled Excavators *(continued)*

Match
 * Working Range Front Only
 † Allowed Usage on Machine Less Than 50%
 No Match

M318 *(continued)*

HCS60 Dedicated Coupler *(continued)*

Undercarriage	Rear Blade					
Counterweight	4.2 mt					
Boom Type	1 PC			VA		
Stick Length	2.20 m (7'3")	2.50 m (8'2")	2.90 m (9'6")	2.20 m (7'3")	2.50 m (8'2")	2.90 m (9'6")
H110 S	✓	✓	✓	✓	✓	✓
H115 S	✓	✓	✓	✓	✓	✓
H120 S	✓	✓	✓	✓	✓	✓

HCS60 Dedicated Coupler *(continued)*

Undercarriage	Rear Blade (Wide U/C)					
Counterweight	3.7 mt					
Boom Type	1 PC			VA		
Stick Length	2.20 m (7'3")	2.50 m (8'2")	2.90 m (9'6")	2.20 m (7'3")	2.50 m (8'2")	2.90 m (9'6")
H110 S	✓	✓	✓	✓	✓	✓
H115 S	✓	✓	✓	✓	✓	✓
H120 S	✓	✓	✓	✓	✓	✓

HCS60 Dedicated Coupler *(continued)*

Undercarriage	Rear Blade (Wide U/C)					
Counterweight	4.2 mt					
Boom Type	1 PC			VA		
Stick Length	2.20 m (7'3")	2.50 m (8'2")	2.90 m (9'6")	2.20 m (7'3")	2.50 m (8'2")	2.90 m (9'6")
H110 S	✓	✓	✓	✓	✓	✓
H115 S	✓	✓	✓	✓	✓	✓
H120 S	✓	✓	✓	✓	✓	✓

HCS65 Dedicated Coupler

Undercarriage	Front and Rear Outriggers					
Counterweight	3.7 mt					
Boom Type	1 PC			VA		
Stick Length	2.20 m (7'3")	2.50 m (8'2")	2.90 m (9'6")	2.20 m (7'3")	2.50 m (8'2")	2.90 m (9'6")
H110 S	✓	✓	✓	✓	✓	✓
H115 S	✓	✓	✓	✓	✓	✓
H120 S	✓	✓	✓	✓	✓	✓

HCS65 Dedicated Coupler *(continued)*

Undercarriage	Front and Rear Outriggers					
Counterweight	4.2 mt					
Boom Type	1 PC			VA		
Stick Length	2.20 m (7'3")	2.50 m (8'2")	2.90 m (9'6")	2.20 m (7'3")	2.50 m (8'2")	2.90 m (9'6")
H110 S	✓	✓	✓	✓	✓	✓
H115 S	✓	✓	✓	✓	✓	✓
H120 S	✓	✓	✓	✓	✓	✓

(continued on next page)

Hammer Technical Specifications

Matching – Wheeled Excavators *(continued)*

Match
 * Working Range Front Only
 † Allowed Usage on Machine Less Than 50%
 No Match

M318 *(continued)*

HCS65 Dedicated Coupler *(continued)*

Undercarriage	Front Blade; Rear Outriggers					
Counterweight	3.7 mt					
Boom Type	1 PC			VA		
Stick Length	2.20 m (7'3")	2.50 m (8'2")	2.90 m (9'6")	2.20 m (7'3")	2.50 m (8'2")	2.90 m (9'6")
H110 S	✓	✓	✓	✓	✓	✓
H115 S	✓	✓	✓	✓	✓	✓
H120 S	✓	✓	✓	✓	✓	✓

HCS65 Dedicated Coupler *(continued)*

Undercarriage	Front Blade; Rear Outriggers					
Counterweight	4.2 mt					
Boom Type	1 PC			VA		
Stick Length	2.20 m (7'3")	2.50 m (8'2")	2.90 m (9'6")	2.20 m (7'3")	2.50 m (8'2")	2.90 m (9'6")
H110 S	✓	✓	✓	✓	✓	✓
H115 S	✓	✓	✓	✓	✓	✓
H120 S	✓	✓	✓	✓	✓	✓

HCS65 Dedicated Coupler *(continued)*

Undercarriage	Front Outriggers; Rear Blade (Wide U/C)					
Counterweight	3.7 mt					
Boom Type	1 PC			VA		
Stick Length	2.20 m (7'3")	2.50 m (8'2")	2.90 m (9'6")	2.20 m (7'3")	2.50 m (8'2")	2.90 m (9'6")
H110 S	✓	✓	✓	✓	✓	✓
H115 S	✓	✓	✓	✓	✓	✓
H120 S	✓	✓	✓	✓	✓	✓

HCS65 Dedicated Coupler *(continued)*

Undercarriage	Front Outriggers; Rear Blade (Wide U/C)					
Counterweight	4.2 mt					
Boom Type	1 PC			VA		
Stick Length	2.20 m (7'3")	2.50 m (8'2")	2.90 m (9'6")	2.20 m (7'3")	2.50 m (8'2")	2.90 m (9'6")
H110 S	✓	✓	✓	✓	✓	✓
H115 S	✓	✓	✓	✓	✓	✓
H120 S	✓	✓	✓	✓	✓	✓

HCS65 Dedicated Coupler *(continued)*

Undercarriage	Front Outriggers; Rear Blade					
Counterweight	3.7 mt					
Boom Type	1 PC			VA		
Stick Length	2.20 m (7'3")	2.50 m (8'2")	2.90 m (9'6")	2.20 m (7'3")	2.50 m (8'2")	2.90 m (9'6")
H110 S	✓	✓	✓	✓	✓	✓
H115 S	✓	✓	✓	✓	✓	✓
H120 S	✓	✓	✓	✓	✓	✓

(continued on next page)

Matching – Wheeled Excavators *(continued)*

Match
 * Working Range Front Only
 † Allowed Usage on Machine Less Than 50%
 No Match

M318 *(continued)*

HCS65 Dedicated Coupler *(continued)*

Undercarriage	Front Outriggers; Rear Blade					
Counterweight	4.2 mt					
Boom Type	1 PC			VA		
Stick Length	2.20 m (7'3")	2.50 m (8'2")	2.90 m (9'6")	2.20 m (7'3")	2.50 m (8'2")	2.90 m (9'6")
H110 S	✓	✓	✓	✓	✓	✓
H115 S	✓	✓	✓	✓	✓	✓
H120 S	✓	✓	✓	✓	✓	✓

HCS65 Dedicated Coupler *(continued)*

Undercarriage	Rear Blade					
Counterweight	3.7 mt					
Boom Type	1 PC			VA		
Stick Length	2.20 m (7'3")	2.50 m (8'2")	2.90 m (9'6")	2.20 m (7'3")	2.50 m (8'2")	2.90 m (9'6")
H110 S	✓	✓	✓	✓	✓	✓
H115 S	✓	✓	✓	✓	✓	✓
H120 S	✓	✓	✓	✓	✓	✓

HCS65 Dedicated Coupler *(continued)*

Undercarriage	Rear Blade					
Counterweight	4.2 mt					
Boom Type	1 PC			VA		
Stick Length	2.20 m (7'3")	2.50 m (8'2")	2.90 m (9'6")	2.20 m (7'3")	2.50 m (8'2")	2.90 m (9'6")
H110 S	✓	✓	✓	✓	✓	✓
H115 S	✓	✓	✓	✓	✓	✓
H120 S	✓	✓	✓	✓	✓	✓

HCS65 Dedicated Coupler *(continued)*

Undercarriage	Rear Blade (Wide U/C)					
Counterweight	3.7 mt					
Boom Type	1 PC			VA		
Stick Length	2.20 m (7'3")	2.50 m (8'2")	2.90 m (9'6")	2.20 m (7'3")	2.50 m (8'2")	2.90 m (9'6")
H110 S	✓	✓	✓	✓	✓	✓
H115 S	✓	✓	✓	✓	✓	✓
H120 S	✓	✓	✓	✓	✓	✓

HCS65 Dedicated Coupler *(continued)*

Undercarriage	Rear Blade (Wide U/C)					
Counterweight	4.2 mt					
Boom Type	1 PC			VA		
Stick Length	2.20 m (7'3")	2.50 m (8'2")	2.90 m (9'6")	2.20 m (7'3")	2.50 m (8'2")	2.90 m (9'6")
H110 S	✓	✓	✓	✓	✓	✓
H115 S	✓	✓	✓	✓	✓	✓
H120 S	✓	✓	✓	✓	✓	✓

(continued on next page)

Hammer Technical Specifications

Matching – Wheeled Excavators *(continued)*

Match
 Working Range Front Only
 Allowed Usage on Machine Less Than 50%
 No Match

M318 *(continued)*

Tilt-Rotator TRS14 with CW30 S Dedicated Coupler

Undercarriage	Front and Rear Outriggers					
Counterweight	3.7 mt					
Boom Type	1 PC			VA		
Stick Length	2.20 m (7'3")	2.50 m (8'2")	2.90 m (9'6")	2.20 m (7'3")	2.50 m (8'2")	2.90 m (9'6")
H110 S	✓	✓	✓	✓	✓	✓
H115 S	✓	✓	✓		✓	✓

Tilt-Rotator TRS14 with CW30 S Dedicated Coupler *(continued)*

Undercarriage	Front and Rear Outriggers					
Counterweight	4.2 mt					
Boom Type	1 PC			VA		
Stick Length	2.20 m (7'3")	2.50 m (8'2")	2.90 m (9'6")	2.20 m (7'3")	2.50 m (8'2")	2.90 m (9'6")
H110 S	✓	✓	✓	✓	✓	✓
H115 S	✓	✓	✓		✓	✓

Tilt-Rotator TRS14 with CW30 S Dedicated Coupler *(continued)*

Undercarriage	Front Blade; Rear Outriggers					
Counterweight	3.7 mt					
Boom Type	1 PC			VA		
Stick Length	2.20 m (7'3")	2.50 m (8'2")	2.90 m (9'6")	2.20 m (7'3")	2.50 m (8'2")	2.90 m (9'6")
H110 S	✓	✓	✓	✓	✓	✓
H115 S	✓	✓	✓		✓	✓

Tilt-Rotator TRS14 with CW30 S Dedicated Coupler *(continued)*

Undercarriage	Front Blade; Rear Outriggers					
Counterweight	4.2 mt					
Boom Type	1 PC			VA		
Stick Length	2.20 m (7'3")	2.50 m (8'2")	2.90 m (9'6")	2.20 m (7'3")	2.50 m (8'2")	2.90 m (9'6")
H110 S	✓	✓	✓	✓	✓	✓
H115 S	✓	✓	✓		✓	✓

Tilt-Rotator TRS14 with CW30 S Dedicated Coupler *(continued)*

Undercarriage	Front Outriggers; Rear Blade (Wide U/C)					
Counterweight	3.7 mt					
Boom Type	1 PC			VA		
Stick Length	2.20 m (7'3")	2.50 m (8'2")	2.90 m (9'6")	2.20 m (7'3")	2.50 m (8'2")	2.90 m (9'6")
H110 S	✓	✓	✓	✓	✓	✓
H115 S	✓	✓	✓		✓	✓

Tilt-Rotator TRS14 with CW30 S Dedicated Coupler *(continued)*

Undercarriage	Front Outriggers; Rear Blade (Wide U/C)					
Counterweight	4.2 mt					
Boom Type	1 PC			VA		
Stick Length	2.20 m (7'3")	2.50 m (8'2")	2.90 m (9'6")	2.20 m (7'3")	2.50 m (8'2")	2.90 m (9'6")
H110 S	✓	✓	✓	✓	✓	✓
H115 S	✓	✓	✓		✓	✓

(continued on next page)

Matching – Wheeled Excavators *(continued)*

Match
 * Working Range Front Only
 † Allowed Usage on Machine Less Than 50%
 No Match

M318 *(continued)*

Tilt-Rotator TRS14 with CW30 S Dedicated Coupler *(continued)*

Undercarriage	Front Outriggers; Rear Blade					
Counterweight	3.7 mt					
Boom Type	1 PC			VA		
Stick Length	2.20 m (7'3")	2.50 m (8'2")	2.90 m (9'6")	2.20 m (7'3")	2.50 m (8'2")	2.90 m (9'6")
H110 S	✓	✓	✓	✓	✓	✓
H115 S	✓	✓	✓		✓	✓

Tilt-Rotator TRS14 with CW30 S Dedicated Coupler *(continued)*

Undercarriage	Front Outriggers; Rear Blade					
Counterweight	4.2 mt					
Boom Type	1 PC			VA		
Stick Length	2.20 m (7'3")	2.50 m (8'2")	2.90 m (9'6")	2.20 m (7'3")	2.50 m (8'2")	2.90 m (9'6")
H110 S	✓	✓	✓	✓	✓	✓
H115 S	✓	✓	✓		✓	✓

Tilt-Rotator TRS14 with CW30 S Dedicated Coupler *(continued)*

Undercarriage	Rear Blade					
Counterweight	3.7 mt					
Boom Type	1 PC			VA		
Stick Length	2.20 m (7'3")	2.50 m (8'2")	2.90 m (9'6")	2.20 m (7'3")	2.50 m (8'2")	2.90 m (9'6")
H110 S	✓	✓	✓	✓	✓	
H115 S	✓	✓				

Tilt-Rotator TRS14 with CW30 S Dedicated Coupler *(continued)*

Undercarriage	Rear Blade					
Counterweight	4.2 mt					
Boom Type	1 PC			VA		
Stick Length	2.20 m (7'3")	2.50 m (8'2")	2.90 m (9'6")	2.20 m (7'3")	2.50 m (8'2")	2.90 m (9'6")
H110 S	✓	✓	✓	✓	✓	✓
H115 S	✓	✓	✓		✓	

Tilt-Rotator TRS14 with CW30 S Dedicated Coupler *(continued)*

Undercarriage	Rear Blade (Wide U/C)					
Counterweight	3.7 mt					
Boom Type	1 PC			VA		
Stick Length	2.20 m (7'3")	2.50 m (8'2")	2.90 m (9'6")	2.20 m (7'3")	2.50 m (8'2")	2.90 m (9'6")
H110 S	✓	✓	✓	✓	✓	✓
H115 S	✓	✓	✓		✓	✓

Tilt-Rotator TRS14 with CW30 S Dedicated Coupler *(continued)*

Undercarriage	Rear Blade (Wide U/C)					
Counterweight	4.2 mt					
Boom Type	1 PC			VA		
Stick Length	2.20 m (7'3")	2.50 m (8'2")	2.90 m (9'6")	2.20 m (7'3")	2.50 m (8'2")	2.90 m (9'6")
H110 S	✓	✓	✓	✓	✓	✓
H115 S	✓	✓	✓		✓	✓

(continued on next page)

Hammer Technical Specifications

Matching – Wheeled Excavators *(continued)*

Match
 * Working Range Front Only
 † Allowed Usage on Machine Less Than 50%
 No Match

M318 *(continued)*

CW30 S – Tilt-Rotator TRS10 – CW30 S

Undercarriage	Front and Rear Outriggers					
Counterweight	3.7 mt			4.2 mt		
Boom Type	1 PC		VA	1 PC		VA
Stick Length	2.20 m (7'3")	2.50 m (8'2")	2.50 m (8'2")	2.20 m (7'3")	2.50 m (8'2")	2.50 m (8'2")
H110 S	✓	✓	✓	✓	✓	✓
H115 S	✓	✓		✓	✓	

CW30 S – Tilt-Rotator TRS10 – CW30 S *(continued)*

Undercarriage	Front Blade; Rear Outriggers					
Counterweight	3.7 mt			4.2 mt		
Boom Type	1 PC		VA	1 PC		VA
Stick Length	2.20 m (7'3")	2.50 m (8'2")	2.50 m (8'2")	2.20 m (7'3")	2.50 m (8'2")	2.50 m (8'2")
H110 S	✓	✓	✓	✓	✓	✓
H115 S	✓	✓		✓	✓	

CW30 S – Tilt-Rotator TRS10 – CW30 S *(continued)*

Undercarriage	Front Outriggers; Rear Blade (Wide U/C)					
Counterweight	3.7 mt			4.2 mt		
Boom Type	1 PC		VA	1 PC		VA
Stick Length	2.20 m (7'3")	2.50 m (8'2")	2.50 m (8'2")	2.20 m (7'3")	2.50 m (8'2")	2.50 m (8'2")
H110 S	✓	✓	✓	✓	✓	✓
H115 S	✓	✓		✓	✓	

CW30 S – Tilt-Rotator TRS10 – CW30 S *(continued)*

Undercarriage	Front Outriggers; Rear Blade					
Counterweight	3.7 mt			4.2 mt		
Boom Type	1 PC		VA	1 PC		VA
Stick Length	2.20 m (7'3")	2.50 m (8'2")	2.50 m (8'2")	2.20 m (7'3")	2.50 m (8'2")	2.50 m (8'2")
H110 S	✓	✓	✓	✓	✓	✓
H115 S	✓	✓		✓	✓	

CW30 S – Tilt-Rotator TRS10 – CW30 S *(continued)*

Undercarriage	Rear Blade			
Counterweight	3.7 mt	4.2 mt		
Boom Type	1 PC	1 PC		VA
Stick Length	2.20 m (7'3")	2.20 m (7'3")	2.50 m (8'2")	2.50 m (8'2")
H110 S	✓	✓	✓	✓
H115 S		✓	✓	

CW30 S – Tilt-Rotator TRS10 – CW30 S *(continued)*

Undercarriage	Rear Blade (Wide U/C)					
Counterweight	3.7 mt			4.2 mt		
Boom Type	1 PC		VA	1 PC		VA
Stick Length	2.20 m (7'3")	2.50 m (8'2")	2.50 m (8'2")	2.20 m (7'3")	2.50 m (8'2")	2.50 m (8'2")
H110 S	✓	✓	✓	✓	✓	✓
H115 S	✓	✓		✓	✓	

(continued on next page)

Matching – Wheeled Excavators *(continued)*

Match
 Working Range Front Only
 Allowed Usage on Machine Less Than 50%
 No Match

M318 *(continued)*

Tilt-Rotator TRS14 with CW30 Dedicated Coupler

Undercarriage	Front and Rear Outriggers					
Counterweight	3.7 mt					
Boom Type	1 PC			VA		
Stick Length	2.20 m (7'3")	2.50 m (8'2")	2.90 m (9'6")	2.20 m (7'3")	2.50 m (8'2")	2.90 m (9'6")
H110 S	✓	✓	✓	✓	✓	✓
H115 S	✓	✓			✓	

Tilt-Rotator TRS14 with CW30 Dedicated Coupler *(continued)*

Undercarriage	Front and Rear Outriggers					
Counterweight	4.2 mt					
Boom Type	1 PC			VA		
Stick Length	2.20 m (7'3")	2.50 m (8'2")	2.90 m (9'6")	2.20 m (7'3")	2.50 m (8'2")	2.90 m (9'6")
H110 S	✓	✓	✓	✓	✓	✓
H115 S	✓	✓			✓	

Tilt-Rotator TRS14 with CW30 Dedicated Coupler *(continued)*

Undercarriage	Front Blade; Rear Outriggers					
Counterweight	3.7 mt					
Boom Type	1 PC			VA		
Stick Length	2.20 m (7'3")	2.50 m (8'2")	2.90 m (9'6")	2.20 m (7'3")	2.50 m (8'2")	2.90 m (9'6")
H110 S	✓	✓	✓	✓	✓	✓
H115 S	✓	✓			✓	

Tilt-Rotator TRS14 with CW30 Dedicated Coupler *(continued)*

Undercarriage	Front Blade; Rear Outriggers					
Counterweight	4.2 mt					
Boom Type	1 PC			VA		
Stick Length	2.20 m (7'3")	2.50 m (8'2")	2.90 m (9'6")	2.20 m (7'3")	2.50 m (8'2")	2.90 m (9'6")
H110 S	✓	✓	✓	✓	✓	✓
H115 S	✓	✓			✓	

Tilt-Rotator TRS14 with CW30 Dedicated Coupler *(continued)*

Undercarriage	Front Outriggers; Rear Blade (Wide U/C)					
Counterweight	3.7 mt					
Boom Type	1 PC			VA		
Stick Length	2.20 m (7'3")	2.50 m (8'2")	2.90 m (9'6")	2.20 m (7'3")	2.50 m (8'2")	2.90 m (9'6")
H110 S	✓	✓	✓	✓	✓	✓
H115 S	✓	✓			✓	

Tilt-Rotator TRS14 with CW30 Dedicated Coupler *(continued)*

Undercarriage	Front Outriggers; Rear Blade (Wide U/C)					
Counterweight	4.2 mt					
Boom Type	1 PC			VA		
Stick Length	2.20 m (7'3")	2.50 m (8'2")	2.90 m (9'6")	2.20 m (7'3")	2.50 m (8'2")	2.90 m (9'6")
H110 S	✓	✓	✓	✓	✓	✓
H115 S	✓	✓			✓	

(continued on next page)

Hammer Technical Specifications

Matching – Wheeled Excavators (continued)

Match
 * Working Range Front Only
 † Allowed Usage on Machine Less Than 50%
 No Match

M318 (continued)

Tilt-Rotator TRS14 with CW30 Dedicated Coupler (continued)

Undercarriage	Front Outriggers; Rear Blade					
Counterweight	3.7 mt					
Boom Type	1 PC			VA		
Stick Length	2.20 m (7'3")	2.50 m (8'2")	2.90 m (9'6")	2.20 m (7'3")	2.50 m (8'2")	2.90 m (9'6")
H110 S	✓	✓	✓	✓	✓	✓
H115 S	✓	✓			✓	

Tilt-Rotator TRS14 with CW30 Dedicated Coupler (continued)

Undercarriage	Front Outriggers; Rear Blade					
Counterweight	4.2 mt					
Boom Type	1 PC			VA		
Stick Length	2.20 m (7'3")	2.50 m (8'2")	2.90 m (9'6")	2.20 m (7'3")	2.50 m (8'2")	2.90 m (9'6")
H110 S	✓	✓	✓	✓	✓	✓
H115 S	✓	✓			✓	

Tilt-Rotator TRS14 with CW30 Dedicated Coupler (continued)

Undercarriage	Rear Blade			
Counterweight	3.7 mt			
Boom Type	1 PC		VA	
Stick Length	2.20 m (7'3")	2.50 m (8'2")	2.20 m (7'3")	2.50 m (8'2")
H110 S	✓	✓	✓	✓
H115 S	✓			

Tilt-Rotator TRS14 with CW30 Dedicated Coupler (continued)

Undercarriage	Rear Blade					
Counterweight	4.2 mt					
Boom Type	1 PC			VA		
Stick Length	2.20 m (7'3")	2.50 m (8'2")	2.90 m (9'6")	2.20 m (7'3")	2.50 m (8'2")	2.90 m (9'6")
H110 S	✓	✓	✓	✓	✓	✓
H115 S	✓	✓			✓	

Tilt-Rotator TRS14 with CW30 Dedicated Coupler (continued)

Undercarriage	Rear Blade (Wide U/C)					
Counterweight	3.7 mt					
Boom Type	1 PC			VA		
Stick Length	2.20 m (7'3")	2.50 m (8'2")	2.90 m (9'6")	2.20 m (7'3")	2.50 m (8'2")	2.90 m (9'6")
H110 S	✓	✓	✓	✓	✓	✓
H115 S	✓	✓			✓	

Tilt-Rotator TRS14 with CW30 Dedicated Coupler (continued)

Undercarriage	Rear Blade (Wide U/C)					
Counterweight	4.2 mt					
Boom Type	1 PC			VA		
Stick Length	2.20 m (7'3")	2.50 m (8'2")	2.90 m (9'6")	2.20 m (7'3")	2.50 m (8'2")	2.90 m (9'6")
H110 S	✓	✓	✓	✓	✓	✓
H115 S	✓	✓			✓	

(continued on next page)

Matching – Wheeled Excavators *(continued)*

Match
 Working Range Front Only
 Allowed Usage on Machine Less Than 50%
 No Match

M318 *(continued)*

Tilt-Rotator TRS14 with S60 Dedicated Coupler

Undercarriage	Front and Rear Outriggers					
Counterweight	3.7 mt					
Boom Type	1 PC			VA		
Stick Length	2.20 m (7'3")	2.50 m (8'2")	2.90 m (9'6")	2.20 m (7'3")	2.50 m (8'2")	2.90 m (9'6")
H110 S	✓	✓	✓	✓	✓	✓
H115 S	✓	✓	✓	✓	✓	✓

Tilt-Rotator TRS14 with S60 Dedicated Coupler *(continued)*

Undercarriage	Front and Rear Outriggers					
Counterweight	4.2 mt					
Boom Type	1 PC			VA		
Stick Length	2.20 m (7'3")	2.50 m (8'2")	2.90 m (9'6")	2.20 m (7'3")	2.50 m (8'2")	2.90 m (9'6")
H110 S	✓	✓	✓	✓	✓	✓
H115 S	✓	✓	✓	✓	✓	✓

Tilt-Rotator TRS14 with S60 Dedicated Coupler *(continued)*

Undercarriage	Front Blade; Rear Outriggers					
Counterweight	3.7 mt					
Boom Type	1 PC			VA		
Stick Length	2.20 m (7'3")	2.50 m (8'2")	2.90 m (9'6")	2.20 m (7'3")	2.50 m (8'2")	2.90 m (9'6")
H110 S	✓	✓	✓	✓	✓	✓
H115 S	✓	✓	✓	✓	✓	✓

Tilt-Rotator TRS14 with S60 Dedicated Coupler *(continued)*

Undercarriage	Front Blade; Rear Outriggers					
Counterweight	4.2 mt					
Boom Type	1 PC			VA		
Stick Length	2.20 m (7'3")	2.50 m (8'2")	2.90 m (9'6")	2.20 m (7'3")	2.50 m (8'2")	2.90 m (9'6")
H110 S	✓	✓	✓	✓	✓	✓
H115 S	✓	✓	✓	✓	✓	✓

Tilt-Rotator TRS14 with S60 Dedicated Coupler *(continued)*

Undercarriage	Front Outriggers; Rear Blade (Wide U/C)					
Counterweight	3.7 mt					
Boom Type	1 PC			VA		
Stick Length	2.20 m (7'3")	2.50 m (8'2")	2.90 m (9'6")	2.20 m (7'3")	2.50 m (8'2")	2.90 m (9'6")
H110 S	✓	✓	✓	✓	✓	✓
H115 S	✓	✓	✓	✓	✓	✓

Tilt-Rotator TRS14 with S60 Dedicated Coupler *(continued)*

Undercarriage	Front Outriggers; Rear Blade (Wide U/C)					
Counterweight	4.2 mt					
Boom Type	1 PC			VA		
Stick Length	2.20 m (7'3")	2.50 m (8'2")	2.90 m (9'6")	2.20 m (7'3")	2.50 m (8'2")	2.90 m (9'6")
H110 S	✓	✓	✓	✓	✓	✓
H115 S	✓	✓	✓	✓	✓	✓

(continued on next page)

Hammer Technical Specifications

Matching – Wheeled Excavators (continued)

Match
 Working Range Front Only
 Allowed Usage on Machine Less Than 50%
 No Match

M318 (continued)

Tilt-Rotator TRS14 with S60 Dedicated Coupler (continued)

Undercarriage	Front Outriggers; Rear Blade					
Counterweight	3.7 mt					
Boom Type	1 PC			VA		
Stick Length	2.20 m (7'3")	2.50 m (8'2")	2.90 m (9'6")	2.20 m (7'3")	2.50 m (8'2")	2.90 m (9'6")
H110 S	✓	✓	✓	✓	✓	✓
H115 S	✓	✓	✓	✓	✓	✓

Tilt-Rotator TRS14 with S60 Dedicated Coupler (continued)

Undercarriage	Front Outriggers; Rear Blade					
Counterweight	4.2 mt					
Boom Type	1 PC			VA		
Stick Length	2.20 m (7'3")	2.50 m (8'2")	2.90 m (9'6")	2.20 m (7'3")	2.50 m (8'2")	2.90 m (9'6")
H110 S	✓	✓	✓	✓	✓	✓
H115 S	✓	✓	✓	✓	✓	✓

Tilt-Rotator TRS14 with S60 Dedicated Coupler (continued)

Undercarriage	Rear Blade					
Counterweight	3.7 mt					
Boom Type	1 PC			VA		
Stick Length	2.20 m (7'3")	2.50 m (8'2")	2.90 m (9'6")	2.20 m (7'3")	2.50 m (8'2")	2.90 m (9'6")
H110 S	✓	✓	✓	✓	✓	✓
H115 S	✓	✓	✓	✓	✓	✓

Tilt-Rotator TRS14 with S60 Dedicated Coupler (continued)

Undercarriage	Rear Blade					
Counterweight	4.2 mt					
Boom Type	1 PC			VA		
Stick Length	2.20 m (7'3")	2.50 m (8'2")	2.90 m (9'6")	2.20 m (7'3")	2.50 m (8'2")	2.90 m (9'6")
H110 S	✓	✓	✓	✓	✓	✓
H115 S	✓	✓	✓	✓	✓	✓

Tilt-Rotator TRS14 with S60 Dedicated Coupler (continued)

Undercarriage	Rear Blade (Wide U/C)					
Counterweight	3.7 mt					
Boom Type	1 PC			VA		
Stick Length	2.20 m (7'3")	2.50 m (8'2")	2.90 m (9'6")	2.20 m (7'3")	2.50 m (8'2")	2.90 m (9'6")
H110 S	✓	✓	✓	✓	✓	✓
H115 S	✓	✓	✓	✓	✓	✓

Tilt-Rotator TRS14 with S60 Dedicated Coupler (continued)

Undercarriage	Rear Blade (Wide U/C)					
Counterweight	4.2 mt					
Boom Type	1 PC			VA		
Stick Length	2.20 m (7'3")	2.50 m (8'2")	2.90 m (9'6")	2.20 m (7'3")	2.50 m (8'2")	2.90 m (9'6")
H110 S	✓	✓	✓	✓	✓	✓
H115 S	✓	✓	✓	✓	✓	✓

(continued on next page)

Matching – Wheeled Excavators (continued)

Match
 Working Range Front Only
 Allowed Usage on Machine Less Than 50%
 No Match

M318 (continued)

S60 – Tilt-Rotator TRS14 – S60

Undercarriage	Front and Rear Outriggers					
Counterweight	3.7 mt					
Boom Type	1 PC			VA		
Stick Length	2.20 m (7'3")	2.50 m (8'2")	2.90 m (9'6")	2.20 m (7'3")	2.50 m (8'2")	2.90 m (9'6")
H110 S	✓	✓	✓	✓	✓	✓
H115 S	✓	✓	✓	✓	✓	✓

S60 – Tilt-Rotator TRS14 – S60 (continued)

Undercarriage	Front and Rear Outriggers					
Counterweight	4.2 mt					
Boom Type	1 PC			VA		
Stick Length	2.20 m (7'3")	2.50 m (8'2")	2.90 m (9'6")	2.20 m (7'3")	2.50 m (8'2")	2.90 m (9'6")
H110 S	✓	✓	✓	✓	✓	✓
H115 S	✓	✓	✓	✓	✓	✓

S60 – Tilt-Rotator TRS14 – S60 (continued)

Undercarriage	Front Blade; Rear Outriggers					
Counterweight	3.7 mt					
Boom Type	1 PC			VA		
Stick Length	2.20 m (7'3")	2.50 m (8'2")	2.90 m (9'6")	2.20 m (7'3")	2.50 m (8'2")	2.90 m (9'6")
H110 S	✓	✓	✓	✓	✓	✓
H115 S	✓	✓	✓	✓	✓	✓

S60 – Tilt-Rotator TRS14 – S60 (continued)

Undercarriage	Front Blade; Rear Outriggers					
Counterweight	4.2 mt					
Boom Type	1 PC			VA		
Stick Length	2.20 m (7'3")	2.50 m (8'2")	2.90 m (9'6")	2.20 m (7'3")	2.50 m (8'2")	2.90 m (9'6")
H110 S	✓	✓	✓	✓	✓	✓
H115 S	✓	✓	✓	✓	✓	✓

S60 – Tilt-Rotator TRS14 – S60 (continued)

Undercarriage	Front Outriggers; Rear Blade (Wide U/C)					
Counterweight	3.7 mt					
Boom Type	1 PC			VA		
Stick Length	2.20 m (7'3")	2.50 m (8'2")	2.90 m (9'6")	2.20 m (7'3")	2.50 m (8'2")	2.90 m (9'6")
H110 S	✓	✓	✓	✓	✓	✓
H115 S	✓	✓	✓	✓	✓	✓

S60 – Tilt-Rotator TRS14 – S60 (continued)

Undercarriage	Front Outriggers; Rear Blade (Wide U/C)					
Counterweight	4.2 mt					
Boom Type	1 PC			VA		
Stick Length	2.20 m (7'3")	2.50 m (8'2")	2.90 m (9'6")	2.20 m (7'3")	2.50 m (8'2")	2.90 m (9'6")
H110 S	✓	✓	✓	✓	✓	✓
H115 S	✓	✓	✓	✓	✓	✓

(continued on next page)

Hammer Technical Specifications

Matching – Wheeled Excavators (continued)

Match
 Working Range Front Only
 Allowed Usage on Machine Less Than 50%
 No Match

M318 (continued)

S60 – Tilt-Rotator TRS14 – S60 (continued)

Undercarriage	Front Outriggers; Rear Blade					
Counterweight	3.7 mt					
Boom Type	1 PC			VA		
Stick Length	2.20 m (7'3")	2.50 m (8'2")	2.90 m (9'6")	2.20 m (7'3")	2.50 m (8'2")	2.90 m (9'6")
H110 S	✓	✓	✓	✓	✓	✓
H115 S	✓	✓	✓	✓	✓	✓

S60 – Tilt-Rotator TRS14 – S60 (continued)

Undercarriage	Front Outriggers; Rear Blade					
Counterweight	4.2 mt					
Boom Type	1 PC			VA		
Stick Length	2.20 m (7'3")	2.50 m (8'2")	2.90 m (9'6")	2.20 m (7'3")	2.50 m (8'2")	2.90 m (9'6")
H110 S	✓	✓	✓	✓	✓	✓
H115 S	✓	✓	✓	✓	✓	✓

S60 – Tilt-Rotator TRS14 – S60 (continued)

Undercarriage	Rear Blade					
Counterweight	3.7 mt					
Boom Type	1 PC			VA		
Stick Length	2.20 m (7'3")	2.50 m (8'2")	2.90 m (9'6")	2.20 m (7'3")	2.50 m (8'2")	2.90 m (9'6")
H110 S	✓	✓	✓	✓	✓	✓
H115 S	✓	✓	✓	✓	✓	✓

S60 – Tilt-Rotator TRS14 – S60 (continued)

Undercarriage	Rear Blade					
Counterweight	4.2 mt					
Boom Type	1 PC			VA		
Stick Length	2.20 m (7'3")	2.50 m (8'2")	2.90 m (9'6")	2.20 m (7'3")	2.50 m (8'2")	2.90 m (9'6")
H110 S	✓	✓	✓	✓	✓	✓
H115 S	✓	✓	✓	✓	✓	✓

S60 – Tilt-Rotator TRS14 – S60 (continued)

Undercarriage	Rear Blade (Wide U/C)					
Counterweight	3.7 mt					
Boom Type	1 PC			VA		
Stick Length	2.20 m (7'3")	2.50 m (8'2")	2.90 m (9'6")	2.20 m (7'3")	2.50 m (8'2")	2.90 m (9'6")
H110 S	✓	✓	✓	✓	✓	✓
H115 S	✓	✓	✓	✓	✓	✓

S60 – Tilt-Rotator TRS14 – S60 (continued)

Undercarriage	Rear Blade (Wide U/C)					
Counterweight	4.2 mt					
Boom Type	1 PC			VA		
Stick Length	2.20 m (7'3")	2.50 m (8'2")	2.90 m (9'6")	2.20 m (7'3")	2.50 m (8'2")	2.90 m (9'6")
H110 S	✓	✓	✓	✓	✓	✓
H115 S	✓	✓	✓	✓	✓	✓

(continued on next page)

Matching – Wheeled Excavators *(continued)*

Match
 * Working Range Front Only
 † Allowed Usage on Machine Less Than 50%
 No Match

M318 *(continued)*

Tilt-Rotator TRS14 with HCS60 Dedicated Coupler

Undercarriage	Front and Rear Outriggers					
Counterweight	3.7 mt					
Boom Type	1 PC			VA		
Stick Length	2.20 m (7'3")	2.50 m (8'2")	2.90 m (9'6")	2.20 m (7'3")	2.50 m (8'2")	2.90 m (9'6")
H110 S	✓	✓	✓	✓	✓	✓
H115 S	✓	✓	✓	✓	✓	✓

Tilt-Rotator TRS14 with HCS60 Dedicated Coupler *(continued)*

Undercarriage	Front and Rear Outriggers					
Counterweight	4.2 mt					
Boom Type	1 PC			VA		
Stick Length	2.20 m (7'3")	2.50 m (8'2")	2.90 m (9'6")	2.20 m (7'3")	2.50 m (8'2")	2.90 m (9'6")
H110 S	✓	✓	✓	✓	✓	✓
H115 S	✓	✓	✓	✓	✓	✓

Tilt-Rotator TRS14 with HCS60 Dedicated Coupler *(continued)*

Undercarriage	Front Blade; Rear Outriggers					
Counterweight	3.7 mt					
Boom Type	1 PC			VA		
Stick Length	2.20 m (7'3")	2.50 m (8'2")	2.90 m (9'6")	2.20 m (7'3")	2.50 m (8'2")	2.90 m (9'6")
H110 S	✓	✓	✓	✓	✓	✓
H115 S	✓	✓	✓	✓	✓	✓

Tilt-Rotator TRS14 with HCS60 Dedicated Coupler *(continued)*

Undercarriage	Front Blade; Rear Outriggers					
Counterweight	4.2 mt					
Boom Type	1 PC			VA		
Stick Length	2.20 m (7'3")	2.50 m (8'2")	2.90 m (9'6")	2.20 m (7'3")	2.50 m (8'2")	2.90 m (9'6")
H110 S	✓	✓	✓	✓	✓	✓
H115 S	✓	✓	✓	✓	✓	✓

Tilt-Rotator TRS14 with HCS60 Dedicated Coupler *(continued)*

Undercarriage	Front Outriggers; Rear Blade (Wide U/C)					
Counterweight	3.7 mt					
Boom Type	1 PC			VA		
Stick Length	2.20 m (7'3")	2.50 m (8'2")	2.90 m (9'6")	2.20 m (7'3")	2.50 m (8'2")	2.90 m (9'6")
H110 S	✓	✓	✓	✓	✓	✓
H115 S	✓	✓	✓	✓	✓	✓

Tilt-Rotator TRS14 with HCS60 Dedicated Coupler *(continued)*

Undercarriage	Front Outriggers; Rear Blade (Wide U/C)					
Counterweight	4.2 mt					
Boom Type	1 PC			VA		
Stick Length	2.20 m (7'3")	2.50 m (8'2")	2.90 m (9'6")	2.20 m (7'3")	2.50 m (8'2")	2.90 m (9'6")
H110 S	✓	✓	✓	✓	✓	✓
H115 S	✓	✓	✓	✓	✓	✓

(continued on next page)

Hammer Technical Specifications

Matching – Wheeled Excavators *(continued)*

Match
 * Working Range Front Only
 † Allowed Usage on Machine Less Than 50%
 No Match

M318 *(continued)*

Tilt-Rotator TRS14 with HCS60 Dedicated Coupler *(continued)*

Undercarriage	Front Outriggers; Rear Blade					
Counterweight	3.7 mt					
Boom Type	1 PC			VA		
Stick Length	2.20 m (7'3")	2.50 m (8'2")	2.90 m (9'6")	2.20 m (7'3")	2.50 m (8'2")	2.90 m (9'6")
H110 S	✓	✓	✓	✓	✓	✓
H115 S	✓	✓	✓	✓	✓	✓

Tilt-Rotator TRS14 with HCS60 Dedicated Coupler *(continued)*

Undercarriage	Front Outriggers; Rear Blade					
Counterweight	4.2 mt					
Boom Type	1 PC			VA		
Stick Length	2.20 m (7'3")	2.50 m (8'2")	2.90 m (9'6")	2.20 m (7'3")	2.50 m (8'2")	2.90 m (9'6")
H110 S	✓	✓	✓	✓	✓	✓
H115 S	✓	✓	✓	✓	✓	✓

Tilt-Rotator TRS14 with HCS60 Dedicated Coupler *(continued)*

Undercarriage	Rear Blade					
Counterweight	3.7 mt					
Boom Type	1 PC			VA		
Stick Length	2.20 m (7'3")	2.50 m (8'2")	2.90 m (9'6")	2.20 m (7'3")	2.50 m (8'2")	2.90 m (9'6")
H110 S	✓	✓	✓	✓	✓	✓
H115 S	✓	✓	✓	✓	✓	✓

Tilt-Rotator TRS14 with HCS60 Dedicated Coupler *(continued)*

Undercarriage	Rear Blade					
Counterweight	4.2 mt					
Boom Type	1 PC			VA		
Stick Length	2.20 m (7'3")	2.50 m (8'2")	2.90 m (9'6")	2.20 m (7'3")	2.50 m (8'2")	2.90 m (9'6")
H110 S	✓	✓	✓	✓	✓	✓
H115 S	✓	✓	✓	✓	✓	✓

Tilt-Rotator TRS14 with HCS60 Dedicated Coupler *(continued)*

Undercarriage	Rear Blade (Wide U/C)					
Counterweight	3.7 mt					
Boom Type	1 PC			VA		
Stick Length	2.20 m (7'3")	2.50 m (8'2")	2.90 m (9'6")	2.20 m (7'3")	2.50 m (8'2")	2.90 m (9'6")
H110 S	✓	✓	✓	✓	✓	✓
H115 S	✓	✓	✓	✓	✓	✓

Tilt-Rotator TRS14 with HCS60 Dedicated Coupler *(continued)*

Undercarriage	Rear Blade (Wide U/C)					
Counterweight	4.2 mt					
Boom Type	1 PC			VA		
Stick Length	2.20 m (7'3")	2.50 m (8'2")	2.90 m (9'6")	2.20 m (7'3")	2.50 m (8'2")	2.90 m (9'6")
H110 S	✓	✓	✓	✓	✓	✓
H115 S	✓	✓	✓	✓	✓	✓

(continued on next page)

Matching – Wheeled Excavators *(continued)*

Match
 Working Range Front Only
 Allowed Usage on Machine Less Than 50%
 No Match

M318 *(continued)*

HCS60 – Tilt-Rotator TRS14 – HCS60

Undercarriage	Front and Rear Outriggers					
Counterweight	3.7 mt					
Boom Type	1 PC			VA		
Stick Length	2.20 m (7'3")	2.50 m (8'2")	2.90 m (9'6")	2.20 m (7'3")	2.50 m (8'2")	2.90 m (9'6")
H110 S	✓	✓	✓	✓	✓	✓
H115 S	✓	✓		✓	✓	

HCS60 – Tilt-Rotator TRS14 – HCS60 *(continued)*

Undercarriage	Front and Rear Outriggers					
Counterweight	4.2 mt					
Boom Type	1 PC			VA		
Stick Length	2.20 m (7'3")	2.50 m (8'2")	2.90 m (9'6")	2.20 m (7'3")	2.50 m (8'2")	2.90 m (9'6")
H110 S	✓	✓	✓	✓	✓	✓
H115 S	✓	✓		✓	✓	

HCS60 – Tilt-Rotator TRS14 – HCS60 *(continued)*

Undercarriage	Front Blade; Rear Outriggers					
Counterweight	3.7 mt					
Boom Type	1 PC			VA		
Stick Length	2.20 m (7'3")	2.50 m (8'2")	2.90 m (9'6")	2.20 m (7'3")	2.50 m (8'2")	2.90 m (9'6")
H110 S	✓	✓	✓	✓	✓	✓
H115 S	✓	✓		✓	✓	

HCS60 – Tilt-Rotator TRS14 – HCS60 *(continued)*

Undercarriage	Front Blade; Rear Outriggers					
Counterweight	4.2 mt					
Boom Type	1 PC			VA		
Stick Length	2.20 m (7'3")	2.50 m (8'2")	2.90 m (9'6")	2.20 m (7'3")	2.50 m (8'2")	2.90 m (9'6")
H110 S	✓	✓	✓	✓	✓	✓
H115 S	✓	✓		✓	✓	

HCS60 – Tilt-Rotator TRS14 – HCS60 *(continued)*

Undercarriage	Front Outriggers; Rear Blade (Wide U/C)					
Counterweight	3.7 mt					
Boom Type	1 PC			VA		
Stick Length	2.20 m (7'3")	2.50 m (8'2")	2.90 m (9'6")	2.20 m (7'3")	2.50 m (8'2")	2.90 m (9'6")
H110 S	✓	✓	✓	✓	✓	✓
H115 S	✓	✓		✓	✓	

HCS60 – Tilt-Rotator TRS14 – HCS60 *(continued)*

Undercarriage	Front Outriggers; Rear Blade (Wide U/C)					
Counterweight	4.2 mt					
Boom Type	1 PC			VA		
Stick Length	2.20 m (7'3")	2.50 m (8'2")	2.90 m (9'6")	2.20 m (7'3")	2.50 m (8'2")	2.90 m (9'6")
H110 S	✓	✓	✓	✓	✓	✓
H115 S	✓	✓		✓	✓	

(continued on next page)

Hammer Technical Specifications

Matching – Wheeled Excavators (continued)

Match
 Working Range Front Only
 Allowed Usage on Machine Less Than 50%
 No Match

M318 (continued)

HCS60 – Tilt-Rotator TRS14 – HCS60 (continued)

Undercarriage	Front Outriggers; Rear Blade					
Counterweight	3.7 mt					
Boom Type	1 PC			VA		
Stick Length	2.20 m (7'3")	2.50 m (8'2")	2.90 m (9'6")	2.20 m (7'3")	2.50 m (8'2")	2.90 m (9'6")
H110 S	✓	✓	✓	✓	✓	✓
H115 S	✓	✓		✓	✓	

HCS60 – Tilt-Rotator TRS14 – HCS60 (continued)

Undercarriage	Front Outriggers; Rear Blade					
Counterweight	4.2 mt					
Boom Type	1 PC			VA		
Stick Length	2.20 m (7'3")	2.50 m (8'2")	2.90 m (9'6")	2.20 m (7'3")	2.50 m (8'2")	2.90 m (9'6")
H110 S	✓	✓	✓	✓	✓	✓
H115 S	✓	✓		✓	✓	

HCS60 – Tilt-Rotator TRS14 – HCS60 (continued)

Undercarriage	Rear Blade			
Counterweight	3.7 mt			
Boom Type	1 PC		VA	
Stick Length	2.20 m (7'3")	2.50 m (8'2")	2.20 m (7'3")	2.50 m (8'2")
H110 S	✓	✓	✓	✓
H115 S	✓			

HCS60 – Tilt-Rotator TRS14 – HCS60 (continued)

Undercarriage	Rear Blade					
Counterweight	4.2 mt					
Boom Type	1 PC			VA		
Stick Length	2.20 m (7'3")	2.50 m (8'2")	2.90 m (9'6")	2.20 m (7'3")	2.50 m (8'2")	2.90 m (9'6")
H110 S	✓	✓	✓	✓	✓	✓
H115 S	✓	✓		✓	✓	

HCS60 – Tilt-Rotator TRS14 – HCS60 (continued)

Undercarriage	Rear Blade (Wide U/C)					
Counterweight	3.7 mt					
Boom Type	1 PC			VA		
Stick Length	2.20 m (7'3")	2.50 m (8'2")	2.90 m (9'6")	2.20 m (7'3")	2.50 m (8'2")	2.90 m (9'6")
H110 S	✓	✓	✓	✓	✓	✓
H115 S	✓	✓		✓	✓	

HCS60 – Tilt-Rotator TRS14 – HCS60 (continued)

Undercarriage	Rear Blade (Wide U/C)					
Counterweight	4.2 mt					
Boom Type	1 PC			VA		
Stick Length	2.20 m (7'3")	2.50 m (8'2")	2.90 m (9'6")	2.20 m (7'3")	2.50 m (8'2")	2.90 m (9'6")
H110 S	✓	✓	✓	✓	✓	✓
H115 S	✓	✓		✓	✓	

(continued on next page)

Matching – Wheeled Excavators (continued)

Match
 Working Range Front Only
 Allowed Usage on Machine Less Than 50%
 No Match

M318 (continued)

HCS65 – Tilt-Rotator TRS14 – HCS65

Undercarriage	Front and Rear Outriggers							
Counterweight	3.7 mt				4.2 mt			
Boom Type	1 PC		VA		1 PC		VA	
Stick Length	2.20 m (7'3")	2.50 m (8'2")	2.20 m (7'3")	2.50 m (8'2")	2.20 m (7'3")	2.50 m (8'2")	2.20 m (7'3")	2.50 m (8'2")
H110 S	✓	✓	✓	✓	✓	✓	✓	✓
H115 S	✓	✓	✓	✓	✓	✓	✓	✓

HCS65 – Tilt-Rotator TRS14 – HCS65 (continued)

Undercarriage	Front Blade; Rear Outriggers							
Counterweight	3.7 mt				4.2 mt			
Boom Type	1 PC		VA		1 PC		VA	
Stick Length	2.20 m (7'3")	2.50 m (8'2")	2.20 m (7'3")	2.50 m (8'2")	2.20 m (7'3")	2.50 m (8'2")	2.20 m (7'3")	2.50 m (8'2")
H110 S	✓	✓	✓	✓	✓	✓	✓	✓
H115 S	✓	✓	✓	✓	✓	✓	✓	✓

HCS65 – Tilt-Rotator TRS14 – HCS65 (continued)

Undercarriage	Front Outriggers; Rear Blade (Wide U/C)							
Counterweight	3.7 mt				4.2 mt			
Boom Type	1 PC		VA		1 PC		VA	
Stick Length	2.20 m (7'3")	2.50 m (8'2")	2.20 m (7'3")	2.50 m (8'2")	2.20 m (7'3")	2.50 m (8'2")	2.20 m (7'3")	2.50 m (8'2")
H110 S	✓	✓	✓	✓	✓	✓	✓	✓
H115 S	✓	✓	✓	✓	✓	✓	✓	✓

HCS65 – Tilt-Rotator TRS14 – HCS65 (continued)

Undercarriage	Front Outriggers; Rear Blade							
Counterweight	3.7 mt				4.2 mt			
Boom Type	1 PC		VA		1 PC		VA	
Stick Length	2.20 m (7'3")	2.50 m (8'2")	2.20 m (7'3")	2.50 m (8'2")	2.20 m (7'3")	2.50 m (8'2")	2.20 m (7'3")	2.50 m (8'2")
H110 S	✓	✓	✓	✓	✓	✓	✓	✓
H115 S	✓	✓	✓	✓	✓	✓	✓	✓

HCS65 – Tilt-Rotator TRS14 – HCS65 (continued)

Undercarriage	Rear Blade		
Counterweight	4.2 mt		
Boom Type	1 PC	VA	
Stick Length	2.20 m (7'3")	2.50 m (8'2")	2.20 m (7'3")
H110 S	✓	✓	✓
H115 S	✓		

HCS65 – Tilt-Rotator TRS14 – HCS65 (continued)

Undercarriage	Rear Blade (Wide U/C)							
Counterweight	3.7 mt				4.2 mt			
Boom Type	1 PC		VA		1 PC		VA	
Stick Length	2.20 m (7'3")	2.50 m (8'2")	2.20 m (7'3")	2.50 m (8'2")	2.20 m (7'3")	2.50 m (8'2")	2.20 m (7'3")	2.50 m (8'2")
H110 S	✓	✓	✓	✓	✓	✓	✓	✓
H115 S	✓	✓	✓		✓	✓	✓	✓

(continued on next page)

Hammer Technical Specifications

Matching – Wheeled Excavators (continued)

Match
 Working Range Front Only
 Allowed Usage on Machine Less Than 50%
 No Match

M319

Pin-on

Undercarriage	Front and Rear Outriggers			Front Blade; Rear Outriggers			Front Outriggers; Rear Blade (Wide U/C)		
Counterweight	5.0 mt			5.0 mt			5.0 mt		
Boom Type	VA			VA			VA		
Stick Length	2.20 m (7'3")	2.50 m (8'2")	2.90 m (9'6")	2.20 m (7'3")	2.50 m (8'2")	2.90 m (9'6")	2.20 m (7'3")	2.50 m (8'2")	2.90 m (9'6")
H110 S	✓	✓	✓	✓	✓	✓	✓	✓	✓
H115 S	✓	✓	✓	✓	✓	✓	✓	✓	✓
H120 S		✓	✓		✓	✓		✓	✓

Pin-on (continued)

Undercarriage	Front Outriggers; Rear Blade			Rear Blade			Rear Blade (Wide U/C)		
Counterweight	5.0 mt			5.0 mt			5.0 mt		
Boom Type	VA			VA			VA		
Stick Length	2.20 m (7'3")	2.50 m (8'2")	2.90 m (9'6")	2.20 m (7'3")	2.50 m (8'2")	2.90 m (9'6")	2.20 m (7'3")	2.50 m (8'2")	2.90 m (9'6")
H110 S	✓	✓	✓	✓	✓	✓	✓	✓	✓
H115 S	✓	✓	✓	✓	✓	✓	✓	✓	✓
H120 S		✓	✓		✓	✓		✓	✓

Cat Pin Grabber Coupler

Undercarriage	Front and Rear Outriggers			Front Blade; Rear Outriggers			Front Outriggers; Rear Blade (Wide U/C)		
Counterweight	5.0 mt			5.0 mt			5.0 mt		
Boom Type	VA			VA			VA		
Stick Length	2.20 m (7'3")	2.50 m (8'2")	2.90 m (9'6")	2.20 m (7'3")	2.50 m (8'2")	2.90 m (9'6")	2.20 m (7'3")	2.50 m (8'2")	2.90 m (9'6")
H110 S	✓	✓	✓	✓	✓	✓	✓	✓	✓
H115 S	✓	✓	✓	✓	✓	✓	✓	✓	✓

Cat Pin Grabber Coupler (continued)

Undercarriage	Front Outriggers; Rear Blade			Rear Blade			Rear Blade (Wide U/C)		
Counterweight	5.0 mt			5.0 mt			5.0 mt		
Boom Type	VA			VA			VA		
Stick Length	2.20 m (7'3")	2.50 m (8'2")	2.90 m (9'6")	2.20 m (7'3")	2.50 m (8'2")	2.90 m (9'6")	2.20 m (7'3")	2.50 m (8'2")	2.90 m (9'6")
H110 S	✓	✓	✓	✓	✓	✓	✓	✓	✓
H115 S	✓	✓	✓	✓	✓	✓	✓	✓	✓

CW-30 S Dedicated Coupler

Undercarriage	Front and Rear Outriggers			Front Blade; Rear Outriggers			Front Outriggers; Rear Blade (Wide U/C)		
Counterweight	5.0 mt			5.0 mt			5.0 mt		
Boom Type	VA			VA			VA		
Stick Length	2.20 m (7'3")	2.50 m (8'2")	2.90 m (9'6")	2.20 m (7'3")	2.50 m (8'2")	2.90 m (9'6")	2.20 m (7'3")	2.50 m (8'2")	2.90 m (9'6")
H110 S	✓	✓	✓	✓	✓	✓	✓	✓	✓
H115 S	✓	✓	✓	✓	✓	✓	✓	✓	✓

CW-30 S Dedicated Coupler (continued)

Undercarriage	Front Outriggers; Rear Blade			Rear Blade			Rear Blade (Wide U/C)		
Counterweight	5.0 mt			5.0 mt			5.0 mt		
Boom Type	VA			VA			VA		
Stick Length	2.20 m (7'3")	2.50 m (8'2")	2.90 m (9'6")	2.20 m (7'3")	2.50 m (8'2")	2.90 m (9'6")	2.20 m (7'3")	2.50 m (8'2")	2.90 m (9'6")
H110 S	✓	✓	✓	✓	✓	✓	✓	✓	✓
H115 S	✓	✓	✓	✓	✓	✓	✓	✓	✓

(continued on next page)

Matching – Wheeled Excavators (continued)

Match
 Working Range Front Only
 Allowed Usage on Machine Less Than 50%
 No Match

M319 (continued)

CW-30 Dedicated Coupler

Undercarriage	Front and Rear Outriggers			Front Blade; Rear Outriggers			Front Outriggers; Rear Blade (Wide U/C)		
Counterweight	5.0 mt			5.0 mt			5.0 mt		
Boom Type	VA			VA			VA		
Stick Length	2.20 m (7'3")	2.50 m (8'2")	2.90 m (9'6")	2.20 m (7'3")	2.50 m (8'2")	2.90 m (9'6")	2.20 m (7'3")	2.50 m (8'2")	2.90 m (9'6")
H110 S	✓	✓	✓	✓	✓	✓	✓	✓	✓
H115 S	✓	✓	✓	✓	✓	✓	✓	✓	✓

CW-30 Dedicated Coupler (continued)

Undercarriage	Front Outriggers; Rear Blade			Rear Blade			Rear Blade (Wide U/C)		
Counterweight	5.0 mt			5.0 mt			5.0 mt		
Boom Type	VA			VA			VA		
Stick Length	2.20 m (7'3")	2.50 m (8'2")	2.90 m (9'6")	2.20 m (7'3")	2.50 m (8'2")	2.90 m (9'6")	2.20 m (7'3")	2.50 m (8'2")	2.90 m (9'6")
H110 S	✓	✓	✓	✓	✓	✓	✓	✓	✓
H115 S	✓	✓	✓	✓	✓	✓	✓	✓	✓

S60 Dedicated Coupler

Undercarriage	Front Blade; Rear Outriggers			Front Outriggers; Rear Blade (Wide U/C)			Front Outriggers; Rear Blade		
Counterweight	5.0 mt			5.0 mt			5.0 mt		
Boom Type	VA			VA			VA		
Stick Length	2.20 m (7'3")	2.50 m (8'2")	2.90 m (9'6")	2.20 m (7'3")	2.50 m (8'2")	2.90 m (9'6")	2.20 m (7'3")	2.50 m (8'2")	2.90 m (9'6")
H110 S	✓	✓	✓	✓	✓	✓	✓	✓	✓
H115 S	✓	✓	✓	✓	✓	✓	✓	✓	✓

S60 Dedicated Coupler (continued)

Undercarriage	Rear Blade			Rear Blade (Wide U/C)		
Counterweight	5.0 mt			5.0 mt		
Boom Type	VA			VA		
Stick Length	2.20 m (7'3")	2.50 m (8'2")	2.90 m (9'6")	2.20 m (7'3")	2.50 m (8'2")	2.90 m (9'6")
H110 S	✓	✓	✓	✓	✓	✓
H115 S	✓	✓	✓	✓	✓	✓

HCS60 Dedicated Coupler

Undercarriage	Front and Rear Outriggers			Front Blade; Rear Outriggers			Front Outriggers; Rear Blade (Wide U/C)		
Counterweight	5.0 mt			5.0 mt			5.0 mt		
Boom Type	VA			VA			VA		
Stick Length	2.20 m (7'3")	2.50 m (8'2")	2.90 m (9'6")	2.20 m (7'3")	2.50 m (8'2")	2.90 m (9'6")	2.20 m (7'3")	2.50 m (8'2")	2.90 m (9'6")
H110 S	✓	✓	✓	✓	✓	✓	✓	✓	✓
H115 S	✓	✓	✓	✓	✓	✓	✓	✓	✓

HCS60 Dedicated Coupler (continued)

Undercarriage	Front Outriggers; Rear Blade			Rear Blade			Rear Blade (Wide U/C)		
Counterweight	5.0 mt			5.0 mt			5.0 mt		
Boom Type	VA			VA			VA		
Stick Length	2.20 m (7'3")	2.50 m (8'2")	2.90 m (9'6")	2.20 m (7'3")	2.50 m (8'2")	2.90 m (9'6")	2.20 m (7'3")	2.50 m (8'2")	2.90 m (9'6")
H110 S	✓	✓	✓	✓	✓	✓	✓	✓	✓
H115 S	✓	✓	✓	✓	✓	✓	✓	✓	✓

(continued on next page)

Hammer Technical Specifications

Matching – Wheeled Excavators (continued)

Match
 Working Range Front Only
 Allowed Usage on Machine Less Than 50%
 No Match

M319 (continued)

HCS65 Dedicated Coupler

Undercarriage	Front and Rear Outriggers			Front Blade; Rear Outriggers			Front Outriggers; Rear Blade (Wide U/C)		
Counterweight	5.0 mt			5.0 mt			5.0 mt		
Boom Type	VA			VA			VA		
Stick Length	2.20 m (7'3")	2.50 m (8'2")	2.90 m (9'6")	2.20 m (7'3")	2.50 m (8'2")	2.90 m (9'6")	2.20 m (7'3")	2.50 m (8'2")	2.90 m (9'6")
H110 S	✓	✓	✓	✓	✓	✓	✓	✓	✓
H115 S	✓	✓	✓	✓	✓	✓	✓	✓	✓

HCS65 Dedicated Coupler (continued)

Undercarriage	Front Outriggers; Rear Blade			Rear Blade			Rear Blade (Wide U/C)		
Counterweight	5.0 mt			5.0 mt			5.0 mt		
Boom Type	VA			VA			VA		
Stick Length	2.20 m (7'3")	2.50 m (8'2")	2.90 m (9'6")	2.20 m (7'3")	2.50 m (8'2")	2.90 m (9'6")	2.20 m (7'3")	2.50 m (8'2")	2.90 m (9'6")
H110 S	✓	✓	✓	✓	✓	✓	✓	✓	✓
H115 S	✓	✓	✓	✓	✓	✓	✓	✓	✓

CW30 – Tilt-Rotator TRS14 – CW30

Undercarriage	Front and Rear Outriggers							
Counterweight	3.7 mt				4.2 mt			
Boom Type	1 PC		VA		1 PC		VA	
Stick Length	2.20 m (7'3")	2.50 m (8'2")	2.20 m (7'3")	2.50 m (8'2")	2.20 m (7'3")	2.50 m (8'2")	2.20 m (7'3")	2.50 m (8'2")
H110 S	✓	✓	✓	✓	✓	✓	✓	✓
H115 S	✓				✓			

CW30 – Tilt-Rotator TRS14 – CW30 (continued)

Undercarriage	Front Blade; Rear Outriggers							
Counterweight	3.7 mt				4.2 mt			
Boom Type	1 PC		VA		1 PC		VA	
Stick Length	2.20 m (7'3")	2.50 m (8'2")	2.20 m (7'3")	2.50 m (8'2")	2.20 m (7'3")	2.50 m (8'2")	2.20 m (7'3")	2.50 m (8'2")
H110 S	✓	✓	✓	✓	✓	✓	✓	✓
H115 S	✓				✓			

CW30 – Tilt-Rotator TRS14 – CW30 (continued)

Undercarriage	Front Outriggers; Rear Blade (Wide U/C)							
Counterweight	3.7 mt				4.2 mt			
Boom Type	1 PC		VA		1 PC		VA	
Stick Length	2.20 m (7'3")	2.50 m (8'2")	2.20 m (7'3")	2.50 m (8'2")	2.20 m (7'3")	2.50 m (8'2")	2.20 m (7'3")	2.50 m (8'2")
H110 S	✓	✓	✓	✓	✓	✓	✓	✓
H115 S	✓				✓			

CW30 – Tilt-Rotator TRS14 – CW30 (continued)

Undercarriage	Front Outriggers; Rear Blade							
Counterweight	3.7 mt				4.2 mt			
Boom Type	1 PC		VA		1 PC		VA	
Stick Length	2.20 m (7'3")	2.50 m (8'2")	2.20 m (7'3")	2.50 m (8'2")	2.20 m (7'3")	2.50 m (8'2")	2.20 m (7'3")	2.50 m (8'2")
H110 S	✓	✓	✓	✓	✓	✓	✓	✓
H115 S	✓				✓			

(continued on next page)

Matching – Wheeled Excavators *(continued)*

Match
 Working Range Front Only
 Allowed Usage on Machine Less Than 50%
 No Match

M319 *(continued)*

CW30 – Tilt-Rotator TRS14 – CW30 *(continued)*

Undercarriage	Rear Blade		
Counterweight	4.2 mt		
Boom Type	1 PC		VA
Stick Length	2.20 m (7'3")	2.50 m (8'2")	2.20 m (7'3")
H110 S	✓	✓	✓
H115 S			

CW30 – Tilt-Rotator TRS14 – CW30 *(continued)*

Undercarriage	Rear Blade (Wide U/C)						
Counterweight	3.7 mt			4.2 mt			
Boom Type	1 PC		VA	1 PC		VA	
Stick Length	2.20 m (7'3")	2.50 m (8'2")	2.20 m (7'3")	2.20 m (7'3")	2.50 m (8'2")	2.20 m (7'3")	2.50 m (8'2")
H110 S	✓	✓	✓	✓	✓	✓	✓
H115 S	✓			✓			

Tilt-Rotator TRS14 with S60 Dedicated Coupler

Undercarriage	Front and Rear Outriggers	Front Blade; Rear Outriggers	Front Outriggers; Rear Blade (Wide U/C)	Front Outriggers; Rear Blade	Rear Blade	Rear Blade (Wide U/C)
Counterweight	5.0 mt	5.0 mt	5.0 mt	5.0 mt	5.0 mt	5.0 mt
Boom Type	VA	VA	VA	VA	VA	VA
Stick Length	2.50 m (8'2")	2.50 m (8'2")	2.50 m (8'2")	2.50 m (8'2")	2.50 m (8'2")	2.50 m (8'2")
H110 S	✓	✓	✓	✓	✓	✓

Tilt-Rotator TRS14 with HCS60 Dedicated Coupler

Undercarriage	Front and Rear Outriggers		Front Blade; Rear Outriggers		Front Outriggers; Rear Blade (Wide U/C)	
Counterweight	5.0 mt		5.0 mt		5.0 mt	
Boom Type	VA		VA		VA	
Stick Length	2.50 m (8'2")	2.90 m (9'6")	2.50 m (8'2")	2.90 m (9'6")	2.50 m (8'2")	2.90 m (9'6")
H110 S	✓	✓	✓	✓	✓	✓

Tilt-Rotator TRS14 with HCS60 Dedicated Coupler *(continued)*

Undercarriage	Front Outriggers; Rear Blade		Rear Blade		Rear Blade (Wide U/C)	
Counterweight	5.0 mt		5.0 mt		5.0 mt	
Boom Type	VA		VA		VA	
Stick Length	2.50 m (8'2")	2.90 m (9'6")	2.50 m (8'2")	2.90 m (9'6")	2.50 m (8'2")	2.90 m (9'6")
H110 S	✓	✓	✓	✓	✓	✓

Tilt-Rotator TRS14 with HCS65 Dedicated Coupler

Undercarriage	Front and Rear Outriggers					
Counterweight	3.7 mt					
Boom Type	1 PC			VA		
Stick Length	2.20 m (7'3")	2.50 m (8'2")	2.90 m (9'6")	2.20 m (7'3")	2.50 m (8'2")	2.90 m (9'6")
H110 S	✓	✓	✓	✓	✓	✓
H115 S	✓	✓	✓	✓	✓	✓

(continued on next page)

Hammer Technical Specifications

Matching – Wheeled Excavators *(continued)*

Match
 * Working Range Front Only
 † Allowed Usage on Machine Less Than 50%
 No Match

M319 *(continued)*

Tilt-Rotator TRS14 with HCS65 Dedicated Coupler *(continued)*

Undercarriage	Front and Rear Outriggers					
Counterweight	4.2 mt					
Boom Type	1 PC			VA		
Stick Length	2.20 m (7'3")	2.50 m (8'2")	2.90 m (9'6")	2.20 m (7'3")	2.50 m (8'2")	2.90 m (9'6")
H110 S	✓	✓	✓	✓	✓	✓
H115 S	✓	✓	✓	✓	✓	✓

Tilt-Rotator TRS14 with HCS65 Dedicated Coupler *(continued)*

Undercarriage	Front Blade; Rear Outriggers					
Counterweight	3.7 mt					
Boom Type	1 PC			VA		
Stick Length	2.20 m (7'3")	2.50 m (8'2")	2.90 m (9'6")	2.20 m (7'3")	2.50 m (8'2")	2.90 m (9'6")
H110 S	✓	✓	✓	✓	✓	✓
H115 S	✓	✓	✓	✓	✓	✓

Tilt-Rotator TRS14 with HCS65 Dedicated Coupler *(continued)*

Undercarriage	Front Blade; Rear Outriggers					
Counterweight	4.2 mt					
Boom Type	1 PC			VA		
Stick Length	2.20 m (7'3")	2.50 m (8'2")	2.90 m (9'6")	2.20 m (7'3")	2.50 m (8'2")	2.90 m (9'6")
H110 S	✓	✓	✓	✓	✓	✓
H115 S	✓	✓	✓	✓	✓	✓

Tilt-Rotator TRS14 with HCS65 Dedicated Coupler *(continued)*

Undercarriage	Front Outriggers; Rear Blade (Wide U/C)					
Counterweight	3.7 mt					
Boom Type	1 PC			VA		
Stick Length	2.20 m (7'3")	2.50 m (8'2")	2.90 m (9'6")	2.20 m (7'3")	2.50 m (8'2")	2.90 m (9'6")
H110 S	✓	✓	✓	✓	✓	✓
H115 S	✓	✓	✓	✓	✓	✓

Tilt-Rotator TRS14 with HCS65 Dedicated Coupler *(continued)*

Undercarriage	Front Outriggers; Rear Blade (Wide U/C)					
Counterweight	4.2 mt					
Boom Type	1 PC			VA		
Stick Length	2.20 m (7'3")	2.50 m (8'2")	2.90 m (9'6")	2.20 m (7'3")	2.50 m (8'2")	2.90 m (9'6")
H110 S	✓	✓	✓	✓	✓	✓
H115 S	✓	✓	✓	✓	✓	✓

Tilt-Rotator TRS14 with HCS65 Dedicated Coupler *(continued)*

Undercarriage	Front Outriggers; Rear Blade					
Counterweight	3.7 mt					
Boom Type	1 PC			VA		
Stick Length	2.20 m (7'3")	2.50 m (8'2")	2.90 m (9'6")	2.20 m (7'3")	2.50 m (8'2")	2.90 m (9'6")
H110 S	✓	✓	✓	✓	✓	✓
H115 S	✓	✓	✓	✓	✓	✓

(continued on next page)

Matching – Wheeled Excavators *(continued)*

Match
 Working Range Front Only
 Allowed Usage on Machine Less Than 50%
 No Match

M319 *(continued)*

Tilt-Rotator TRS14 with HCS65 Dedicated Coupler *(continued)*

Undercarriage	Front Outriggers; Rear Blade					
Counterweight	4.2 mt					
Boom Type	1 PC			VA		
Stick Length	2.20 m (7'3")	2.50 m (8'2")	2.90 m (9'6")	2.20 m (7'3")	2.50 m (8'2")	2.90 m (9'6")
H110 S	✓	✓	✓	✓	✓	✓
H115 S	✓	✓	✓	✓	✓	✓

Tilt-Rotator TRS14 with HCS65 Dedicated Coupler *(continued)*

Undercarriage	Rear Blade				
Counterweight	3.7 mt				
Boom Type	1 PC			VA	
Stick Length	2.20 m (7'3")	2.50 m (8'2")	2.90 m (9'6")	2.20 m (7'3")	2.50 m (8'2")
H110 S	✓	✓	✓	✓	✓
H115 S	✓	✓		✓	

Tilt-Rotator TRS14 with HCS65 Dedicated Coupler *(continued)*

Undercarriage	Rear Blade					
Counterweight	4.2 mt					
Boom Type	1 PC			VA		
Stick Length	2.20 m (7'3")	2.50 m (8'2")	2.90 m (9'6")	2.20 m (7'3")	2.50 m (8'2")	2.90 m (9'6")
H110 S	✓	✓	✓	✓	✓	✓
H115 S	✓	✓	✓	✓	✓	✓

Tilt-Rotator TRS14 with HCS65 Dedicated Coupler *(continued)*

Undercarriage	Rear Blade (Wide U/C)					
Counterweight	3.7 mt					
Boom Type	1 PC			VA		
Stick Length	2.20 m (7'3")	2.50 m (8'2")	2.90 m (9'6")	2.20 m (7'3")	2.50 m (8'2")	2.90 m (9'6")
H110 S	✓	✓	✓	✓	✓	✓
H115 S	✓	✓	✓	✓	✓	✓

Tilt-Rotator TRS14 with HCS65 Dedicated Coupler *(continued)*

Undercarriage	Rear Blade (Wide U/C)					
Counterweight	4.2 mt					
Boom Type	1 PC			VA		
Stick Length	2.20 m (7'3")	2.50 m (8'2")	2.90 m (9'6")	2.20 m (7'3")	2.50 m (8'2")	2.90 m (9'6")
H110 S	✓	✓	✓	✓	✓	✓
H115 S	✓	✓	✓	✓	✓	✓

M320D2

Pin-on

Undercarriage	Front and Rear Outriggers				Front Outriggers; Rear Blade			
Counterweight	4.0 mt				4.0 mt			
Boom Type	1 PC		VA		1 PC		VA	
Stick Length	2.50 m (8'2")	2.80 m (9'2")	2.50 m (8'2")	2.80 m (9'2")	2.50 m (8'2")	2.80 m (9'2")	2.50 m (8'2")	2.80 m (9'2")
H115 S	✓	✓	✓	✓	✓	✓	✓	✓
H120 S	✓	✓	✓	✓	✓	✓	✓	✓
H130 S	✓	✓	✓	✓	✓	✓	✓	✓

(continued on next page)

Hammer Technical Specifications

Matching – Wheeled Excavators (continued)

Match
 Working Range Front Only
 Allowed Usage on Machine Less Than 50%
 No Match

M320D2 (continued)

Pin-on (continued)

Undercarriage	Rear Blade			
Counterweight	4.0 mt			
Boom Type	1 PC		VA	
Stick Length	2.50 m (8'2")	2.80 m (9'2")	2.50 m (8'2")	2.80 m (9'2")
H115 S	✓	✓	✓	✓
H120 S	✓	✓	✓	✓
H130 S	✓	✓*	✓	✓*

Cat Pin Grabber Coupler

Undercarriage	Front and Rear Outriggers				Front Outriggers; Rear Blade			
Counterweight	4.0 mt				4.0 mt			
Boom Type	1 PC		VA		1 PC		VA	
Stick Length	2.50 m (8'2")	2.80 m (9'2")	2.50 m (8'2")	2.80 m (9'2")	2.50 m (8'2")	2.80 m (9'2")	2.50 m (8'2")	2.80 m (9'2")
H115 S	✓	✓	✓	✓	✓	✓	✓	✓
H120 S	✓	✓	✓	✓	✓	✓	✓	✓
H130 S	✓		✓		✓		✓	

Cat Pin Grabber Coupler (continued)

Undercarriage	Rear Blade			
Counterweight	4.0 mt			
Boom Type	1 PC		VA	
Stick Length	2.50 m (8'2")	2.80 m (9'2")	2.50 m (8'2")	2.80 m (9'2")
H115 S	✓	✓	✓	✓
H120 S	✓*		✓*	
H130 S				

CW-30 S Dedicated Coupler

Undercarriage	Front and Rear Outriggers				Front Outriggers; Rear Blade			
Counterweight	4.0 mt				4.0 mt			
Boom Type	1 PC		VA		1 PC		VA	
Stick Length	2.50 m (8'2")	2.80 m (9'2")	2.50 m (8'2")	2.80 m (9'2")	2.50 m (8'2")	2.80 m (9'2")	2.50 m (8'2")	2.80 m (9'2")
H115 S	✓	✓	✓	✓	✓	✓	✓	✓
H120 S	✓	✓	✓	✓	✓	✓	✓	✓

CW-30 S Dedicated Coupler (continued)

Undercarriage	Rear Blade			
Counterweight	4.0 mt			
Boom Type	1 PC		VA	
Stick Length	2.50 m (8'2")	2.80 m (9'2")	2.50 m (8'2")	2.80 m (9'2")
H115 S	✓	✓	✓	✓
H120 S	✓	✓*	✓	✓*

(continued on next page)

Matching – Wheeled Excavators (continued)

Match
 * Working Range Front Only
 † Allowed Usage on Machine Less Than 50%
 No Match

M320D2 (continued)

CW-30 Dedicated Coupler

Undercarriage	Front and Rear Outriggers				Front Outriggers; Rear Blade			
Counterweight	4.0 mt				4.0 mt			
Boom Type	1 PC		VA		1 PC		VA	
Stick Length	2.50 m (8'2")	2.80 m (9'2")	2.50 m (8'2")	2.80 m (9'2")	2.50 m (8'2")	2.80 m (9'2")	2.50 m (8'2")	2.80 m (9'2")
H115 S	✓	✓	✓	✓	✓	✓	✓	✓
H120 S	✓	✓	✓	✓	✓	✓	✓	✓
H130 S	✓				✓			

CW-30 Dedicated Coupler (continued)

Undercarriage	Rear Blade			
Counterweight	4.0 mt			
Boom Type	1 PC		VA	
Stick Length	2.50 m (8'2")	2.80 m (9'2")	2.50 m (8'2")	2.80 m (9'2")
H115 S	✓	✓	✓	✓
H120 S	✓	✓*	✓	✓*
H130 S				

M320F

Pin-on

Undercarriage	Front and Rear Outriggers							
Counterweight	3.7 mt				4.2 mt			
Boom Type	1 PC		VA		1 PC		VA	
Stick Length	2.50 m (8'2")	2.80 m (9'2")	2.50 m (8'2")	2.80 m (9'2")	2.50 m (8'2")	2.80 m (9'2")	2.50 m (8'2")	2.80 m (9'2")
H115 S	✓	✓	✓	✓	✓	✓	✓	✓
H120 S	✓	✓	✓	✓	✓	✓	✓	✓
H130 S	✓	✓	✓	✓	✓	✓	✓	✓

Pin-on (continued)

Undercarriage	Front Outriggers; Rear Blade (Wide U/C)							
Counterweight	3.7 mt				4.2 mt			
Boom Type	1 PC		VA		1 PC		VA	
Stick Length	2.50 m (8'2")	2.80 m (9'2")	2.50 m (8'2")	2.80 m (9'2")	2.50 m (8'2")	2.80 m (9'2")	2.50 m (8'2")	2.80 m (9'2")
H115 S	✓	✓	✓	✓	✓	✓	✓	✓
H120 S	✓	✓	✓	✓	✓	✓	✓	✓
H130 S	✓	✓	✓	✓	✓	✓	✓	✓

Pin-on (continued)

Undercarriage	Front Outriggers; Rear Blade							
Counterweight	3.7 mt				4.2 mt			
Boom Type	1 PC		VA		1 PC		VA	
Stick Length	2.50 m (8'2")	2.80 m (9'2")	2.50 m (8'2")	2.80 m (9'2")	2.50 m (8'2")	2.80 m (9'2")	2.50 m (8'2")	2.80 m (9'2")
H115 S	✓	✓	✓	✓	✓	✓	✓	✓
H120 S	✓	✓	✓	✓	✓	✓	✓	✓
H130 S	✓	✓	✓	✓	✓	✓	✓	✓

(continued on next page)

Hammer Technical Specifications

Matching – Wheeled Excavators (continued)

Match
 Working Range Front Only
 † Allowed Usage on Machine Less Than 50%
 No Match

M320F (continued)

Pin-on (continued)

Undercarriage	Rear Blade							
Counterweight	3.7 mt				4.2 mt			
Boom Type	1 PC		VA		1 PC		VA	
Stick Length	2.50 m (8'2")	2.80 m (9'2")	2.50 m (8'2")	2.80 m (9'2")	2.50 m (8'2")	2.80 m (9'2")	2.50 m (8'2")	2.80 m (9'2")
H115 S	✓	✓	✓	✓	✓	✓	✓	✓
H120 S	✓	✓	✓	✓	✓	✓	✓	✓
H130 S	✓*		✓*		✓	✓	✓	✓*

Pin-on (continued)

Undercarriage	Rear Blade (Wide U/C)							
Counterweight	3.7 mt				4.2 mt			
Boom Type	1 PC		VA		1 PC		VA	
Stick Length	2.50 m (8'2")	2.80 m (9'2")	2.50 m (8'2")	2.80 m (9'2")	2.50 m (8'2")	2.80 m (9'2")	2.50 m (8'2")	2.80 m (9'2")
H115 S	✓	✓	✓	✓	✓	✓	✓	✓
H120 S	✓	✓	✓	✓	✓	✓	✓	✓
H130 S	✓	✓	✓	✓*	✓	✓	✓	✓

Cat Pin Grabber Coupler

Undercarriage	Front and Rear Outriggers							
Counterweight	3.7 mt				4.2 mt			
Boom Type	1 PC		VA		1 PC		VA	
Stick Length	2.50 m (8'2")	2.80 m (9'2")	2.50 m (8'2")	2.80 m (9'2")	2.50 m (8'2")	2.80 m (9'2")	2.50 m (8'2")	2.80 m (9'2")
H115 S	✓	✓	✓	✓	✓	✓	✓	✓
H120 S	✓	✓	✓	✓	✓	✓	✓	✓
H130 S	✓	✓	✓		✓	✓	✓	

Cat Pin Grabber Coupler (continued)

Undercarriage	Front Outriggers; Rear Blade (Wide U/C)							
Counterweight	3.7 mt				4.2 mt			
Boom Type	1 PC		VA		1 PC		VA	
Stick Length	2.50 m (8'2")	2.80 m (9'2")	2.50 m (8'2")	2.80 m (9'2")	2.50 m (8'2")	2.80 m (9'2")	2.50 m (8'2")	2.80 m (9'2")
H115 S	✓	✓	✓	✓	✓	✓	✓	✓
H120 S	✓	✓	✓	✓	✓	✓	✓	✓
H130 S	✓		✓		✓		✓	

Cat Pin Grabber Coupler (continued)

Undercarriage	Front Outriggers; Rear Blade							
Counterweight	3.7 mt				4.2 mt			
Boom Type	1 PC		VA		1 PC		VA	
Stick Length	2.50 m (8'2")	2.80 m (9'2")	2.50 m (8'2")	2.80 m (9'2")	2.50 m (8'2")	2.80 m (9'2")	2.50 m (8'2")	2.80 m (9'2")
H115 S	✓	✓	✓	✓	✓	✓	✓	✓
H120 S	✓	✓	✓	✓	✓	✓	✓	✓
H130 S	✓	✓	✓		✓	✓	✓	

(continued on next page)

Hammer Technical Specifications

Matching – Wheeled Excavators (continued)

Match
 * Working Range Front Only
 † Allowed Usage on Machine Less Than 50%
 No Match

M320F (continued)

Cat Pin Grabber Coupler (continued)

Undercarriage	Rear Blade							
	3.7 mt				4.2 mt			
	1 PC		VA		1 PC		VA	
Stick Length	2.50 m (8'2")	2.80 m (9'2")	2.50 m (8'2")	2.80 m (9'2")	2.50 m (8'2")	2.80 m (9'2")	2.50 m (8'2")	2.80 m (9'2")
H115 S	✓	✓	✓	✓	✓	✓	✓	✓
H120 S					✓	✓*	✓*	
H130 S								

Cat Pin Grabber Coupler (continued)

Undercarriage	Rear Blade (Wide U/C)							
	3.7 mt				4.2 mt			
	1 PC		VA		1 PC		VA	
Stick Length	2.50 m (8'2")	2.80 m (9'2")	2.50 m (8'2")	2.80 m (9'2")	2.50 m (8'2")	2.80 m (9'2")	2.50 m (8'2")	2.80 m (9'2")
H115 S	✓	✓	✓	✓	✓	✓	✓	✓
H120 S	✓	✓*	✓	✓*	✓	✓	✓	✓
H130 S					✓*		✓*	

CW-30 S Dedicated Coupler

Undercarriage	Front and Rear Outriggers							
	3.7 mt				4.2 mt			
	1 PC		VA		1 PC		VA	
Stick Length	2.50 m (8'2")	2.80 m (9'2")	2.50 m (8'2")	2.80 m (9'2")	2.50 m (8'2")	2.80 m (9'2")	2.50 m (8'2")	2.80 m (9'2")
H115 S	✓	✓	✓	✓	✓	✓	✓	✓
H120 S	✓	✓	✓	✓	✓	✓	✓	✓
H130 S	✓	✓	✓	✓	✓	✓	✓	✓

CW-30 S Dedicated Coupler (continued)

Undercarriage	Front Outriggers; Rear Blade (Wide U/C)							
	3.7 mt				4.2 mt			
	1 PC		VA		1 PC		VA	
Stick Length	2.50 m (8'2")	2.80 m (9'2")	2.50 m (8'2")	2.80 m (9'2")	2.50 m (8'2")	2.80 m (9'2")	2.50 m (8'2")	2.80 m (9'2")
H115 S	✓	✓	✓	✓	✓	✓	✓	✓
H120 S	✓	✓	✓	✓	✓	✓	✓	✓
H130 S	✓	✓	✓	✓	✓	✓	✓	✓

CW-30 S Dedicated Coupler (continued)

Undercarriage	Front Outriggers; Rear Blade							
	3.7 mt				4.2 mt			
	1 PC		VA		1 PC		VA	
Stick Length	2.50 m (8'2")	2.80 m (9'2")	2.50 m (8'2")	2.80 m (9'2")	2.50 m (8'2")	2.80 m (9'2")	2.50 m (8'2")	2.80 m (9'2")
H115 S	✓	✓	✓	✓	✓	✓	✓	✓
H120 S	✓	✓	✓	✓	✓	✓	✓	✓
H130 S	✓	✓	✓	✓	✓	✓	✓	✓

(continued on next page)

Hammer Technical Specifications

Matching – Wheeled Excavators (continued)

Match
 * Working Range Front Only
 † Allowed Usage on Machine Less Than 50%
 No Match

M320F (continued)

CW-30 S Dedicated Coupler (continued)

Undercarriage	Rear Blade							
Counterweight	3.7 mt				4.2 mt			
Boom Type	1 PC		VA		1 PC		VA	
Stick Length	2.50 m (8'2")	2.80 m (9'2")	2.50 m (8'2")	2.80 m (9'2")	2.50 m (8'2")	2.80 m (9'2")	2.50 m (8'2")	2.80 m (9'2")
H115 S	✓	✓	✓	✓	✓	✓	✓	✓
H120 S	✓*	✓*	✓*		✓	✓	✓	✓
H130 S								

CW-30 S Dedicated Coupler (continued)

Undercarriage	Rear Blade (Wide U/C)							
Counterweight	3.7 mt				4.2 mt			
Boom Type	1 PC		VA		1 PC		VA	
Stick Length	2.50 m (8'2")	2.80 m (9'2")	2.50 m (8'2")	2.80 m (9'2")	2.50 m (8'2")	2.80 m (9'2")	2.50 m (8'2")	2.80 m (9'2")
H115 S	✓	✓	✓	✓	✓	✓	✓	✓
H120 S	✓	✓	✓	✓	✓	✓	✓	✓
H130 S	✓*				✓	✓*	✓	

CW-30 Dedicated Coupler

Undercarriage	Front and Rear Outriggers							
Counterweight	3.7 mt				4.2 mt			
Boom Type	1 PC		VA		1 PC		VA	
Stick Length	2.50 m (8'2")	2.80 m (9'2")	2.50 m (8'2")	2.80 m (9'2")	2.50 m (8'2")	2.80 m (9'2")	2.50 m (8'2")	2.80 m (9'2")
H115 S	✓	✓	✓	✓	✓	✓	✓	✓
H120 S	✓	✓	✓	✓	✓	✓	✓	✓
H130 S	✓	✓	✓	✓	✓	✓	✓	✓

CW-30 Dedicated Coupler (continued)

Undercarriage	Front Outriggers; Rear Blade (Wide U/C)							
Counterweight	3.7 mt				4.2 mt			
Boom Type	1 PC		VA		1 PC		VA	
Stick Length	2.50 m (8'2")	2.80 m (9'2")	2.50 m (8'2")	2.80 m (9'2")	2.50 m (8'2")	2.80 m (9'2")	2.50 m (8'2")	2.80 m (9'2")
H115 S	✓	✓	✓	✓	✓	✓	✓	✓
H120 S	✓	✓	✓	✓	✓	✓	✓	✓
H130 S	✓	✓	✓	✓	✓	✓	✓	

CW-30 Dedicated Coupler (continued)

Undercarriage	Front Outriggers; Rear Blade							
Counterweight	3.7 mt				4.2 mt			
Boom Type	1 PC		VA		1 PC		VA	
Stick Length	2.50 m (8'2")	2.80 m (9'2")	2.50 m (8'2")	2.80 m (9'2")	2.50 m (8'2")	2.80 m (9'2")	2.50 m (8'2")	2.80 m (9'2")
H115 S	✓	✓	✓	✓	✓	✓	✓	✓
H120 S	✓	✓	✓	✓	✓	✓	✓	✓
H130 S	✓	✓	✓	✓	✓	✓	✓	✓

(continued on next page)

Matching – Wheeled Excavators (continued)

Match
 Working Range Front Only
 Allowed Usage on Machine Less Than 50%
 No Match

M320F (continued)

CW-30 Dedicated Coupler (continued)

Undercarriage	Rear Blade							
	3.7 mt				4.2 mt			
	1 PC		VA		1 PC		VA	
Stick Length	2.50 m (8'2")	2.80 m (9'2")	2.50 m (8'2")	2.80 m (9'2")	2.50 m (8'2")	2.80 m (9'2")	2.50 m (8'2")	2.80 m (9'2")
H115 S	✓	✓	✓	✓	✓	✓	✓	✓
H120 S	✓*	✓*	✓*		✓	✓	✓	✓*
H130 S								

CW-30 Dedicated Coupler (continued)

Undercarriage	Rear Blade (Wide U/C)							
	3.7 mt				4.2 mt			
	1 PC		VA		1 PC		VA	
Stick Length	2.50 m (8'2")	2.80 m (9'2")	2.50 m (8'2")	2.80 m (9'2")	2.50 m (8'2")	2.80 m (9'2")	2.50 m (8'2")	2.80 m (9'2")
H115 S	✓	✓	✓	✓	✓	✓	✓	✓
H120 S	✓	✓	✓	✓	✓	✓	✓	✓
H130 S	✓*				✓	✓*	✓	

M320

Pin-on

Undercarriage	Front and Rear Outriggers			
	3.6 mt			
	1 PC		VA	
Stick Length	2.50 m (8'2")	2.90 m (9'6")	2.50 m (8'2")	2.90 m (9'6")
H115 S	✓	✓	✓	✓
H120 S	✓	✓	✓	✓
H130 S	✓	✓	✓	✓

Pin-on (continued)

Undercarriage	Front and Rear Outriggers					
	4.2 mt				4.8 mt	
	1 PC		VA		1 PC	
Stick Length	2.50 m (8'2")	2.90 m (9'6")	2.50 m (8'2")	2.90 m (9'6")	2.50 m (8'2")	2.90 m (9'6")
H115 S	✓	✓	✓	✓	✓	✓
H120 S	✓	✓	✓	✓	✓	✓
H130 S	✓	✓	✓	✓	✓	✓

Pin-on (continued)

Undercarriage	Front Blade; Rear Outriggers			
	3.6 mt			
	1 PC		VA	
Stick Length	2.50 m (8'2")	2.90 m (9'6")	2.50 m (8'2")	2.90 m (9'6")
H115 S	✓	✓	✓	✓
H120 S	✓	✓	✓	✓
H130 S	✓	✓	✓	✓

(continued on next page)

Hammer Technical Specifications

Matching – Wheeled Excavators (continued)

Match
 Working Range Front Only
 † Allowed Usage on Machine Less Than 50%
 No Match

M320 (continued)

Pin-on (continued)

Undercarriage	Front Blade; Rear Outriggers					
Counterweight	4.2 mt				4.8 mt	
Boom Type	1 PC		VA		1 PC	
Stick Length	2.50 m (8'2")	2.90 m (9'6")	2.50 m (8'2")	2.90 m (9'6")	2.50 m (8'2")	2.90 m (9'6")
H115 S	✓	✓	✓	✓	✓	✓
H120 S	✓	✓	✓	✓	✓	✓
H130 S	✓	✓	✓	✓	✓	✓

Pin-on (continued)

Undercarriage	Front Outriggers; Rear Blade (Wide U/C)			
Counterweight	3.6 mt			
Boom Type	1 PC		VA	
Stick Length	2.50 m (8'2")	2.90 m (9'6")	2.50 m (8'2")	2.90 m (9'6")
H115 S	✓	✓	✓	✓
H120 S	✓	✓	✓	✓
H130 S	✓	✓	✓	✓

Pin-on (continued)

Undercarriage	Front Outriggers; Rear Blade (Wide U/C)					
Counterweight	4.2 mt				4.8 mt	
Boom Type	1 PC		VA		1 PC	
Stick Length	2.50 m (8'2")	2.90 m (9'6")	2.50 m (8'2")	2.90 m (9'6")	2.50 m (8'2")	2.90 m (9'6")
H115 S	✓	✓	✓	✓	✓	✓
H120 S	✓	✓	✓	✓	✓	✓
H130 S	✓	✓	✓	✓	✓	✓

Pin-on (continued)

Undercarriage	Front Outriggers; Rear Blade			
Counterweight	3.6 mt			
Boom Type	1 PC		VA	
Stick Length	2.50 m (8'2")	2.90 m (9'6")	2.50 m (8'2")	2.90 m (9'6")
H115 S	✓	✓	✓	✓
H120 S	✓	✓	✓	✓
H130 S	✓	✓	✓	✓

Pin-on (continued)

Undercarriage	Front Outriggers; Rear Blade					
Counterweight	4.2 mt				4.8 mt	
Boom Type	1 PC		VA		1 PC	
Stick Length	2.50 m (8'2")	2.90 m (9'6")	2.50 m (8'2")	2.90 m (9'6")	2.50 m (8'2")	2.90 m (9'6")
H115 S	✓	✓	✓	✓	✓	✓
H120 S	✓	✓	✓	✓	✓	✓
H130 S	✓	✓	✓	✓	✓	✓

(continued on next page)

Matching – Wheeled Excavators (continued)

Match
 Working Range Front Only
 Allowed Usage on Machine Less Than 50%
 No Match

M320 (continued)

Pin-on (continued)

Undercarriage	Rear Blade			
Counterweight	3.6 mt			
Boom Type	1 PC		VA	
Stick Length	2.50 m (8'2")	2.90 m (9'6")	2.50 m (8'2")	2.90 m (9'6")
H115 S	✓	✓	✓	✓
H120 S	✓	✓*	✓	✓
H130 S			✓*	

Pin-on (continued)

Undercarriage	Rear Blade					
Counterweight	4.2 mt				4.8 mt	
Boom Type	1 PC		VA		1 PC	
Stick Length	2.50 m (8'2")	2.90 m (9'6")	2.50 m (8'2")	2.90 m (9'6")	2.50 m (8'2")	2.90 m (9'6")
H115 S	✓	✓	✓	✓	✓	✓
H120 S	✓	✓	✓	✓	✓	
H130 S	✓*		✓	✓*	✓	

Pin-on (continued)

Undercarriage	Rear Blade (Wide U/C)			
Counterweight	3.6 mt			
Boom Type	1 PC		VA	
Stick Length	2.50 m (8'2")	2.90 m (9'6")	2.50 m (8'2")	2.90 m (9'6")
H115 S	✓	✓	✓	✓
H120 S	✓	✓	✓	✓
H130 S	✓*		✓	✓*

Pin-on (continued)

Undercarriage	Rear Blade (Wide U/C)					
Counterweight	4.2 mt				4.8 mt	
Boom Type	1 PC		VA		1 PC	
Stick Length	2.50 m (8'2")	2.90 m (9'6")	2.50 m (8'2")	2.90 m (9'6")	2.50 m (8'2")	2.90 m (9'6")
H115 S	✓	✓	✓	✓	✓	✓
H120 S	✓	✓	✓	✓	✓	✓
H130 S	✓	✓	✓	✓	✓	✓

Cat Pin Grabber Coupler

Undercarriage	Front and Rear Outriggers			
Counterweight	3.6 mt			
Boom Type	1 PC		VA	
Stick Length	2.50 m (8'2")	2.90 m (9'6")	2.50 m (8'2")	2.90 m (9'6")
H115 S	✓	✓	✓	✓
H120 S	✓	✓	✓	✓
H130 S	✓	✓	✓	

(continued on next page)

Hammer Technical Specifications

Matching – Wheeled Excavators (continued)

Match
 Working Range Front Only
 Allowed Usage on Machine Less Than 50%
 No Match

M320 (continued)

Cat Pin Grabber Coupler (continued)

Undercarriage	Front and Rear Outriggers					
Counterweight	4.2 mt				4.8 mt	
Boom Type	1 PC		VA		1 PC	
Stick Length	2.50 m (8'2")	2.90 m (9'6")	2.50 m (8'2")	2.90 m (9'6")	2.50 m (8'2")	2.90 m (9'6")
H115 S	✓	✓	✓	✓	✓	✓
H120 S	✓	✓	✓	✓	✓	✓
H130 S	✓	✓	✓		✓	✓

Cat Pin Grabber Coupler (continued)

Undercarriage	Front Blade; Rear Outriggers			
Counterweight	3.6 mt			
Boom Type	1 PC		VA	
Stick Length	2.50 m (8'2")	2.90 m (9'6")	2.50 m (8'2")	2.90 m (9'6")
H115 S	✓	✓	✓	✓
H120 S	✓	✓	✓	✓
H130 S	✓	✓	✓	

Cat Pin Grabber Coupler (continued)

Undercarriage	Front Blade; Rear Outriggers					
Counterweight	4.2 mt				4.8 mt	
Boom Type	1 PC		VA		1 PC	
Stick Length	2.50 m (8'2")	2.90 m (9'6")	2.50 m (8'2")	2.90 m (9'6")	2.50 m (8'2")	2.90 m (9'6")
H115 S	✓	✓	✓	✓	✓	✓
H120 S	✓	✓	✓	✓	✓	✓
H130 S	✓	✓	✓		✓	✓

Cat Pin Grabber Coupler (continued)

Undercarriage	Front Outriggers; Rear Blade (Wide U/C)			
Counterweight	3.6 mt			
Boom Type	1 PC		VA	
Stick Length	2.50 m (8'2")	2.90 m (9'6")	2.50 m (8'2")	2.90 m (9'6")
H115 S	✓	✓	✓	✓
H120 S	✓	✓	✓	✓
H130 S	✓	✓	✓	

Cat Pin Grabber Coupler (continued)

Undercarriage	Front Outriggers; Rear Blade (Wide U/C)					
Counterweight	4.2 mt				4.8 mt	
Boom Type	1 PC		VA		1 PC	
Stick Length	2.50 m (8'2")	2.90 m (9'6")	2.50 m (8'2")	2.90 m (9'6")	2.50 m (8'2")	2.90 m (9'6")
H115 S	✓	✓	✓	✓	✓	✓
H120 S	✓	✓	✓	✓	✓	✓
H130 S	✓	✓	✓		✓	✓

(continued on next page)

Matching – Wheeled Excavators (continued)

Match
 Working Range Front Only
 Allowed Usage on Machine Less Than 50%
 No Match

M320 (continued)

Cat Pin Grabber Coupler (continued)

Undercarriage	Front Outriggers; Rear Blade			
Counterweight	3.6 mt			
Boom Type	1 PC		VA	
Stick Length	2.50 m (8'2")	2.90 m (9'6")	2.50 m (8'2")	2.90 m (9'6")
H115 S	✓	✓	✓	✓
H120 S	✓	✓	✓	✓
H130 S	✓	✓	✓	

Cat Pin Grabber Coupler (continued)

Undercarriage	Front Outriggers; Rear Blade					
Counterweight	4.2 mt				4.8 mt	
Boom Type	1 PC		VA		1 PC	
Stick Length	2.50 m (8'2")	2.90 m (9'6")	2.50 m (8'2")	2.90 m (9'6")	2.50 m (8'2")	2.90 m (9'6")
H115 S	✓	✓	✓	✓	✓	✓
H120 S	✓	✓	✓	✓	✓	✓
H130 S	✓	✓	✓		✓	✓

Cat Pin Grabber Coupler (continued)

Undercarriage	Rear Blade			
Counterweight	3.6 mt			
Boom Type	1 PC		VA	
Stick Length	2.50 m (8'2")	2.90 m (9'6")	2.50 m (8'2")	2.90 m (9'6")
H115 S	✓	✓*	✓	✓
H120 S				
H130 S				

Cat Pin Grabber Coupler (continued)

Undercarriage	Rear Blade					
Counterweight	4.2 mt				4.8 mt	
Boom Type	1 PC		VA		1 PC	
Stick Length	2.50 m (8'2")	2.90 m (9'6")	2.50 m (8'2")	2.90 m (9'6")	2.50 m (8'2")	2.90 m (9'6")
H115 S	✓	✓	✓	✓	✓	✓
H120 S			✓		✓	✓*
H130 S						

Cat Pin Grabber Coupler (continued)

Undercarriage	Rear Blade (Wide U/C)			
Counterweight	3.6 mt			
Boom Type	1 PC		VA	
Stick Length	2.50 m (8'2")	2.90 m (9'6")	2.50 m (8'2")	2.90 m (9'6")
H115 S	✓	✓	✓	✓
H120 S			✓	
H130 S				

(continued on next page)

Hammer Technical Specifications

Matching – Wheeled Excavators (continued)

Match
 * Working Range Front Only
 † Allowed Usage on Machine Less Than 50%
 No Match

M320 (continued)

Cat Pin Grabber Coupler (continued)

Undercarriage	Rear Blade (Wide U/C)					
Counterweight	4.2 mt				4.8 mt	
Boom Type	1 PC		VA		1 PC	
Stick Length	2.50 m (8'2")	2.90 m (9'6")	2.50 m (8'2")	2.90 m (9'6")	2.50 m (8'2")	2.90 m (9'6")
H115 S	✓	✓	✓	✓	✓	✓
H120 S	✓	✓*	✓	✓	✓	✓
H130 S			✓†*		✓†*	

CW-40 S Dedicated Coupler

Undercarriage	Front and Rear Outriggers			
Counterweight	3.6 mt			
Boom Type	1 PC		VA	
Stick Length	2.50 m (8'2")	2.90 m (9'6")	2.50 m (8'2")	2.90 m (9'6")
H115 S	✓	✓	✓	✓
H120 S	✓	✓	✓	✓
H130 S	✓	✓	✓	

CW-40 S Dedicated Coupler (continued)

Undercarriage	Front and Rear Outriggers					
Counterweight	4.2 mt				4.8 mt	
Boom Type	1 PC		VA		1 PC	
Stick Length	2.50 m (8'2")	2.90 m (9'6")	2.50 m (8'2")	2.90 m (9'6")	2.50 m (8'2")	2.90 m (9'6")
H115 S	✓	✓	✓	✓	✓	✓
H120 S	✓	✓	✓	✓	✓	✓
H130 S	✓	✓	✓		✓	✓

CW-40 S Dedicated Coupler (continued)

Undercarriage	Front Blade; Rear Outriggers			
Counterweight	3.6 mt			
Boom Type	1 PC		VA	
Stick Length	2.50 m (8'2")	2.90 m (9'6")	2.50 m (8'2")	2.90 m (9'6")
H115 S	✓	✓	✓	✓
H120 S	✓	✓	✓	✓
H130 S	✓	✓	✓	

CW-40 S Dedicated Coupler (continued)

Undercarriage	Front Blade; Rear Outriggers					
Counterweight	4.2 mt				4.8 mt	
Boom Type	1 PC		VA		1 PC	
Stick Length	2.50 m (8'2")	2.90 m (9'6")	2.50 m (8'2")	2.90 m (9'6")	2.50 m (8'2")	2.90 m (9'6")
H115 S	✓	✓	✓	✓	✓	✓
H120 S	✓	✓	✓	✓	✓	✓
H130 S	✓	✓	✓		✓	✓

(continued on next page)

Matching – Wheeled Excavators *(continued)*

Match
 * Working Range Front Only
 † Allowed Usage on Machine Less Than 50%
 No Match

M320 *(continued)*

CW-40 S Dedicated Coupler *(continued)*

Undercarriage	Front Outriggers; Rear Blade (Wide U/C)			
Counterweight	3.6 mt			
Boom Type	1 PC		VA	
Stick Length	2.50 m (8'2")	2.90 m (9'6")	2.50 m (8'2")	2.90 m (9'6")
H115 S	✓	✓	✓	✓
H120 S	✓	✓	✓	✓
H130 S	✓	✓	✓	

CW-40 S Dedicated Coupler *(continued)*

Undercarriage	Front Outriggers; Rear Blade (Wide U/C)					
Counterweight	4.2 mt				4.8 mt	
Boom Type	1 PC		VA		1 PC	
Stick Length	2.50 m (8'2")	2.90 m (9'6")	2.50 m (8'2")	2.90 m (9'6")	2.50 m (8'2")	2.90 m (9'6")
H115 S	✓	✓	✓	✓	✓	✓
H120 S	✓	✓	✓	✓	✓	✓
H130 S	✓	✓	✓		✓	✓

CW-40 S Dedicated Coupler *(continued)*

Undercarriage	Front Outriggers; Rear Blade			
Counterweight	3.6 mt			
Boom Type	1 PC		VA	
Stick Length	2.50 m (8'2")	2.90 m (9'6")	2.50 m (8'2")	2.90 m (9'6")
H115 S	✓	✓	✓	✓
H120 S	✓	✓	✓	✓
H130 S	✓	✓	✓	

CW-40 S Dedicated Coupler *(continued)*

Undercarriage	Front Outriggers; Rear Blade					
Counterweight	4.2 mt				4.8 mt	
Boom Type	1 PC		VA		1 PC	
Stick Length	2.50 m (8'2")	2.90 m (9'6")	2.50 m (8'2")	2.90 m (9'6")	2.50 m (8'2")	2.90 m (9'6")
H115 S	✓	✓	✓	✓	✓	✓
H120 S	✓	✓	✓	✓	✓	✓
H130 S	✓	✓	✓		✓	✓

CW-40 S Dedicated Coupler *(continued)*

Undercarriage	Rear Blade			
Counterweight	3.6 mt			
Boom Type	1 PC		VA	
Stick Length	2.50 m (8'2")	2.90 m (9'6")	2.50 m (8'2")	2.90 m (9'6")
H115 S	✓	✓	✓	✓
H120 S			✓	
H130 S				

(continued on next page)

Hammer Technical Specifications

Matching – Wheeled Excavators (continued)

Match
 * Working Range Front Only
 † Allowed Usage on Machine Less Than 50%
 No Match

M320 (continued)

CW-40 S Dedicated Coupler (continued)

Undercarriage	Rear Blade					
Counterweight	4.2 mt				4.8 mt	
Boom Type	1 PC		VA		1 PC	
Stick Length	2.50 m (8'2")	2.90 m (9'6")	2.50 m (8'2")	2.90 m (9'6")	2.50 m (8'2")	2.90 m (9'6")
H115 S	✓	✓	✓	✓	✓	✓
H120 S	✓		✓	✓	✓	✓
H130 S					✓	

CW-40 S Dedicated Coupler (continued)

Undercarriage	Rear Blade (Wide U/C)			
Counterweight	3.6 mt			
Boom Type	1 PC		VA	
Stick Length	2.50 m (8'2")	2.90 m (9'6")	2.50 m (8'2")	2.90 m (9'6")
H115 S	✓	✓	✓	✓
H120 S	✓		✓	✓
H130 S				

CW-40 S Dedicated Coupler (continued)

Undercarriage	Rear Blade (Wide U/C)					
Counterweight	4.2 mt				4.8 mt	
Boom Type	1 PC		VA		1 PC	
Stick Length	2.50 m (8'2")	2.90 m (9'6")	2.50 m (8'2")	2.90 m (9'6")	2.50 m (8'2")	2.90 m (9'6")
H115 S	✓	✓	✓	✓	✓	✓
H120 S	✓	✓	✓	✓	✓	✓
H130 S	✓		✓		✓	✓

CW-40 Dedicated Coupler

Undercarriage	Front and Rear Outriggers			
Counterweight	3.6 mt			
Boom Type	1 PC		VA	
Stick Length	2.50 m (8'2")	2.90 m (9'6")	2.50 m (8'2")	2.90 m (9'6")
H115 S	✓	✓	✓	✓
H120 S	✓	✓	✓	✓
H130 S	✓	✓	✓	

CW-40 Dedicated Coupler (continued)

Undercarriage	Front and Rear Outriggers					
Counterweight	4.2 mt				4.8 mt	
Boom Type	1 PC		VA		1 PC	
Stick Length	2.50 m (8'2")	2.90 m (9'6")	2.50 m (8'2")	2.90 m (9'6")	2.50 m (8'2")	2.90 m (9'6")
H115 S	✓	✓	✓	✓	✓	✓
H120 S	✓	✓	✓	✓	✓	✓
H130 S	✓	✓	✓		✓	✓

(continued on next page)

Matching – Wheeled Excavators *(continued)*

Match
 * Working Range Front Only
 † Allowed Usage on Machine Less Than 50%
 No Match

M320 *(continued)*

CW-40 Dedicated Coupler *(continued)*

Undercarriage	Front Blade; Rear Outriggers			
Counterweight	3.6 mt			
Boom Type	1 PC		VA	
Stick Length	2.50 m (8'2")	2.90 m (9'6")	2.50 m (8'2")	2.90 m (9'6")
H115 S	✓	✓	✓	✓
H120 S	✓	✓	✓	✓
H130 S	✓	✓	✓	

CW-40 Dedicated Coupler *(continued)*

Undercarriage	Front Blade; Rear Outriggers					
Counterweight	4.2 mt				4.8 mt	
Boom Type	1 PC		VA		1 PC	
Stick Length	2.50 m (8'2")	2.90 m (9'6")	2.50 m (8'2")	2.90 m (9'6")	2.50 m (8'2")	2.90 m (9'6")
H115 S	✓	✓	✓	✓	✓	✓
H120 S	✓	✓	✓	✓	✓	✓
H130 S	✓	✓	✓		✓	✓

CW-40 Dedicated Coupler *(continued)*

Undercarriage	Front Outriggers; Rear Blade (Wide U/C)			
Counterweight	3.6 mt			
Boom Type	1 PC		VA	
Stick Length	2.50 m (8'2")	2.90 m (9'6")	2.50 m (8'2")	2.90 m (9'6")
H115 S	✓	✓	✓	✓
H120 S	✓	✓	✓	✓
H130 S	✓	✓	✓	

CW-40 Dedicated Coupler *(continued)*

Undercarriage	Front Outriggers; Rear Blade (Wide U/C)					
Counterweight	4.2 mt				4.8 mt	
Boom Type	1 PC		VA		1 PC	
Stick Length	2.50 m (8'2")	2.90 m (9'6")	2.50 m (8'2")	2.90 m (9'6")	2.50 m (8'2")	2.90 m (9'6")
H115 S	✓	✓	✓	✓	✓	✓
H120 S	✓	✓	✓	✓	✓	✓
H130 S	✓	✓	✓		✓	✓

CW-40 Dedicated Coupler *(continued)*

Undercarriage	Front Outriggers; Rear Blade			
Counterweight	3.6 mt			
Boom Type	1 PC		VA	
Stick Length	2.50 m (8'2")	2.90 m (9'6")	2.50 m (8'2")	2.90 m (9'6")
H115 S	✓	✓	✓	✓
H120 S	✓	✓	✓	✓
H130 S	✓	✓	✓	

(continued on next page)

Hammer Technical Specifications

Matching – Wheeled Excavators *(continued)*

Match
 * Working Range Front Only
 † Allowed Usage on Machine Less Than 50%
 No Match

M320 *(continued)*

CW-40 Dedicated Coupler *(continued)*

Undercarriage	Front Outriggers; Rear Blade					
Counterweight	4.2 mt				4.8 mt	
Boom Type	1 PC		VA		1 PC	
Stick Length	2.50 m (8'2")	2.90 m (9'6")	2.50 m (8'2")	2.90 m (9'6")	2.50 m (8'2")	2.90 m (9'6")
H115 S	✓	✓	✓	✓	✓	✓
H120 S	✓	✓	✓	✓	✓	✓
H130 S	✓	✓	✓		✓	✓

CW-40 Dedicated Coupler *(continued)*

Undercarriage	Rear Blade			
Counterweight	3.6 mt			
Boom Type	1 PC		VA	
Stick Length	2.50 m (8'2")	2.90 m (9'6")	2.50 m (8'2")	2.90 m (9'6")
H115 S	✓	✓	✓	✓
H120 S				
H130 S				

CW-40 Dedicated Coupler *(continued)*

Undercarriage	Rear Blade					
Counterweight	4.2 mt				4.8 mt	
Boom Type	1 PC		VA		1 PC	
Stick Length	2.50 m (8'2")	2.90 m (9'6")	2.50 m (8'2")	2.90 m (9'6")	2.50 m (8'2")	2.90 m (9'6")
H115 S	✓	✓	✓	✓	✓	
H120 S	✓		✓	✓	✓	✓
H130 S						

CW-40 Dedicated Coupler *(continued)*

Undercarriage	Rear Blade (Wide U/C)			
Counterweight	3.6 mt			
Boom Type	1 PC		VA	
Stick Length	2.50 m (8'2")	2.90 m (9'6")	2.50 m (8'2")	2.90 m (9'6")
H115 S	✓	✓	✓	✓
H120 S	✓		✓	✓
H130 S				

CW-40 Dedicated Coupler *(continued)*

Undercarriage	Rear Blade (Wide U/C)					
Counterweight	4.2 mt				4.8 mt	
Boom Type	1 PC		VA		1 PC	
Stick Length	2.50 m (8'2")	2.90 m (9'6")	2.50 m (8'2")	2.90 m (9'6")	2.50 m (8'2")	2.90 m (9'6")
H115 S	✓	✓	✓	✓	✓	✓
H120 S	✓	✓	✓	✓	✓	✓
H130 S			✓		✓	✓

(continued on next page)

Hammer Technical Specifications

Matching – Wheeled Excavators (continued)

Match
 * Working Range Front Only
 † Allowed Usage on Machine Less Than 50%
 No Match

M320 (continued)

S70 Dedicated Coupler

Undercarriage	Front and Rear Outriggers							
Counterweight	3.6 mt				4.2 mt			
Boom Type	1 PC		VA		1 PC		VA	
Stick Length	2.50 m (8'2")	2.90 m (9'6")	2.50 m (8'2")	2.90 m (9'6")	2.50 m (8'2")	2.90 m (9'6")	2.50 m (8'2")	2.90 m (9'6")
H115 S	✓	✓	✓	✓	✓	✓	✓	✓
H120 S	✓	✓	✓	✓	✓	✓	✓	✓
H130 S	✓	✓	✓		✓	✓	✓	

S70 Dedicated Coupler (continued)

Undercarriage	Front Blade; Rear Outriggers							
Counterweight	3.6 mt				4.2 mt			
Boom Type	1 PC		VA		1 PC		VA	
Stick Length	2.50 m (8'2")	2.90 m (9'6")	2.50 m (8'2")	2.90 m (9'6")	2.50 m (8'2")	2.90 m (9'6")	2.50 m (8'2")	2.90 m (9'6")
H115 S	✓	✓	✓	✓	✓	✓	✓	✓
H120 S	✓	✓	✓	✓	✓	✓	✓	✓
H130 S	✓	✓	✓		✓	✓	✓	

S70 Dedicated Coupler (continued)

Undercarriage	Front Outriggers; Rear Blade (Wide U/C)							
Counterweight	3.6 mt				4.2 mt			
Boom Type	1 PC		VA		1 PC		VA	
Stick Length	2.50 m (8'2")	2.90 m (9'6")	2.50 m (8'2")	2.90 m (9'6")	2.50 m (8'2")	2.90 m (9'6")	2.50 m (8'2")	2.90 m (9'6")
H115 S	✓	✓	✓	✓	✓	✓	✓	✓
H120 S	✓	✓	✓	✓	✓	✓	✓	✓
H130 S	✓	✓	✓		✓	✓	✓	

S70 Dedicated Coupler (continued)

Undercarriage	Front Outriggers; Rear Blade							
Counterweight	3.6 mt				4.2 mt			
Boom Type	1 PC		VA		1 PC		VA	
Stick Length	2.50 m (8'2")	2.90 m (9'6")	2.50 m (8'2")	2.90 m (9'6")	2.50 m (8'2")	2.90 m (9'6")	2.50 m (8'2")	2.90 m (9'6")
H115 S	✓	✓	✓	✓	✓	✓	✓	✓
H120 S	✓	✓	✓	✓	✓	✓	✓	✓
H130 S	✓	✓	✓		✓	✓	✓	

S70 Dedicated Coupler (continued)

Undercarriage	Rear Blade							
Counterweight	3.6 mt				4.2 mt			
Boom Type	1 PC		VA		1 PC		VA	
Stick Length	2.50 m (8'2")	2.90 m (9'6")	2.50 m (8'2")	2.90 m (9'6")	2.50 m (8'2")	2.90 m (9'6")	2.50 m (8'2")	2.90 m (9'6")
H115 S	✓	✓	✓	✓	✓	✓	✓	✓
H120 S					✓		✓	✓
H130 S								

(continued on next page)

Hammer Technical Specifications

Matching – Wheeled Excavators (continued)

Match
 Working Range Front Only
 † Allowed Usage on Machine Less Than 50%
 No Match

M320 (continued)

S70 Dedicated Coupler (continued)

Undercarriage	Rear Blade (Wide U/C)						
Counterweight	3.6 mt				4.2 mt		
Boom Type	1 PC		VA		1 PC		VA
Stick Length	2.50 m (8'2")	2.90 m (9'6")	2.50 m (8'2")	2.90 m (9'6")	2.50 m (8'2")	2.90 m (9'6")	2.50 m (8'2")
H115 S	✓	✓	✓	✓	✓	✓	✓
H120 S	✓		✓	✓	✓	✓	✓
H130 S							✓

HCS70 Dedicated Coupler

Undercarriage	Front and Rear Outriggers							
Counterweight	3.6 mt				4.2 mt			
Boom Type	1 PC		VA		1 PC		VA	
Stick Length	2.50 m (8'2")	2.90 m (9'6")	2.50 m (8'2")	2.90 m (9'6")	2.50 m (8'2")	2.90 m (9'6")	2.50 m (8'2")	2.90 m (9'6")
H115 S	✓	✓	✓	✓	✓	✓	✓	✓
H120 S	✓	✓	✓	✓	✓	✓	✓	✓
H130 S	✓	✓	✓		✓	✓	✓	

HCS70 Dedicated Coupler (continued)

Undercarriage	Front Blade; Rear Outriggers							
Counterweight	3.6 mt				4.2 mt			
Boom Type	1 PC		VA		1 PC		VA	
Stick Length	2.50 m (8'2")	2.90 m (9'6")	2.50 m (8'2")	2.90 m (9'6")	2.50 m (8'2")	2.90 m (9'6")	2.50 m (8'2")	2.90 m (9'6")
H115 S	✓	✓	✓	✓	✓	✓	✓	✓
H120 S	✓	✓	✓	✓	✓	✓	✓	✓
H130 S	✓	✓	✓		✓	✓	✓	

HCS70 Dedicated Coupler (continued)

Undercarriage	Front Outriggers; Rear Blade (Wide U/C)							
Counterweight	3.6 mt				4.2 mt			
Boom Type	1 PC		VA		1 PC		VA	
Stick Length	2.50 m (8'2")	2.90 m (9'6")	2.50 m (8'2")	2.90 m (9'6")	2.50 m (8'2")	2.90 m (9'6")	2.50 m (8'2")	2.90 m (9'6")
H115 S	✓	✓	✓	✓	✓	✓	✓	✓
H120 S	✓	✓	✓	✓	✓	✓	✓	✓
H130 S	✓	✓	✓		✓	✓	✓	

HCS70 Dedicated Coupler (continued)

Undercarriage	Front Outriggers; Rear Blade							
Counterweight	3.6 mt				4.2 mt			
Boom Type	1 PC		VA		1 PC		VA	
Stick Length	2.50 m (8'2")	2.90 m (9'6")	2.50 m (8'2")	2.90 m (9'6")	2.50 m (8'2")	2.90 m (9'6")	2.50 m (8'2")	2.90 m (9'6")
H115 S	✓	✓	✓	✓	✓	✓	✓	✓
H120 S	✓	✓	✓	✓	✓	✓	✓	✓
H130 S	✓	✓	✓		✓	✓	✓	

(continued on next page)

Matching – Wheeled Excavators *(continued)*

Match
 * Working Range Front Only
 † Allowed Usage on Machine Less Than 50%
 No Match

M320 *(continued)*

HCS70 Dedicated Coupler *(continued)*

Undercarriage	Rear Blade							
Counterweight	3.6 mt				4.2 mt			
Boom Type	1 PC		VA		1 PC		VA	
Stick Length	2.50 m (8'2")	2.90 m (9'6")	2.50 m (8'2")	2.90 m (9'6")	2.50 m (8'2")	2.90 m (9'6")	2.50 m (8'2")	2.90 m (9'6")
H115 S	✓	✓	✓	✓	✓	✓	✓	✓
H120 S							✓	
H130 S								

HCS70 Dedicated Coupler *(continued)*

Undercarriage	Rear Blade (Wide U/C)							
Counterweight	3.6 mt				4.2 mt			
Boom Type	1 PC		VA		1 PC		VA	
Stick Length	2.50 m (8'2")	2.90 m (9'6")	2.50 m (8'2")	2.90 m (9'6")	2.50 m (8'2")	2.90 m (9'6")	2.50 m (8'2")	2.90 m (9'6")
H115 S	✓	✓	✓	✓	✓	✓	✓	✓
H120 S			✓		✓	✓	✓	✓
H130 S							✓	

HCS70-55 Dedicated Coupler

Undercarriage	Front and Rear Outriggers							
Counterweight	3.6 mt				4.2 mt			
Boom Type	1 PC		VA		1 PC		VA	
Stick Length	2.50 m (8'2")	2.90 m (9'6")	2.50 m (8'2")	2.90 m (9'6")	2.50 m (8'2")	2.90 m (9'6")	2.50 m (8'2")	2.90 m (9'6")
H115 S	✓	✓	✓	✓	✓	✓	✓	✓
H120 S	✓	✓	✓	✓	✓	✓	✓	✓
H130 S	✓	✓			✓	✓		

HCS70-55 Dedicated Coupler *(continued)*

Undercarriage	Front Blade; Rear Outriggers							
Counterweight	3.6 mt				4.2 mt			
Boom Type	1 PC		VA		1 PC		VA	
Stick Length	2.50 m (8'2")	2.90 m (9'6")	2.50 m (8'2")	2.90 m (9'6")	2.50 m (8'2")	2.90 m (9'6")	2.50 m (8'2")	2.90 m (9'6")
H115 S	✓	✓	✓	✓	✓	✓	✓	✓
H120 S	✓	✓	✓	✓	✓	✓	✓	✓
H130 S	✓	✓			✓	✓		

HCS70-55 Dedicated Coupler *(continued)*

Undercarriage	Front Outriggers; Rear Blade (Wide U/C)							
Counterweight	3.6 mt				4.2 mt			
Boom Type	1 PC		VA		1 PC		VA	
Stick Length	2.50 m (8'2")	2.90 m (9'6")	2.50 m (8'2")	2.90 m (9'6")	2.50 m (8'2")	2.90 m (9'6")	2.50 m (8'2")	2.90 m (9'6")
H115 S	✓	✓	✓	✓	✓	✓	✓	✓
H120 S	✓	✓	✓	✓	✓	✓	✓	✓
H130 S	✓	✓			✓	✓		

(continued on next page)

Hammer Technical Specifications

Matching – Wheeled Excavators (continued)

Match
 Working Range Front Only
 Allowed Usage on Machine Less Than 50%
 No Match

M320 (continued)

HCS70-55 Dedicated Coupler (continued)

Undercarriage	Front Outriggers; Rear Blade							
Counterweight	3.6 mt				4.2 mt			
Boom Type	1 PC		VA		1 PC		VA	
Stick Length	2.50 m (8'2")	2.90 m (9'6")	2.50 m (8'2")	2.90 m (9'6")	2.50 m (8'2")	2.90 m (9'6")	2.50 m (8'2")	2.90 m (9'6")
H115 S	✓	✓	✓	✓	✓	✓	✓	✓
H120 S	✓	✓	✓	✓	✓	✓	✓	✓
H130 S	✓	✓			✓	✓		

HCS70-55 Dedicated Coupler (continued)

Undercarriage	Rear Blade							
Counterweight	3.6 mt				4.2 mt			
Boom Type	1 PC		VA		1 PC		VA	
Stick Length	2.50 m (8'2")	2.90 m (9'6")	2.50 m (8'2")	2.90 m (9'6")	2.50 m (8'2")	2.90 m (9'6")	2.50 m (8'2")	2.90 m (9'6")
H115 S	✓	✓	✓	✓	✓	✓	✓	✓
H120 S							✓	
H130 S								

HCS70-55 Dedicated Coupler (continued)

Undercarriage	Rear Blade (Wide U/C)							
Counterweight	3.6 mt				4.2 mt			
Boom Type	1 PC		VA		1 PC		VA	
Stick Length	2.50 m (8'2")	2.90 m (9'6")	2.50 m (8'2")	2.90 m (9'6")	2.50 m (8'2")	2.90 m (9'6")	2.50 m (8'2")	2.90 m (9'6")
H115 S	✓	✓	✓	✓	✓	✓	✓	✓
H120 S			✓		✓		✓	✓
H130 S								

Tilt-Rotator TRS18 with CW30 S Dedicated Coupler

Undercarriage	Front and Rear Outriggers							
Counterweight	3.6 mt				4.2 mt			
Boom Type	1 PC		VA		1 PC		VA	
Stick Length	2.50 m (8'2")	2.90 m (9'6")	2.50 m (8'2")	2.90 m (9'6")	2.50 m (8'2")	2.90 m (9'6")	2.50 m (8'2")	2.90 m (9'6")
H115 S	✓	✓	✓	✓	✓	✓	✓	✓

Tilt-Rotator TRS18 with CW30 S Dedicated Coupler (continued)

Undercarriage	Front Blade; Rear Outriggers							
Counterweight	3.6 mt				4.2 mt			
Boom Type	1 PC		VA		1 PC		VA	
Stick Length	2.50 m (8'2")	2.90 m (9'6")	2.50 m (8'2")	2.90 m (9'6")	2.50 m (8'2")	2.90 m (9'6")	2.50 m (8'2")	2.90 m (9'6")
H115 S	✓	✓	✓	✓	✓	✓	✓	✓

Tilt-Rotator TRS18 with CW30 S Dedicated Coupler (continued)

Undercarriage	Front Outriggers; Rear Blade (Wide U/C)							
Counterweight	3.6 mt				4.2 mt			
Boom Type	1 PC		VA		1 PC		VA	
Stick Length	2.50 m (8'2")	2.90 m (9'6")	2.50 m (8'2")	2.90 m (9'6")	2.50 m (8'2")	2.90 m (9'6")	2.50 m (8'2")	2.90 m (9'6")
H115 S	✓	✓	✓	✓	✓	✓	✓	✓

(continued on next page)

Matching – Wheeled Excavators *(continued)*

Match
 Working Range Front Only
 Allowed Usage on Machine Less Than 50%
 No Match

M320 *(continued)*

Tilt-Rotator TRS18 with CW30 S Dedicated Coupler *(continued)*

Undercarriage	Front Outriggers; Rear Blade							
	3.6 mt				4.2 mt			
	1 PC		VA		1 PC		VA	
Counterweight	2.50 m (8'2")		2.90 m (9'6")		2.50 m (8'2")		2.90 m (9'6")	
Stick Length	2.50 m (8'2")	2.90 m (9'6")	2.50 m (8'2")	2.90 m (9'6")	2.50 m (8'2")	2.90 m (9'6")	2.50 m (8'2")	2.90 m (9'6")
H115 S	✓	✓	✓	✓	✓	✓	✓	✓

Tilt-Rotator TRS18 with CW30 S Dedicated Coupler *(continued)*

Undercarriage	Rear Blade		
	4.2 mt		
	1 PC	VA	
Counterweight	2.50 m (8'2")		2.90 m (9'6")
Stick Length	2.50 m (8'2")	2.50 m (8'2")	2.90 m (9'6")
H115 S	✓	✓	✓

Tilt-Rotator TRS18 with CW30 S Dedicated Coupler *(continued)*

Undercarriage	Rear Blade (Wide U/C)							
	3.6 mt			4.2 mt				
	1 PC	VA		1 PC		VA		
Counterweight	2.50 m (8'2")		2.50 m (8'2")		2.90 m (9'6")		2.90 m (9'6")	
Stick Length	2.50 m (8'2")	2.50 m (8'2")	2.90 m (9'6")	2.50 m (8'2")	2.90 m (9'6")	2.50 m (8'2")	2.90 m (9'6")	
H115 S	✓	✓	✓	✓	✓	✓	✓	

CW30 S – Tilt-Rotator TRS18 – CW30 S

Undercarriage	Front and Rear Outriggers					
	3.6 mt			4.2 mt		
	1 PC		VA	1 PC		VA
Counterweight	2.50 m (8'2")		2.90 m (9'6")	2.50 m (8'2")		2.50 m (8'2")
Stick Length	2.50 m (8'2")	2.90 m (9'6")	2.50 m (8'2")	2.50 m (8'2")	2.90 m (9'6")	2.50 m (8'2")
H115 S	✓	✓	✓	✓	✓	✓

CW30 S – Tilt-Rotator TRS18 – CW30 S *(continued)*

Undercarriage	Front Blade; Rear Outriggers					
	3.6 mt			4.2 mt		
	1 PC		VA	1 PC		VA
Counterweight	2.50 m (8'2")		2.90 m (9'6")	2.50 m (8'2")		2.50 m (8'2")
Stick Length	2.50 m (8'2")	2.90 m (9'6")	2.50 m (8'2")	2.50 m (8'2")	2.90 m (9'6")	2.50 m (8'2")
H115 S	✓	✓	✓	✓	✓	✓

CW30 S – Tilt-Rotator TRS18 – CW30 S *(continued)*

Undercarriage	Front Outriggers; Rear Blade (Wide U/C)					
	3.6 mt			4.2 mt		
	1 PC		VA	1 PC		VA
Counterweight	2.50 m (8'2")		2.90 m (9'6")	2.50 m (8'2")		2.50 m (8'2")
Stick Length	2.50 m (8'2")	2.90 m (9'6")	2.50 m (8'2")	2.50 m (8'2")	2.90 m (9'6")	2.50 m (8'2")
H115 S	✓	✓	✓	✓	✓	✓

CW30 S – Tilt-Rotator TRS18 – CW30 S *(continued)*

Undercarriage	Front Outriggers; Rear Blade						Rear Blade (Wide U/C)	
	3.6 mt			4.2 mt			4.2 mt	
	1 PC		VA	1 PC		VA	1 PC	VA
Counterweight	2.50 m (8'2")		2.90 m (9'6")	2.50 m (8'2")		2.50 m (8'2")	2.50 m (8'2")	2.50 m (8'2")
Stick Length	2.50 m (8'2")	2.90 m (9'6")	2.50 m (8'2")	2.50 m (8'2")	2.90 m (9'6")	2.50 m (8'2")	2.50 m (8'2")	
H115 S	✓	✓	✓	✓	✓	✓	✓	

(continued on next page)

Hammer Technical Specifications

Matching – Wheeled Excavators (continued)

Match
 Working Range Front Only
 Allowed Usage on Machine Less Than 50%
 No Match

M320 (continued)

Tilt-Rotator TRS18 with CW30 Dedicated Coupler

Undercarriage	Front and Rear Outriggers							
	3.6 mt				4.2 mt			
Counterweight	1 PC		VA		1 PC		VA	
Boom Type	1 PC		VA		1 PC		VA	
Stick Length	2.50 m (8'2")	2.90 m (9'6")	2.50 m (8'2")	2.90 m (9'6")	2.50 m (8'2")	2.90 m (9'6")	2.50 m (8'2")	2.90 m (9'6")
H115 S	✓	✓	✓	✓	✓	✓	✓	✓

Tilt-Rotator TRS18 with CW30 Dedicated Coupler (continued)

Undercarriage	Front Blade; Rear Outriggers							
	3.6 mt				4.2 mt			
Counterweight	1 PC		VA		1 PC		VA	
Boom Type	1 PC		VA		1 PC		VA	
Stick Length	2.50 m (8'2")	2.90 m (9'6")	2.50 m (8'2")	2.90 m (9'6")	2.50 m (8'2")	2.90 m (9'6")	2.50 m (8'2")	2.90 m (9'6")
H115 S	✓	✓	✓	✓	✓	✓	✓	✓

Tilt-Rotator TRS18 with CW30 Dedicated Coupler (continued)

Undercarriage	Front Outriggers; Rear Blade (Wide U/C)							
	3.6 mt				4.2 mt			
Counterweight	1 PC		VA		1 PC		VA	
Boom Type	1 PC		VA		1 PC		VA	
Stick Length	2.50 m (8'2")	2.90 m (9'6")	2.50 m (8'2")	2.90 m (9'6")	2.50 m (8'2")	2.90 m (9'6")	2.50 m (8'2")	2.90 m (9'6")
H115 S	✓	✓	✓	✓	✓	✓	✓	✓

Tilt-Rotator TRS18 with CW30 Dedicated Coupler (continued)

Undercarriage	Front Outriggers; Rear Blade							
	3.6 mt				4.2 mt			
Counterweight	1 PC		VA		1 PC		VA	
Boom Type	1 PC		VA		1 PC		VA	
Stick Length	2.50 m (8'2")	2.90 m (9'6")	2.50 m (8'2")	2.90 m (9'6")	2.50 m (8'2")	2.90 m (9'6")	2.50 m (8'2")	2.90 m (9'6")
H115 S	✓	✓	✓	✓	✓	✓	✓	✓

Tilt-Rotator TRS18 with CW30 Dedicated Coupler (continued)

Undercarriage	Rear Blade	Rear Blade (Wide U/C)					
	4.2 mt	3.6 mt	4.2 mt				
Counterweight	VA	VA	1 PC		VA		
Boom Type	VA	VA	1 PC		VA		
Stick Length	2.50 m (8'2")	2.50 m (8'2")	2.50 m (8'2")	2.90 m (9'6")	2.50 m (8'2")	2.90 m (9'6")	
H115 S	✓	✓	✓	✓	✓	✓	

CW30 – Tilt-Rotator TRS18 – CW30

Undercarriage	Front and Rear Outriggers					
	3.6 mt			4.2 mt		
Counterweight	1 PC		VA	1 PC		VA
Boom Type	1 PC		VA	1 PC		VA
Stick Length	2.50 m (8'2")	2.90 m (9'6")	2.50 m (8'2")	2.50 m (8'2")	2.90 m (9'6")	2.50 m (8'2")
H115 S	✓	✓	✓	✓	✓	✓

CW30 – Tilt-Rotator TRS18 – CW30 (continued)

Undercarriage	Front Blade; Rear Outriggers					
	3.6 mt			4.2 mt		
Counterweight	1 PC		VA	1 PC		VA
Boom Type	1 PC		VA	1 PC		VA
Stick Length	2.50 m (8'2")	2.90 m (9'6")	2.50 m (8'2")	2.50 m (8'2")	2.90 m (9'6")	2.50 m (8'2")
H115 S	✓	✓	✓	✓	✓	✓

(continued on next page)

Matching – Wheeled Excavators (continued)

Match
 Working Range Front Only
 Allowed Usage on Machine Less Than 50%
 No Match

M320 (continued)

CW30 – Tilt-Rotator TRS18 – CW30 (continued)

Undercarriage	Front Outriggers; Rear Blade (Wide U/C)					
	3.6 mt			4.2 mt		
Counterweight	3.6 mt			4.2 mt		
Boom Type	1 PC		VA	1 PC		VA
Stick Length	2.50 m (8'2")	2.90 m (9'6")	2.50 m (8'2")	2.50 m (8'2")	2.90 m (9'6")	2.50 m (8'2")
H115 S	✓	✓	✓	✓	✓	✓

CW30 – Tilt-Rotator TRS18 – CW30 (continued)

Undercarriage	Front Outriggers; Rear Blade						Rear Blade (Wide U/C)
	3.6 mt			4.2 mt			4.2 mt
Counterweight	3.6 mt			4.2 mt			4.2 mt
Boom Type	1 PC		VA	1 PC		VA	VA
Stick Length	2.50 m (8'2")	2.90 m (9'6")	2.50 m (8'2")	2.50 m (8'2")	2.90 m (9'6")	2.50 m (8'2")	2.50 m (8'2")
H115 S	✓	✓	✓	✓	✓	✓	✓

Tilt-Rotator TRS18 with S70 Dedicated Coupler

Undercarriage	Front and Rear Outriggers		Front Blade; Rear Outriggers		Front Outriggers; Rear Blade (Wide U/C)		Front Outriggers; Rear Blade	
	4.8 mt		4.8 mt		4.8 mt		4.8 mt	
Counterweight	4.8 mt		4.8 mt		4.8 mt		4.8 mt	
Boom Type	1 PC		1 PC		1 PC		1 PC	
Stick Length	2.50 m (8'2")	2.90 m (9'6")	2.50 m (8'2")	2.90 m (9'6")	2.50 m (8'2")	2.90 m (9'6")	2.50 m (8'2")	2.90 m (9'6")
H115 S	✓	✓	✓	✓	✓	✓	✓	✓

Tilt-Rotator TRS18 with S70 Dedicated Coupler (continued)

Undercarriage	Rear Blade		Rear Blade (Wide U/C)		Front and Rear Outriggers	
	4.8 mt		4.8 mt		3.6 mt	
Counterweight	4.8 mt		4.8 mt		3.6 mt	
Boom Type	1 PC		1 PC		1 PC	
Stick Length	2.50 m (8'2")	2.90 m (9'6")	2.50 m (8'2")	2.90 m (9'6")	2.50 m (8'2")	2.90 m (9'6")
H115 S	✓	✓	✓	✓	✓	✓

S70 – Tilt-Rotator TRS18 – S70

Undercarriage	Front and Rear Outriggers					
	3.6 mt			4.2 mt		
Counterweight	3.6 mt			4.2 mt		
Boom Type	1 PC		VA	1 PC		VA
Stick Length	2.50 m (8'2")	2.90 m (9'6")	2.50 m (8'2")	2.50 m (8'2")	2.90 m (9'6")	2.50 m (8'2")
H115 S	✓	✓	✓	✓	✓	✓

S70 – Tilt-Rotator TRS18 – S70 (continued)

Undercarriage	Front Blade; Rear Outriggers					
	3.6 mt			4.2 mt		
Counterweight	3.6 mt			4.2 mt		
Boom Type	1 PC		VA	1 PC		VA
Stick Length	2.50 m (8'2")	2.90 m (9'6")	2.50 m (8'2")	2.50 m (8'2")	2.90 m (9'6")	2.50 m (8'2")
H115 S	✓	✓	✓	✓	✓	✓

S70 – Tilt-Rotator TRS18 – S70 (continued)

Undercarriage	Front Outriggers; Rear Blade (Wide U/C)					
	3.6 mt			4.2 mt		
Counterweight	3.6 mt			4.2 mt		
Boom Type	1 PC		VA	1 PC		VA
Stick Length	2.50 m (8'2")	2.90 m (9'6")	2.50 m (8'2")	2.50 m (8'2")	2.90 m (9'6")	2.50 m (8'2")
H115 S	✓	✓	✓	✓	✓	✓

(continued on next page)

Hammer Technical Specifications

Matching – Wheeled Excavators (continued)

Match
 * Working Range Front Only
 † Allowed Usage on Machine Less Than 50%
 No Match

M320 (continued)

S70 – Tilt-Rotator TRS18 – S70 (continued)

Undercarriage	Front Outriggers; Rear Blade						Rear Blade (Wide U/C)
Counterweight	3.6 mt			4.2 mt			4.2 mt
Boom Type	1 PC		VA	1 PC		VA	VA
Stick Length	2.50 m (8'2")	2.90 m (9'6")	2.50 m (8'2")	2.50 m (8'2")	2.90 m (9'6")	2.50 m (8'2")	2.50 m (8'2")
H115 S	✓	✓	✓	✓	✓	✓	✓

Tilt-Rotator TRS18 with HCS70 Dedicated Coupler

Undercarriage	Front and Rear Outriggers							
Counterweight	3.6 mt				4.2 mt			
Boom Type	1 PC		VA		1 PC		VA	
Stick Length	2.50 m (8'2")	2.90 m (9'6")	2.50 m (8'2")	2.90 m (9'6")	2.50 m (8'2")	2.90 m (9'6")	2.50 m (8'2")	2.90 m (9'6")
H115 S	✓	✓	✓	✓	✓	✓	✓	✓

Tilt-Rotator TRS18 with HCS70 Dedicated Coupler (continued)

Undercarriage	Front Blade; Rear Outriggers							
Counterweight	3.6 mt				4.2 mt			
Boom Type	1 PC		VA		1 PC		VA	
Stick Length	2.50 m (8'2")	2.90 m (9'6")	2.50 m (8'2")	2.90 m (9'6")	2.50 m (8'2")	2.90 m (9'6")	2.50 m (8'2")	2.90 m (9'6")
H115 S	✓	✓	✓	✓	✓	✓	✓	✓

Tilt-Rotator TRS18 with HCS70 Dedicated Coupler (continued)

Undercarriage	Front Outriggers; Rear Blade (Wide U/C)							
Counterweight	3.6 mt				4.2 mt			
Boom Type	1 PC		VA		1 PC		VA	
Stick Length	2.50 m (8'2")	2.90 m (9'6")	2.50 m (8'2")	2.90 m (9'6")	2.50 m (8'2")	2.90 m (9'6")	2.50 m (8'2")	2.90 m (9'6")
H115 S	✓	✓	✓	✓	✓	✓	✓	✓

Tilt-Rotator TRS18 with HCS70 Dedicated Coupler (continued)

Undercarriage	Front Outriggers; Rear Blade							
Counterweight	3.6 mt				4.2 mt			
Boom Type	1 PC		VA		1 PC		VA	
Stick Length	2.50 m (8'2")	2.90 m (9'6")	2.50 m (8'2")	2.90 m (9'6")	2.50 m (8'2")	2.90 m (9'6")	2.50 m (8'2")	2.90 m (9'6")
H115 S	✓	✓	✓	✓	✓	✓	✓	✓

Tilt-Rotator TRS18 with HCS70 Dedicated Coupler (continued)

Undercarriage	Rear Blade	Rear Blade (Wide U/C)					
Counterweight	4.2 mt	3.6 mt	4.2 mt				
Boom Type	VA	VA	1 PC		VA		
Stick Length	2.50 m (8'2")	2.50 m (8'2")	2.50 m (8'2")	2.90 m (9'6")	2.50 m (8'2")	2.90 m (9'6")	
H115 S	✓	✓	✓	✓	✓	✓	

HCS70 – Tilt-Rotator TRS18 – HCS70

Undercarriage	Front and Rear Outriggers				Front Blade; Rear Outriggers			
Counterweight	3.6 mt		4.2 mt		3.6 mt		4.2 mt	
Boom Type	1 PC		1 PC		1 PC		1 PC	
Stick Length	2.50 m (8'2")	2.90 m (9'6")	2.50 m (8'2")	2.90 m (9'6")	2.50 m (8'2")	2.90 m (9'6")	2.50 m (8'2")	2.90 m (9'6")
H115 S	✓	✓	✓	✓	✓	✓	✓	✓

(continued on next page)

Matching – Wheeled Excavators *(continued)*

Match
 Working Range Front Only
 Allowed Usage on Machine Less Than 50%
 No Match

M320 *(continued)*

HCS70 – Tilt-Rotator TRS18 – HCS70 *(continued)*

Undercarriage	Front Outriggers; Rear Blade (Wide U/C)				Front Outriggers; Rear Blade			
	3.6 mt		4.2 mt		3.6 mt		4.2 mt	
Counterweight	3.6 mt		4.2 mt		3.6 mt		4.2 mt	
Boom Type	1 PC		1 PC		1 PC		1 PC	
Stick Length	2.50 m (8'2")	2.90 m (9'6")	2.50 m (8'2")	2.90 m (9'6")	2.50 m (8'2")	2.90 m (9'6")	2.50 m (8'2")	2.90 m (9'6")
H115 S	✓	✓	✓	✓	✓	✓	✓	✓

Tilt-Rotator TRS18 with HCS70-55 Dedicated Coupler

Undercarriage	Front and Rear Outriggers					
	3.6 mt			4.2 mt		
Counterweight	3.6 mt			4.2 mt		
Boom Type	1 PC		VA	1 PC		VA
Stick Length	2.50 m (8'2")	2.90 m (9'6")	2.50 m (8'2")	2.50 m (8'2")	2.90 m (9'6")	2.50 m (8'2")
H115 S	✓	✓	✓	✓	✓	✓

Tilt-Rotator TRS18 with HCS70-55 Dedicated Coupler *(continued)*

Undercarriage	Front Blade; Rear Outriggers					
	3.6 mt			4.2 mt		
Counterweight	3.6 mt			4.2 mt		
Boom Type	1 PC		VA	1 PC		VA
Stick Length	2.50 m (8'2")	2.90 m (9'6")	2.50 m (8'2")	2.50 m (8'2")	2.90 m (9'6")	2.50 m (8'2")
H115 S	✓	✓	✓	✓	✓	✓

Tilt-Rotator TRS18 with HCS70-55 Dedicated Coupler *(continued)*

Undercarriage	Front Outriggers; Rear Blade (Wide U/C)					
	3.6 mt			4.2 mt		
Counterweight	3.6 mt			4.2 mt		
Boom Type	1 PC		VA	1 PC		VA
Stick Length	2.50 m (8'2")	2.90 m (9'6")	2.50 m (8'2")	2.50 m (8'2")	2.90 m (9'6")	2.50 m (8'2")
H115 S	✓	✓	✓	✓	✓	✓

Tilt-Rotator TRS18 with HCS70-55 Dedicated Coupler *(continued)*

Undercarriage	Front Outriggers; Rear Blade					
	3.6 mt			4.2 mt		
Counterweight	3.6 mt			4.2 mt		
Boom Type	1 PC		VA	1 PC		VA
Stick Length	2.50 m (8'2")	2.90 m (9'6")	2.50 m (8'2")	2.50 m (8'2")	2.90 m (9'6")	2.50 m (8'2")
H115 S	✓	✓	✓	✓	✓	✓

Tilt-Rotator TRS18 with HCS70-55 Dedicated Coupler *(continued)*

Undercarriage	Rear Blade	Rear Blade (Wide U/C)		
	4.2 mt	3.6 mt	4.2 mt	
Counterweight	4.2 mt	3.6 mt	4.2 mt	
Boom Type	VA	VA	1 PC	VA
Stick Length	2.50 m (8'2")	2.50 m (8'2")	2.50 m (8'2")	2.50 m (8'2")
H115 S	✓	✓	✓	✓

HCS70-55 – TRS18 – HCS70-55

Undercarriage	Front and Rear Outriggers		Front Blade; Rear Outriggers		Front Outriggers; Rear Blade (Wide U/C)		Front Outriggers; Rear Blade	
	3.6 mt	4.2 mt	3.6 mt	4.2 mt	3.6 mt	4.2 mt	3.6 mt	4.2 mt
Counterweight	3.6 mt	4.2 mt	3.6 mt	4.2 mt	3.6 mt	4.2 mt	3.6 mt	4.2 mt
Boom Type	1 PC	1 PC	1 PC	1 PC	1 PC	1 PC	1 PC	1 PC
Stick Length	2.50 m (8'2")	2.50 m (8'2")	2.50 m (8'2")	2.50 m (8'2")	2.50 m (8'2")	2.50 m (8'2")	2.50 m (8'2")	2.50 m (8'2")
H115 S	✓	✓	✓	✓	✓	✓	✓	✓

(continued on next page)

Hammer Technical Specifications

Matching – Wheeled Excavators (continued)

Match
 Working Range Front Only
 Allowed Usage on Machine Less Than 50%
 No Match

M322D2

Pin-on

Undercarriage	Front and Rear Outriggers					
Counterweight	3.9 mt					
Boom Type	1 PC			VA		
Stick Length	2.20 m (7'3")	2.50 m (8'2")	2.90 m (9'6")	2.20 m (7'3")	2.50 m (8'2")	2.90 m (9'6")
H115 S	✓	✓	✓	✓	✓	✓
H120 S	✓	✓	✓	✓	✓	✓
H130 S	✓	✓		✓	✓	

Pin-on (continued)

Undercarriage	Front and Rear Outriggers					
Counterweight	4.4 mt					
Boom Type	1 PC			VA		
Stick Length	2.20 m (7'3")	2.50 m (8'2")	2.90 m (9'6")	2.20 m (7'3")	2.50 m (8'2")	2.90 m (9'6")
H115 S	✓	✓	✓	✓	✓	✓
H120 S	✓	✓	✓	✓	✓	✓
H130 S	✓	✓		✓	✓	

Pin-on (continued)

Undercarriage	Front and Rear Outriggers					
Counterweight	5.4 mt					
Boom Type	1 PC			VA		
Stick Length	2.20 m (7'3")	2.50 m (8'2")	2.90 m (9'6")	2.20 m (7'3")	2.50 m (8'2")	2.90 m (9'6")
H115 S	✓	✓	✓	✓	✓	✓
H120 S	✓	✓	✓	✓	✓	✓
H130 S	✓	✓		✓	✓	

Pin-on (continued)

Undercarriage	Front Outriggers; Rear Blade					
Counterweight	3.9 mt					
Boom Type	1 PC			VA		
Stick Length	2.20 m (7'3")	2.50 m (8'2")	2.90 m (9'6")	2.20 m (7'3")	2.50 m (8'2")	2.90 m (9'6")
H115 S	✓	✓	✓	✓	✓	✓
H120 S	✓	✓	✓	✓	✓	✓
H130 S	✓	✓		✓	✓	

Pin-on (continued)

Undercarriage	Front Outriggers; Rear Blade					
Counterweight	4.4 mt					
Boom Type	1 PC			VA		
Stick Length	2.20 m (7'3")	2.50 m (8'2")	2.90 m (9'6")	2.20 m (7'3")	2.50 m (8'2")	2.90 m (9'6")
H115 S	✓	✓	✓	✓	✓	✓
H120 S	✓	✓	✓	✓	✓	✓
H130 S	✓	✓		✓	✓	

(continued on next page)

Matching – Wheeled Excavators (continued)

Match
 * Working Range Front Only
 † Allowed Usage on Machine Less Than 50%
 No Match

M322D2 (continued)

Pin-on (continued)

Undercarriage	Front Outriggers; Rear Blade					
Counterweight	5.4 mt					
Boom Type	1 PC			VA		
Stick Length	2.20 m (7'3")	2.50 m (8'2")	2.90 m (9'6")	2.20 m (7'3")	2.50 m (8'2")	2.90 m (9'6")
H115 S	✓	✓	✓	✓	✓	✓
H120 S	✓	✓	✓	✓	✓	✓
H130 S	✓	✓		✓	✓	

Pin-on (continued)

Undercarriage	Rear Blade					
Counterweight	3.9 mt					
Boom Type	1 PC			VA		
Stick Length	2.20 m (7'3")	2.50 m (8'2")	2.90 m (9'6")	2.20 m (7'3")	2.50 m (8'2")	2.90 m (9'6")
H115 S	✓	✓	✓	✓	✓	✓
H120 S	✓	✓	✓	✓	✓	✓
H130 S	✓	✓*		✓	✓*	

Pin-on (continued)

Undercarriage	Rear Blade					
Counterweight	4.4 mt					
Boom Type	1 PC			VA		
Stick Length	2.20 m (7'3")	2.50 m (8'2")	2.90 m (9'6")	2.20 m (7'3")	2.50 m (8'2")	2.90 m (9'6")
H115 S	✓	✓	✓	✓	✓	✓
H120 S	✓	✓	✓	✓	✓	✓
H130 S	✓	✓		✓	✓	

Pin-on (continued)

Undercarriage	Rear Blade					
Counterweight	5.4 mt					
Boom Type	1 PC			VA		
Stick Length	2.20 m (7'3")	2.50 m (8'2")	2.90 m (9'6")	2.20 m (7'3")	2.50 m (8'2")	2.90 m (9'6")
H115 S	✓	✓	✓	✓	✓	✓
H120 S	✓	✓	✓	✓	✓	✓
H130 S	✓	✓		✓	✓	

Cat Pin Grabber Coupler

Undercarriage	Front and Rear Outriggers					
Counterweight	3.9 mt					
Boom Type	1 PC			VA		
Stick Length	2.20 m (7'3")	2.50 m (8'2")	2.90 m (9'6")	2.20 m (7'3")	2.50 m (8'2")	2.90 m (9'6")
H115 S	✓	✓	✓	✓	✓	✓
H120 S	✓	✓	✓	✓	✓	✓
H130 S	✓	✓		✓	✓	

(continued on next page)

Hammer Technical Specifications

Matching – Wheeled Excavators (continued)

Match
 Working Range Front Only
 Allowed Usage on Machine Less Than 50%
 No Match

M322D2 (continued)

Cat Pin Grabber Coupler (continued)

Undercarriage	Front and Rear Outriggers					
Counterweight	4.4 mt					
Boom Type	1 PC			VA		
Stick Length	2.20 m (7'3")	2.50 m (8'2")	2.90 m (9'6")	2.20 m (7'3")	2.50 m (8'2")	2.90 m (9'6")
H115 S	✓	✓	✓	✓	✓	✓
H120 S	✓	✓	✓	✓	✓	✓
H130 S	✓	✓		✓	✓	

Cat Pin Grabber Coupler (continued)

Undercarriage	Front and Rear Outriggers					
Counterweight	5.4 mt					
Boom Type	1 PC			VA		
Stick Length	2.20 m (7'3")	2.50 m (8'2")	2.90 m (9'6")	2.20 m (7'3")	2.50 m (8'2")	2.90 m (9'6")
H115 S	✓	✓	✓	✓	✓	✓
H120 S	✓	✓	✓	✓	✓	✓
H130 S	✓	✓		✓	✓	

Cat Pin Grabber Coupler (continued)

Undercarriage	Front Outriggers; Rear Blade					
Counterweight	3.9 mt					
Boom Type	1 PC			VA		
Stick Length	2.20 m (7'3")	2.50 m (8'2")	2.90 m (9'6")	2.20 m (7'3")	2.50 m (8'2")	2.90 m (9'6")
H115 S	✓	✓	✓	✓	✓	✓
H120 S	✓	✓	✓	✓	✓	✓
H130 S	✓	✓		✓	✓	

Cat Pin Grabber Coupler (continued)

Undercarriage	Front Outriggers; Rear Blade					
Counterweight	4.4 mt					
Boom Type	1 PC			VA		
Stick Length	2.20 m (7'3")	2.50 m (8'2")	2.90 m (9'6")	2.20 m (7'3")	2.50 m (8'2")	2.90 m (9'6")
H115 S	✓	✓	✓	✓	✓	✓
H120 S	✓	✓	✓	✓	✓	✓
H130 S	✓	✓		✓	✓	

Cat Pin Grabber Coupler (continued)

Undercarriage	Front Outriggers; Rear Blade					
Counterweight	5.4 mt					
Boom Type	1 PC			VA		
Stick Length	2.20 m (7'3")	2.50 m (8'2")	2.90 m (9'6")	2.20 m (7'3")	2.50 m (8'2")	2.90 m (9'6")
H115 S	✓	✓	✓	✓	✓	✓
H120 S	✓	✓	✓	✓	✓	✓
H130 S	✓	✓		✓	✓	

(continued on next page)

Matching – Wheeled Excavators *(continued)*

Match
 Working Range Front Only
 † Allowed Usage on Machine Less Than 50%
 No Match

M322D2 *(continued)*

Cat Pin Grabber Coupler *(continued)*

Undercarriage	Rear Blade					
Counterweight	3.9 mt					
Boom Type	1 PC			VA		
Stick Length	2.20 m (7'3")	2.50 m (8'2")	2.90 m (9'6")	2.20 m (7'3")	2.50 m (8'2")	2.90 m (9'6")
H115 S	✓	✓	✓	✓	✓	✓
H120 S	✓*			✓*	✓*	
H130 S						

Cat Pin Grabber Coupler *(continued)*

Undercarriage	Rear Blade					
Counterweight	4.4 mt					
Boom Type	1 PC			VA		
Stick Length	2.20 m (7'3")	2.50 m (8'2")	2.90 m (9'6")	2.20 m (7'3")	2.50 m (8'2")	2.90 m (9'6")
H115 S	✓	✓	✓	✓	✓	✓
H120 S	✓	✓	✓*	✓	✓	✓*
H130 S						

Cat Pin Grabber Coupler *(continued)*

Undercarriage	Rear Blade					
Counterweight	5.4 mt					
Boom Type	1 PC			VA		
Stick Length	2.20 m (7'3")	2.50 m (8'2")	2.90 m (9'6")	2.20 m (7'3")	2.50 m (8'2")	2.90 m (9'6")
H115 S	✓	✓	✓	✓	✓	✓
H120 S	✓	✓	✓	✓	✓	✓
H130 S	✓	✓		✓	✓	

CW-40 S Dedicated Coupler

Undercarriage	Front and Rear Outriggers					
Counterweight	3.9 mt					
Boom Type	1 PC			VA		
Stick Length	2.20 m (7'3")	2.50 m (8'2")	2.90 m (9'6")	2.20 m (7'3")	2.50 m (8'2")	2.90 m (9'6")
H115 S	✓	✓	✓	✓	✓	✓
H120 S	✓	✓		✓	✓	
H130 S	✓			✓		

CW-40 S Dedicated Coupler *(continued)*

Undercarriage	Front and Rear Outriggers					
Counterweight	4.4 mt					
Boom Type	1 PC			VA		
Stick Length	2.20 m (7'3")	2.50 m (8'2")	2.90 m (9'6")	2.20 m (7'3")	2.50 m (8'2")	2.90 m (9'6")
H115 S	✓	✓	✓	✓	✓	✓
H120 S	✓	✓		✓	✓	
H130 S	✓			✓		

(continued on next page)

Hammer Technical Specifications

Matching – Wheeled Excavators (continued)

Match
 * Working Range Front Only
 † Allowed Usage on Machine Less Than 50%
 No Match

M322D2 (continued)

CW-40 S Dedicated Coupler (continued)

Undercarriage	Front and Rear Outriggers					
Counterweight	5.4 mt					
Boom Type	1 PC			VA		
Stick Length	2.20 m (7'3")	2.50 m (8'2")	2.90 m (9'6")	2.20 m (7'3")	2.50 m (8'2")	2.90 m (9'6")
H115 S	✓	✓	✓	✓	✓	✓
H120 S	✓	✓		✓	✓	
H130 S	✓			✓		

CW-40 S Dedicated Coupler (continued)

Undercarriage	Front Outriggers; Rear Blade					
Counterweight	3.9 mt					
Boom Type	1 PC			VA		
Stick Length	2.20 m (7'3")	2.50 m (8'2")	2.90 m (9'6")	2.20 m (7'3")	2.50 m (8'2")	2.90 m (9'6")
H115 S	✓	✓	✓	✓	✓	✓
H120 S	✓	✓		✓	✓	
H130 S	✓			✓		

CW-40 S Dedicated Coupler (continued)

Undercarriage	Front Outriggers; Rear Blade					
Counterweight	4.4 mt					
Boom Type	1 PC			VA		
Stick Length	2.20 m (7'3")	2.50 m (8'2")	2.90 m (9'6")	2.20 m (7'3")	2.50 m (8'2")	2.90 m (9'6")
H115 S	✓	✓	✓	✓	✓	✓
H120 S	✓	✓		✓	✓	
H130 S	✓			✓		

CW-40 S Dedicated Coupler (continued)

Undercarriage	Front Outriggers; Rear Blade					
Counterweight	5.4 mt					
Boom Type	1 PC			VA		
Stick Length	2.20 m (7'3")	2.50 m (8'2")	2.90 m (9'6")	2.20 m (7'3")	2.50 m (8'2")	2.90 m (9'6")
H115 S	✓	✓	✓	✓	✓	✓
H120 S	✓	✓		✓	✓	
H130 S	✓			✓		

CW-40 S Dedicated Coupler (continued)

Undercarriage	Rear Blade					
Counterweight	3.9 mt					
Boom Type	1 PC			VA		
Stick Length	2.20 m (7'3")	2.50 m (8'2")	2.90 m (9'6")	2.20 m (7'3")	2.50 m (8'2")	2.90 m (9'6")
H115 S	✓	✓	✓	✓	✓	✓
H120 S	✓	✓		✓	✓	
H130 S						

(continued on next page)

Matching – Wheeled Excavators *(continued)*

Match
 Working Range Front Only
 Allowed Usage on Machine Less Than 50%
 No Match

M322D2 *(continued)*

CW-40 S Dedicated Coupler *(continued)*

Undercarriage	Rear Blade					
Counterweight	4.4 mt					
Boom Type	1 PC			VA		
Stick Length	2.20 m (7'3")	2.50 m (8'2")	2.90 m (9'6")	2.20 m (7'3")	2.50 m (8'2")	2.90 m (9'6")
H115 S	✓	✓	✓	✓	✓	✓
H120 S	✓	✓		✓	✓	
H130 S	✓*			✓*		

CW-40 S Dedicated Coupler *(continued)*

Undercarriage	Rear Blade					
Counterweight	5.4 mt					
Boom Type	1 PC			VA		
Stick Length	2.20 m (7'3")	2.50 m (8'2")	2.90 m (9'6")	2.20 m (7'3")	2.50 m (8'2")	2.90 m (9'6")
H115 S	✓	✓	✓	✓	✓	✓
H120 S	✓	✓		✓	✓	
H130 S	✓			✓		

CW-40 Dedicated Coupler

Undercarriage	Front and Rear Outriggers					
Counterweight	3.9 mt					
Boom Type	1 PC			VA		
Stick Length	2.20 m (7'3")	2.50 m (8'2")	2.90 m (9'6")	2.20 m (7'3")	2.50 m (8'2")	2.90 m (9'6")
H115 S	✓	✓	✓	✓	✓	✓
H120 S	✓	✓		✓	✓	
H130 S	✓			✓		

CW-40 Dedicated Coupler *(continued)*

Undercarriage	Front and Rear Outriggers					
Counterweight	4.4 mt					
Boom Type	1 PC			VA		
Stick Length	2.20 m (7'3")	2.50 m (8'2")	2.90 m (9'6")	2.20 m (7'3")	2.50 m (8'2")	2.90 m (9'6")
H115 S	✓	✓	✓	✓	✓	✓
H120 S	✓	✓		✓	✓	
H130 S	✓			✓		

CW-40 Dedicated Coupler *(continued)*

Undercarriage	Front and Rear Outriggers					
Counterweight	5.4 mt					
Boom Type	1 PC			VA		
Stick Length	2.20 m (7'3")	2.50 m (8'2")	2.90 m (9'6")	2.20 m (7'3")	2.50 m (8'2")	2.90 m (9'6")
H115 S	✓	✓	✓	✓	✓	✓
H120 S	✓	✓		✓	✓	
H130 S	✓			✓		

(continued on next page)

Hammer Technical Specifications

Matching – Wheeled Excavators (continued)

Match
 * Working Range Front Only
 † Allowed Usage on Machine Less Than 50%
 No Match

M322D2 (continued)

CW-40 Dedicated Coupler (continued)

Undercarriage	Front Outriggers; Rear Blade					
Counterweight	3.9 mt					
Boom Type	1 PC			VA		
Stick Length	2.20 m (7'3")	2.50 m (8'2")	2.90 m (9'6")	2.20 m (7'3")	2.50 m (8'2")	2.90 m (9'6")
H115 S	✓	✓	✓	✓	✓	✓
H120 S	✓	✓		✓	✓	
H130 S	✓			✓		

CW-40 Dedicated Coupler (continued)

Undercarriage	Front Outriggers; Rear Blade					
Counterweight	4.4 mt					
Boom Type	1 PC			VA		
Stick Length	2.20 m (7'3")	2.50 m (8'2")	2.90 m (9'6")	2.20 m (7'3")	2.50 m (8'2")	2.90 m (9'6")
H115 S	✓	✓	✓	✓	✓	✓
H120 S	✓	✓		✓	✓	
H130 S	✓			✓		

CW-40 Dedicated Coupler (continued)

Undercarriage	Front Outriggers; Rear Blade					
Counterweight	5.4 mt					
Boom Type	1 PC			VA		
Stick Length	2.20 m (7'3")	2.50 m (8'2")	2.90 m (9'6")	2.20 m (7'3")	2.50 m (8'2")	2.90 m (9'6")
H115 S	✓	✓	✓	✓	✓	✓
H120 S	✓	✓		✓	✓	
H130 S	✓			✓		

CW-40 Dedicated Coupler (continued)

Undercarriage	Rear Blade					
Counterweight	3.9 mt					
Boom Type	1 PC			VA		
Stick Length	2.20 m (7'3")	2.50 m (8'2")	2.90 m (9'6")	2.20 m (7'3")	2.50 m (8'2")	2.90 m (9'6")
H115 S	✓	✓	✓	✓	✓	✓
H120 S	✓	✓*		✓	✓	
H130 S						

CW-40 Dedicated Coupler (continued)

Undercarriage	Rear Blade					
Counterweight	4.4 mt					
Boom Type	1 PC			VA		
Stick Length	2.20 m (7'3")	2.50 m (8'2")	2.90 m (9'6")	2.20 m (7'3")	2.50 m (8'2")	2.90 m (9'6")
H115 S	✓	✓	✓	✓	✓	✓
H120 S	✓	✓		✓	✓	
H130 S	✓*			✓*		

(continued on next page)

Matching – Wheeled Excavators *(continued)*

Match
 * Working Range Front Only
 † Allowed Usage on Machine Less Than 50%
 No Match

M322D2 *(continued)*

CW-40 Dedicated Coupler *(continued)*

Undercarriage	Rear Blade					
Counterweight	5.4 mt					
Boom Type	1 PC			VA		
Stick Length	2.20 m (7'3")	2.50 m (8'2")	2.90 m (9'6")	2.20 m (7'3")	2.50 m (8'2")	2.90 m (9'6")
H115 S	✓	✓	✓	✓	✓	✓
H120 S	✓	✓		✓	✓	
H130 S	✓			✓		

M322F

Pin-on

Undercarriage	Front and Rear Outriggers							
Counterweight	3.5 mt				4.7 mt			
Boom Type	1 PC		VA		1 PC		VA	
Stick Length	2.50 m (8'2")	2.90 m (9'6")	2.50 m (8'2")	2.90 m (9'6")	2.50 m (8'2")	2.90 m (9'6")	2.50 m (8'2")	2.90 m (9'6")
H115 S	✓	✓	✓	✓	✓	✓	✓	✓
H120 S	✓	✓	✓	✓	✓	✓	✓	✓
H130 S	✓	✓	✓	✓	✓	✓	✓	✓

Pin-on *(continued)*

Undercarriage	Front Blade; Rear Outriggers							
Counterweight	3.5 mt				4.7 mt			
Boom Type	1 PC		VA		1 PC		VA	
Stick Length	2.50 m (8'2")	2.90 m (9'6")	2.50 m (8'2")	2.90 m (9'6")	2.50 m (8'2")	2.90 m (9'6")	2.50 m (8'2")	2.90 m (9'6")
H115 S	✓	✓	✓	✓	✓	✓	✓	✓
H120 S	✓	✓	✓	✓	✓	✓	✓	✓
H130 S	✓	✓	✓	✓	✓	✓	✓	✓

Pin-on *(continued)*

Undercarriage	Front Outriggers; Rear Blade							
Counterweight	3.5 mt				4.7 mt			
Boom Type	1 PC		VA		1 PC		VA	
Stick Length	2.50 m (8'2")	2.90 m (9'6")	2.50 m (8'2")	2.90 m (9'6")	2.50 m (8'2")	2.90 m (9'6")	2.50 m (8'2")	2.90 m (9'6")
H115 S	✓	✓	✓	✓	✓	✓	✓	✓
H120 S	✓	✓	✓	✓	✓	✓	✓	✓
H130 S	✓	✓	✓	✓	✓	✓	✓	✓

Pin-on *(continued)*

Undercarriage	Rear Blade							
Counterweight	3.5 mt				4.7 mt			
Boom Type	1 PC		VA		1 PC		VA	
Stick Length	2.50 m (8'2")	2.90 m (9'6")	2.50 m (8'2")	2.90 m (9'6")	2.50 m (8'2")	2.90 m (9'6")	2.50 m (8'2")	2.90 m (9'6")
H115 S	✓	✓	✓	✓	✓	✓	✓	✓
H120 S	✓	✓	✓	✓	✓	✓	✓	✓
H130 S	✓		✓*		✓	✓	✓	✓

(continued on next page)

Hammer Technical Specifications

Matching – Wheeled Excavators (continued)

Match
 * Working Range Front Only
 † Allowed Usage on Machine Less Than 50%
 No Match

M322F (continued)

Cat Pin Grabber Coupler

Undercarriage	Front and Rear Outriggers							
Counterweight	3.5 mt				4.7 mt			
Boom Type	1 PC		VA		1 PC		VA	
Stick Length	2.50 m (8'2")	2.90 m (9'6")	2.50 m (8'2")	2.90 m (9'6")	2.50 m (8'2")	2.90 m (9'6")	2.50 m (8'2")	2.90 m (9'6")
H115 S	✓	✓	✓	✓	✓	✓	✓	✓
H120 S	✓	✓	✓	✓	✓	✓	✓	✓
H130 S	✓		✓		✓		✓	

Cat Pin Grabber Coupler (continued)

Undercarriage	Front Blade; Rear Outriggers							
Counterweight	3.5 mt				4.7 mt			
Boom Type	1 PC		VA		1 PC		VA	
Stick Length	2.50 m (8'2")	2.90 m (9'6")	2.50 m (8'2")	2.90 m (9'6")	2.50 m (8'2")	2.90 m (9'6")	2.50 m (8'2")	2.90 m (9'6")
H115 S	✓	✓	✓	✓	✓	✓	✓	✓
H120 S	✓	✓	✓	✓	✓	✓	✓	✓
H130 S	✓		✓		✓		✓	

Cat Pin Grabber Coupler (continued)

Undercarriage	Front Blade; Rear Outriggers							
Counterweight	3.5 mt				4.7 mt			
Boom Type	1 PC		VA		1 PC		VA	
Stick Length	2.50 m (8'2")	2.90 m (9'6")	2.50 m (8'2")	2.90 m (9'6")	2.50 m (8'2")	2.90 m (9'6")	2.50 m (8'2")	2.90 m (9'6")
H115 S	✓	✓	✓	✓	✓	✓	✓	✓
H120 S	✓	✓	✓	✓	✓	✓	✓	✓
H130 S	✓		✓		✓		✓	

Cat Pin Grabber Coupler (continued)

Undercarriage	Rear Blade							
Counterweight	3.5 mt				4.7 mt			
Boom Type	1 PC		VA		1 PC		VA	
Stick Length	2.50 m (8'2")	2.90 m (9'6")	2.50 m (8'2")	2.90 m (9'6")	2.50 m (8'2")	2.90 m (9'6")	2.50 m (8'2")	2.90 m (9'6")
H115 S	✓	✓	✓	✓	✓	✓	✓	✓
H120 S	✓*		✓*		✓	✓	✓	✓
H130 S					✓		✓	

CW-40 S Dedicated Coupler

Undercarriage	Front and Rear Outriggers							
Counterweight	3.5 mt				4.7 mt			
Boom Type	1 PC		VA		1 PC		VA	
Stick Length	2.50 m (8'2")	2.90 m (9'6")	2.50 m (8'2")	2.90 m (9'6")	2.50 m (8'2")	2.90 m (9'6")	2.50 m (8'2")	2.90 m (9'6")
H115 S	✓	✓	✓	✓	✓	✓	✓	✓
H120 S	✓	✓	✓	✓	✓	✓	✓	✓
H130 S	✓		✓		✓		✓	

(continued on next page)

Matching – Wheeled Excavators (continued)

Match
 Working Range Front Only
 † Allowed Usage on Machine Less Than 50%
 No Match

M322F (continued)

CW-40 S Dedicated Coupler (continued)

Undercarriage	Front Blade; Rear Outriggers							
Counterweight	3.5 mt				4.7 mt			
Boom Type	1 PC		VA		1 PC		VA	
Stick Length	2.50 m (8'2")	2.90 m (9'6")	2.50 m (8'2")	2.90 m (9'6")	2.50 m (8'2")	2.90 m (9'6")	2.50 m (8'2")	2.90 m (9'6")
H115 S	✓	✓	✓	✓	✓	✓	✓	✓
H120 S	✓	✓	✓	✓	✓	✓	✓	✓
H130 S	✓		✓		✓		✓	

CW-40 S Dedicated Coupler (continued)

Undercarriage	Front Blade; Rear Outriggers							
Counterweight	3.5 mt				4.7 mt			
Boom Type	1 PC		VA		1 PC		VA	
Stick Length	2.50 m (8'2")	2.90 m (9'6")	2.50 m (8'2")	2.90 m (9'6")	2.50 m (8'2")	2.90 m (9'6")	2.50 m (8'2")	2.90 m (9'6")
H115 S	✓	✓	✓	✓	✓	✓	✓	✓
H120 S	✓	✓	✓	✓	✓	✓	✓	✓
H130 S	✓		✓		✓		✓	

CW-40 S Dedicated Coupler (continued)

Undercarriage	Rear Blade							
Counterweight	3.5 mt				4.7 mt			
Boom Type	1 PC		VA		1 PC		VA	
Stick Length	2.50 m (8'2")	2.90 m (9'6")	2.50 m (8'2")	2.90 m (9'6")	2.50 m (8'2")	2.90 m (9'6")	2.50 m (8'2")	2.90 m (9'6")
H115 S	✓	✓	✓	✓	✓	✓	✓	✓
H120 S	✓	✓*	✓		✓	✓	✓	✓
H130 S					✓		✓	

CW-40 Dedicated Coupler

Undercarriage	Front and Rear Outriggers							
Counterweight	3.5 mt				4.7 mt			
Boom Type	1 PC		VA		1 PC		VA	
Stick Length	2.50 m (8'2")	2.90 m (9'6")	2.50 m (8'2")	2.90 m (9'6")	2.50 m (8'2")	2.90 m (9'6")	2.50 m (8'2")	2.90 m (9'6")
H115 S	✓	✓	✓	✓	✓	✓	✓	✓
H120 S	✓	✓	✓	✓	✓	✓	✓	✓
H130 S	✓		✓		✓		✓	

CW-40 Dedicated Coupler (continued)

Undercarriage	Front Blade; Rear Outriggers							
Counterweight	3.5 mt				4.7 mt			
Boom Type	1 PC		VA		1 PC		VA	
Stick Length	2.50 m (8'2")	2.90 m (9'6")	2.50 m (8'2")	2.90 m (9'6")	2.50 m (8'2")	2.90 m (9'6")	2.50 m (8'2")	2.90 m (9'6")
H115 S	✓	✓	✓	✓	✓	✓	✓	✓
H120 S	✓	✓	✓	✓	✓	✓	✓	✓
H130 S	✓		✓		✓		✓	

(continued on next page)

Hammer Technical Specifications

Matching – Wheeled Excavators (continued)

Match
 Working Range Front Only
 Allowed Usage on Machine Less Than 50%
 No Match

M322F (continued)

CW-40 Dedicated Coupler (continued)

Undercarriage	Front Outriggers; Rear Blade							
Counterweight	3.5 mt				4.7 mt			
Boom Type	1 PC		VA		1 PC		VA	
Stick Length	2.50 m (8'2")	2.90 m (9'6")	2.50 m (8'2")	2.90 m (9'6")	2.50 m (8'2")	2.90 m (9'6")	2.50 m (8'2")	2.90 m (9'6")
H115 S	✓	✓	✓	✓	✓	✓	✓	✓
H120 S	✓	✓	✓	✓	✓	✓	✓	✓
H130 S	✓		✓		✓		✓	

CW-40 Dedicated Coupler (continued)

Undercarriage	Rear Blade							
Counterweight	3.5 mt				4.7 mt			
Boom Type	1 PC		VA		1 PC		VA	
Stick Length	2.50 m (8'2")	2.90 m (9'6")	2.50 m (8'2")	2.90 m (9'6")	2.50 m (8'2")	2.90 m (9'6")	2.50 m (8'2")	2.90 m (9'6")
H115 S	✓	✓	✓	✓	✓	✓	✓	✓
H120 S	✓	✓*	✓		✓	✓	✓	✓
H130 S					✓		✓	

M322

Pin-on

Undercarriage	Front and Rear Outriggers				Front Blade; Rear Outriggers			
Counterweight	3.5 mt		4.7 mt		3.5 mt		4.7 mt	
Boom Type	VA		VA		VA		VA	
Stick Length	2.50 m (8'2")	2.90 m (9'6")	2.50 m (8'2")	2.90 m (9'6")	2.50 m (8'2")	2.90 m (9'6")	2.50 m (8'2")	2.90 m (9'6")
H115 S	✓	✓	✓	✓	✓	✓	✓	✓
H120 S	✓	✓	✓	✓	✓	✓	✓	✓
H130 S	✓	✓	✓	✓	✓	✓	✓	✓

Pin-on (continued)

Undercarriage	Front Outriggers; Rear Blade				Rear Blade			
Counterweight	3.5 mt		4.7 mt		3.5 mt		4.7 mt	
Boom Type	VA		VA		VA		VA	
Stick Length	2.50 m (8'2")	2.90 m (9'6")	2.50 m (8'2")	2.90 m (9'6")	2.50 m (8'2")	2.90 m (9'6")	2.50 m (8'2")	2.90 m (9'6")
H115 S	✓	✓	✓	✓	✓	✓	✓	✓
H120 S	✓	✓	✓	✓	✓	✓	✓	✓
H130 S	✓	✓	✓	✓	✓	✓*	✓	✓

Cat Pin Grabber Coupler

Undercarriage	Front and Rear Outriggers				Front Blade; Rear Outriggers			
Counterweight	3.5 mt		4.7 mt		3.5 mt		4.7 mt	
Boom Type	VA		VA		VA		VA	
Stick Length	2.50 m (8'2")	2.90 m (9'6")	2.50 m (8'2")	2.90 m (9'6")	2.50 m (8'2")	2.90 m (9'6")	2.50 m (8'2")	2.90 m (9'6")
H115 S	✓	✓	✓	✓	✓	✓	✓	✓
H120 S	✓	✓	✓	✓	✓	✓	✓	✓
H130 S	✓		✓		✓		✓	

(continued on next page)

Matching – Wheeled Excavators (continued)

Match
 Working Range Front Only
 Allowed Usage on Machine Less Than 50%
 No Match

M322 (continued)

Cat Pin Grabber Coupler (continued)

Undercarriage	Front Outriggers; Rear Blade				Rear Blade			
	3.5 mt		4.7 mt		3.5 mt		4.7 mt	
Counterweight	3.5 mt		4.7 mt		3.5 mt		4.7 mt	
Boom Type	VA		VA		VA		VA	
Stick Length	2.50 m (8'2")	2.90 m (9'6")	2.50 m (8'2")	2.90 m (9'6")	2.50 m (8'2")	2.90 m (9'6")	2.50 m (8'2")	2.90 m (9'6")
H115 S	✓	✓	✓	✓	✓	✓	✓	✓
H120 S	✓	✓	✓	✓	✓*		✓	✓
H130 S	✓		✓				✓	

CW-40 S Dedicated Coupler

Undercarriage	Front and Rear Outriggers				Front Blade; Rear Outriggers			
	3.5 mt		4.7 mt		3.5 mt		4.7 mt	
Counterweight	3.5 mt		4.7 mt		3.5 mt		4.7 mt	
Boom Type	VA		VA		VA		VA	
Stick Length	2.50 m (8'2")	2.90 m (9'6")	2.50 m (8'2")	2.90 m (9'6")	2.50 m (8'2")	2.90 m (9'6")	2.50 m (8'2")	2.90 m (9'6")
H115 S	✓	✓	✓	✓	✓	✓	✓	✓
H120 S	✓	✓	✓	✓	✓	✓	✓	✓
H130 S	✓		✓		✓		✓	

CW-40 S Dedicated Coupler (continued)

Undercarriage	Front Outriggers; Rear Blade				Rear Blade			
	3.5 mt		4.7 mt		3.5 mt		4.7 mt	
Counterweight	3.5 mt		4.7 mt		3.5 mt		4.7 mt	
Boom Type	VA		VA		VA		VA	
Stick Length	2.50 m (8'2")	2.90 m (9'6")	2.50 m (8'2")	2.90 m (9'6")	2.50 m (8'2")	2.90 m (9'6")	2.50 m (8'2")	2.90 m (9'6")
H115 S	✓	✓	✓	✓	✓	✓	✓	✓
H120 S	✓	✓	✓	✓	✓	✓	✓	✓
H130 S	✓		✓				✓	

CW-40 Dedicated Coupler

Undercarriage	Front and Rear Outriggers				Front Blade; Rear Outriggers			
	3.5 mt		4.7 mt		3.5 mt		4.7 mt	
Counterweight	3.5 mt		4.7 mt		3.5 mt		4.7 mt	
Boom Type	VA		VA		VA		VA	
Stick Length	2.50 m (8'2")	2.90 m (9'6")	2.50 m (8'2")	2.90 m (9'6")	2.50 m (8'2")	2.90 m (9'6")	2.50 m (8'2")	2.90 m (9'6")
H115 S	✓	✓	✓	✓	✓	✓	✓	✓
H120 S	✓	✓	✓	✓	✓	✓	✓	✓
H130 S	✓		✓		✓		✓	

CW-40 Dedicated Coupler (continued)

Undercarriage	Front Outriggers; Rear Blade				Rear Blade			
	3.5 mt		4.7 mt		3.5 mt		4.7 mt	
Counterweight	3.5 mt		4.7 mt		3.5 mt		4.7 mt	
Boom Type	VA		VA		VA		VA	
Stick Length	2.50 m (8'2")	2.90 m (9'6")	2.50 m (8'2")	2.90 m (9'6")	2.50 m (8'2")	2.90 m (9'6")	2.50 m (8'2")	2.90 m (9'6")
H115 S	✓	✓	✓	✓	✓	✓	✓	✓
H120 S	✓	✓	✓	✓	✓		✓	✓
H130 S	✓		✓				✓	

(continued on next page)

Hammer Technical Specifications

Matching – Wheeled Excavators *(continued)*

Match
 Working Range Front Only
 Allowed Usage on Machine Less Than 50%
 No Match

M322 *(continued)*

S70 Dedicated Coupler

Undercarriage	Front and Rear Outriggers				Front Blade; Rear Outriggers			
Counterweight	3.5 mt		4.7 mt		3.5 mt		4.7 mt	
Boom Type	VA		VA		VA		VA	
Stick Length	2.50 m (8'2")	2.90 m (9'6")	2.50 m (8'2")	2.90 m (9'6")	2.50 m (8'2")	2.90 m (9'6")	2.50 m (8'2")	2.90 m (9'6")
H115 S	✓	✓	✓	✓	✓	✓	✓	✓
H120 S	✓	✓	✓	✓	✓	✓	✓	✓
H130 S	✓		✓		✓		✓	

S70 Dedicated Coupler *(continued)*

Undercarriage	Front Outriggers; Rear Blade				Rear Blade			
Counterweight	3.5 mt		4.7 mt		3.5 mt		4.7 mt	
Boom Type	VA		VA		VA		VA	
Stick Length	2.50 m (8'2")	2.90 m (9'6")	2.50 m (8'2")	2.90 m (9'6")	2.50 m (8'2")	2.90 m (9'6")	2.50 m (8'2")	2.90 m (9'6")
H115 S	✓	✓	✓	✓	✓	✓	✓	✓
H120 S	✓	✓	✓	✓	✓		✓	✓
H130 S	✓		✓				✓	

HCS70 Dedicated Coupler

Undercarriage	Front and Rear Outriggers				Front Blade; Rear Outriggers			
Counterweight	3.5 mt		4.7 mt		3.5 mt		4.7 mt	
Boom Type	VA		VA		VA		VA	
Stick Length	2.50 m (8'2")	2.90 m (9'6")	2.50 m (8'2")	2.90 m (9'6")	2.50 m (8'2")	2.90 m (9'6")	2.50 m (8'2")	2.90 m (9'6")
H115 S	✓	✓	✓	✓	✓	✓	✓	✓
H120 S	✓	✓	✓	✓	✓	✓	✓	✓
H130 S	✓		✓		✓		✓	

HCS70 Dedicated Coupler *(continued)*

Undercarriage	Front Outriggers; Rear Blade				Rear Blade			
Counterweight	3.5 mt		4.7 mt		3.5 mt		4.7 mt	
Boom Type	VA		VA		VA		VA	
Stick Length	2.50 m (8'2")	2.90 m (9'6")	2.50 m (8'2")	2.90 m (9'6")	2.50 m (8'2")	2.90 m (9'6")	2.50 m (8'2")	2.90 m (9'6")
H115 S	✓	✓	✓	✓	✓	✓	✓	✓
H120 S	✓	✓	✓	✓	✓		✓	✓
H130 S	✓		✓				✓	

HCS70-55 Dedicated Coupler

Undercarriage	Front and Rear Outriggers			
Counterweight	3.5 mt		4.7 mt	
Boom Type	VA		VA	
Stick Length	2.50 m (8'2")	2.90 m (9'6")	2.50 m (8'2")	2.90 m (9'6")
H115 S	✓	✓	✓	✓
H120 S	✓	✓	✓	✓
H130 S				

(continued on next page)

Matching – Wheeled Excavators (continued)

Match
 Working Range Front Only
 Allowed Usage on Machine Less Than 50%
 No Match

M322 (continued)

HCS70-55 Dedicated Coupler (continued)

Undercarriage	Front Blade; Rear Outriggers							
Counterweight	3.5 mt		4.2 mt				4.7 mt	
Boom Type	VA		1 PC		VA		VA	
Stick Length	2.50 m (8'2")	2.90 m (9'6")	2.50 m (8'2")	2.90 m (9'6")	2.50 m (8'2")	2.90 m (9'6")	2.50 m (8'2")	2.90 m (9'6")
H115 S	✓	✓	✓	✓	✓	✓	✓	✓
H120 S	✓	✓	✓	✓	✓	✓	✓	✓
H130 S			✓	✓				

HCS70-55 Dedicated Coupler (continued)

Undercarriage	Front Outriggers; Rear Blade							
Counterweight	3.5 mt		4.2 mt				4.7 mt	
Boom Type	VA		1 PC		VA		VA	
Stick Length	2.50 m (8'2")	2.90 m (9'6")	2.50 m (8'2")	2.90 m (9'6")	2.50 m (8'2")	2.90 m (9'6")	2.50 m (8'2")	2.90 m (9'6")
H115 S	✓	✓	✓	✓	✓	✓	✓	✓
H120 S	✓	✓	✓	✓	✓	✓	✓	✓
H130 S			✓	✓				

HCS70-55 Dedicated Coupler (continued)

Undercarriage	MH (2.55 m)				MH (2.75 m)			
Counterweight	3.7 mt				4.2 mt			
Boom Type	1 PC		VA		1 PC		VA	
Stick Length	2.50 m (8'2")	2.90 m (9'6")	2.50 m (8'2")	2.90 m (9'6")	2.50 m (8'2")	2.90 m (9'6")	2.50 m (8'2")	2.90 m (9'6")
H115 S	✓	✓	✓	✓	✓	✓	✓	✓
H120 S	✓	✓	✓	✓	✓	✓	✓	✓
H130 S	✓	✓			✓	✓		

HCS70-55 Dedicated Coupler (continued)

Undercarriage	MH (2.99 m)				Rear Blade			
Counterweight	4.2 mt				3.5 mt			
Boom Type	1 PC		VA		VA		VA	
Stick Length	2.50 m (8'2")	2.90 m (9'6")	2.50 m (8'2")	2.90 m (9'6")	2.50 m (8'2")	2.90 m (9'6")	2.50 m (8'2")	2.90 m (9'6")
H115 S	✓	✓	✓	✓	✓	✓	✓	✓
H120 S	✓	✓	✓	✓	✓	✓	✓	✓
H130 S	✓	✓						

Tilt-Rotator TRS18 with CW30 S Dedicated Coupler

Undercarriage	Front and Rear Outriggers				Front Blade; Rear Outriggers			
Counterweight	3.5 mt		4.7 mt		3.5 mt		4.7 mt	
Boom Type	VA		VA		VA		VA	
Stick Length	2.50 m (8'2")	2.90 m (9'6")	2.50 m (8'2")	2.90 m (9'6")	2.50 m (8'2")	2.90 m (9'6")	2.50 m (8'2")	2.90 m (9'6")
H115 S	✓	✓	✓	✓	✓	✓	✓	✓

Tilt-Rotator TRS18 with CW30 S Dedicated Coupler (continued)

Undercarriage	Front Outriggers; Rear Blade				Rear Blade		
Counterweight	3.5 mt		4.7 mt		3.5 mt	4.7 mt	
Boom Type	VA		VA		VA	VA	
Stick Length	2.50 m (8'2")	2.90 m (9'6")	2.50 m (8'2")	2.90 m (9'6")	2.50 m (8'2")	2.50 m (8'2")	2.90 m (9'6")
H115 S	✓	✓	✓	✓	✓	✓	✓

(continued on next page)

Hammer Technical Specifications

Matching – Wheeled Excavators (continued)

Match
 Working Range Front Only
 Allowed Usage on Machine Less Than 50%
 No Match

M322 (continued)

CW30 S – Tilt-Rotator TRS18 – CW30 S

Undercarriage	Front and Rear Outriggers		Front Blade; Rear Outriggers		Front Outriggers; Rear Blade		Rear Blade
Counterweight	3.5 mt	4.7 mt	3.5 mt	4.7 mt	3.5 mt	4.7 mt	4.7 mt
Boom Type	VA	VA	VA	VA	VA	VA	VA
Stick Length	2.50 m (8'2")	2.50 m (8'2")	2.50 m (8'2")	2.50 m (8'2")	2.50 m (8'2")	2.50 m (8'2")	2.50 m (8'2")
H115 S	✓	✓	✓	✓	✓	✓	✓

Tilt-Rotator TRS18 with CW30 Dedicated Coupler

Undercarriage	Front and Rear Outriggers				Front Blade; Rear Outriggers			
Counterweight	3.5 mt		4.7 mt		3.5 mt		4.7 mt	
Boom Type	VA		VA		VA		VA	
Stick Length	2.50 m (8'2")	2.90 m (9'6")	2.50 m (8'2")	2.90 m (9'6")	2.50 m (8'2")	2.90 m (9'6")	2.50 m (8'2")	2.90 m (9'6")
H115 S	✓	✓	✓	✓	✓	✓	✓	✓

Tilt-Rotator TRS18 with CW30 Dedicated Coupler (continued)

Undercarriage	Front Outriggers; Rear Blade				Rear Blade			
Counterweight	3.5 mt		4.7 mt		3.5 mt		4.7 mt	
Boom Type	VA		VA		VA		VA	
Stick Length	2.50 m (8'2")	2.90 m (9'6")	2.50 m (8'2")	2.90 m (9'6")	2.50 m (8'2")	2.50 m (8'2")	2.90 m (9'6")	
H115 S	✓	✓	✓	✓	✓	✓	✓	

CW30 – Tilt-Rotator TRS18 – CW30

Undercarriage	Front and Rear Outriggers		Front Blade; Rear Outriggers		Front Outriggers; Rear Blade		Rear Blade
Counterweight	3.5 mt	4.7 mt	3.5 mt	4.7 mt	3.5 mt	4.7 mt	4.7 mt
Boom Type	VA	VA	VA	VA	VA	VA	VA
Stick Length	2.50 m (8'2")	2.50 m (8'2")	2.50 m (8'2")	2.50 m (8'2")	2.50 m (8'2")	2.50 m (8'2")	2.50 m (8'2")
H115 S	✓	✓	✓	✓	✓	✓	✓

Tilt-Rotator TRS18 with S70 Dedicated Coupler

Undercarriage	Front and Rear Outriggers				Front Blade; Rear Outriggers			
Counterweight	3.5 mt		4.7 mt		3.5 mt		4.7 mt	
Boom Type	VA		VA		VA		VA	
Stick Length	2.50 m (8'2")	2.90 m (9'6")	2.50 m (8'2")	2.90 m (9'6")	2.50 m (8'2")	2.90 m (9'6")	2.50 m (8'2")	2.90 m (9'6")
H115 S	✓	✓	✓	✓	✓	✓	✓	✓

Tilt-Rotator TRS18 with S70 Dedicated Coupler (continued)

Undercarriage	Front Outriggers; Rear Blade				Rear Blade			
Counterweight	3.5 mt		4.7 mt		3.5 mt		4.7 mt	
Boom Type	VA		VA		VA		VA	
Stick Length	2.50 m (8'2")	2.90 m (9'6")	2.50 m (8'2")	2.90 m (9'6")	2.50 m (8'2")	2.90 m (9'6")	2.50 m (8'2")	2.90 m (9'6")
H115 S	✓	✓	✓	✓	✓	✓	✓	✓

Tilt-Rotator TRS18 with HCS70 Dedicated Coupler

Undercarriage	Front and Rear Outriggers				Front Blade; Rear Outriggers			
Counterweight	3.5 mt		4.7 mt		3.5 mt		4.7 mt	
Boom Type	VA		VA		VA		VA	
Stick Length	2.50 m (8'2")	2.90 m (9'6")	2.50 m (8'2")	2.90 m (9'6")	2.50 m (8'2")	2.90 m (9'6")	2.50 m (8'2")	2.90 m (9'6")
H115 S	✓	✓	✓	✓	✓	✓	✓	✓

(continued on next page)

Matching – Wheeled Excavators *(continued)*

Match
 * Working Range Front Only
 † Allowed Usage on Machine Less Than 50%
 No Match

M322 *(continued)*

Tilt-Rotator TRS18 with HCS70 Dedicated Coupler *(continued)*

Undercarriage	Front Outriggers; Rear Blade				Rear Blade		
	3.5 mt		4.7 mt		3.5 mt	4.7 mt	
Counterweight	3.5 mt		4.7 mt		3.5 mt	4.7 mt	
Boom Type	VA		VA		VA	VA	
Stick Length	2.50 m (8'2")	2.90 m (9'6")	2.50 m (8'2")	2.90 m (9'6")	2.50 m (8'2")	2.50 m (8'2")	2.90 m (9'6")
H115 S	✓	✓	✓	✓	✓	✓	✓

Hammer Technical Specifications

Matching – Material Handlers

Match
 Working Range Front Only
 Allowed Usage on Machine Less Than 50%
 No Match

M322D2 MH

Cat Pin Grabber Coupler

Undercarriage	Front Outriggers; Rear Blade		MH (2 sets Outriggers)	
Counterweight	4.0 mt		4.0 mt	
Boom Type	1 PC		1 PC	
Stick Length	2.50 m (8'2")	2.80 m (9'2")	2.50 m (8'2")	2.80 m (9'2")
H115 S	✓	✓	✓	✓
H120 S	✓	✓	✓	✓
H130 S	✓		✓	

CW-30 S Dedicated Coupler

Undercarriage	Front Outriggers; Rear Blade		MH (2 sets Outriggers)	
Counterweight	4.0 mt		4.0 mt	
Boom Type	1 PC		1 PC	
Stick Length	2.50 m (8'2")	2.80 m (9'2")	2.50 m (8'2")	2.80 m (9'2")
H115 S	✓	✓	✓	✓
H120 S	✓	✓	✓	✓
H130 S		✓		✓

CW-30 Dedicated Coupler

Undercarriage	Front Outriggers; Rear Blade		MH (2 sets Outriggers)	
Counterweight	4.0 mt		4.0 mt	
Boom Type	1 PC		1 PC	
Stick Length	2.50 m (8'2")	2.80 m (9'2")	2.50 m (8'2")	2.80 m (9'2")
H115 S	✓	✓	✓	✓
H120 S	✓	✓	✓	✓
H130 S	✓		✓	

S70 – Tilt-Rotator TRS18 – S70

Undercarriage	Front and Rear Outriggers		Front Blade; Rear Outriggers		Front Outriggers; Rear Blade		Rear Blade
Counterweight	3.5 mt	4.7 mt	3.5 mt	4.7 mt	3.5 mt	4.7 mt	4.7 mt
Boom Type	VA	VA	VA	VA	VA	VA	VA
Stick Length	2.50 m (8'2")	2.50 m (8'2")	2.50 m (8'2")	2.50 m (8'2")	2.50 m (8'2")	2.50 m (8'2")	2.50 m (8'2")
H115 S	✓	✓	✓	✓	✓	✓	✓

Tilt-Rotator TRS18 with HCS70-55 Dedicated Coupler

Undercarriage	Front and Rear Outriggers		Front Blade; Rear Outriggers		Front Outriggers; Rear Blade		Rear Blade	
Counterweight	3.5 mt	4.7 mt	3.5 mt	4.7 mt	3.5 mt	4.7 mt	3.5 mt	4.7 mt
Boom Type	VA	VA	VA	VA	VA	VA	VA	VA
Stick Length	2.50 m (8'2")	2.50 m (8'2")	2.50 m (8'2")	2.50 m (8'2")	2.50 m (8'2")	2.50 m (8'2")	2.50 m (8'2")	2.50 m (8'2")
H115 S	✓	✓	✓	✓	✓	✓	✓	✓

M324D2 MH

Pin-on

Undercarriage	Front Outriggers; Rear Blade		MH (2 sets Outriggers)	
Counterweight	5.4 mt		5.4 mt	
Boom Type	1 PC		1 PC	
Stick Length	2.50 m (8'2")	2.90 m (9'6")	2.50 m (8'2")	2.90 m (9'6")
H115 S	✓	✓	✓	✓
H120 S	✓	✓	✓	✓
H130 S	✓		✓	

(continued on next page)

Matching – Material Handlers *(continued)*

Match
 * Working Range Front Only
 † Allowed Usage on Machine Less Than 50%
 No Match

M324D2 MH *(continued)*

Cat Pin Grabber Coupler

Undercarriage	Front Outriggers; Rear Blade		MH (2 sets Outriggers)	
Counterweight	5.4 mt		5.4 mt	
Boom Type	1 PC		1 PC	
Stick Length	2.50 m (8'2")	2.90 m (9'6")	2.50 m (8'2")	2.90 m (9'6")
H115 S	✓	✓	✓	✓
H120 S	✓	✓	✓	✓
H130 S	✓		✓	

CW-40 S Dedicated Coupler

Undercarriage	Front Outriggers; Rear Blade		MH (2 sets Outriggers)	
Counterweight	5.4 mt		5.4 mt	
Boom Type	1 PC		1 PC	
Stick Length	2.50 m (8'2")	2.90 m (9'6")	2.50 m (8'2")	2.90 m (9'6")
H115 S	✓	✓	✓	✓
H120 S	✓		✓	

CW-40 Dedicated Coupler

Undercarriage	Front Outriggers; Rear Blade		MH (2 sets Outriggers)	
Counterweight	5.4 mt		5.4 mt	
Boom Type	1 PC		1 PC	
Stick Length	2.50 m (8'2")	2.90 m (9'6")	2.50 m (8'2")	2.90 m (9'6")
H115 S	✓	✓	✓	✓
H120 S	✓		✓	

MH3022

Pin-on

Undercarriage	Front and Rear Outriggers							
Counterweight	3.7 mt				4.2 mt			
Boom Type	1 PC		VA		1 PC		VA	
Stick Length	2.50 m (8'2")	2.80 m (9'2")	2.50 m (8'2")	2.80 m (9'2")	2.50 m (8'2")	2.80 m (9'2")	2.50 m (8'2")	2.80 m (9'2")
H115 S	✓	✓	✓	✓	✓	✓	✓	✓
H120 S	✓	✓	✓	✓	✓	✓	✓	✓
H130 S	✓	✓	✓	✓	✓	✓	✓	✓

Pin-on *(continued)*

Undercarriage	Front Outriggers; Rear Blade							
Counterweight	3.7 mt				4.2 mt			
Boom Type	1 PC		VA		1 PC		VA	
Stick Length	2.50 m (8'2")	2.80 m (9'2")	2.50 m (8'2")	2.80 m (9'2")	2.50 m (8'2")	2.80 m (9'2")	2.50 m (8'2")	2.80 m (9'2")
H115 S	✓	✓	✓	✓	✓	✓	✓	✓
H120 S	✓	✓	✓	✓	✓	✓	✓	✓
H130 S	✓	✓	✓	✓	✓	✓	✓	✓

(continued on next page)

Hammer Technical Specifications

Matching – Material Handlers *(continued)*

Match
 * Working Range Front Only
 † Allowed Usage on Machine Less Than 50%
 No Match

MH3022 *(continued)*

Pin-on *(continued)*

Undercarriage	MH (2.55 m)							
Counterweight	3.7 mt				4.2 mt			
Boom Type	1 PC		VA		1 PC		VA	
Stick Length	2.50 m (8'2")	2.80 m (9'2")	2.50 m (8'2")	2.80 m (9'2")	2.50 m (8'2")	2.80 m (9'2")	2.50 m (8'2")	2.80 m (9'2")
H115 S	✓	✓	✓	✓	✓	✓	✓	✓
H120 S	✓	✓	✓	✓	✓	✓	✓	✓
H130 S	✓	✓	✓	✓	✓	✓	✓	✓

Pin-on *(continued)*

Undercarriage	MH (2.99 m)							
Counterweight	3.7 mt				4.2 mt			
Boom Type	1 PC		VA		1 PC		VA	
Stick Length	2.50 m (8'2")	2.80 m (9'2")	2.50 m (8'2")	2.80 m (9'2")	2.50 m (8'2")	2.80 m (9'2")	2.50 m (8'2")	2.80 m (9'2")
H115 S	✓	✓	✓	✓	✓	✓	✓	✓
H120 S	✓	✓	✓	✓	✓	✓	✓	✓
H130 S	✓	✓	✓	✓	✓	✓	✓	✓

Cat Pin Grabber Coupler

Undercarriage	Front and Rear Outriggers							
Counterweight	3.7 mt				4.2 mt			
Boom Type	1 PC		VA		1 PC		VA	
Stick Length	2.50 m (8'2")	2.80 m (9'2")	2.50 m (8'2")	2.80 m (9'2")	2.50 m (8'2")	2.80 m (9'2")	2.50 m (8'2")	2.80 m (9'2")
H115 S	✓	✓	✓	✓	✓	✓	✓	✓
H120 S	✓	✓	✓	✓	✓	✓	✓	✓
H130 S	✓	✓	✓		✓	✓	✓	

Cat Pin Grabber Coupler *(continued)*

Undercarriage	Front Outriggers; Rear Blade							
Counterweight	3.7 mt				4.2 mt			
Boom Type	1 PC		VA		1 PC		VA	
Stick Length	2.50 m (8'2")	2.80 m (9'2")	2.50 m (8'2")	2.80 m (9'2")	2.50 m (8'2")	2.80 m (9'2")	2.50 m (8'2")	2.80 m (9'2")
H115 S	✓	✓	✓	✓	✓	✓	✓	✓
H120 S	✓	✓	✓	✓	✓	✓	✓	✓
H130 S	✓	✓	✓		✓	✓	✓	

Cat Pin Grabber Coupler *(continued)*

Undercarriage	MH (2.55 m)					
Counterweight	3.7 mt					
Boom Type	1 PC			VA		
Stick Length	2.50 m (8'2")	2.80 m (9'2")	2.90 m (9'6")	2.50 m (8'2")	2.80 m (9'2")	2.90 m (9'6")
H115 S	✓	✓	✓	✓	✓	✓
H120 S	✓	✓	✓	✓	✓	✓
H130 S	✓		✓	✓		

(continued on next page)

Matching – Material Handlers *(continued)*

Match
 * Working Range Front Only
 † Allowed Usage on Machine Less Than 50%
 No Match

MH3022 *(continued)*

Cat Pin Grabber Coupler *(continued)*

Undercarriage	MH (2.55 m)			
Counterweight	4.2 mt			
Boom Type	1 PC		VA	
Stick Length	2.50 m (8'2")	2.80 m (9'2")	2.50 m (8'2")	2.80 m (9'2")
H115 S	✓	✓	✓	✓
H120 S	✓	✓	✓	✓
H130 S	✓		✓	

Cat Pin Grabber Coupler *(continued)*

Undercarriage	MH (2.99 m)							
Counterweight	3.7 mt				4.2 mt			
Boom Type	1 PC		VA		1 PC		VA	
Stick Length	2.50 m (8'2")	2.80 m (9'2")	2.50 m (8'2")	2.80 m (9'2")	2.50 m (8'2")	2.80 m (9'2")	2.50 m (8'2")	2.80 m (9'2")
H115 S	✓	✓	✓	✓	✓	✓	✓	✓
H120 S	✓	✓	✓	✓	✓	✓	✓	✓
H130 S	✓	✓	✓		✓	✓	✓	

CW-30 S Dedicated Coupler

Undercarriage	Front and Rear Outriggers							
Counterweight	3.7 mt				4.2 mt			
Boom Type	1 PC		VA		1 PC		VA	
Stick Length	2.50 m (8'2")	2.80 m (9'2")	2.50 m (8'2")	2.80 m (9'2")	2.50 m (8'2")	2.80 m (9'2")	2.50 m (8'2")	2.80 m (9'2")
H115 S	✓	✓	✓	✓	✓	✓	✓	✓
H120 S	✓	✓	✓	✓	✓	✓	✓	✓
H130 S	✓	✓	✓	✓	✓	✓	✓	✓

CW-30 S Dedicated Coupler *(continued)*

Undercarriage	Front Outriggers; Rear Blade							
Counterweight	3.7 mt				4.2 mt			
Boom Type	1 PC		VA		1 PC		VA	
Stick Length	2.50 m (8'2")	2.80 m (9'2")	2.50 m (8'2")	2.80 m (9'2")	2.50 m (8'2")	2.80 m (9'2")	2.50 m (8'2")	2.80 m (9'2")
H115 S	✓	✓	✓	✓	✓	✓	✓	✓
H120 S	✓	✓	✓	✓	✓	✓	✓	✓
H130 S	✓	✓	✓	✓	✓	✓	✓	✓

CW-30 S Dedicated Coupler *(continued)*

Undercarriage	MH (2.55 m)							
Counterweight	3.7 mt				4.2 mt			
Boom Type	1 PC		VA		1 PC		VA	
Stick Length	2.50 m (8'2")	2.80 m (9'2")	2.50 m (8'2")	2.80 m (9'2")	2.50 m (8'2")	2.80 m (9'2")	2.50 m (8'2")	2.80 m (9'2")
H115 S	✓	✓	✓	✓	✓	✓	✓	✓
H120 S	✓	✓	✓	✓	✓	✓	✓	✓
H130 S	✓	✓		✓	✓	✓		✓

(continued on next page)

Hammer Technical Specifications

Matching – Material Handlers *(continued)*

Match
 * Working Range Front Only
 † Allowed Usage on Machine Less Than 50%
 No Match

MH3022 *(continued)*

CW-30 S Dedicated Coupler *(continued)*

Undercarriage	MH (2.99 m)							
Counterweight	3.7 mt				4.2 mt			
Boom Type	1 PC		VA		1 PC		VA	
Stick Length	2.50 m (8'2")	2.80 m (9'2")	2.50 m (8'2")	2.80 m (9'2")	2.50 m (8'2")	2.80 m (9'2")	2.50 m (8'2")	2.80 m (9'2")
H115 S	✓	✓	✓	✓	✓	✓	✓	✓
H120 S	✓	✓	✓	✓	✓	✓	✓	✓
H130 S	✓	✓	✓	✓	✓	✓	✓	✓

CW-30 Dedicated Coupler

Undercarriage	Front and Rear Outriggers							
Counterweight	3.7 mt				4.2 mt			
Boom Type	1 PC		VA		1 PC		VA	
Stick Length	2.50 m (8'2")	2.80 m (9'2")	2.50 m (8'2")	2.80 m (9'2")	2.50 m (8'2")	2.80 m (9'2")	2.50 m (8'2")	2.80 m (9'2")
H115 S	✓	✓	✓	✓	✓	✓	✓	✓
H120 S	✓	✓	✓	✓	✓	✓	✓	✓
H130 S	✓	✓	✓	✓	✓	✓	✓	✓

CW-30 Dedicated Coupler *(continued)*

Undercarriage	Front Outriggers; Rear Blade							
Counterweight	3.7 mt				4.2 mt			
Boom Type	1 PC		VA		1 PC		VA	
Stick Length	2.50 m (8'2")	2.80 m (9'2")	2.50 m (8'2")	2.80 m (9'2")	2.50 m (8'2")	2.80 m (9'2")	2.50 m (8'2")	2.80 m (9'2")
H115 S	✓	✓	✓	✓	✓	✓	✓	✓
H120 S	✓	✓	✓	✓	✓	✓	✓	✓
H130 S	✓	✓	✓	✓	✓	✓	✓	✓

CW-30 Dedicated Coupler *(continued)*

Undercarriage	MH (2.55 m)							
Counterweight	3.7 mt				4.2 mt			
Boom Type	1 PC		VA		1 PC		VA	
Stick Length	2.50 m (8'2")	2.80 m (9'2")	2.50 m (8'2")	2.80 m (9'2")	2.50 m (8'2")	2.80 m (9'2")	2.50 m (8'2")	2.80 m (9'2")
H115 S	✓	✓	✓	✓	✓	✓	✓	✓
H120 S	✓	✓	✓	✓	✓	✓	✓	✓
H130 S	✓	✓	✓	✓	✓	✓	✓	✓

CW-30 Dedicated Coupler *(continued)*

Undercarriage	MH (2.99 m)							
Counterweight	3.7 mt				4.2 mt			
Boom Type	1 PC		VA		1 PC		VA	
Stick Length	2.50 m (8'2")	2.80 m (9'2")	2.50 m (8'2")	2.80 m (9'2")	2.50 m (8'2")	2.80 m (9'2")	2.50 m (8'2")	2.80 m (9'2")
H115 S	✓	✓	✓	✓	✓	✓	✓	✓
H120 S	✓	✓	✓	✓	✓	✓	✓	✓
H130 S	✓	✓	✓	✓	✓	✓	✓	✓

(continued on next page)

Matching – Material Handlers *(continued)*

Match
 * Working Range Front Only
 † Allowed Usage on Machine Less Than 50%
 No Match

MH3022 *(continued)*

CW-40 S Dedicated Coupler

Undercarriage	MH (2.55 m)			
Counterweight	3.7 mt			
Boom Type	1 PC		VA	
Stick Length	2.50 m (8'2")	2.90 m (9'6")	2.50 m (8'2")	2.90 m (9'6")
H115 S	✓	✓	✓	✓
H120 S	✓	✓	✓	✓
H130 S	✓	✓	✓	

CW-40 Dedicated Coupler

Undercarriage	MH (2.55 m)			
Counterweight	3.7 mt			
Boom Type	1 PC		VA	
Stick Length	2.50 m (8'2")	2.90 m (9'6")	2.50 m (8'2")	2.90 m (9'6")
H115 S	✓	✓	✓	✓
H120 S	✓	✓	✓	✓
H130 S	✓	✓	✓	

S70 Dedicated Coupler

Undercarriage	MH (2.55 m)			
Counterweight	3.7 mt			
Boom Type	1 PC		VA	
Stick Length	2.50 m (8'2")	2.90 m (9'6")	2.50 m (8'2")	2.90 m (9'6")
H115 S	✓	✓	✓	✓
H120 S	✓	✓	✓	✓
H130 S	✓	✓	✓	

HCS70 Dedicated Coupler

Undercarriage	MH (2.55 m)			
Counterweight	3.7 mt			
Boom Type	1 PC		VA	
Stick Length	2.50 m (8'2")	2.90 m (9'6")	2.50 m (8'2")	2.90 m (9'6")
H115 S	✓	✓	✓	✓
H120 S	✓	✓	✓	✓
H130 S	✓	✓	✓	

HCS70-55 Dedicated Coupler

Undercarriage	MH (2.55 m)			
Counterweight	3.7 mt			
Boom Type	1 PC		VA	
Stick Length	2.50 m (8'2")	2.90 m (9'6")	2.50 m (8'2")	2.90 m (9'6")
H115 S	✓	✓	✓	✓
H120 S	✓	✓	✓	✓
H130 S	✓	✓		

(continued on next page)

Hammer Technical Specifications

Matching – Material Handlers *(continued)*

Match
 * Working Range Front Only
 † Allowed Usage on Machine Less Than 50%
 No Match

MH3024

Pin-on

Undercarriage	Front and Rear Outriggers							
Counterweight	4.1 mt				5.2 mt			
Boom Type	1 PC		VA		1 PC		VA	
Stick Length	2.50 m (8'2")	2.90 m (9'6")	2.50 m (8'2")	2.90 m (9'6")	2.50 m (8'2")	2.90 m (9'6")	2.50 m (8'2")	2.90 m (9'6")
H115 S	✓	✓	✓	✓	✓	✓	✓	✓
H120 S	✓	✓	✓	✓	✓	✓	✓	✓
H130 S	✓	✓	✓	✓	✓	✓	✓	✓

Pin-on *(continued)*

Undercarriage	Front Outriggers; Rear Blade							
Counterweight	4.1 mt				5.2 mt			
Boom Type	1 PC		VA		1 PC		VA	
Stick Length	2.50 m (8'2")	2.90 m (9'6")	2.50 m (8'2")	2.90 m (9'6")	2.50 m (8'2")	2.90 m (9'6")	2.50 m (8'2")	2.90 m (9'6")
H115 S	✓	✓	✓	✓	✓	✓	✓	✓
H120 S	✓	✓	✓	✓	✓	✓	✓	✓
H130 S	✓	✓	✓	✓	✓	✓	✓	✓

Pin-on *(continued)*

Undercarriage	Front Blade; Rear Outriggers				Front Outriggers; Rear Blade			
Counterweight	4.2 mt							
Boom Type	1 PC		VA		1 PC		VA	
Stick Length	2.50 m (8'2")	2.80 m (9'2")	2.50 m (8'2")	2.80 m (9'2")	2.50 m (8'2")	2.80 m (9'2")	2.50 m (8'2")	2.80 m (9'2")
H115 S	✓	✓	✓	✓	✓	✓	✓	✓
H120 S	✓	✓	✓	✓	✓	✓	✓	✓
H130 S	✓	✓	✓	✓	✓	✓	✓	✓

Pin-on *(continued)*

Undercarriage	MH (2.75 m)				MH (2.99 m)			
Counterweight	4.2 mt							
Boom Type	1 PC		VA		1 PC		VA	
Stick Length	2.50 m (8'2")	2.80 m (9'2")	2.50 m (8'2")	2.80 m (9'2")	2.50 m (8'2")	2.90 m (9'6")	2.50 m (8'2")	2.90 m (9'6")
H115 S	✓	✓	✓	✓	✓	✓	✓	✓
H120 S	✓	✓	✓	✓	✓	✓	✓	✓
H130 S	✓	✓	✓	✓	✓	✓	✓	✓

Pin-on *(continued)*

Undercarriage	MH (2.99 m)							
Counterweight	4.2 mt				5.2 mt			
Boom Type	1 PC		VA		1 PC		VA	
Stick Length	2.50 m (8'2")	2.80 m (9'2")	2.50 m (8'2")	2.80 m (9'2")	2.50 m (8'2")	2.90 m (9'6")	2.50 m (8'2")	2.90 m (9'6")
H115 S	✓	✓	✓	✓	✓	✓	✓	✓
H120 S	✓	✓	✓	✓	✓	✓	✓	✓
H130 S	✓	✓	✓	✓	✓	✓	✓	✓

(continued on next page)

Matching – Material Handlers *(continued)*

Match
 * Working Range Front Only
 † Allowed Usage on Machine Less Than 50%
 No Match

MH3024 *(continued)*

Cat Pin Grabber Coupler

Undercarriage	Front and Rear Outriggers							
Counterweight	4.1 mt				5.2 mt			
Boom Type	1 PC		VA		1 PC		VA	
Stick Length	2.50 m (8'2")	2.90 m (9'6")	2.50 m (8'2")	2.90 m (9'6")	2.50 m (8'2")	2.90 m (9'6")	2.50 m (8'2")	2.90 m (9'6")
H115 S	✓	✓	✓	✓	✓	✓	✓	✓
H120 S	✓	✓	✓	✓	✓	✓	✓	✓
H130 S	✓		✓		✓		✓	

Cat Pin Grabber Coupler *(continued)*

Undercarriage	Front Blade; Rear Outriggers					
Counterweight	4.2 mt					
Boom Type	1 PC			VA		
Stick Length	2.50 m (8'2")	2.80 m (9'2")	2.90 m (9'6")	2.50 m (8'2")	2.80 m (9'2")	2.90 m (9'6")
H115 S	✓	✓	✓	✓	✓	✓
H120 S	✓	✓	✓	✓	✓	✓
H130 S	✓		✓	✓		

Cat Pin Grabber Coupler *(continued)*

Undercarriage	Front Outriggers; Rear Blade			
Counterweight	4.1 mt			
Boom Type	1 PC		VA	
Stick Length	2.50 m (8'2")	2.90 m (9'6")	2.50 m (8'2")	2.90 m (9'6")
H115 S	✓	✓	✓	✓
H120 S	✓	✓	✓	✓
H130 S	✓		✓	

Cat Pin Grabber Coupler *(continued)*

Undercarriage	Front Outriggers; Rear Blade					
Counterweight	4.2 mt					
Boom Type	1 PC			VA		
Stick Length	2.50 m (8'2")	2.80 m (9'2")	2.90 m (9'6")	2.50 m (8'2")	2.80 m (9'2")	2.90 m (9'6")
H115 S	✓	✓	✓	✓	✓	✓
H120 S	✓	✓	✓	✓	✓	✓
H130 S	✓		✓	✓		

Cat Pin Grabber Coupler *(continued)*

Undercarriage	Front Outriggers; Rear Blade			
Counterweight	5.2 mt			
Boom Type	1 PC		VA	
Stick Length	2.50 m (8'2")	2.90 m (9'6")	2.50 m (8'2")	2.90 m (9'6")
H115 S	✓	✓	✓	✓
H120 S	✓	✓	✓	✓
H130 S	✓		✓	

(continued on next page)

Hammer Technical Specifications

Matching – Material Handlers *(continued)*

Match
 Working Range Front Only
 Allowed Usage on Machine Less Than 50%
 No Match

MH3024 *(continued)*

Cat Pin Grabber Coupler *(continued)*

Undercarriage	MH (2.75 m)					
Counterweight	4.2 mt					
Boom Type	1 PC			VA		
Stick Length	2.50 m (8'2")	2.80 m (9'2")	2.90 m (9'6")	2.50 m (8'2")	2.80 m (9'2")	2.90 m (9'6")
H115 S	✓	✓	✓	✓	✓	✓
H120 S	✓	✓	✓	✓	✓	✓
H130 S	✓		✓	✓		

Cat Pin Grabber Coupler *(continued)*

Undercarriage	MH (2.99 m)			
Counterweight	4.1 mt			
Boom Type	1 PC		VA	
Stick Length	2.50 m (8'2")	2.90 m (9'6")	2.50 m (8'2")	2.90 m (9'6")
H115 S	✓	✓	✓	✓
H120 S	✓	✓	✓	✓
H130 S	✓		✓	

Cat Pin Grabber Coupler *(continued)*

Undercarriage	MH (2.99 m)					
Counterweight	4.2 mt					
Boom Type	1 PC			VA		
Stick Length	2.50 m (8'2")	2.80 m (9'2")	2.90 m (9'6")	2.50 m (8'2")	2.80 m (9'2")	2.90 m (9'6")
H115 S	✓	✓	✓	✓	✓	✓
H120 S	✓	✓	✓	✓	✓	✓
H130 S	✓		✓	✓		

Cat Pin Grabber Coupler *(continued)*

Undercarriage	MH (2.99 m)			
Counterweight	5.2 mt			
Boom Type	1 PC		VA	
Stick Length	2.50 m (8'2")	2.90 m (9'6")	2.50 m (8'2")	2.90 m (9'6")
H115 S	✓	✓	✓	✓
H120 S	✓	✓	✓	✓
H130 S	✓		✓	

CW-30 S Dedicated Coupler

Undercarriage	Front Blade; Rear Outriggers				Front Outriggers; Rear Blade			
Counterweight	4.2 mt				4.2 mt			
Boom Type	1 PC		VA		1 PC		VA	
Stick Length	2.50 m (8'2")	2.80 m (9'2")	2.50 m (8'2")	2.80 m (9'2")	2.50 m (8'2")	2.80 m (9'2")	2.50 m (8'2")	2.80 m (9'2")
H115 S	✓	✓	✓	✓	✓	✓	✓	✓
H120 S	✓	✓	✓	✓	✓	✓	✓	✓
H130 S	✓	✓		✓	✓	✓		✓

(continued on next page)

Matching – Material Handlers *(continued)*

Match
 * Working Range Front Only
 † Allowed Usage on Machine Less Than 50%
 No Match

MH3024 *(continued)*

CW-30 S Dedicated Coupler *(continued)*

Undercarriage	MH (2.75 m)				MH (2.99 m)			
Counterweight	4.2 mt				4.2 mt			
Boom Type	1 PC		VA		1 PC		VA	
Stick Length	2.50 m (8'2")	2.80 m (9'2")	2.50 m (8'2")	2.80 m (9'2")	2.50 m (8'2")	2.80 m (9'2")	2.50 m (8'2")	2.80 m (9'2")
H115 S	✓	✓	✓	✓	✓	✓	✓	✓
H120 S	✓	✓	✓	✓	✓	✓	✓	✓
H130 S	✓	✓	✓	✓	✓	✓	✓	✓

CW-30 Dedicated Coupler

Undercarriage	Front Blade; Rear Outriggers				Front Outriggers; Rear Blade			
Counterweight	4.2 mt				4.2 mt			
Boom Type	1 PC		VA		1 PC		VA	
Stick Length	2.50 m (8'2")	2.80 m (9'2")	2.50 m (8'2")	2.80 m (9'2")	2.50 m (8'2")	2.80 m (9'2")	2.50 m (8'2")	2.80 m (9'2")
H115 S	✓	✓	✓	✓	✓	✓	✓	✓
H120 S	✓	✓	✓	✓	✓	✓	✓	✓
H130 S	✓	✓	✓	✓	✓	✓	✓	✓

CW-30 Dedicated Coupler *(continued)*

Undercarriage	MH (2.75 m)				MH (2.99 m)			
Counterweight	4.2 mt				4.2 mt			
Boom Type	1 PC		VA		1 PC		VA	
Stick Length	2.50 m (8'2")	2.80 m (9'2")	2.50 m (8'2")	2.80 m (9'2")	2.50 m (8'2")	2.80 m (9'2")	2.50 m (8'2")	2.80 m (9'2")
H115 S	✓	✓	✓	✓	✓	✓	✓	✓
H120 S	✓	✓	✓	✓	✓	✓	✓	✓
H130 S	✓	✓	✓	✓	✓	✓	✓	✓

CW-40 S Dedicated Coupler

Undercarriage	Front and Rear Outriggers							
Counterweight	4.1 mt				5.2 mt			
Boom Type	1 PC		VA		1 PC		VA	
Stick Length	2.50 m (8'2")	2.90 m (9'6")	2.50 m (8'2")	2.90 m (9'6")	2.50 m (8'2")	2.90 m (9'6")	2.50 m (8'2")	2.90 m (9'6")
H115 S	✓	✓	✓	✓	✓	✓	✓	✓
H120 S	✓	✓	✓	✓	✓	✓	✓	✓
H130 S	✓	✓	✓	✓	✓	✓	✓	✓

CW-40 S Dedicated Coupler *(continued)*

Undercarriage	Front Blade; Rear Outriggers				Front Outriggers; Rear Blade			
Counterweight	4.2 mt				4.1 mt			
Boom Type	1 PC		VA		1 PC		VA	
Stick Length	2.50 m (8'2")	2.90 m (9'6")	2.50 m (8'2")	2.90 m (9'6")	2.50 m (8'2")	2.90 m (9'6")	2.50 m (8'2")	2.90 m (9'6")
H115 S	✓	✓	✓	✓	✓	✓	✓	✓
H120 S	✓	✓	✓	✓	✓	✓	✓	✓
H130 S	✓	✓	✓	✓	✓	✓	✓	✓

(continued on next page)

Hammer Technical Specifications

Matching – Material Handlers *(continued)*

Match
 * Working Range Front Only
 † Allowed Usage on Machine Less Than 50%
 No Match

MH3024 *(continued)*

CW-40 S Dedicated Coupler *(continued)*

Undercarriage	Front Outriggers; Rear Blade							
Counterweight	4.2 mt				5.2 mt			
Boom Type	1 PC		VA		1 PC		VA	
Stick Length	2.50 m (8'2")	2.90 m (9'6")	2.50 m (8'2")	2.90 m (9'6")	2.50 m (8'2")	2.90 m (9'6")	2.50 m (8'2")	2.90 m (9'6")
H115 S	✓	✓	✓	✓	✓	✓	✓	✓
H120 S	✓	✓	✓	✓	✓	✓	✓	✓
H130 S	✓	✓	✓		✓	✓	✓	

CW-40 S Dedicated Coupler *(continued)*

Undercarriage	MH (2.75 m)				MH (2.99 m)			
Counterweight	4.2 mt				4.1 mt			
Boom Type	1 PC		VA		1 PC		VA	
Stick Length	2.50 m (8'2")	2.90 m (9'6")	2.50 m (8'2")	2.90 m (9'6")	2.50 m (8'2")	2.90 m (9'6")	2.50 m (8'2")	2.90 m (9'6")
H115 S	✓	✓	✓	✓	✓	✓	✓	✓
H120 S	✓	✓	✓	✓	✓	✓	✓	✓
H130 S	✓	✓	✓		✓	✓	✓	

CW-40 S Dedicated Coupler *(continued)*

Undercarriage	MH (2.99 m)							
Counterweight	4.2 mt				5.2 mt			
Boom Type	1 PC		VA		1 PC		VA	
Stick Length	2.50 m (8'2")	2.90 m (9'6")	2.50 m (8'2")	2.90 m (9'6")	2.50 m (8'2")	2.90 m (9'6")	2.50 m (8'2")	2.90 m (9'6")
H115 S	✓	✓	✓	✓	✓	✓	✓	✓
H120 S	✓	✓	✓	✓	✓	✓	✓	✓
H130 S	✓	✓	✓		✓	✓	✓	

CW-40 Dedicated Coupler

Undercarriage	Front and Rear Outriggers							
Counterweight	4.1 mt				5.2 mt			
Boom Type	1 PC		VA		1 PC		VA	
Stick Length	2.50 m (8'2")	2.90 m (9'6")	2.50 m (8'2")	2.90 m (9'6")	2.50 m (8'2")	2.90 m (9'6")	2.50 m (8'2")	2.90 m (9'6")
H115 S	✓	✓	✓	✓	✓	✓	✓	✓
H120 S	✓	✓	✓	✓	✓	✓	✓	✓
H130 S	✓	✓	✓		✓	✓	✓	

CW-40 Dedicated Coupler *(continued)*

Undercarriage	Front Blade; Rear Outriggers				Front Outriggers; Rear Blade			
Counterweight	4.2 mt				4.1 mt			
Boom Type	1 PC		VA		1 PC		VA	
Stick Length	2.50 m (8'2")	2.90 m (9'6")	2.50 m (8'2")	2.90 m (9'6")	2.50 m (8'2")	2.90 m (9'6")	2.50 m (8'2")	2.90 m (9'6")
H115 S	✓	✓	✓	✓	✓	✓	✓	✓
H120 S	✓	✓	✓	✓	✓	✓	✓	✓
H130 S	✓	✓	✓		✓	✓	✓	

(continued on next page)

Matching – Material Handlers (continued)

Match
 * Working Range Front Only
 † Allowed Usage on Machine Less Than 50%
 No Match

MH3024 (continued)

CW-40 Dedicated Coupler (continued)

Undercarriage	Front Outriggers; Rear Blade							
Counterweight	4.2 mt				5.2 mt			
Boom Type	1 PC		VA		1 PC		VA	
Stick Length	2.50 m (8'2")	2.90 m (9'6")	2.50 m (8'2")	2.90 m (9'6")	2.50 m (8'2")	2.90 m (9'6")	2.50 m (8'2")	2.90 m (9'6")
H115 S	✓	✓	✓	✓	✓	✓	✓	✓
H120 S	✓	✓	✓	✓	✓	✓	✓	✓
H130 S	✓	✓	✓		✓	✓	✓	

CW-40 Dedicated Coupler (continued)

Undercarriage	MH (2.75 m)				MH (2.99 m)			
Counterweight	4.2 mt				4.1 mt			
Boom Type	1 PC		VA		1 PC		VA	
Stick Length	2.50 m (8'2")	2.90 m (9'6")	2.50 m (8'2")	2.90 m (9'6")	2.50 m (8'2")	2.90 m (9'6")	2.50 m (8'2")	2.90 m (9'6")
H115 S	✓	✓	✓	✓	✓	✓	✓	✓
H120 S	✓	✓	✓	✓	✓	✓	✓	✓
H130 S	✓	✓	✓		✓	✓	✓	

CW-40 Dedicated Coupler (continued)

Undercarriage	MH (2.99 m)							
Counterweight	4.2 mt				5.2 mt			
Boom Type	1 PC		VA		1 PC		VA	
Stick Length	2.50 m (8'2")	2.90 m (9'6")	2.50 m (8'2")	2.90 m (9'6")	2.50 m (8'2")	2.90 m (9'6")	2.50 m (8'2")	2.90 m (9'6")
H115 S	✓	✓	✓	✓	✓	✓	✓	✓
H120 S	✓	✓	✓	✓	✓	✓	✓	✓
H130 S	✓	✓	✓		✓	✓	✓	

S70 Dedicated Coupler

Undercarriage	Front Blade; Rear Outriggers				Front Outriggers; Rear Blade			
Counterweight	4.2 mt				4.2 mt			
Boom Type	1 PC		VA		1 PC		VA	
Stick Length	2.50 m (8'2")	2.90 m (9'6")	2.50 m (8'2")	2.90 m (9'6")	2.50 m (8'2")	2.90 m (9'6")	2.50 m (8'2")	2.90 m (9'6")
H115 S	✓	✓	✓	✓	✓	✓	✓	✓
H120 S	✓	✓	✓	✓	✓	✓	✓	✓
H130 S	✓	✓	✓		✓	✓	✓	

S70 Dedicated Coupler (continued)

Undercarriage	MH (2.75 m)				MH (2.99 m)			
Counterweight	4.2 mt				4.2 mt			
Boom Type	1 PC		VA		1 PC		VA	
Stick Length	2.50 m (8'2")	2.90 m (9'6")	2.50 m (8'2")	2.90 m (9'6")	2.50 m (8'2")	2.90 m (9'6")	2.50 m (8'2")	2.90 m (9'6")
H115 S	✓	✓	✓	✓	✓	✓	✓	✓
H120 S	✓	✓	✓	✓	✓	✓	✓	✓
H130 S	✓	✓	✓		✓	✓	✓	

(continued on next page)

Hammer Technical Specifications

Matching – Material Handlers *(continued)*

Match
 * Working Range Front Only
 † Allowed Usage on Machine Less Than 50%
 No Match

MH3026

Pin-on

Undercarriage	Front Blade; Rear Outriggers				Front Outriggers; Rear Blade			
Counterweight	5.2 mt				5.2 mt			
Boom Type	1 PC		VA		1 PC		VA	
Stick Length	2.50 m (8'2")	2.90 m (9'6")	2.50 m (8'2")	2.90 m (9'6")	2.50 m (8'2")	2.90 m (9'6")	2.50 m (8'2")	2.90 m (9'6")
H115 S	✓	✓	✓	✓	✓	✓	✓	✓
H120 S	✓	✓	✓	✓	✓	✓	✓	✓
H130 S	✓	✓	✓	✓	✓	✓	✓	✓

Pin-on *(continued)*

Undercarriage	MH (2.75 m)				MH (2.99 m)			
Counterweight	5.2 mt				5.2 mt			
Boom Type	1 PC		VA		1 PC		VA	
Stick Length	2.50 m (8'2")	2.90 m (9'6")	2.50 m (8'2")	2.90 m (9'6")	2.50 m (8'2")	2.90 m (9'6")	2.50 m (8'2")	2.90 m (9'6")
H115 S	✓	✓	✓	✓	✓	✓	✓	✓
H120 S	✓	✓	✓	✓	✓	✓	✓	✓
H130 S	✓	✓	✓	✓	✓	✓	✓	✓

Cat Pin Grabber Coupler

Undercarriage	Front Blade; Rear Outriggers				Front Outriggers; Rear Blade			
Counterweight	5.2 mt				5.2 mt			
Boom Type	1 PC		VA		1 PC		VA	
Stick Length	2.50 m (8'2")	2.90 m (9'6")	2.50 m (8'2")	2.90 m (9'6")	2.50 m (8'2")	2.90 m (9'6")	2.50 m (8'2")	2.90 m (9'6")
H115 S	✓	✓	✓	✓	✓	✓	✓	✓
H120 S	✓	✓	✓	✓	✓	✓	✓	✓
H130 S	✓		✓		✓		✓	

Cat Pin Grabber Coupler *(continued)*

Undercarriage	MH (2.75 m)				MH (2.99 m)			
Counterweight	5.2 mt				5.2 mt			
Boom Type	1 PC		VA		1 PC		VA	
Stick Length	2.50 m (8'2")	2.90 m (9'6")	2.50 m (8'2")	2.90 m (9'6")	2.50 m (8'2")	2.90 m (9'6")	2.50 m (8'2")	2.90 m (9'6")
H115 S	✓	✓	✓	✓	✓	✓	✓	✓
H120 S	✓	✓	✓	✓	✓	✓	✓	✓
H130 S	✓		✓		✓		✓	

CW-40 S Dedicated Coupler

Undercarriage	Front Blade; Rear Outriggers				Front Outriggers; Rear Blade			
Counterweight	5.2 mt				5.2 mt			
Boom Type	1 PC		VA		1 PC		VA	
Stick Length	2.50 m (8'2")	2.90 m (9'6")	2.50 m (8'2")	2.90 m (9'6")	2.50 m (8'2")	2.90 m (9'6")	2.50 m (8'2")	2.90 m (9'6")
H115 S	✓	✓	✓	✓	✓	✓	✓	✓
H120 S	✓	✓	✓	✓	✓	✓	✓	✓
H130 S	✓		✓		✓		✓	

(continued on next page)

Matching – Material Handlers *(continued)*

Match
 * Working Range Front Only
 † Allowed Usage on Machine Less Than 50%
 No Match

MH3026 *(continued)*

CW-40 S Dedicated Coupler *(continued)*

Undercarriage	MH (2.75 m)				MH (2.99 m)			
Counterweight	5.2 mt				5.2 mt			
Boom Type	1 PC		VA		1 PC		VA	
Stick Length	2.50 m (8'2")	2.90 m (9'6")	2.50 m (8'2")	2.90 m (9'6")	2.50 m (8'2")	2.90 m (9'6")	2.50 m (8'2")	2.90 m (9'6")
H115 S	✓	✓	✓	✓	✓	✓	✓	✓
H120 S	✓	✓	✓	✓	✓	✓	✓	✓
H130 S	✓		✓		✓		✓	

CW-40 Dedicated Coupler

Undercarriage	Front Blade; Rear Outriggers				Front Outriggers; Rear Blade			
Counterweight	5.2 mt				5.2 mt			
Boom Type	1 PC		VA		1 PC		VA	
Stick Length	2.50 m (8'2")	2.90 m (9'6")	2.50 m (8'2")	2.90 m (9'6")	2.50 m (8'2")	2.90 m (9'6")	2.50 m (8'2")	2.90 m (9'6")
H115 S	✓	✓	✓	✓	✓	✓	✓	✓
H120 S	✓	✓	✓	✓	✓	✓	✓	✓
H130 S	✓		✓		✓		✓	

CW-40 Dedicated Coupler *(continued)*

Undercarriage	MH (2.75 m)				MH (2.99 m)			
Counterweight	5.2 mt				5.2 mt			
Boom Type	1 PC		VA		1 PC		VA	
Stick Length	2.50 m (8'2")	2.90 m (9'6")	2.50 m (8'2")	2.90 m (9'6")	2.50 m (8'2")	2.90 m (9'6")	2.50 m (8'2")	2.90 m (9'6")
H115 S	✓	✓	✓	✓	✓	✓	✓	✓
H120 S	✓	✓	✓	✓	✓	✓	✓	✓
H130 S	✓		✓		✓		✓	

HCS70 Dedicated Coupler

Undercarriage	Front Blade; Rear Outriggers				Front Outriggers; Rear Blade			
Counterweight	4.2 mt				4.2 mt			
Boom Type	1 PC		VA		1 PC		VA	
Stick Length	2.50 m (8'2")	2.90 m (9'6")	2.50 m (8'2")	2.90 m (9'6")	2.50 m (8'2")	2.90 m (9'6")	2.50 m (8'2")	2.90 m (9'6")
H115 S	✓	✓	✓	✓	✓	✓	✓	✓
H120 S	✓	✓	✓	✓	✓	✓	✓	✓
H130 S	✓	✓	✓		✓	✓	✓	

HCS70 Dedicated Coupler *(continued)*

Undercarriage	MH (2.75 m)				MH (2.99 m)			
Counterweight	4.2 mt				4.2 mt			
Boom Type	1 PC		VA		1 PC		VA	
Stick Length	2.50 m (8'2")	2.90 m (9'6")	2.50 m (8'2")	2.90 m (9'6")	2.50 m (8'2")	2.90 m (9'6")	2.50 m (8'2")	2.90 m (9'6")
H115 S	✓	✓	✓	✓	✓	✓	✓	✓
H120 S	✓	✓	✓	✓	✓	✓	✓	✓
H130 S	✓	✓	✓		✓	✓	✓	

(continued on next page)

Hammer Technical Specifications

Matching – Material Handlers *(continued)*

Match
 * Working Range Front Only
 † Allowed Usage on Machine Less Than 50%
 No Match

MH3026 *(continued)*

HCS70-55 Dedicated Coupler

Undercarriage	Front Blade; Rear Outriggers				Front Outriggers; Rear Blade			
Counterweight	4.2 mt				4.2 mt			
Boom Type	1 PC		VA		1 PC		VA	
Stick Length	2.50 m (8'2")	2.90 m (9'6")	2.50 m (8'2")	2.90 m (9'6")	2.50 m (8'2")	2.90 m (9'6")	2.50 m (8'2")	2.90 m (9'6")
H115 S	✓	✓	✓	✓	✓	✓	✓	✓
H120 S	✓	✓	✓	✓	✓	✓	✓	✓
H130 S	✓	✓			✓	✓		

HCS70-55 Dedicated Coupler *(continued)*

Undercarriage	MH (2.75 m)				MH (2.99 m)			
Counterweight	4.2 mt				4.2 mt			
Boom Type	1 PC		VA		1 PC		VA	
Stick Length	2.50 m (8'2")	2.90 m (9'6")	2.50 m (8'2")	2.90 m (9'6")	2.50 m (8'2")	2.90 m (9'6")	2.50 m (8'2")	2.90 m (9'6")
H115 S	✓	✓	✓	✓	✓	✓	✓	✓
H120 S	✓	✓	✓	✓	✓	✓	✓	✓
H130 S	✓	✓			✓	✓		

Additional Options

Model	Part No.	Rock Edges	Wear Package (factory-installed)	Wear Package, Dealer-install	Autolube Kit, Hammer-mount	Autolube Kit, Carrier-mount
H110 S Top-mount	355-3817	355-5839	No	367-0863	317-4203	152-3395
	385-0326	355-5839	No	367-0863	317-4203	152-3395
H115 S Top-mount	355-7065	355-5839	No	367-0863	317-4203	152-3395
	385-0328	355-5839	No	367-0863	317-4203	152-3395
H120 S Top-mount	355-7061	355-5785	No	365-9541	317-4204	152-3395
	385-0329	355-5785	No	365-9541	317-4204	152-3395
H130 S Top-mount	355-7063	355-5785	No	365-9541	317-4204	152-3395
	385-0330	355-5785	No	365-9541	317-4204	152-3395
H140 S Top-mount	363-0738	369-9027	No	388-3071	317-4204	152-3395
	426-4892	369-9027	Yes	388-3071	317-4204	152-3395
	431-0575	369-9027	No	388-3071	317-4204	152-3395
	431-0581	369-9027	No	388-3071	317-4204	152-3395
H160 S Top-mount	366-5119	371-7113	No	388-3071	317-4206	152-3395
	426-4894	371-7113	Yes	388-3071	317-4206	152-3395
	431-0578	371-7113	No	388-3071	317-4206	152-3395
	431-0584	371-7113	No	388-3071	317-4206	152-3395
H180 S Top-mount	366-5168	371-7113	No	388-3071	317-4206	152-3395
	426-4896	371-7113	Yes	388-3071	317-4206	152-3395
	431-0580	371-7113	No	388-3071	317-4206	152-3395
	431-0589	371-7113	No	388-3071	317-4206	152-3395
H190 S Top-mount					Included	
H215 S Top mount					Included	

Hammer Technical Specifications

Autolube

Autolube Kit, hammer-mount	Part No.	317-4203	317-4204	317-4206
Supply Pressure minimum, hammer circuit	bar	90	90	90
	psi	1305	1305	1305
Supply Pressure maximum, hammer circuit	bar	250	250	250
	psi	3626	3626	3626
Flow Displacement, per minute	l	2	2	2
	gal	0.6	0.6	0.6
Operating Temperature, minimum	°C	0	0	0
	°F	31	31	31
Operating Temperature, maximum	°C	70	70	70
	°F	158	158	158
Grease Flow, factory default, per minute	cc	1.68	1.68	1.68
	in ³	0.11	0.11	0.11
Autolube, hammer-mount, grease	single	317-8491	317-8491	317-8491
	12-pack	317-8492	317-8492	317-8492
Autolube Kit, carrier-mount				152-3395
Autolube, carrier-mount, hammer paste, cartridge (400 g)				130-6951
Autolube, carrier-mount, hammer paste, pail (5 kg)				133-8807

For more complete information on Cat products, dealer services, and industry solutions, visit us on the web at www.cat.com

GEJQ0398 (01-2022)
(AUZ, HR, EU, S Am, N Am)

© 2022 Caterpillar
All rights reserved

Materials and specifications are subject to change without notice. Featured machines in photos may include additional equipment. See your Cat dealer for available options.

CAT, CATERPILLAR, LET'S DO THE WORK, their respective logos, "Caterpillar Corporate Yellow," the "Power Edge" and Cat "Modern Hex" trade dress as well as corporate and product identity used herein, are trademarks of Caterpillar and may not be used without permission.

