



Image shown may not reflect actual configuration.

## Features and Benefits

### Robust/Highly Corrosion-Resistant Construction

- Combined hot water and power generation
- Weather proof Caterpillar white enclosure
- Zinc plated or stainless steel fasteners
- 22-gauge galvanized steel construction
- Pitched roof for improved rain ingress protection
- Internally mounted overhead crane w/ trolley for easy maintenance
- Externally mounted exhaust system (muffler and heat exchanger)
- 75 dBA enclosure at 7 m
- Vibration spring isolators
- Roof mounted cooling system
- 120 MPH wind load
- Motorized dampers
- Integrated crankcase ventilation system (CCV)
- Integrated gas fuel train NFPA37 & CSAB149.3 with external fuel connections
- Oil makeup tank (50 gallon), Waste oil tank (300 gal / 2 oil changes), Fresh oil tank (500 gal / 2 oil changes + makeup)
- Interior AC lighting system and receptacles
- Optional: Cold-weather bundle including enclosure heaters and ventilation recirculation
- Optional: Oxidation catalyst

### Controls

- Cat® Switchgear master control panel
  - 19" color touchscreen
  - EMCP 4.3 genset controller
  - Multi-function protective relay
  - 15kV generator breaker
  - Synchronization and utility paralleling control
  - Balance of Plant and CHP controller
- Modbus TCP interface for customer SCADA
- Cat Connect Enabled
- Requires customer provided 480V, 3ph, 150A shore power

## Combined Heat and Power Enclosure with G3516H Generator Set

The sound attenuated, factory installed enclosure is designed for safety and combined heat and power optimization. Rugged construction provides weather protection and the ability to withstand exposure to the elements.

### Security and Safety

- Lockable access doors with standard key use
- Separate electrical control room
- Cooling fan and battery charging alternator fully guarded
- Oil fill and battery access inside enclosure only
- Externally mounted emergency stop button
- Designed for spreader-bar lifting to ensure safety
- Gas leak alarm
- Fire detection system
- Spill containment floor
- Four E-stop buttons at convenient locations
- Emergency lighting
- Optional: Fire suppression system
- Optional: Interior DC lighting system with automatic shutoff timer

### Excellent Access

- Walk-in enclosure allows sufficient access for operators and technicians
- Cable stub up is easily accessible through the floor and wall access panel
- Double doors on both sides
- Batteries recessed in base to improve maintenance access to the engine

### Certifications

- NSPS Factory Compliant
- UL2200 Compliant
- CSA / TSSA
- Tested and analyzed in accordance with ASCE 7

		100% Gross Power	75% Gross Power	50% Gross Power
POWER	Ambient Temperature (°F)	77	77	77
	CHP Fuel Input (MMBtu per hour LHV)	16.5	12.6	8.9
	Gross Engine Output (bkW)	2077	1558	1045
	Net Electricity Output (ekW)	1982	1486	991
	Net Electric Efficiency % (LHV)	42.9	41.9	39.8
HOT WATER	Supply Temperature to Site (°F)	210		
	HW flow (GPM)	273		
	Return Temperature from Site (°F)	158		
	Hot Water Capacity (MMBtu/hr)	7.1		
	Thermal Efficiency % (LHV)	43		
	CHP Fuel Use Eff % (Hot Water Operation)	85.9		

Notes

- 1) Taken from EM2364-00
- 2) Calculated using ISO 3046/1

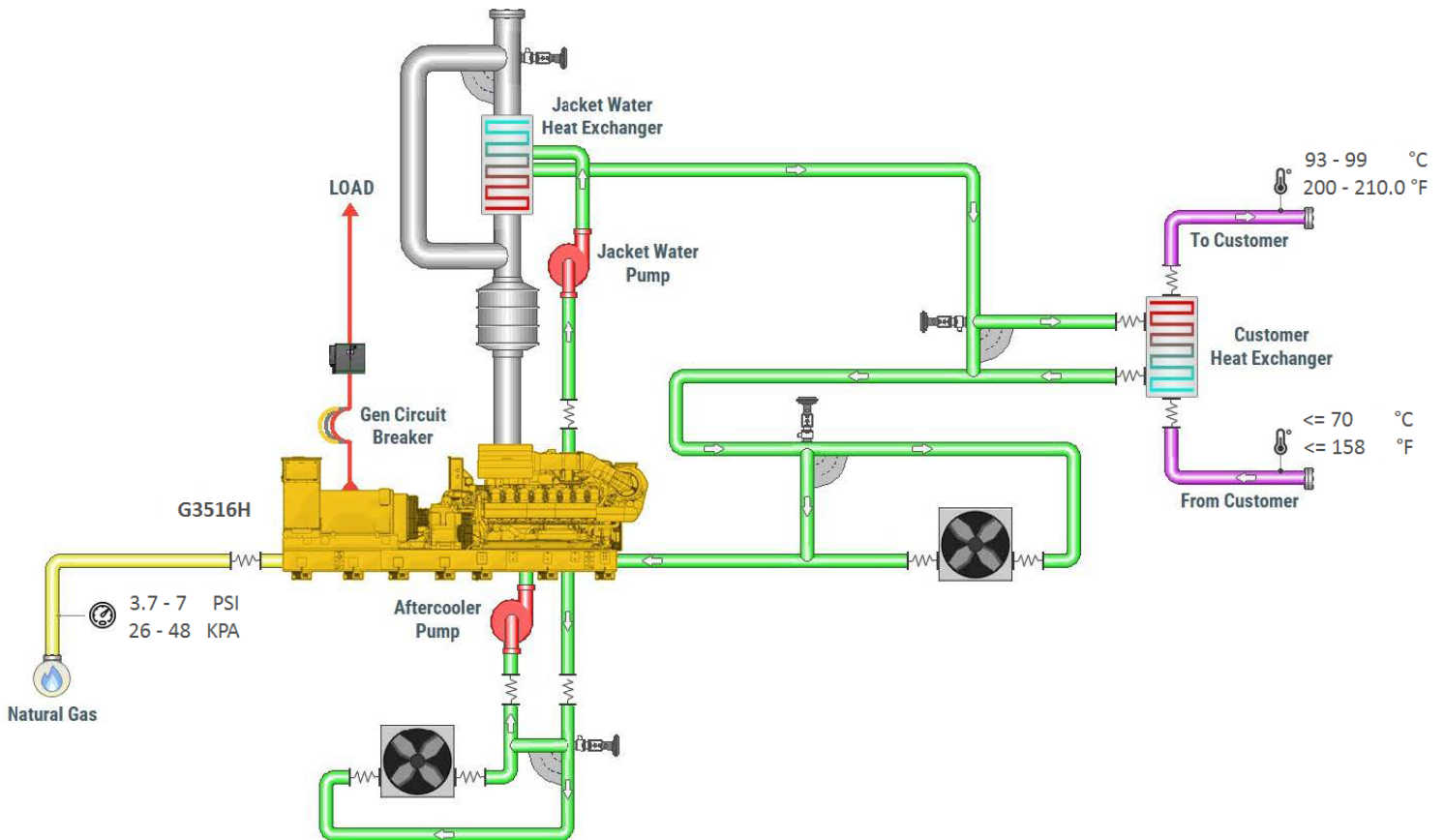

## Enclosure Weights and Dimensions

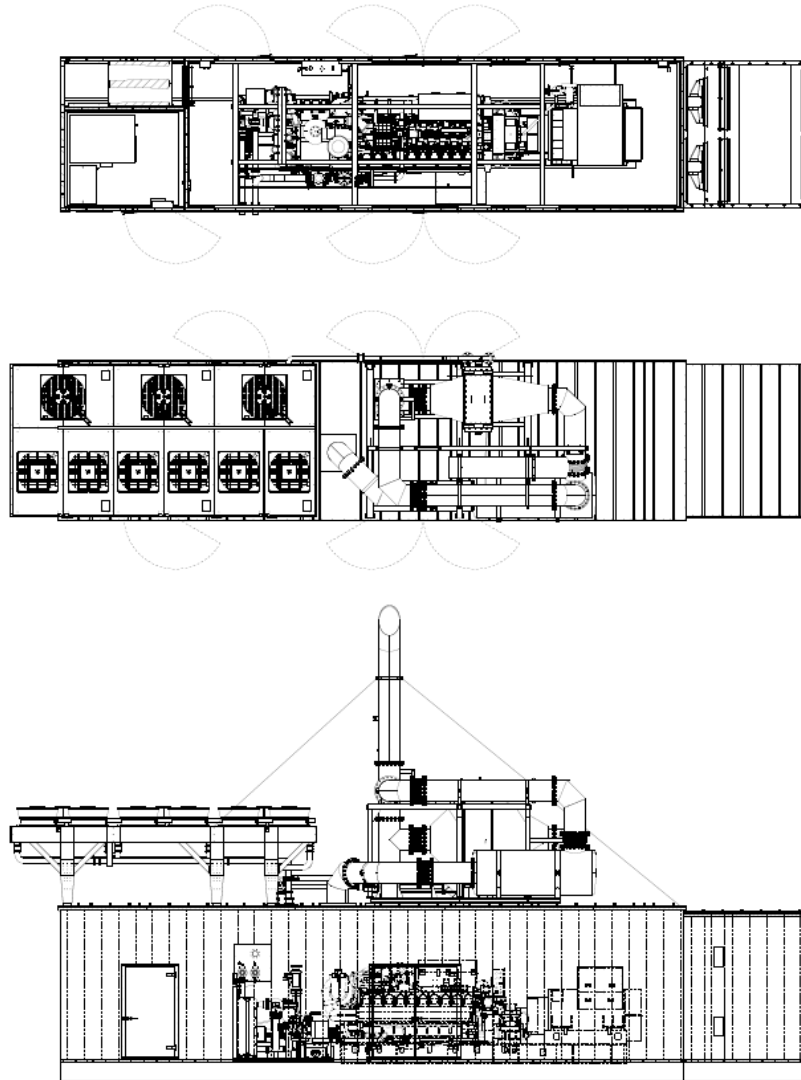

System / Component	Length	Width	Height	Weight
Enclosure	15.25m (50' 0")	3.66m (12' 0")	4.24m (13' 11")	58,000kg (128,000 lbs)
Air Intake Skid	2.95m (9' 8")	3.66m (12' 0")	4.09m (13' 5")	7,400kg (16,300 lbs)
Exhaust Skid	6.58m (21' 7")	3.94m (12' 11")	7.61m (25' 0")	5,600kg (12,400 lbs)
Radiator Skid	7.29m (23' 11")	3.71m ( 12' 2")	2.34m (7' 8")	4,500kg (9,900 lbs)
Installed Dimensions	18.2m (59' 8")	3.94m (12' 11")	11.85m (38' 11")	75,500kg (166,600 lbs)

**Note:** For reference only – not for installation design. Please contact your dealer for exact weights and dimensions

<http://www.cat.com/chp>

Materials and specifications are subject to change without notice.  
The International System of Units (SI) is used in this publication.

© 2021 Caterpillar. All Rights Reserved.

CAT, CATERPILLAR, LET'S DO THE WORK, their respective logos, "Caterpillar Corporate Yellow", the "Power Edge" and Cat "Modern Hex" trade dress as well as corporate and product identity used herein, are trademarks of Caterpillar and may not be used without permission.