

SPM™ Oil & Gas

A Caterpillar Company

**Flow Line Safety
Restraint (FSR)
System**

Operation Instruction
and Service Manual

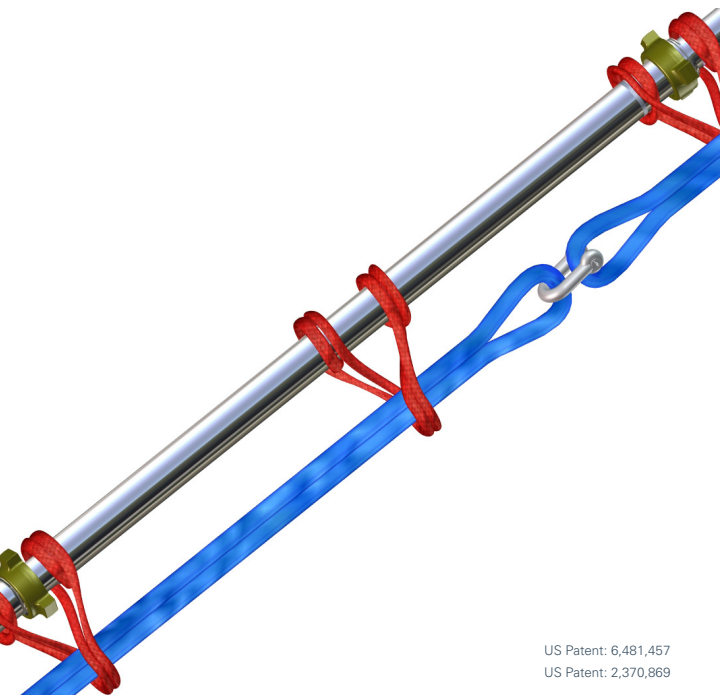

US Patent: 6,481,457

US Patent: 2,370,869

Warning

Important safety information enclosed. Read this operating and maintenance instructions manual before operating product.

This information must be available to all personnel that will operate and maintain equipment. **Failure to read, understand and follow the operating and maintenance instructions manual could result in SERIOUS BODILY INJURY, DEATH, OR PROPERTY DAMAGE.**

Most SPM® products generate, control or direct pressurized fluids; therefore, it is critical that those who work with these products be thoroughly trained in their proper application and safe handling. It is also critical that these products be used and maintained properly!!

SPM® flow products contain elastomeric seals and are not intended to provide proper functionality when exposed to fire.

Warning

Misuse, side loading, improper maintenance, or disassembly under pressure can cause **SERIOUS BODILY INJURY, DEATH, OR PROPERTY DAMAGE.**

The following information is given in good faith and should aid in the safe use of your SPM® products. This information is not meant to replace existing company safety policies or practices.

Personal Responsibilities

1. When working on SPM® flow control products, safety glasses, approved safety shoes and hard hat must be worn.
2. Personnel should never hammer on any component when pressure is present. Hammering on any part or component may also cause foreign material or steel slags to become airborne.
3. It is a personal responsibility to use the proper tools when servicing the valve. It is a personal responsibility to be knowledgeable and trained in the use and handling of tools for all maintenance of the valve.
4. Hot surface may be present; it is a person's own responsibility to protect against burn injury.

—IMPORTANT— READ BEFORE ATTEMPTING USE!

Since most SPM® products generate, control or direct pressurized fluids, it is critical that those who work with these products be thoroughly trained in their proper application and safe handling. It is also critical that these products be used and maintained properly. Any components that show obvious signs of damage or wear should be removed from service immediately.

SPM® Flow Line Safety Restraint (FSR) components are not intended for individual use. SPM® FSR Ribs and Spines are not lifting devices and should never be used as such. Any Ribs or Spines that have been subjected to any loads should be immediately removed from service.

SPM® FSR components are considered “single-use” items. This means that, while these components can be installed multiple times out in the field, if they are actually employed (that is, subjected to trauma as in the event of a union failing or a pipe rupturing), then the affected components need to be replaced immediately.

Always keep ALL personnel away from the flow line while under pressure. This applies even when a restraint system such as the SPM® FSR is in place.

Installation of individual SPM® FSR components as well as the system itself should be done by SPM Oil & Gas personnel or persons qualified by SPM Oil & Gas to do so.

Warning

Observe all instructions, cautions and warnings as noted in this manual. Failure to do so can lead to equipment damage and **SERIOUS BODILY INJURY, DEATH, OR PROPERTY DAMAGE.**

Table of Contents

General Information.....	5
This Service Manual Covers.....	5
Overview of FSR Changes.....	6
Legacy Product.....	7
Product Description.....	8
Applications.....	9
System Components.....	10
Duty Rating and Color Code Charts.....	12
Chemical Compatibility Chart.....	12
Temperature Ratings.....	13
Identification.....	13
RFID.....	14
Maintenance & Storage.....	16
Installation.....	17
Assembly Overview.....	18
Recommended Sequence When Installing FSR Components.....	19
Rib Installation.....	20
Recommended Assembly Aid.....	23
Correct Rib Configuration.....	24
Required Rib Locations.....	25
Spine Linking.....	28
SPM® Bridle Assembly FSR Installation.....	32
Securing SPM® FSR System Ends.....	37
Final SPM® FSR System Inspection.....	40
Inspection and Maintenance.....	41
Inspection & Replacement Guidelines.....	41
Inspecting SPM® FSR Components.....	42
Service and Support.....	45
Service Center Order Information.....	45
Headquarters.....	46

This Service Manual Covers

FRS Spines		
PN	Length (ft)	Color
P23625-04	4	Blue
P23625-06	6	
P23625-08	8	
P23625-10	10	
P23625-15	15	
P23625-20	20	

FRS Ribs		
PN	Length (ft)	Color
P23626-04	4	Red

FRS Shackle Assembly		
PN	Size (in)	Color
P140578	1 1/4 in	Gray

Overview of FSR Changes

The information regarding Flow Line Safety Restraint (FSR) component parts and assembly protocols represent the latest configuration provided by SPM Oil & Gas. Changes to product specifications and assembly protocols are the result of extensive testing and development, including:

- **Extensive full scale assembly testing.** This has led to modifications to the FSR assembly protocol resulting in reduced assembly and disassembly time, and less strenuous work for assemblers.
- **Destructive testing conducted on full scale flow lines at 22,500 psi.** This provided firm evidence that the product is suitable for the published rating applications including changes made to the assembly protocol.
- **Load cell testing to quantify the loads generated during the line separation.** This data has allowed SPM Oil & Gas to develop an accurate calculation matrix for predicting peak loads during a line separation. This data has been verified to correlate with the destructive test results and provides a convenient tool for sizing of the onsite anchor points.

Legacy Product

Production of the legacy Lightweight and Heavy Duty FSR components has been discontinued. However, they can still be used for applications meeting the load ratings as shown below. They are identified on the component by the words “Light Duty or “Heavy Duty”. Those legacy component parts, including Ribs and Spines, as well as assembly protocols published in revision C of the “FSR Installation and Operations Manual” are still fit for purpose per the duty ratings noted below and are qualified for continued use.

Legacy Light/Heavy Duty Ratings		
	Light Duty	Heavy Duty
Nominal Pipe Size (in)	Pressure (psi)	
2"	15,000	30,000
3"	7,500	20,000
4"	5,000	15,000

Legacy FSR shackles are still approved for continued use. See page 15 for more information regarding the difference between legacy shackles and new shackle specifications.

The FSR component parts noted in this revision are consistent with the legacy components defined as the MEDIUM DUTY in previous documents. Any existing Ribs and Spines identified as “Medium Duty” are suitable for the new duty ratings referenced on page 12.

Product Description

The SPM® Flow Line Safety Restraint (FSR) system is designed to help contain high-pressure piping and components in case of rupture during the pumping process. The destructive force of an unrestrained flow line rupture, regardless of the cause, can be devastating and catastrophic to both people and equipment. Metal components that were previously subjected to up to 20,000 psi of internal pressure are instantly forced to relieve that pressure and could become airborne and flail causing severe damage and injuries.

Installation of the FSR system can help producers and well service providers deliver on a commitment to safety at the well site. The FSR system utilizes interlocking synthetic loops strung the length of the flow line (Spine), attached to critical points of the flow line through smaller loops (Ribs). This assembly is then anchored to a substantial structural tie-down, such as the pumping unit or offshore rig structure. Ribs and Spines of the system transmit separation forces to the anchor point and dissipate large amounts of energy over a longer period of time.

The FSR system is suitable for both energized and non-energized fluids, with a maximum application rating of 15,000 psi for 4" flow iron. This design provides engineered flow line protection, while simplifying inventory by eliminating the need to maintain multiple products to accommodate all potential applications.

The SPM® FSR system has been destructively tested on a full scale layout to verify performance at 22,500 psi, using 4-1502 iron components. This testing has helped validate that the product meets the published rating regarding application.

Applications

The SPM® Flow Line Safety Restraint system is intended for all applications involving pressurized fluid or gas. This includes energized fluids, non-energized fluids, fixed and temporary applications. The following is a detailed list of potential applications that are appropriate for use with the SPM® FSR system.

Service Type:

- Nitrogen
- CO₂
- Cementing
- Acidizing
- Slick water
- Foam frac

Applications:

- Treating iron lines
- Well head/riser
- Manifolds and manifold trailers
- Pump discharge bridle assemblies

For more information regarding service types or applications not listed, please contact SPM Oil & Gas Engineering.

System Components

SPM® FSR Ribs (Part numbers referenced on page 5)—Engineered synthetic loops that are designed to be installed at each union connection on a flow line, on swivel articulating joints, and mid-way through long lengths of pipe. See pages 25-27 for more information. Their purpose is to transfer the energy released during a line separation to the main line for dissipation. The non-binding installation procedure also allows the main line to uniformly elongate, resulting in lower loads, and greater energy dissipation capabilities. The ribs are available in two lengths to facilitate proper sizing for all applications ranging from 1" to 4" iron.

SPM® FSR Spines (Part numbers referenced on page 5)—Engineered synthetic loops that are linked together using SPM® shackles, or alternate approved linking method, to create the main load bearing line. This completed assembly is capable of dissipating energy released during a line failure for applications involving 4" iron up to 15,000 psi. This system is similar to a bungee cord and dissipates the energy by elongating under load. The main line should always be secured to an appropriately rated anchor at each end. Spines are available in the following lengths: 4', 6', 8', 10', 15' and 20'.

SPM® FSR Shackles (Part number P140578)—Allow for rapid connection of SPM® Spines to form the continuous main line. These components are optimized for their application and include the following features:

- Compliance with ASTM B30.20
- Alloy steel material to comply with the intended design requirements
- Tested to verify performance at -30°C
- Galvanized coating per ASTM A153
- Locking mechanism to prevent shackle from disengaging
- Proof testing
- Serialization (New Shackles)

System Components cont.

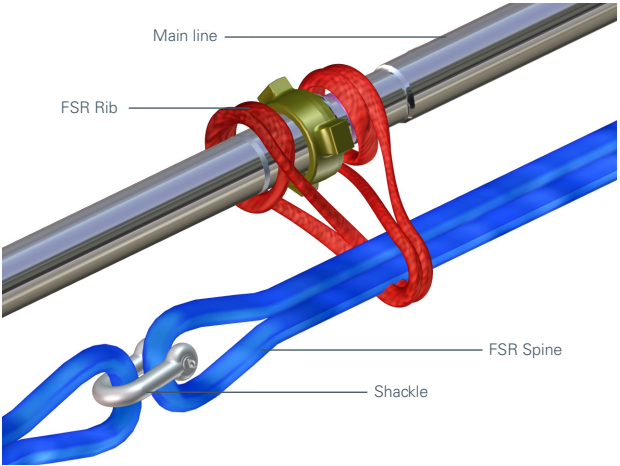

NOTE: It is critical that those who work with SPM® products are thoroughly trained in their proper application and safe handling practices since most products generate controlled or direct pressurized fluids. It is also critical that these products be used and maintained properly.

Duty Rating and Color Code Charts

The following is a summary of the nominal pipe diameters and pressure ratings that are suitable for use with the SPM® Flow Line Safety Restraint system:

Nominal Iron Size (in)	Pressure (psi)
2"	30,000
3"	20,000
4"	15,000

Component Part	Color Designation
SPM® FSR Ribs	Red
SPM® FSR Spines	Blue

Chemical Compatibility Chart

Chemical	FSRs
Acids	*See note
Alcohols	Ok
Strong Alkalis	Ok
Ethers	Ok
Hydro-Carbons	Ok
Ketones	Ok
Oils-Crude	Ok
Oils-Lubricating	Ok
Soaps/Seawater	Ok
Water/Seawater	Ok
Weak Alkalis	Ok

* Acid Compatibility – Hydrochloric Acid (HCl):

Concentrations up to 36% acceptable for up to 8 hours. Hydrofluoric Acid (HF):

Concentrations up to 10% acceptable for up to 8 hours. (Note that all chemical exposures are assumed to be at ambient temperature.) For other acids or chemicals not stated, please contact SPM Oil & Gas Engineering.

Temperature Ratings

Minimum: -40° C / -40° F

Maximum: 110° C / 235° F

* Maximum temperature is based on the surface temperature of the iron.

Identification

SPM® FSR components are permanently identified with an orange tag that is sewn into the assembly. Each Rib and Spine will have a label as shown below. The type of component will be identified on the tag as "RIB" or "SPINE". The size of the component will also be noted on the label. Components are identified with their VENDOR ID (SPM Oil & Gas), PART NUMBER, SIZE and SERIAL NUMBER on the label permanently attached to each component.

Finalization of the annual inspection process requires "punching" the identification tag to indicate the quarter and year in which the inspection was completed as illustrated below.

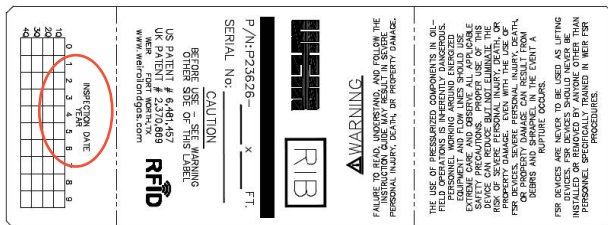

FSR Tag

NOTE: If this tag is removed from the component part or it is no longer legible, please discard.

RFID

(Radio Frequency Identification)

All new SPM® FSR components will soon be equipped with a RFID tag that will allow for more effective inspection and inventory control. Illustrated below is the RFID installation location under the orange identification label. FSR components with RFID installed from factory will be noted on the identification tag as shown prior.

Existing FSR may be retrofitted with a RFID tag per Engineering Specification 4S41504.

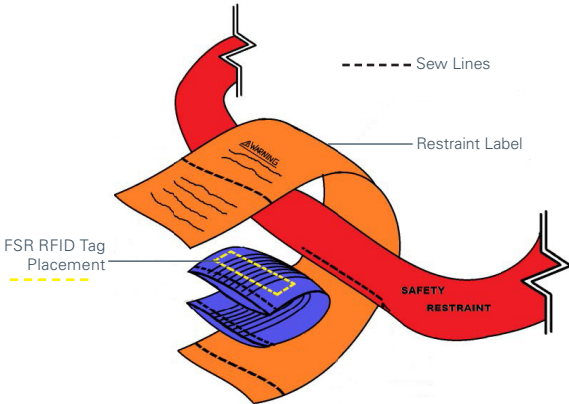

RFID

(Radio Frequency Identification cont.)

Serialization (Shackles)

All new shackles with part number P140578 will have full traceability as shown below.

Identification will include:

- Manufacturer
- Serial Number
- Working Load (tons)
- Size (in)

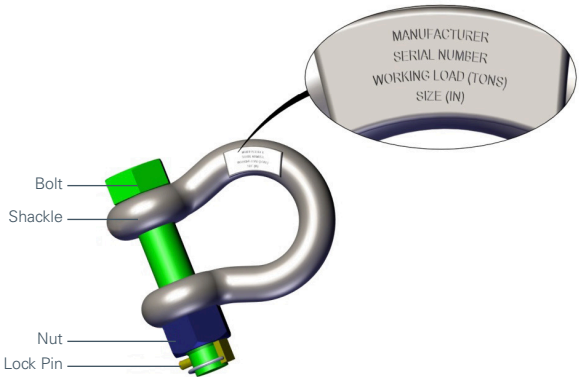

NOTE: legacy shackles with part number 2a29795 are still acceptable for continued use, but may not be identified with information as shown above.

Maintenance & Storage

SPM® FSR components generally do not require any special maintenance to keep them in service. Even though they are water resistant, the components should NOT be used underwater or submersed in water. If they are in an environment where they get wet, it is recommended that they are wiped dry after each use with a clean, dry cloth.

It is recommended to store SPM® FSR components and associated equipment in a dry place. However, exposure to water will not reduce the load capacity of the components; it will only make them slightly heavier.

General Installation Notes for SPM® Flow Line Safety Restraint System (FSR)

Installation of individual SPM® FSR components as well as the system itself should be done by SPM Oil & Gas personnel or persons qualified by SPM Oil & Gas to do so.

Any misuse of the SPM® FSR components such as lifting or towing, or improper installation shall void any and all warranties and may cause injury or death. Further, any mishandling of the SPM® FSR components such as not following the maintenance and care instructions contained in this guide void all warranties.

Prior to installation, verify that the tag indicates the component has undergone inspection within the last year.

For the most efficient setup, install SPM® FSR Ribs and Spines in unison with the flow line rig-up. After SPM® FSR is installed, check every connection, every link, and every SPM® FSR component to verify that there is a continuous connection from anchor point to anchor point.

After the complete SPM® FSR system is installed, verify:

- All SPM® FSR Ribs are securely installed secure around flow line components.
- All main lines are secure around anchor points.
- Always keep ALL personnel away from the flow line while under pressure. This applies whether or not a restraint system is installed.

Warning

Do not use or substitute non-SPM® components as replacements or in addition to SPM® Flow Line Safety Restraint components. Only SPM® components may be used in a SPM® Flow Line Safety Restraint installation.

Assembly Overview

1. Position and wrap Ribs at each hammer union/Safety Iron® connection and at additional required locations as noted on pages 24-26.

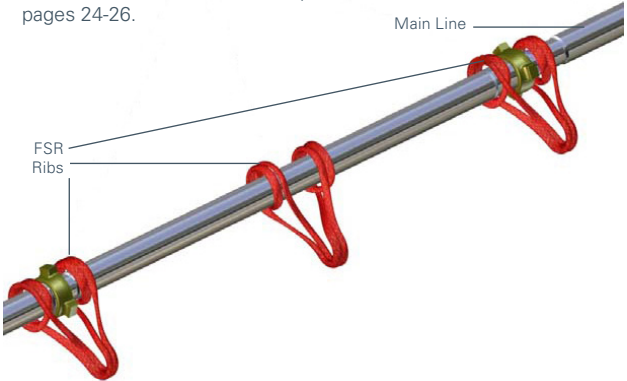

2. Install Spines on anchor points located near each terminating end of the flow line. This would include anchoring around the base of the wellhead and on the back of a frac pump or manifold trailer. Refer to "Securing SPM® FSR System Ends" section on page 37-39 for reference.
3. Run Spine through Ribs and connect Spines together with a Shackle as shown below, or by alternate Spine linking method as referenced on page 28-31.

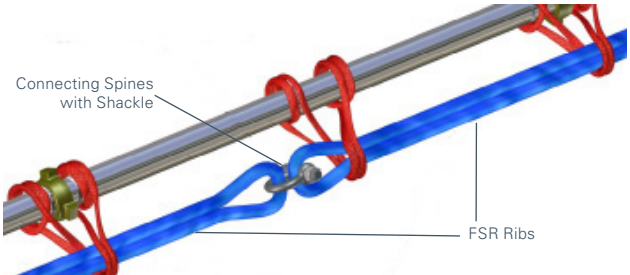

Recommended Sequence When Installing FSR Components

Different situations require different installation sequences. The possibilities are myriad and each scenario cannot be discussed in this manual. Should you have any questions regarding proper installation, it is strongly recommended you contact SPM Oil & Gas Engineering before proceeding. A standard installation sequence is as follows:

First

Install the SPM® FSR Ribs. See page 18 of this guide for more information.

TIP—It is most efficient to have one person lay out all the SPM® FSR Ribs at appropriate locations along the flow line prior to installing them.

TIP—It is recommended that one person lift the flow line with a pipe jack (or similar leverage) while another individual installs the Rib at each wing union connection.

Second

One end of the Spines will be used to secure the FSR System as shown on pages 37-39. Once one end of the Spine is installed on a secured anchor point the other end will be run through the already installed Ribs. If additional Spines are needed they can be linked by the following ways:

- Shackles (Shown on page 28)
- Alternate Linking Method (Shown on page 28-31)

Rib Installation

Step 1

Begin by positioning the Rib beneath the flow line as shown. The Rib profile should straddle the union assembly.

NOTE: Piping might require elevation in order to fit the rib beneath—
See page 23 “Recommended Assembly Aid” for complete details.

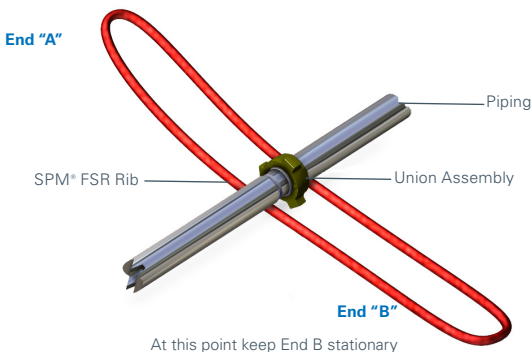

Step 2

Next, bring end "A" up and over piping and union assembly. Insert end "A" down through end "B" opening. Pull "A" back through to original side as shown.

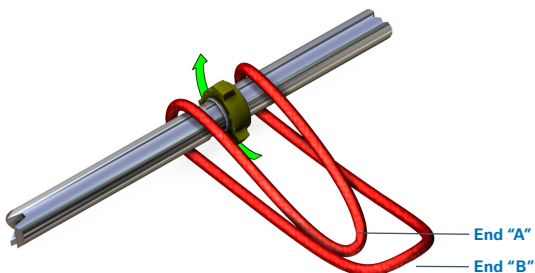

Rib Installation cont.

Step 3

Continue to bring end "A" back around to form a second loop. Rib profile should still evenly straddle union assembly as shown.

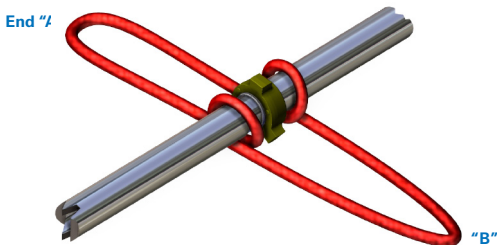

Step 4

Draw end "A" even with "B" end as shown. Ensure that the Rib profile fits snug around union assembly (or other applicable connection). This Rib is now ready for Spine Installation (See page 28-31 for correct Spine information).

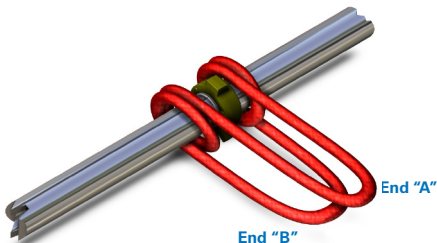

Rib Installation cont.

NOTES: Rib profile must always straddle each side of wing union connection. This configuration provides the most purchase to contain flow line components on either side if the union fails. SPM® FSR Ribs can NEVER be substituted for SPM® FSR Spines. SPM® Ribs are available in two lengths to allow for optimal fit during installation. The following chart provides guidelines for selecting the proper Rib. SPM® Ribs may be linked together using a hitch knot to allow for attachment to larger, non-standard components.

Iron Size (in)	Rib Length (ft)
2" 1502	
2" 15,000 Safety Iron	
3" 1502	4 ft
3" 15,000 Safety Iron	
4" 10,000 Safety Iron	
4" 1502	4 1/2 ft
4" 15,000 Safety Iron	

Recommended Assembly Aid

It is typically necessary to raise the flow line piping in order to insert Ribs between union connections and the ground. Never attempt to lift piping manually. The suggested method is to use a "pipe jack". A secondary method is to use a lever and fulcrum. Place lever under flow line as shown and temporarily lift piping to a minimal height using the following guidelines for reference.

Do not lift piping more than 6-8 inches. More than this increases the potential of loosening the union seal connection. Never extend any part of your body underneath the piping while it is elevated. Sometimes an opposing force is required from the side opposite the lever. A second lever may be used. Make sure that piping is still in a straight line after lowering back to ground. If piping or components are askew, there is potential of leakage through union assemblies.

Do not lift piping while flow line is under pressure.

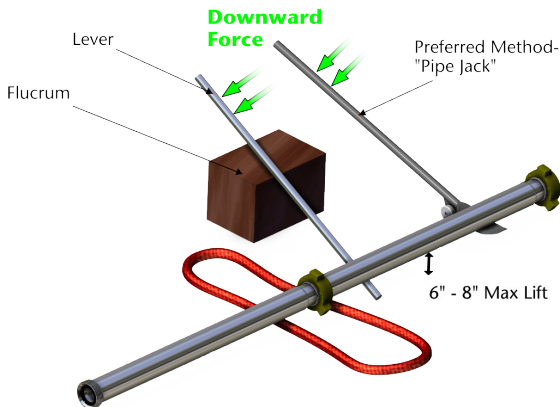

Correct Rib Configuration (Shown with SPM® FSR Spine Installed)

The SPM® FSR System has been designed to allow for “slack” during the installation of the Ribs. This position has been validated by destructive testing at 22,500 psi with 4” flow iron. Due to this, SPM® does not require “twisting” the rib, prior to installation of the main line. However, the “twist” technique may be used for special application requiring reduced slack. Please note that any reduction in slack is not required to achieve the desired performance, but is purely a cosmetic benefit. This is illustrated below for reference.

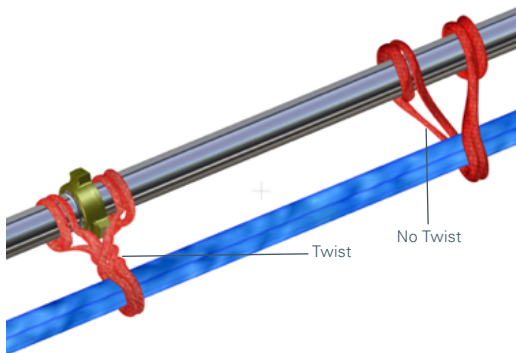

Required Rib Locations

Union Connections

SPM® FSR Ribs should be installed on EVERY union connection on the flow line (one Rib per union). The Rib envelope must always straddle both sides of the union in order to help contain each end of the adjoining pipes/components. The maximum rib spacing **cannot exceed 10 feet**.

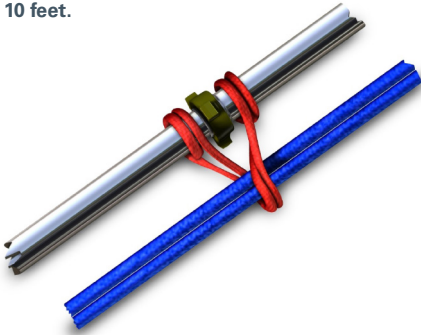

Flow Line Components

Virtually all flow line components utilize two wing union connections—usually male x female. Therefore, most flow line components (check valve, plug valve, etc.) requires SPM® FSR Ribs installed at each end as shown.

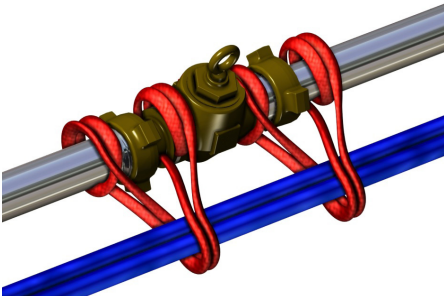

Required Rib Locations cont.

Long Piping Assemblies

Most piping assemblies can be treated like other flow line components—with one SPM® FSR Rib installed on each union connection at each end. However, on piping assemblies 20 feet or longer, SPM Oil & Gas requires that a third SPM® FSR Rib also be installed midway between the two union connections as shown. This center Rib will not have the union connection to help prevent it from sliding, however, field testing has shown that this Rib will help provide extra support should a failure occur.

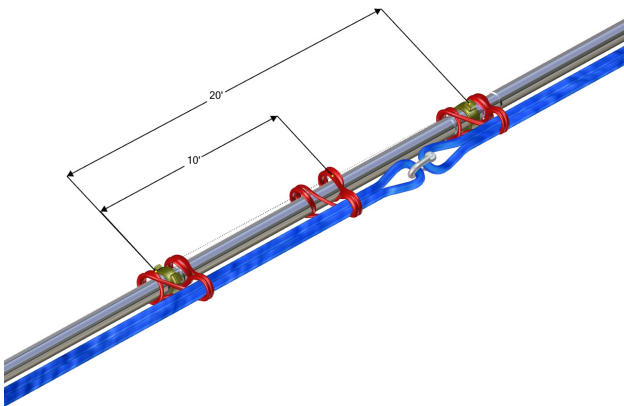

Required Rib Locations cont.

Swivel Assemblies

Swivel assemblies should have SPM® FSR Ribs installed at each of the following locations:

- One at each union connection
- One additional Rib for each additional articulating joint (excluding the joint adjacent to each union connection).

This will result in the following arrangement:

- Style 50 Three ribs
- Style 10 Three ribs
- Style 100 Four ribs

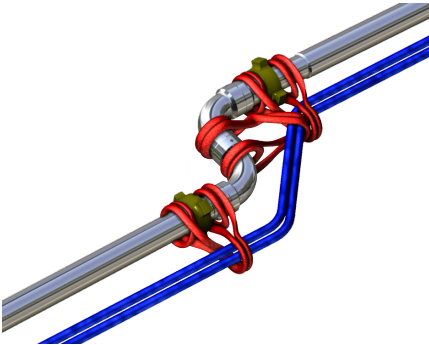

Spine Linking

USE THIS PROCEDURE TO LINK SPINE RESTRAINTS TOGETHER TO CREATE ONE MAIN LINE (OR ANCHOR LINES)

Lay out SPM® FSR Spines end to end and connect them with a shackle as shown below.



NOTE: SPM® recommends the use of the SPM® shackle for linking Spine components. This approach has been validated through destructive testing and provides reduced assembly and disassembly times. However, the installer may use the alternate linking method shown following.

Optional Linking Method

Step 1

- Lay out SPM® FSR Spines end to end as shown. For illustration purposes, we will consider ends "A" thru "D" for this procedure.

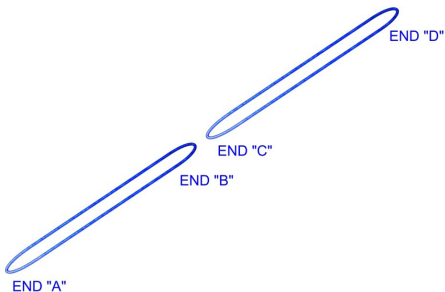

Spine Linking cont.

Optional Linking Method

Step 2

- While keeping the "B" end stationary, draw "C" end thru as shown.

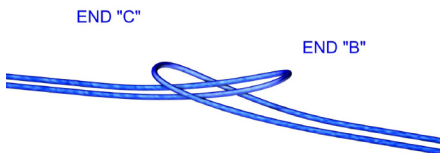

Optional Linking Method

Step 3

- Continue to pull "C" end thru "B" end. Insert "C" end back thru the "C-D" SPM® FSR Spine as shown. As "C" is pulled further, unrestrained "D" end will move towards "B" end.

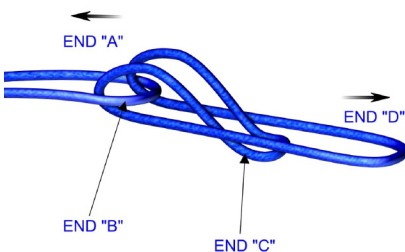

Spine Linking cont.

Optional Linking Method

Step 4

- Pull the remainder of "C" end thru until "D" end draws close to "B" end as shown. While holding "B" end stationary, (using either a second person or placing a weight on the "A/B" SPM® FSR) pull "C" end the remainder of the way through.

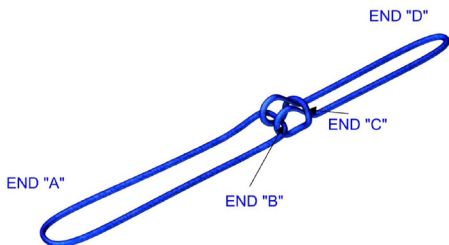

NOTES:

Optional linking method is described in the above procedure. **NEVER** tie knots in SPM® FSR components. Use only the linking method to attach restraint ends to each other.

Every Spine-to-Spine link must be tight. This is critical in establishing an overall tight SPM® FSR main line installation. This linking procedure generally applies only to SPM® FSR Spines. However, SPM® FSR Ribs can be linked in the same manner if a single Rib is too short to encircle a larger component.

SPM® FSR Spines are rated at over twice the strength of v FSR Ribs. Spines and Ribs should **NEVER** be linked together. SPM® FSR Ribs are **NEVER** to be substituted for SPM® FSR Spines. Linked Spines should run parallel down the main line and not twist or be wrapped around the flow line.

Spine Linking cont.

Optional Linking Method

Step 5

- With "C" end pullet taut, notice how "D" and "C" ends have switched places. While keeping "A/B" ends stationary, keep pulling "C" end until the "B/D" connection can no longer be tightened. SPM® FSR link should look like detail shown.

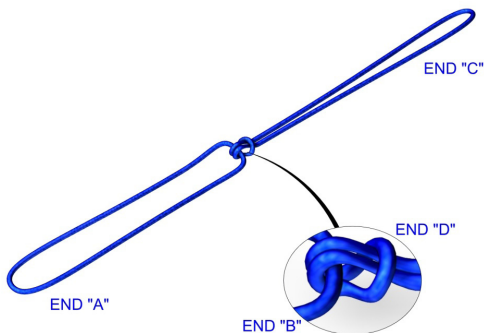

SPM® Bridle Assembly FSR Installation

While each frac truck and bridle assembly is different, the below process should be used and applied as closely as possible.

Equipment

Installation of SPM® FSR on the wrap around bridles requires the following:

Part number	Description	Quantity
P23626-04	4 ft long rib	8-10 Based on configuration*
P23625-08	8 ft long spine	1
P23625-20	20 ft long spine	1
P140578	Anchor Type Shackle	2

*SPM® Rib required on every hammer union, SPM® Safety Iron®, swivel ball race, and middle of 20 ft or longer straight joints of the bridle

Step 1

Begin by installing ribs on all hammer union connections, SPM® Safety Iron® connections, swivel ball articulating joints, and in the middle of all 10 ft. and longer straight joints of the bridle assembly.

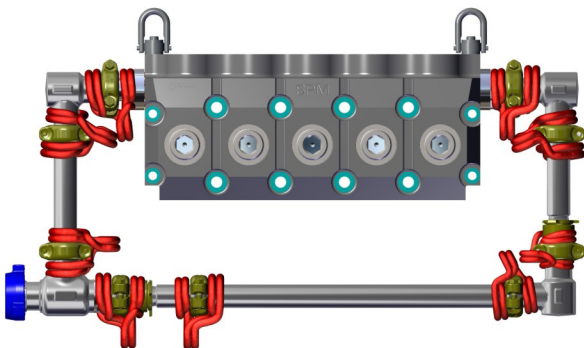

Ribs shown wrapped around all connections along bridle assembly

SPM[®] Bridle Assembly FSR Installation cont.

Step 2

Once the Ribs are installed, we are going to begin with the short side of the wrap around bridle. This is going to be the same direction the bridle is running off the truck. Start with the main line going around the frame of the frac pump/truck and shackling back to itself. The frame needs to be able to withstand at least 30,000 lb load.

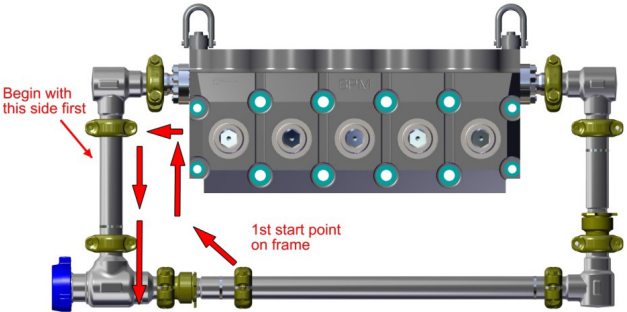

Spine starting point and direction of travel

SPM[®] Bridle Assembly FSR Installation cont.

Step 3

Make sure the Spine is as tight as possible when wrapping it around the anchor point on the frame. The short side of the bridle uses the 8 ft. line. The figure below shows what the assembly should look like.

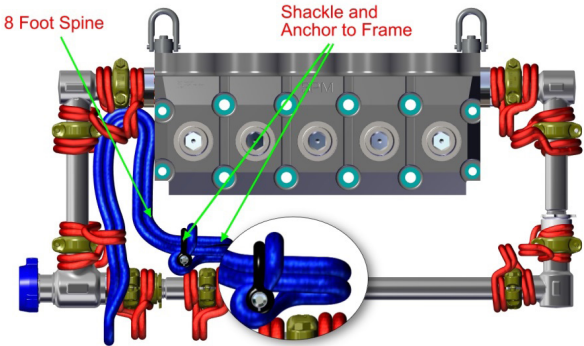

8ft. Spine running along the short side of the bridle

SPM[®] Bridle Assembly FSR Installation cont.

Step 4

Next, take the 20 ft. main line going around the frame of the frac pump/truck and shackle it back to itself. This will be on the long side of the bridle opposite of the line running back off the truck

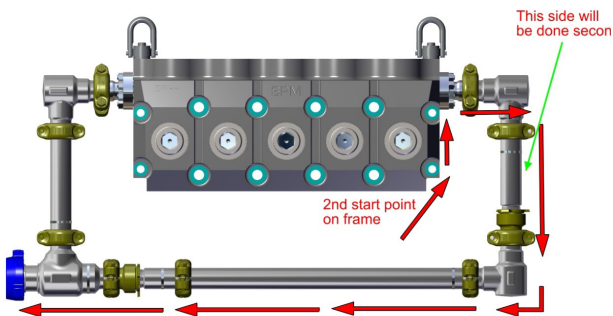

20 ft. Spine starting point and direction of travel

SPM[®] Bridle Assembly FSR Installation cont.

Step 5

Run the 20 ft. Spine through all of the ribs along the long side of the bridle. Then run the 20 ft. line through the 8 ft. line as it passes the short side of the bridle. If the 8 ft. line is too long and there is some slack, begin to twist the line until it shortens and becomes tight. Once the line is tight, you can run the longer line through and continue the line along the assembly to the manifold trailer.

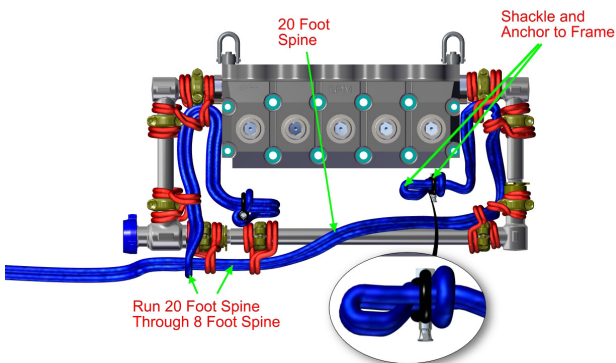

20 ft. line running along the long side of the bridle and through the 8 ft. line

Securing SPM® FSR System Ends

There are two primary methods for securing the SPM® FSR main lines:

Looping

Looping the SPM® FSR Spine around the anchor point, then back through itself (Note: tying to an anchor point is never acceptable).

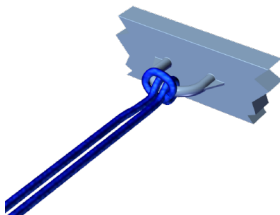

20 ft. line running along the long side of the bridle and through the 8 ft. line

Securing SPM® FSR System Ends cont.

“C” Shackle

Looping the SPM® FSR Spine around the anchor point, then utilizing an anchor shackle to secure the end back to the SPM® FSR Spine.

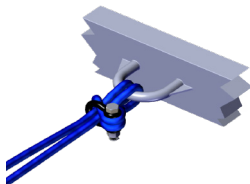

- * **CAUTION:** Sharp edges should always be avoided in all SPM® FSR installations. When connecting to a rig/trailer frame or undercarriage, make certain that these surfaces are smooth and do not have sharp edges. Never loop or shackle restraints to pressure lines as an anchor point.
- ** While large rig axles can be an acceptable source to anchor an SPM® FSR line, if the axle is too oily or greasy, it is generally preferable to select an alternative anchor point to save cleaning time later.
- *** When securing an SPM® FSR system to an axle, make sure the anchor point is a substantial member. Also, take care to avoid damaging more intricate rig suspension components.

Securing SPM® FSR System Ends cont.

IMPORTANT NOTE: SPM Oil & Gas requires that the anchor location selected for terminating the FSR be capable of resisting the maximum shock load generated by the iron separation. This value is a function of the inner diameter of the flow iron, the length of the continuous spine, and the maximum fluid pressure. The following chart provides guidelines regarding selecting the appropriate anchor load rating based on application conditions:

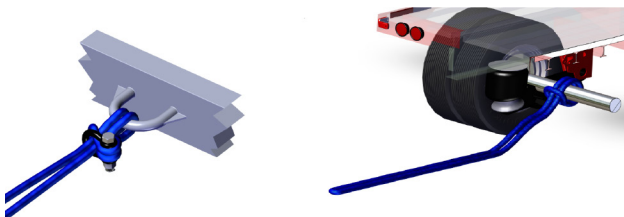

Nominal pipe size (in)	Fluid pressure (psi)	Anchor rating (lbs)
2" / 3"	15,000 psi	30,000 lbs
4"	15,000 psi	40,000 lbs

* This rating is suitable for both energized and non-energized fluids

* Contact SPM Oil & Gas Engineering for additional support regarding anchor recommendations

Final SPM[®] FSR System Inspection

(Always done before pressurizing the flow line)

Make sure that the main SPM[®] FSR line is continuous, meaning that all SPM[®] FSR main line ends are secured to an appropriate anchor. This is important. If there is a break in the flow line, any discontinuity in the SPM[®] FSR main line could allow flow line components to move violently.

Verify that the SPM[®] FSR main line is tight as possible.

Make certain that there are no sharp edges that could wear down, fray, or otherwise sever any of the SPM[®] FSR lines. This is especially true at anchor points such as a truck or trailer frame.

Bleed-off (or blowback) lines should be secured with the SPM[®] FSR System in the same manner as the main flow line.

NOTE: It is imperative that all SPM[®] FSR components are inspected before each installation. Damaged or otherwise unusable SPM[®] FSR components should be discarded and replaced.



Inspection & Replacement Guidelines

Over time, due to the nature of their handling and use in the field, SPM® Flow Line Safety Restraint Ribs and Spines may become worn or damaged. Therefore, it is critical that they are regularly inspected for noticeable damage, and are required to undergo an annual inspection performed by SPM® personnel. In addition, the regular inspection process includes a visual inspection of the restraints prior to installation on every job. Inspection criteria are described below. Further information regarding the annual inspection process can be found in Engineering Specification 4S24036.

The sheath plays an important role in protecting the critical load bearing core from degradation. Any visible sign of physical damage or wear may indicate that the integrity of the load bearing core has been compromised. In addition, the outer sheath is designed to tear if the restraint has been exposed to any significant loading. Therefore, any overload of the restraint will result in a damaged outer sheath.

Ribs and Spines cannot be repaired and any SPM® FSR component that exhibits a damaged or worn outer sheath is considered unacceptable and should be discarded immediately. Failure to follow this policy may result in the component failing prematurely and not meeting design intent.

Finalization of the annual inspection process requires “punching” the identification tag to indicate the quarter and year in which the inspection was completed as illustrated below.

<p>INSPECTION DATE</p>	<p>BEFORE USE - SEE WARNING ON OTHER SIDE OF THIS LABEL</p> <p>US PATENT # 6,481,457 UK PATENT # 2,370,809 MER FORT WORTH, TX www.merrolandgps.com</p> <p>RFID</p>	<p>P/N: P23526-_____ X _____ FT.</p> <p>SERIAL No: _____</p> <p>CAUTION</p>	  <p>WARNING</p> <p>FAILURE TO READ, UNDERSTAND AND FOLLOW THE INSTRUCTION GUIDE MAY RESULT IN SEVERE PERSONAL INJURY, DEATH, OR PROPERTY DAMAGE.</p>	<p>THE USE OF PRESSURIZED COMPONENTS IN OIL-FIELD APPLICATIONS REQUIRES THAT ALL PERSONNEL WORKING AROUND ENERGIZED EQUIPMENT AND FLOW LINES SHOULD USE EXTREME CARE AND OBSERVE ALL APPLICABLE SAFETY PRECAUTIONS. PROPER USE OF THIS DEVICE CAN REDUCE BULLYING INJURY, DEATH, OR PROPERTY DAMAGE EVEN WITH THE USE OF FSR DEVICES. SEVERE PERSONAL INJURY, DEATH, OR PROPERTY DAMAGE CAN RESULT FROM DEBRIS AND BRANCHED IN THE EVENT A RUPTURE OCCURS.</p> <p>FSR DEVICES ARE NEVER TO BE USED AS LIFTING DEVICES. FSR DEVICES SHOULD NEVER BE INSTALLED OR USED BY ANYONE OTHER THAN PERSONNEL SPECIFICALLY TRAINED IN THEIR FSR PROCEDURES.</p>
------------------------	---	--	--	---

Inspecting SPM[®] FSR Components

FSR Spines and Ribs

Inspect each component before every use. Also, to enhance safety, qualified personnel should inspect the complete installation before every use.

The following is a list of visual criteria used to assess the suitability of the FSR component for additional use:

- Any damage to the SPM[®] FSR cover where internal redstriped white core yarns are exposed (This includes cuts, holes, tears, snags, abrasions or other damage to cover).
- The FSR tag is missing or has become illegible.
- Knots or other modifications to any part of the FSR.
- Melting, charring, or other indications of excessive heat to any part of the SPM[®] FSR.
- Acid, caustic burns or other signs of chemical deterioration to the SPM[®] FSR.
- Any SPM[®] FSR that has been stretched beyond its original design length or deformed or otherwise misshapen.
- Any other visible damage which causes doubt as to the strength of the SPM[®] FSR.



Damaged FSR Ribs & Spines should be immediately removed from service.

Inspecting SPM® FSR Components cont.

Damaged FSR Ribs & Spines should be immediately removed from service

SPM® FSR are considered “single-use” items. This means that, while these components can be installed multiple times out in the field, if they are actually employed (that is, subjected to trauma as in the event of a union failing or a pipe rupturing), the affected equipment needs to be replaced immediately.

The SPM® FSR Spines and Ribs are designed so failures are normally visible. If there are any signs of damage, the affected components must be replaced. Any other visible damage which causes doubt as to the strength of the SPM® FSR.

NOTE: Upon removal, note the serial number for your records, cut the restraint in half, remove the tag, and discard.

Any FSR component should be removed from service five (5) years after commission.

Inspecting SPM® FSR Components cont.

Anchor Shackles

SPM® Shackles (P140578) require periodic inspection consistent with the requirements of ASTM B30.20-2010 Section 26.1.8 referenced below:

The inspection interval should not exceed 1 year.

- A visual inspection should be performed by the user prior to each installation.
- Remove shackles from service if inspection indicates the following damage:
 - Missing or illegible manufacturer name or rated load indication
 - Indications of welding or other repair
 - Excessive pitting or corrosion
 - Bent, twisted, distorted, stretched, elongated, cracked, or broken load bearing components
 - Excessive nicks or gouges
 - Incomplete pin engagement
 - Thread damage
 - The serial number of the pin and body do not match
- Any repairs or modifications are not allowed.
- The shackles are provided as certified assemblies. Missing bolts cannot be replaced and will result in removal from service.
- Locking nuts and pins may be replaced.

NOTE: All legacy shackles are acceptable for use with the FSR System. However, it is recommended that if the customers require full serialization of the shackles then the new shackles (PN: P140578) shall be used. Contact Engineering for further details.

Service Center Order Information

SPM Oil & Gas stocks a large inventory of genuine original equipment replacement parts. In order to expedite a parts order and avoid any delays, please provide the following information with your order:

- The part number and description (refer to drawings and parts lists in this section) of each item ordered.
- The quantity of each part, kit, or assembly ordered.
- The model number and serial number.
- Your purchase order number.
- Specify method of shipment, complete shipping address, complete billing address and telephone number at the destination of the shipment.

Headquarters

601 Weir Way
Fort Worth, TX 76108
USA

T +1 800 342 7458

F +1 817 977 2508

www.spmoilandgas.com

SPM™ Oil & Gas

A Caterpillar Company

601 Weir Way
Fort Worth, TX 76108
USA

T +1 800 342 7458
F +1 817 977 2508

www.spmoilandgas.com

Document P/N: 2P37221

Revision: G | Date: 03/01/2021