



D3 SERIES SKID STEER LOADER, COMPACT TRACK LOADER AND MULTI TERRAIN LOADER PARTS REFERENCE GUIDE

LET'S DO THE WORK.™



» PROTECT YOUR INVESTMENT WITH GENUINE CAT® PARTS

Thank you for selecting the Cat® D3 Series Skid Steer, Compact Track or Multi Terrain Loader.

This guide is designed to provide you with a quick reference for the parts and part numbers you need to keep your Cat machine running at peak efficiency. Always read and understand the machine's Operation and Maintenance Manual prior to performing any type of maintenance.



MAINTENANCE

Preventive maintenance extends the life of your machine and protects your investment. Only Caterpillar knows Cat equipment's filtration and lubrication requirements and offers parts kits to match your machine's maintenance cycles.

| SCHEDULED REPAIR PARTS | |
|---|-----------------------|
|  | GREASES |
| | DIESEL EXHAUST FLUIDS |
| | PLANNED MAINTENANCE |

REPLACEMENT PARTS

Proper maintenance minimizes the need for repair and replacement. In the event that replacement parts are required, the use of genuine Cat parts helps maximize machine performance and maintains high resale value.

| WEAR PARTS | |
|---|--|
|  | RUBBER TRACK OFFERINGS |
| | FLEXPOR TIREs |
| | UNDERCARRIAGE PARTS |
| | GROUND ENGAGING TOOLS |
| REPAIR PARTS | |
|  | BATTERIES |
| | ENGINE PARTS |
| | CAB GLASS |
| | LIGHTS |
| ENHANCEMENT PARTS | |
|  | QUICK DISCONNECTS |
| | LINKAGE PINS, BEARINGS AND ACCESSORIES |

GREASES

| Previous Cat Product Name | STANDARD MAINTENANCE GREASES | | |
|------------------------------|----------------------------------|----------------------------------|------------------------------|
| | Cat Ultra5 Moly #1 | Cat Ultra5 Moly #2 | Cat Advanced 3 Moly |
| Current Cat Product Name | Cat Extreme Application Grease 1 | Cat Extreme Application Grease 2 | Cat Prime Application Grease |
| Grade (NLGI) | 1 | 2 | 2 |
| Melting Point C° (F°) | 260 (500) | 260 (500) | 260 (500) |
| Ambient Temperature C° (F°) | -35 to +40 (-31 to +104) | 30 to +50 (-22 to +122) | -20 to +40 (-4 to +104) |
| Base Oil Type | Mineral | Mineral | Mineral |
| Color | Dark Grey | Dark Grey | Dark Grey |
| Cartridge (390 g / 14 oz) | 452-5996 | 452-6001 | 452-6006 |
| Plastic Pail (5 kg / 11 lb) | — | — | — |
| Plastic Pail (16 kg / 35 lb) | 452-5999 | 452-6004 | 452-6009 |
| Keg (55 kg / 120 lb) | 452-5998 | 452-6003 | 452-6008 |
| Drum (180 kg / 400 lb) | 452-5997 | 452-6002 | 452-6007 |



| GREASES FOR UNIQUE APPLICATIONS AND ENVIRONMENTS | | | |
|--|---|--------------------------|--|
| Cat Arctic Platinum | Cat Desert Gold | Cat Multipurpose | Hammer Paste |
| Cat Extreme Application Grease - Arctic | Cat Extreme Application Grease - Desert | Cat Utility Grease | |
| 0 | 2 | 2 | 2 |
| 230 (446) | 280 (536) | 260 (500) | 230 (446) |
| -35 to +40 (-31 to +104) | 30 to +50 (-22 to +122) | -30 to +40 (-22 to +104) | -20 to +1100 (-4 to +2012) |
| Semi-Synthetic | Mineral | Mineral | Mineral |
| Dark Grey | Dark Grey | Blue | Bronze |
| 508-2184 | 452-6016 | 452-6011 | 130-6951 (standard) 317-8491 (autolube) |
| — | — | — | 133-8807 |
| 508-2187 | 452-6019 | 452-6014 | — |
| 508-2186 | 452-6018 | 452-6013 | — |
| 508-2185 | 452-6017 | 452-6012 | — |



DIESEL EXHAUST FLUIDS

Cat diesel exhaust fluids ensure that your machine meets all U.S. EPA Tier 4 Final and EU Stage V requirements while saving you time and fuel during recharge cycles.

| PART NUMBER (32.5% UREA) | CONTAINER SIZE |
|--------------------------|-------------------------------|
| 350-8733 | 9.4 Liter (2.5 gallon) |
| 350-8734 | 1,000 Liter tote (264 gallon) |

PLANNED MAINTENANCE

| SKID STEER LOADER | | 500 Hours | | | | | | | | | | 1,000 Hours | | | 1,500 Hours | 3,000 Hours | | | | | |
|----------------------|----------------------|--------------------------|-----------------------------------|-----------------|-------------------|--------------------|-----------------|--------------------------|------------------|-------------------|-----------------------|---------------------|----------------------|-----------------------------|----------------|-------------|--|------------------|--------------------------------------|----------|----------|
| | | Engine Oil/Filter Change | | Air Filter | | Fuel Filter Change | | Lubricate Machine | Hydraulic Tank | Cabin Air* | | Cabin Air* | Engine | Hydraulic Oil/Filter Change | | | Drive Chain Oil | Engine Crankcase | Hydraulic Oil** | | |
| Sales Model | Serial Number Prefix | Filter | Oil Quantity Liter (gal) DEO-ULS™ | Primary Element | Secondary Element | In-line Element | Primary Element | Prime Application Grease | Breather Element | Fresh Air Element | Recirculating Element | A/C Compressor Belt | Belt | Filter Element | Seal (Housing) | Seal (Plug) | Oil Quantity Liter (gal) DEO-ULS™ (ea) | Breather Element | Oil Quantity Liter (gal) Hydo Adv 10 | | |
| 226D3 | DX8, D5R | 220-1523 | 9 (2.4) | 415-2592 | 415-2593 | | | | 420-9748 | | | | | | | | 7 (1.9) | 443-0374 | 35 (9.2) | | |
| | EK5 | | | 526-3118 | 526-3122 | | | | | | | | | | | | | | | | |
| 232D3 | HRS, D5Z | | | 415-2592 | 415-2593 | | | | | | | | | | | | | | | | |
| | GJ5 | | | 526-3118 | 526-3122 | | | | | | | | | | | | | | | | |
| 236D3 | KXL, GK6 | 377-6969 | 12 (3.1) | 110-6326 | 110-6331 | 541-6956 | 452-6006 | 265-6619 | 265-6618 | 198-8354 | 5L-3979 | 421-5479 | 4F-4097 (Quantity 2) | 117-8804 | | | 9 (2.4) | 421-1888 | 39 (10.3) | | |
| 242D3 | HSX, ME6, T7Z, T8A | | | | | | | | | | | | | | | | | | | | |
| 246D3 | KC6, PF6, T9X, T9Z | | | | | | | | | | | | | | | | 13 (3.4) | | | | |
| 262D3 | ZB2, W6E, TP3, TP4 | | | | | | | | | | | | | | | | | | | | |
| 272D3 | HX2, L32, TP9, TY3 | | | | | | | | | | | | | | | | | | | | |
| 272D3 XE | GJ2, S1L, TY4, TY6 | | | | | | | | | | | | | | | | 14 (3.7) | | | 11 (2.9) | 471-3172 |
| | | | | | | | | | | | | | | | | | 488-5278 | | | 482-8388 | |

1,000 hour cycle includes 500 hour part numbers. 1,500 hour cycle includes 500 hour part numbers. 3,000 hour planned maintenance cycle includes 1,500 and 1,000 hour part numbers.

*Closed cab machines only.

**Fluid Type

| | 500 Hour S•O•S SM Services | Interval |
|--------------------------|---------------------------------------|----------|
| Cat HYDO Advance 10 | No | 3,000 |
| | Yes | 6,000 |
| Non-Cat HYDO Advanced 10 | No | 2,000 |
| | Yes | 4,000 |

PLANNED MAINTENANCE (CONTINUED)

| COMPACT TRACK LOADER | | Initial 250 Hours | | 500 Hours | | | | | | | | 1,000 Hours | | | | | 1,500 Hours | 3,000 Hours | | |
|----------------------|--|-----------------------|-----------------------|--------------------------|-----------------------------------|-----------------|-------------------|--------------------|-----------------|--------------------------|------------------|-------------------|-----------------------|---------------------|----------|-----------------------------|----------------------|-------------|------------------|--------------------------------------|
| | | Final Drive Oil | Final Drive Oil | Engine Oil/Filter Change | | Air Filter | | Fuel Filter Change | | Lubricate Machine | Hydraulic Tank | Cabin Air* | | Cabin Air* | Engine | Hydraulic Oil/Filter Change | | | Engine Crankcase | Hydraulic Oil** |
| Sales Model | Serial Number Prefix | Oil Syn GO (1 L) | Oil Syn GO (1 L) | Filter | Oil Quantity Liter (gal) DEO-ULS™ | Primary Element | Secondary Element | In-line Element | Primary Element | Prime Application Grease | Breather Element | Fresh Air Element | Recirculating Element | A/C Compressor Belt | Belt | Filter Element | Seal (Housing) | Seal (Plug) | Breather Element | Oil Quantity Liter (gal) Hydo Adv 10 |
| 239D3 | HC9, KE9 | 350-9510 (Quantity 2) | 350-9510 (Quantity 2) | 220-1523 | 9 (2.4) | 415-2592 | 415-2593 | 541-6956 | | 452-6006 | 420-9748 | | | | 513-8590 | 421-5479 | 4F-4097 (Quantity 2) | 117-8804 | 443-0374 | 35 (9.2) |
| | K5S | | | | | 526-3118 | 526-3122 | | | | | | | | | | | | | |
| 249D3 | P9C, R9E | | | | | 415-2592 | 415-2593 | | | | | | | | | | | | | |
| | W5S | | | | | 526-3118 | 526-3122 | | | | | | | | | | | | | |
| 259D3 | CW9, TE9 | | | 377-6969 | 12 (3.1) | 110-6326 | 110-6331 | | | | 258-2829 | 265-6619 | 265-6618 | 198-8354 | 5L-3979 | 421-5479 | 4F-4097 (Quantity 2) | 117-8804 | 421-1888 | 39 (10.3) |
| 279D3 | RB9, Z9E | | | | | | | | | | | | | | | | | | | |
| 289D3 | JX9, BT9 | | | | | | | | | | | | | | | | | | | |
| 299D3 | DY9, CY9, P3R, JX3 | | | 14 (3.7) | 488-5278 | 482-8388 | 471-3172 | | | | | | | | | | | | | |
| 299D3 XE | BX9, B62, AN9, GX9, LB3, S38, R23, XES | | | | | | | | | | | | | | | | | | | |

1,000 hour cycle includes 500 hour part numbers. 1,500 hour cycle includes 500 hour part numbers. 3,000 hour planned maintenance cycle includes 1,000 and 1,500 hour part numbers.

*Closed cab machines only.

| **Fluid Type | 500 Hour S•O•S SM Services | Interval |
|--------------------------|---------------------------------------|----------|
| Cat HYDO Advance 10 | No | 3,000 |
| | Yes | 6,000 |
| Non-Cat HYDO Advanced 10 | No | 2,000 |
| | Yes | 4,000 |

| MULTI TERRAIN LOADER | | Initial 250 Hours | | 500 Hours | | | | | | | | 1,000 Hours | | | | | 1,500 Hours | 3,000 Hours | | |
|----------------------|----------------------|-----------------------|-----------------------|--------------------------|-----------------------------------|-----------------|-------------------|--------------------|-----------------|--------------------------|------------------|-------------------|-----------------------|---------------------|---------|-----------------------------|----------------------|-------------|------------------|--------------------------------------|
| | | Final Drive Oil | Final Drive Oil | Engine Oil/Filter Change | | Air Filter | | Fuel Filter Change | | Lubricate Machine | Hydraulic Tank | Cabin Air* | | Cabin Air* | Engine | Hydraulic Oil/Filter Change | | | Engine Crankcase | Hydraulic Oil** |
| Sales Model | Serial Number Prefix | Oil Syn GO (1 L) | Oil Syn GO (1 L) | Filter | Oil Quantity Liter (gal) DEO-ULS™ | Primary Element | Secondary Element | In-line Element | Primary Element | Prime Application Grease | Breather Element | Fresh Air Element | Recirculating Element | A/C Compressor Belt | Belt | Filter Element | Seal (Housing) | Seal (Plug) | Breather Element | Oil Quantity Liter (gal) Hydo Adv 10 |
| 257D3 | KEZ, 57E | 350-9510 (Quantity 2) | 350-9510 (Quantity 2) | 377-6969 | 12 (3.1) | 110-6326 | 110-6331 | 541-6956 | | 452-6006 | 258-2829 | 265-6619 | 265-6618 | 198-8354 | 5L-3979 | 421-5479 | 4F-4097 (Quantity 2) | 117-8804 | 421-1888 | 39 (10.3) |



1,000 hour cycle includes 500 hour part numbers. 1,500 hour cycle includes 500 hour part numbers. 3,000 hour planned maintenance cycle includes 1,000 and 1,500 hour part numbers.

*Closed cab machines only.

| **Fluid Type | 500 Hour S•O•S SM Services | Interval |
|--------------------------|---------------------------------------|----------|
| Cat HYDO Advance 10 | No | 3,000 |
| | Yes | 6,000 |
| Non-Cat HYDO Advanced 10 | No | 2,000 |
| | Yes | 4,000 |

RUBBER TRACK OFFERINGS **» Find the right fit for your job**

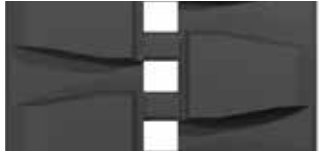
Part numbers included are for the D3 Series.

| Machine Model | | Machine Series | Track Part Number | Track Size - Width x Pitch x Lug Count mm (in) | Description |
|--|-----------|----------------------|-------------------------|--|-------------|
| <div style="display: flex; justify-content: space-around; align-items: center;"> <div style="text-align: center;">  <p>Heavy Duty Block</p> </div> <div style="text-align: center;">  <p>Heavy Duty Bar</p> </div> <div style="text-align: center;">  <p>General Duty</p> </div> </div> | | | | | |
| 239, 249 | D3 | 592-5444 | 320x86x49 (12.6x3.4x49) | 320 mm (12.6") Heavy Duty Block Track | |
| | | 561-5496 | 400x86x49 (15.7x3.4x49) | 400 mm (15.7") Heavy Duty Bar Track | |
| | | 608-7326 | 320x86x49 (12.6x3.4x49) | 320 mm (12.6") General Duty Track | |
| 259 | D3 | 592-5445 | 320x86x53 (12.6x3.4x53) | 320 mm (12.6") Heavy Duty Block Track | |
| | | 592-5827 | 400x86x53 (15.7x3.4x53) | 400 mm (15.7") Heavy Duty Block Track | |
| | | 561-5498 | 400x86x53 (15.7x3.4x53) | 400 mm (15.7") Heavy Duty Bar Track | |
| | | 584-7121 608-7327 | 320x86x53 (12.6x3.4x53) | 320 mm (12.6") General Duty Track | |
| | | 593-2029 608-7328 | 400x86x53 (15.7x3.4x53) | 400 mm (15.7") General Duty Track | |
| 279/289 | D3 | 593-1012 | 450x86x56 (17.7x3.4x56) | 450 mm (17.7") Heavy Duty Block Track | |
| | | 592-5828 | 400x86x56 (15.7x3.4x56) | 400 mm (15.7") Heavy Duty Block Track | |
| | | 584-7123 608-7329 | 450x86x56 (17.7x3.4x56) | 450 mm (17.7") General Duty Track | |
| | | 592-5441 561-5499 | 450x86x56 (17.7x3.4x56) | 450 mm (17.7") Heavy Duty Bar Track | |
| 299 | D3, D3 XE | 592-5830 | 450x86x60 (17.7x3.4x60) | 450 mm (17.7") Heavy Duty Block Track | |
| | | 592-5829 | 400x86x60 (15.7x3.4x60) | 400 mm (15.7") Heavy Duty Block Track | |
| | | 584-7124 608-7331 | 450x86x60 (17.7x3.4x60) | 450 mm (17.7") General Duty Track | |
| | | 561-5500 | 450x86x60 (17.7x3.4x60) | 450 mm (17.7") Heavy Duty Bar Track | |

| Machine Model | | Machine Series | Track Part Number | Track Size - Width x Pitch x Lug Count mm (in) | Description |
|---|----|----------------|----------------------|--|-------------|
| <div style="display: flex; justify-content: space-around; align-items: center;"> <div style="text-align: center;">  <p>General Duty</p> </div> </div> | | | | | |
| 257 | D3 | 420-9876 | 381x100x42 (15x4x42) | 381 mm (15") General Duty Track | |



FLEXPOR™ TIRES

| Machine | Size Diameter x Rubber Thickness x Tread Width | Part Number |
|--------------------------|---|---|
| 216 226 232 | 31x6x10 (10.00x16.5) | 345-7585 329-6989 Left 329-6990 Right |
| 236 246 252 262 | 33x6x11 (12.00x16.5) | 324-3427 329-6785 329-6784 Left 329-6783 Right |



TREAD OPTIONS

OTR (Off-the-road)

OTR tread design has a block pattern that provides a degree of traction in applications where debris is not an issue.

SMOOTH

Smooth tread design is ideal for special applications where debris is an issue like scrap yards, recycling centers and some waste transfer stations.

CONSTRUCTION

Construction tread design is the right choice for maximum performance in the toughest environments. It is designed for smaller machine applications where better traction is required.

UNDERCARRIAGE PARTS

| Machine Model | Series | Wheels | | Sprockets | |
|---------------|-----------|-------------|--------------------------------|-------------|-------------------------|
| | | Part Number | Description | Part Number | Description |
| 239/249 | D3 | 536-3554 | Double Flange Idler – Standard | 304-1870 | Sprocket |
| | | 536-3553 | Single Flange Idler – Standard | | |
| | | 536-3548 | Triple Flange Roller | | |
| | | 536-3555 | Triple Flange Idler | | |
| | | | | | |
| 257 | D3 | 305-9270 | Steel Rear Idler | 342-5015 | Outer Sleeve (Hardened) |
| | | | | 342-5014 | Inner Sleeve (Hardened) |
| | | 278-1301 | Front Idler | 258-3087 | Sprocket Ring |
| | | | | 280-5091 | Sprocket Bolt |
| | | 295-3250 | Front Idler (Steel)* | 7X-3392 | Washer |
| | | 278-1261 | Bogie Wheel | 1K-6872 | Locknut |
| 259 | D3 | 536-3551 | Double Flange Idler | 304-1870 | Sprocket (Standard) |
| | | 536-3550 | Single Flange Idler | 601-3153 | Sprocket (Hardened) |
| | | 536-3549 | Triple Flange Roller | | |
| | | 536-3552 | Triple Flange Idler | | |
| 279/289/299 | D3, D3 XE | 536-3551 | Double Flange Idler | 304-1916 | Sprocket (Standard) |
| | | 536-3550 | Single Flange Idler | 601-3160 | Sprocket (Hardened) |
| | | 536-3549 | Triple Flange Roller | | |
| | | 536-3552 | Triple Flange Idler | | |

*Optional offerings available for abrasive applications

COMMON GROUND ENGAGING TOOLS BROOM EDGES AND ACCESSORIES

| Part Type | Model | Part Number |
|--|---------------------------|-------------|
| Bolt-On Cutting Edge | BU115, BU115B | 489-6702 |
| Bolt-On Cutting Edge | BU115, BU115B | 489-6703 |
| Bolt-On Cutting Edge | BP115C | 452-4148 |
| Bolt-On Cutting Edge | BP118C | 452-4147 |
| Poly Bristle Assemblies (Quantity 18) | BU115, BP115B, BP115C | 165-9069 |
| Wire Bristle Assemblies (Quantity 17) | BU115, BP115B, BP115C | 165-9070 |
| Poly Bristle Assemblies (Quantity 21) | BU118, BP118B, BP118C | 165-9071 |
| Wire Bristle Assemblies (Quantity 20) | BU118, BP118B, BP118C | 165-9072 |
| Poly Bristle Assemblies (Quantity 22) | BA118, BA118C | 166-0322 |
| Wire Bristle Assemblies (Quantity 21) | BA118, BA118C | 166-0323 |
| Wire Bristle Assemblies (Gutter Brush) | All series gutter brushes | 172-4563 |
| Poly Bristle Assemblies (Gutter Brush) | All series gutter brushes | 460-9777 |

COMMON GROUND ENGAGING TOOLS (CONTINUED) BUCKET TOOTHBARS, TEETH AND CUTTING EDGES

| Part Type | Bucket Size | Bucket Type | Part Description | Part Number |
|-----------------------|--|--|---------------------------------|-------------|
| Bolt-On Tooth Bar | 1883 mm (74 inch) | General Purpose / Multi-Purpose – Base Edge Buckets | 8 Teeth | 136-8736 |
| | 2036 mm (80 inch) | General Purpose / Multi-Purpose – Base Edge Buckets | 8 Teeth | 217-4878 |
| | 2188 mm (86 inch) | General Purpose / Multi-Purpose – Base Edge Buckets | 8 Teeth | 275-5427 |
| | 1576 mm (62 inch) | General Purpose / Multi-Purpose – Bolt-On Edge Buckets | 7 Teeth | 159-0330 |
| | 1730 mm (68 inch) | General Purpose / Multi-Purpose – Bolt-On Edge Buckets | 8 Teeth | 159-0340 |
| | 1883 mm (74 inch) | General Purpose / Multi-Purpose – Bolt-On Edge Buckets | 8 Teeth | 159-0350 |
| | 2036 mm (80 inch) | General Purpose / Multi-Purpose – Bolt-On Edge Buckets | 8 Teeth | 195-9160 |
| | 2188 mm (86 inch) | General Purpose / Multi-Purpose – Bolt-On Edge Buckets | 8 Teeth | 264-2084 |
| Serrated Cutting Edge | 1576 mm (62 inch) | General Purpose / Multi-Purpose – Base Edge Buckets | – | 319-9599 |
| | 1730 mm (68 inch) | General Purpose / Multi-Purpose – Base Edge Buckets | – | 319-9600 |
| | 1883 mm (74 inch) | General Purpose / Multi-Purpose – Base Edge Buckets | – | 319-9601 |
| | 2036 mm (80 inch) | General Purpose / Multi-Purpose – Base Edge Buckets | – | 319-9602 |
| | 2188 mm (86 inch) | General Purpose / Multi-Purpose – Base Edge Buckets | – | 319-9603 |
| Bolt-On Cutting Edge | 1421 mm (56 inch) | Low Profile Buckets | 152.4mm width, 12.7mm thickness | 135-9393 |
| | 1421 mm (56 inch) | Low Profile Buckets | 203mm width, 16mm thickness | 174-7965 |
| | 1421 mm (56 inch) | Low Profile Buckets | 203mm width, 19mm thickness | 174-7971 |
| | 1576 mm (62 inch) | General Purpose / Multi-Purpose / Low Profile / Utility / Grapple Buckets | 165mm width, 16mm thickness | 135-9394 |
| | 1576 mm (62 inch) | General Purpose / Multi-Purpose / Low Profile / Utility / Grapple Buckets | 203mm width, 16mm thickness | 174-7966 |
| | 1576 mm (62 inch) | General Purpose / Multi-Purpose / Low Profile / Utility / Grapple Buckets | 203mm width, 19mm thickness | 174-7972 |
| | 1730 mm (68 inch) | General Purpose / Multi-Purpose / Low Profile / Utility / Grapple Buckets | 165mm width, 16mm thickness | 135-9395 |
| | 1730 mm (68 inch) | General Purpose / Multi-Purpose / Low Profile / Utility / Grapple Buckets | 203mm width, 16mm thickness | 174-7967 |
| | 1730 mm (68 inch) | General Purpose / Multi-Purpose / Low Profile / Utility / Grapple Buckets | 203mm width, 19mm thickness | 174-7973 |
| | 1883 mm (74 inch) | General Purpose / Multi-Purpose / Low Profile / Utility / Grapple / Light Material Buckets | 165mm width, 16mm thickness | 135-9396 |
| | 1883 mm (74 inch) | General Purpose / Multi-Purpose / Low Profile / Utility / Grapple / Light Material Buckets | 203mm width, 16mm thickness | 174-7968 |
| | 1883 mm (74 inch) | General Purpose / Multi-Purpose / Low Profile / Utility / Grapple / Light Material Buckets | 203mm width, 19mm thickness | 174-7974 |
| | 2036 mm (80 inch) | General Purpose / Multi-Purpose / Low Profile / Light Material / Grapple Buckets | 165mm width, 16mm thickness | 135-9397 |
| | 2036 mm (80 inch) | General Purpose / Multi-Purpose / Low Profile / Light Material / Grapple Buckets | 203mm width, 16mm thickness | 174-7969 |
| | 2036 mm (80 inch) | General Purpose / Multi-Purpose / Low Profile / Light Material / Grapple Buckets | 203mm width, 19mm thickness | 174-7975 |
| | 2188 mm (86 inch) | General Purpose / Multi-Purpose / Light Material Buckets / Material Handling | 165mm width, 16mm thickness | 195-5124 |
| | 2188 mm (86 inch) | General Purpose / Multi-Purpose / Light Material Buckets / Material Handling | 203mm width, 16mm thickness | 174-7970 |
| | 2188 mm (86 inch) | General Purpose / Multi-Purpose / Light Material Buckets / Material Handling | 203mm width, 19mm thickness | 174-7976 |
| | 2490 mm (98 inch) | Light Material Buckets / Material Handling | 165mm width, 16mm thickness | 296-7602 |
| | 2642 mm (104 inch) | Material Handling | 165mm width, 16mm thickness | 469-4306 |
| Unitooth | General Purpose / Multi-Purpose Buckets with Bolt-On Teeth | – | 132-4720 | |

COMMON GROUND ENGAGING TOOLS (CONTINUED)

AUGER BITS AND ACCESSORIES

| Part Class | Type / Size | Part Number |
|------------------------|--------------------------------------|------------------------------|
| Standard Duty Bits | 102 mm (4 inch) | 366-7751 |
| | 152 mm (6 inch) | 153-4083 |
| | 229 mm (9 inch) | 153-4084 |
| | 305 mm (12 inch) | 153-4085 |
| | 381 mm (15 inch) | 366-7752 |
| | 457 mm (18 inch) | 153-4086 |
| | 610 mm (24 inch) | 153-4089 |
| | 762 mm (30 inch) | 217-3194 |
| | 457 mm (36 inch) | 153-4091 |
| Industrial Duty Bits | 152 mm (6 inch) | 372-0260 |
| | 229 mm (9 inch) | 372-0261 |
| | 305 mm (12 inch) | 372-0262 |
| | 406 mm (16 inch) | 372-0263 |
| | 457 mm (18 inch) | 372-0264 |
| | 610 mm (24 inch) | 372-0265 |
| | 762 mm (30 inch) | 372-0266 |
| | 457 mm (36 inch) | 372-0267 |
| | 1067 mm (42 inch) | 372-0268 |
| 1219 mm (48 inch) | 372-0269 | |
| Industrial Rock Bits | 152 mm (6 inch) | 372-0270 |
| | 229 mm (9 inch) | 372-0271 |
| | 305 mm (12 inch) | 372-0272 |
| | 406 mm (16 inch) | 372-0273 |
| | 457 mm (18 inch) | 372-0274 |
| | 508 mm (20 inch) | 372-0275 |
| | 610 mm (24 inch) | 372-0276 |
| | 762 mm (30 inch) | 372-0277 |
| | 457 mm (36 inch) | 372-0278 |
| | Rock Drill Head Tooth | 372-0289 |
| Teeth | Gage Tooth (Outer) | 371-3694 |
| | Flat Tooth (Inner) | 371-3690 |
| | HF Gage Tooth (Outer) | 371-3695 |
| | Flat Carbide Tooth (Inner) | 371-3691 |
| | Chisel Tooth (Inner) | 371-3696 |
| | Flat Hard Face Tooth HF (Inner) | 371-3692 |
| | Chisel Carbide Tooth (Inner) | 371-3697 |
| | Flat HF Tooth (HF Both Sides, Inner) | 371-3693 |
| | Chisel HF Tooth (Inner) | 371-3698 |
| | Standard Duty Tooth | 153-4094 |
| | Hard Face Tooth | 174-9566 |
| | Carbide Inserted Tooth | 174-9567 |
| Tree Bits | 610 mm (24 inch) | 153-4092 |
| | 457 mm (36 inch) | 153-4095 |
| | 152 mm (6 inch) Bolt-On | 372-0230 |
| Rock Heads* | 229 mm (9 inch) Bolt-On | 372-0231 |
| | 305 mm (12 inch) Bolt-On | 372-0232 |
| | 381 mm (15 inch) Bolt-On | 372-0233 |
| | 457 mm (18 inch) Bolt-On | 372-0234 |
| | 610 mm (24 inch) Bolt-On | 372-0235 |
| Part Class (Continued) | Type / Size (Continued) | Part Number (Continued) |
| | Adapters | Hex to Round Round to Hex |
| Extensions | 305 mm (12 inch) | 156-6328 |
| | 610 mm (24 inch) | 217-3192 |
| Telescoping Extensions | 0.91 meter (3 feet) | 372-0256 |
| | 1.83 meters (6 feet) | 372-0257 |
| Accessories | Retention Pin Kit | 372-0258 |
| | Pilot Point | 153-4093 |
| | Pilot Point – Industrial Rock | 367-9767 |



BATTERIES

| Model | Voltage | Part Number |
|------------------|----------|-------------|
| Standard Battery | 850 CCA | 230-6368 |
| Heavy Duty | 1000 CCA | 115-2422 |



ENGINE PARTS

| Machine Model | Notes | Starter Motor | Alternator | Water Pump | Turbocharger |
|---|-----------------------|---------------|------------|------------|--------------|
| 226D3 (DX8, D5R), 239D3 (HC9, KE9), 232D3(HRS, D5Z), 249D3 (P9C, R9E) | U.S. EPA Tier 4 Final | 461-8764 | 490-0056 | 523-4432 | 480-4349 |
| 226D3 (EK5), 239D3 (K5S), 232D3 (GJ5), 249D3 (WS5) | EU Stage 5 | | | 569-8588 | 581-4037 |
| 236D3, 242D3, 246D3, 257D3, 259D3, 262D3, 279D3, 289D3 | Tier 4 Final | 385-5044 | 397-9953 | 387-9903 | 436-1920 |
| | Stage 5 | | | | |
| 272D3, 299D3 | Tier 4 Final/Stage V | 377-6967 | 377-6966 | 389-5309 | 482-8480 |
| 272D3 XE, 299D3 XE | | | | | |

CAB GLASS

| Part Description | Part Number | Quantity |
|---|-------------|----------|
| Rearview Mirror | 345-6131 | 1 |
| Window – Polycarbonate Door (for flying debris) | 418-5850 | 1 |
| Window – Glass Door (general use) | 345-6230 | 1 |
| Window Assembly – Sliding Upper Front Panel (Left) | 345-6271 | 1 |
| Window Assembly – Sliding Upper Front Panel (Right) | 345-6274 | 1 |
| Window Assembly – Sliding Upper Rear Panel (Left) | 345-6270 | 1 |
| Window Assembly – Sliding Upper Rear Panel (Right) | 345-6275 | 1 |
| Window Latch Assembly – (Left or Right) | 258-3765 | 2 |
| Window Assembly – Fixed Lower Panel (Left) | 345-6273 | 1 |
| Window Assembly – Fixed Lower Panel (Right) | 345-6276 | 1 |
| Window Pad – For Lower Glass (Left or Right) | 435-8783 | 2 |
| Window – Rear | 345-6011 | 1 |
| Window – Top | 258-4012 | 1 |



*For use with standard bits only

LIGHTS

| Lamp Type | Part Number | Quantity |
|--------------------------------|-------------|----------|
| Dome | 210-8754 | 1 |
| Flood – Front and Rear Working | 9W-0607 | 4 |
| Headlight (Roading) | 9W-3324 | 2 |
| Front Turn Signal (Roading) | 226-4561 | 2 |
| Front Position (Roading) | 226-4560 | 2 |
| Rear Turn Signal (Roading) | 9W-3326 | 2 |
| Stop and Tail (Roading) | 084-4348 | 2 |
| License Plate Holder (Roading) | 195-9712 | 1 |
| Warning Beacon | 9X-8118 | 1 |
| LED Kit – 2 Front and 2 Rear | 499-2684 | 1 |



QUICK DISCONNECTS

Get the most out of your Cat D3 Series Skid Steer, Compact Track, or Multi Terrain Loader with a wide range of hydraulic work tool attachments that can be easily interchanged with Quick Disconnects. **Contact your Cat dealer for a complete list of all available attachments.**

| Model | Part Number | | | | |
|---------------------------------|-------------|-------------|-----------|-------------|-----------------|
| | Male 1/2" | Female 1/2" | Male 3/4" | Female 3/4" | Case Drain 3/8" |
| Standard Flow/High Flow | 373-6967 | 373-6968 | – | – | – |
| D3 XE Models | 550-0926 | 550-0927 | 550-0924 | 550-0923 | 550-0925 |
| Land Management – D3 XE Models* | 550-0926 | 550-0927 | 550-0921* | 550-0922* | 550-0925 |

*Screw to connect auxiliary Quick Disconnects



Vertical Lift Linkage

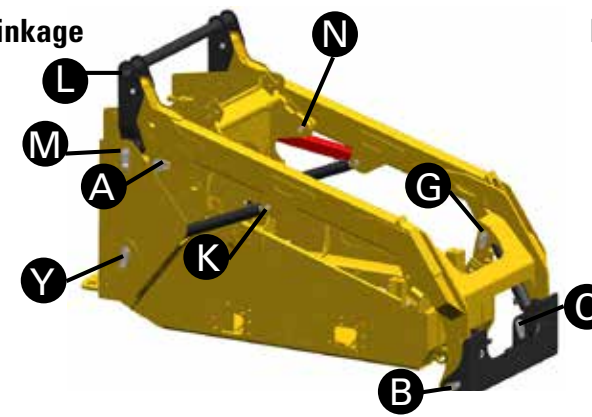

Radial Lift Linkage

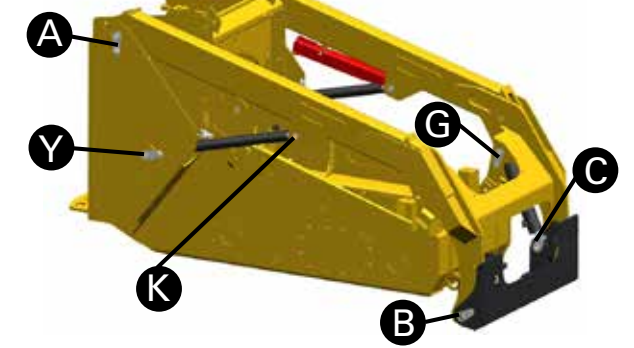

SKID STEER LOADER (SSL) LINKAGE PIN DATA

| SSL Linkage Pin | | Vertical Lift Linkage | | | | | | | | |
|-----------------|----------------------|------------------------------------|------------------------------------|------------------------------------|------------------------------------|------------------------------------|-------------------------------------|------------------------------------|-------------------------------------|------------------------------------|
| Sales Model | Serial Number Prefix | A | B | C | G | K | L | M | N | Y |
| 232D3 | HRS, D5Z, GJ5 | 435-8809 Pin Assembly (Quantity 2) | 345-6511 Pin Assembly (Quantity 2) | 435-8795 Pin Assembly (Quantity 2) | 435-8806 Pin Assembly (Quantity 2) | 258-3451 Pin Assembly (Quantity 2) | 435-8808 Pin Assembly (Quantity 2) | 388-7780 Pin Assembly (Quantity 2) | 472-6927 Link Assembly (Quantity 2) | 435-8793 Pin Assembly (Quantity 2) |
| 242D3 | HSX, ME6, T7Z, T8A | 452-0480 Pin Assembly (Quantity 2) | | 388-7776 Pin Assembly (Quantity 2) | 388-7770 Pin Assembly (Quantity 2) | | 422-3184 Link Assembly (Quantity 2) | 388-8291 Pin Assembly (Quantity 2) | | |
| 262D3 | ZB2, W6E, TP3, TP4 | 568-4601 Pin Assembly (Quantity 2) | | 142-9091 Pin Assembly (Quantity 2) | 258-2679 Pin Assembly (Quantity 2) | | 568-4603 Link Assembly (Quantity 2) | 487-0045 Pin Assembly (Quantity 2) | | |
| 272D3 | HX2, L32, TP9, TY3 | 568-4602 Pin Assembly (Quantity 2) | | 345-5982 Pin (Quantity 2) | 345-5909 Pin Assembly (Quantity 2) | | 512-3513 Link Assembly (Quantity 2) | | | |
| 272D3 XE | GJ2, S1L, TY4, TY6 | | | | | | | | | |

| SSL Linkage Pin | | Radial Lift Linkage | | | | | |
|-----------------|----------------------|------------------------------------|------------------------------------|------------------------------------|------------------------------------|---------------------------|------------------------------------|
| Sales Model | Serial Number Prefix | A | B | C | G | K | Y |
| 226D3 | DX8, D5R, EK5 | 388-7780 Pin Assembly (Quantity 2) | 345-6511 Pin Assembly (Quantity 2) | 435-8795 Pin Assembly (Quantity 2) | 435-8806 Pin (Quantity 2) | 258-3451 Pin (Quantity 2) | 435-8793 Pin Assembly (Quantity 2) |
| 236D3 | KXL, GK6 | | | 142-9091 Pin Assembly (Quantity 2) | 388-7776 Pin Assembly (Quantity 2) | | 388-8291 Pin Assembly (Quantity 2) |
| 246D3 | KC6, PF6, T9X, T9Z | | | 345-5909 Pin Assembly (Quantity 2) | 258-2679 Pin Assembly (Quantity 2) | | 493-0196 Pin Assembly (Quantity 2) |

| SSL Bearings | | Vertical Lift Linkage | | | |
|--------------|----------------------|-------------------------------|------------------------------|-------------------------------|------------------------------|
| Sales Model | Serial Number Prefix | A | B | L | M |
| 232D3 | HRS, D5Z, GJ5 | 191-9633 Bushing (Quantity 4) | 6K-4148 Bushing (Quantity 4) | 142-8805 Bushing (Quantity 4) | 6K-4148 Bushing (Quantity 4) |
| 242D3 | HSX, ME6, T7Z, T8A | | | 4K-4709 Bushing (Quantity 4) | 4K-4709 Bushing (Quantity 4) |
| 262D3 | ZB2, W6E, TP3, TP4 | | | | |
| 272D3 | HX2, L32 | | | 9R-0430 Bushing (Quantity 4) | |
| 272D3 XE | GJ2, S1L | | | | |

| SSL Bearings | | Radial Lift Linkage | |
|--------------|----------------------|------------------------------|------------------------------|
| Sales Model | Serial Number Prefix | A | B |
| 226D3 | DX8, D5R, EK5 | 6K-4148 Bushing (Quantity 4) | 6K-4148 Bushing (Quantity 4) |
| 236D3 | KXL, GK6 | | |
| 246D3 | KC6, PF6, T9X, T9Z | | |

| SSL Grease Fittings | | Vertical Lift Linkage | | | | | | | | |
|---------------------|----------------------|-------------------------------------|-------------------------------------|-------------------------------------|-------------------------------------|-------------------------------------|---------------------------------------|---------------------------------------|-------------------------------------|---|
| Sales Model | Serial Number Prefix | B | C | G | K | L | M | N | | |
| 232D3 | HRS, D5Z, GJ5 | 3B-8489 Grease Fitting (Quantity 2) | 3B-8489 Grease Fitting (Quantity 2) | - | 3B-8489 Grease Fitting (Quantity 2) | 5B-0651 Grease Fitting (Quantity 2) | 5B-0651 Straight Fitting (Quantity 2) | 3B-8489 Grease Fitting (Quantity 2) | | |
| 242D3 | HSX, ME6, T7Z, T8A | | | 3B-8489 Grease Fitting (Quantity 2) | | 3B-8489 Grease Fitting (Quantity 2) | | 5B-0651 Straight Fitting (Quantity 2) | 3B-8489 Grease Fitting (Quantity 2) | - |
| 262D3 | ZB2, W6E, TP3, TP4 | | | | | | | | | |
| 272D3 | HX2, L32, TP9, TY3 | | | | | | | | | |
| 272D3 XE | GJ2, S1L, TY4, TY6 | | | | | | | | | |

| SSL Grease Fittings | | Radial Lift Linkage | | | | | |
|---------------------|----------------------|---------------------------------------|-------------------------------------|-------------------------------------|-------------------------------------|-------------------------------------|--|
| Sales Model | Serial Number Prefix | A | B | C | G | K | |
| 226D3 | DX8, D5R, EK5 | 5B-0651 Straight Fitting (Quantity 2) | 3B-8489 Grease Fitting (Quantity 2) | 3B-8489 Grease Fitting (Quantity 2) | - | 3B-8489 Grease Fitting (Quantity 2) | |
| 236D3 | KXL, GK6 | | | | 3B-8489 Grease Fitting (Quantity 2) | | |
| 246D3 | KC6, PF6, T9X, T9Z | | | | | | |

| SSL Retention Hardware | | Vertical Lift Linkage | | | | | | | | | |
|------------------------|----------------------|---------------------------------------|---|---|---|-------------------------------------|-------------------------------------|-------------------------------------|-------------------------------------|------------------------------|---------------------------------|
| Sales Model | Serial Number Prefix | A | B | C | G | K | L | M | N | Y | |
| 232D3 | HRS, D5Z, GJ5 | 119-4594 Washer (Quantity 8) | 523-0657 Bolt (Quantity 2) | 8T-4222 Washer (Quantity 2) | 4S-5875 Retaining Ring (Quantity 2) | 1H-8134 Retaining Ring (Quantity 4) | 523-0657 Bolt (Quantity 2) | 7X-7729 Washer (Quantity 2) | 1M-7914 Retaining Ring (Quantity 2) | 308-6542 Spacer (Quantity 2) | |
| | | 191-9738 Washer (Quantity 2) | | | 6V-7744 Locknut (Quantity 2) | | | | | 481-3999 Washer (Quantity 2) | |
| | | 550-6670 Flat Head Screw (Quantity 2) | | | 8T-4198 Bolt (Quantity 2) | | | | | 523-0657 Bolt (Quantity 2) | |
| 242D3 | HSX, ME6, T7Z, T8A | 119-4594 Washer (Quantity 10) | 523-0657 Bolt (Quantity 2) | 8T-4222 Washer (Quantity 2) | 363-2855 Shim (Left Side only) (Quantity 5) | 1H-8134 Retaining Ring (Quantity 4) | 4M-5285 Retaining Ring (Quantity 4) | 523-0657 Bolt (Quantity 2) | 388-7774 Spacer (Quantity 2) | 142-9142 Spacer (Quantity 2) | |
| | | 191-9738 Washer (Quantity 2) | | | 8T-4222 Washer (Quantity 2) | | | | | 8T-5439 Washer (Quantity 2) | 7X-7729 Washer (Quantity 2) |
| | | 550-6670 Flat Head Screw (Quantity 2) | | | 523-0657 Bolt (Quantity 2) | | | | | 523-0657 Bolt (Quantity 2) | 523-0657 Bolt (Quantity 2) |
| 262D3 | ZB2, W6E, TP3, TP4 | 568-4607 Plate (Quantity 2) | 523-0658 Bolt (Quantity 2) | 8T-4222 Washer (Quantity 2) | 3B-4634 Cotter Pin (Quantity 2) | 1H-8134 Retaining Ring (Quantity 4) | 6V-7700 Retaining Ring (Quantity 4) | 512-3523 Washer (Quantity 2) | 4S-5875 Retaining Ring (Quantity 2) | 435-8772 Spacer (Quantity 2) | |
| | | 550-0805 Hex Slotted Nut (Quantity 2) | | | | | | | | 8T-4222 Washer (Quantity 2) | 523-0657 Bolt (Quantity 2) |
| 272D3 | HX2, L32, TP9, TY3 | 287-4215 Washer (Quantity 2) | 3S-8536 Spacer (Quantity 2) | 363-2855 Shim (Left Side only) (Quantity 5) | 3B-4634 Cotter Pin (Quantity 2) | 1H-8134 Retaining Ring (Quantity 4) | 6V-7700 Retaining Ring (Quantity 4) | 4S-5875 Retaining Ring (Quantity 2) | 8T-4222 Washer (Quantity 2) | 8T-4222 Washer (Quantity 2) | |
| 272D3 XE | GJ2, S1L, TY4, TY6 | 568-4607 Plate (Quantity 2) | 363-2855 Shim (Left Side only) (Quantity 5) | | | | | | | 550-0805 Nut (Quantity 2) | 3B-4634 Cotter Pin (Quantity 2) |

| SSL Retention Hardware | | Radial Lift Linkage | | | | | | |
|------------------------|----------------------|------------------------------|---|------------------------------|-------------------------------------|-------------------------------------|------------------------------|------------------------------|
| Sales Model | Serial Number Prefix | A | B | C | G | K | L | Y |
| 226D3 | DX8, D5R, EK5 | 523-0657 Bolt (Quantity 2) | 523-0657 Bolt (Quantity 2) | 523-0657 Bolt (Quantity 2) | 4S-5875 Retaining Ring (Quantity 2) | 1H-8134 Retaining Ring (Quantity 4) | 308-6542 Spacer (Quantity 2) | 308-6542 Spacer (Quantity 2) |
| 236D3 | KXL, GK6 | | | | 6V-7744 Locknut (Quantity 2) | | 481-3999 Washer (Quantity 2) | 481-3999 Washer (Quantity 2) |
| | | | | | 8T-4198 Bolt (Quantity 2) | | 9R-0158 Washer (Quantity 4) | 523-0657 Bolt (Quantity 2) |
| 246D3 | KC6, PF6, T9X, T9Z | 481-3999 Washer (Quantity 2) | 363-2855 Shim (Left Side only) (Quantity 5) | 8T-4222 Washer (Quantity 2) | 523-0657 Bolt (Quantity 2) | 1H-8134 Retaining Ring (Quantity 4) | 8T-4222 Washer (Quantity 2) | 8T-4222 Washer (Quantity 2) |
| | | 523-0657 Bolt (Quantity 2) | 8T-4222 Washer (Quantity 2) | 345-5429 Spacer (Quantity 2) | 523-0657 Bolt (Quantity 2) | | 523-0657 Bolt (Quantity 2) | |
| | | 8T-4222 Washer (Quantity 2) | 345-5429 Spacer (Quantity 2) | 523-0657 Bolt (Quantity 2) | 523-0657 Bolt (Quantity 2) | | 523-0657 Bolt (Quantity 2) | |

COMPACT TRACK LOADER (CTL) LINKAGE PIN DATA

| CTL Linkage Pin | | Vertical Lift Linkage | | | | | | | | |
|-----------------|--|------------------------------------|------------------------------------|------------------------------------|------------------------------------|------------------------------------|-------------------------------------|-------------------------------------|-------------------------------------|------------------------------------|
| Sales Model | Serial Number Prefix | A | B | C | G | K | L | M | N | Y |
| 249D3 | P9C, R9E, WS5 | 435-8809 Pin Assembly (Quantity 2) | 345-6511 Pin Assembly (Quantity 2) | 435-8795 Pin Assembly (Quantity 2) | 435-8806 Pin Assembly (Quantity 2) | 258-3451 Pin Assembly (Quantity 2) | 435-8808 Pin Assembly (Quantity 2) | 388-7770 Pin Assembly (Quantity 2) | 472-6927 Link Assembly (Quantity 2) | 435-8793 Pin Assembly (Quantity 2) |
| 259D3 | CW9, TE9 | 452-0480 Pin Assembly (Quantity 2) | | 388-7776 Pin Assembly (Quantity 2) | 388-7770 Pin Assembly (Quantity 2) | | 388-7780 Pin Assembly (Quantity 2) | 422-3184 Link Assembly (Quantity 2) | 388-8291 Pin Assembly (Quantity 2) | |
| 289D3 | JX9, BT9 | 568-4601 Pin Assembly (Quantity 2) | | 142-9091 Pin Assembly (Quantity 2) | 258-2679 Pin Assembly (Quantity 2) | | 345-5982 Pin (Quantity 2) | 345-5909 Pin Assembly (Quantity 2) | 568-4603 Link Assembly (Quantity 2) | 487-0045 Pin Assembly (Quantity 2) |
| 299D3 | DY9, CY9, P3R, JX3 | 568-4602 Pin Assembly (Quantity 2) | | 345-5982 Pin (Quantity 2) | 345-5909 Pin Assembly (Quantity 2) | | 512-3513 Link Assembly (Quantity 2) | | | |
| 299D3 XE | BX9, AN9, LB3, XES, B62, GX9, S38, R23 | 568-4602 Pin Assembly (Quantity 2) | | 345-5982 Pin (Quantity 2) | 345-5909 Pin Assembly (Quantity 2) | | 512-3513 Link Assembly (Quantity 2) | | | |

| CTL Linkage Pin | | Radial Lift Linkage | | | | | |
|-----------------|----------------------|------------------------------------|------------------------------------|------------------------------------|------------------------------------|------------------------------------|------------------------------------|
| Sales Model | Serial Number Prefix | A | B | C | G | K | Y |
| 239D3 | HC9, KE9, K5S | 388-7780 Pin Assembly (Quantity 2) | 345-6511 Pin Assembly (Quantity 2) | 435-8795 Pin Assembly (Quantity 2) | 435-8806 Pin (Quantity 2) | 258-3451 Pin Assembly (Quantity 2) | 435-8793 Pin Assembly (Quantity 2) |
| 279D3 | RB9, Z9E | 345-5909 Pin Assembly (Quantity 2) | | 142-9091 Pin Assembly (Quantity 2) | 258-2679 Pin Assembly (Quantity 2) | | 493-0196 Pin Assembly (Quantity 2) |

MULTI TERRAIN LOADER (MTL) LINKAGE PIN DATA

| MTL Linkage Pin | | Vertical Lift Linkage | | | | | | | | |
|------------------------|----------------------|---|---|---|--|--|--|--|--|--|
| Sales Model | Serial Number Prefix | A | B | C | G | K | L | M | N | |
| 257D3 | KEZ, S7E | 452-0480 Pin Assembly (Quantity 2) | 345-6511 Pin Assembly (Quantity 2) | 142-9091 Pin Assembly (Quantity 2) | 388-7776 Pin Assembly (Quantity 2) | 258-3451 Pin (Quantity 2) | 388-7770 Pin Assembly (Quantity 2) | 388-7780 Pin Assembly (Quantity 2) | 422-3184 Link Assembly (Quantity 2) | |
| MTL Bearings | | Vertical Lift Linkage | | | | | | | | |
| Sales Model | Serial Number Prefix | A | B | C | G | K | L | M | N | Y |
| 257D3 | KEZ, S7E | 191-9633 Bushing (Quantity 4) | 6K-4148 Bushing (Quantity 4) | - | - | - | 142-8805 Bushing (Quantity 4) | 6K-4148 Bushing (Quantity 4) | - | - |
| MTL Grease Fittings | | Vertical Lift Linkage | | | | | | | | |
| Sales Model | Serial Number Prefix | A | B | C | G | K | L | M | N | Y |
| 257D3 | KEZ, S7E | - | 3B-8489 Grease Fitting (Quantity 2) | 3B-8489 Grease Fitting (Quantity 2) | - | 3B-8489 Grease Fitting (Quantity 2) | 3B-8489 Grease Fitting (Quantity 2) | 5B-0651 Straight Fitting (Quantity 2) | - | - |
| MTL Retention Hardware | | Vertical Lift Linkage | | | | | | | | |
| Sales Model | Serial Number Prefix | A | B | C | G | K | L | M | N | Y |
| 257D3 | KEZ, S7E | 119-4594 Washer (Quantity 10) 191-9738 Washer (Quantity 2) 550-6670 Flat Head Screw (Quantity 2) 481-3999 Washer (Quantity 2) 523-0657 Bolt (Quantity 2) 435-8888 Spacer (Quantity 2) | 523-0657 Bolt (Quantity 2) 8T-4222 Washer (Quantity 2) 363-2855 Shim (Left Side only) (Quantity 5) | 523-0657 Bolt (Quantity 2) 8T-4222 Washer (Quantity 2) | 523-0657 Bolt (Quantity 2) 8T-4222 Washer (Quantity 2) | 1H-8134 Retaining Ring (Quantity 4) | 4M-5285 Retaining Ring (Quantity 4) | 481-3999 Washer (Quantity 2) 523-0657 Bolt (Quantity 2) | 2K-5964 Retaining Ring (Quantity 2) 388-7774 Spacer (Quantity 2) | 142-9142 Spacer (Quantity 2) 8T-5439 Washer (Quantity 2) 7X-7729 Washer (Quantity 2) 523-0657 Bolt (Quantity 2) |

LET'S DO THE WORK.™

PEDJ0859
(Am North, EU, APD, ANZP)
October 2021

© 2021 Caterpillar. All Rights Reserved. CAT, CATERPILLAR, LET'S DO THE WORK, their respective logos, "Caterpillar Yellow," the "Power Edge" and Cat "Modern Hex" trade dress, as well as corporate and product identity used herein, are trademarks of Caterpillar and may not be used without permission.

