

CAT® C3.6

CHINA NONROAD STAGE IV

74.4-82 KW (100-110 HP)

INDUSTRIAL ENGINE



The Cat® C3.6 engines offer a compact power solution for off-highway applications in construction and industrial. These compact, 4 cylinder engines provide excellent performance in power, peak and low speed torque, fuel consumption and transient response.



FEATURES AND BENEFITS

INSTALLATION

Smaller in size than its predecessor, the Cat C3.6 is a powerful engine in a compact and easily integrated size that saves OEMs valuable time and costs. With flexible aftertreatment mounting options and a simplified engine installation process, the C3.6 can be placed into a wide variety of applications with agility and speed.

TOTAL COST OF OWNERSHIP

Owning and operating equipment is a big investment, so it only makes sense to get the most you can from it. Thanks to the chosen technologies of the Cat C3.6, owners can experience an overall savings in fluid.

GLOBAL CAT® DEALER PRODUCT SUPPORT

World-class product support offered through a superior dealer service network, Customer Support Agreements (CSA) and Extended Service Coverage (ESC)

SPECIFICATION

Cylinders	4
Displacement, litres (in ³)	3.6
Aspiration	Turbocharged aftercooled
Bore and stroke, mm (in)	98 x 120 (3.9 x 4.7)
Maximum power, kW (hp)	82 (110)
Rated speed, rpm	2200
Maximum torque, Nm (lb ft) @ rpm	450 (331.7) @ 1500
Combustion system	Direct injection
Weight, kg (lb)	380 (839)
Rotation (viewed from flywheel)	Counterclockwise

For additional information on all your power requirements, visit www.cat-industrial.com

All information in this document is substantially correct at time of printing and may be altered subsequently. Photographs are for illustrative purposes only and may not reflect final specification. Final weight and dimensions will depend on completed specification. Information subject to selected configuration, and subject to change without notice. Engine power measured per ISO 14396:2002

AEXJ0115-01 (01-22)

© 2022 Caterpillar. All Rights Reserved. CAT, CATERPILLAR, LET'S DO THE WORK, their respective logos, "Caterpillar Corporate Yellow", the "Power Edge" and Cat "Modern Hex" trade dress as well as corporate and product identity used herein, are trademarks of Caterpillar and may not be used without permission.

CAT® C3.6

CHINA NONROAD STAGE IV

74.4-82 KW (100-110 HP)



INDUSTRIAL ENGINE

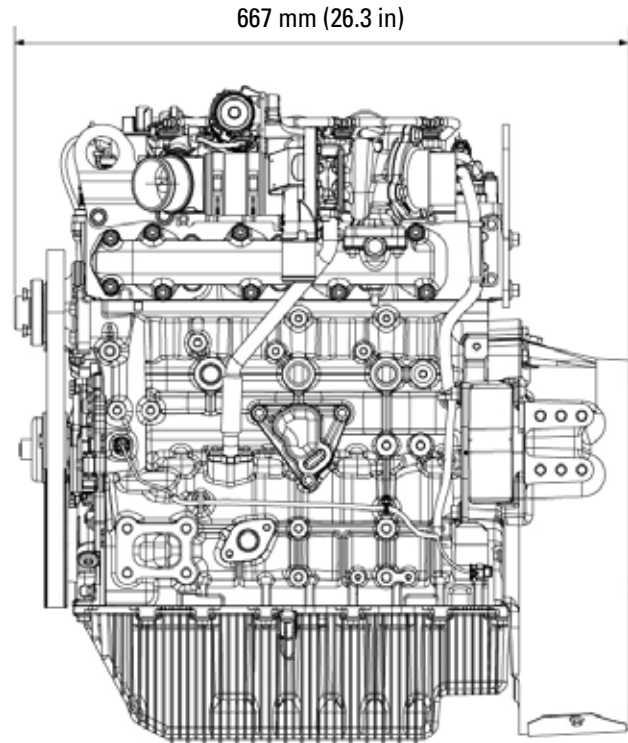
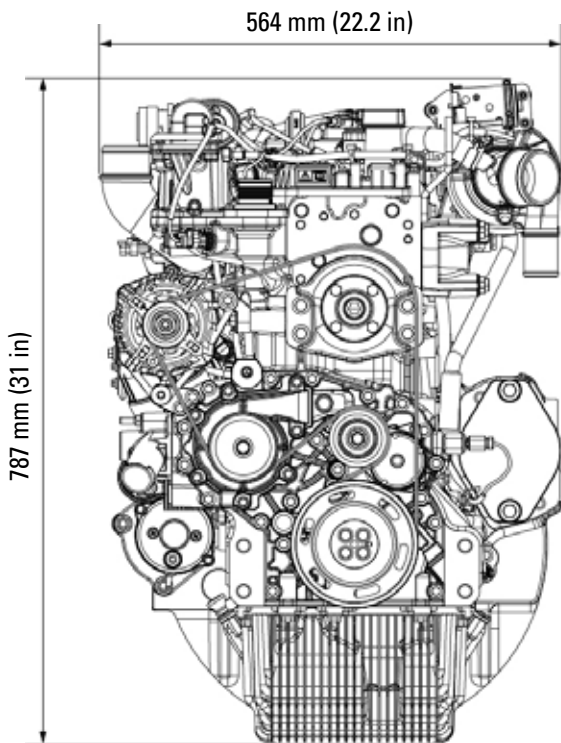
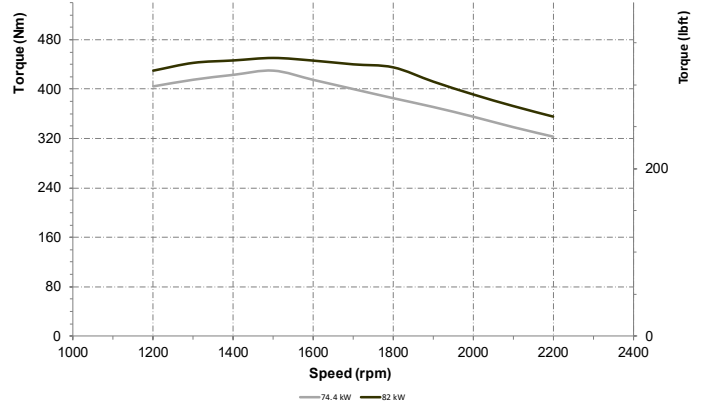
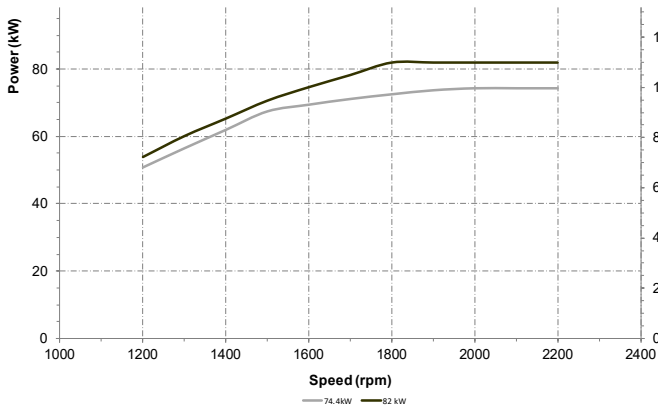

For additional information on all your power requirements, visit www.cat-industrial.com

All information in this document is substantially correct at time of printing and may be altered subsequently. Photographs are for illustrative purposes only and may not reflect final specification. Final weight and dimensions will depend on completed specification. Information subject to selected configuration, and subject to change without notice. Engine power measured per ISO 14396:2002

AEXJ0115-01 (01-22)

© 2022 Caterpillar. All Rights Reserved. CAT, CATERPILLAR, LET'S DO THE WORK, their respective logos, "Caterpillar Corporate Yellow", the "Power Edge" and Cat "Modern Hex" trade dress as well as corporate and product identity used herein, are trademarks of Caterpillar and may not be used without permission.