

904EA-E36TA

Industrial Engine

China Nonroad Stage IV
74.4-82 kW (100-110 hp)

The Perkins® 904 Series offers a compact power solution for off-highway applications in construction and industrial. These compact, 4 cylinder engines provide excellent performance in power, peak and low speed torque, fuel consumption and transient response.

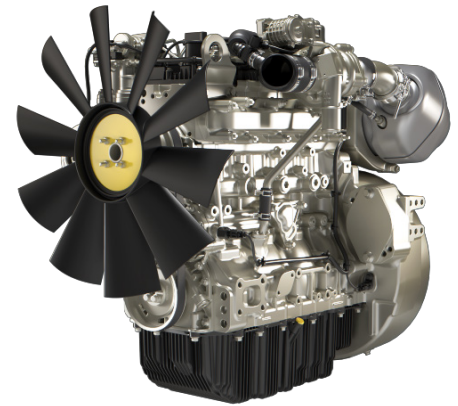

Features and benefits

Dependable power

The engine has been designed using the latest predictive engineering methods, combined with an extensive field validation program to provide reliable power in the toughest off-highway conditions. Quality, reliability and consistency are assured. Our facilities worldwide employ the same efficient processes, the same tested and validated components, and the same stringent quality controls wherever your engines are manufactured.

Lifetime of low cost

Fuel consumption is optimised to match the operating cycles of a wide range of off-highway applications. Hydraulic tappets, multi-vee belts and 500 hour service intervals enable low cost maintenance.

Industry leading flexibility

A modular engine concept allows OEMs to design one engine installation for different regions. This reduces cost and development time for cooling pack, mounting, hydraulic and control interfaces.

Local support, global coverage

Perkins recognise that the customer relationship is important to machine manufacturers and we can offer a range of flexible solutions to help provide appropriate support, either to the OEMs network or directly to the machine customer.

| Specification | |
|---|--------------------------|
| Cylinders | 4 |
| Displacement, litres (in ³) | 3.6 |
| Aspiration | Turbocharged aftercooled |
| Bore and stroke, mm (in) | 98 x 120 (3.9 x 4.7) |
| Maximum power, kW (hp) | 82 (110) |
| Rated speed, rpm | 2200 |
| Maximum torque, Nm (lb ft) @ rpm | 450 (331.7) @ 1500 |
| Combustion system | Direct injection |
| Weight, kg (lb) | 380 (839) |
| Rotation (viewed from flywheel) | Counterclockwise |

For more information please contact a Perkins distributor: <http://distributorlocator.perkins.com>

All information in this document is substantially correct at time of printing and may be altered subsequently.
Photographs are for illustrative purposes only and may not reflect final specification.
Final weight and dimensions will depend on completed specification.
Information subject to selected configuration, and subject to change without notice
Engine power measured per ISO 14396:2002
PN3262EN-02 (01-22) Produced in England ©2022 Perkins Engines Company Limited

 **Perkins**®

THE HEART OF EVERY GREAT MACHINE

904EA-E36TA

Industrial Engine

China Nonroad Stage IV
74.4-82 kW (100-110 hp)

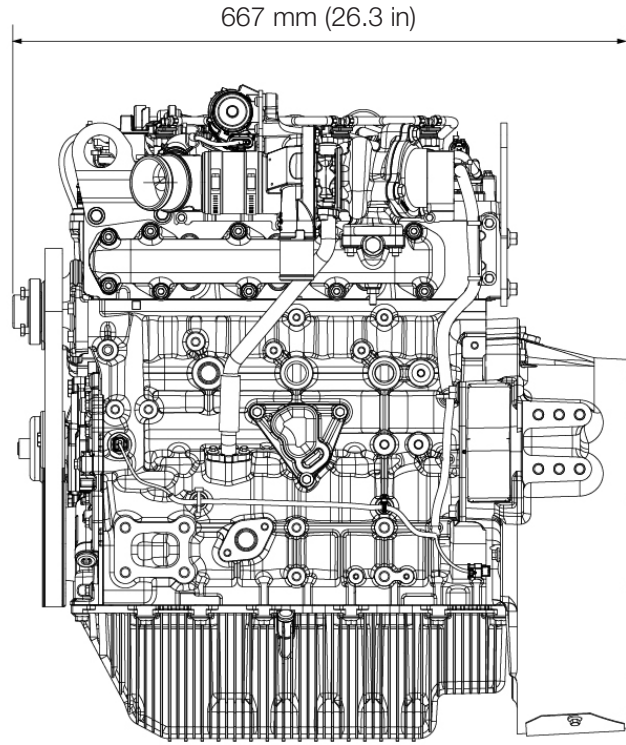
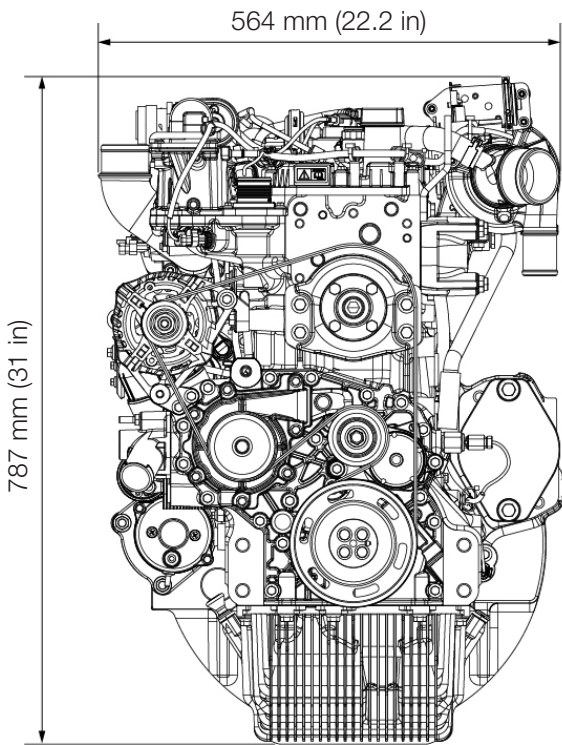
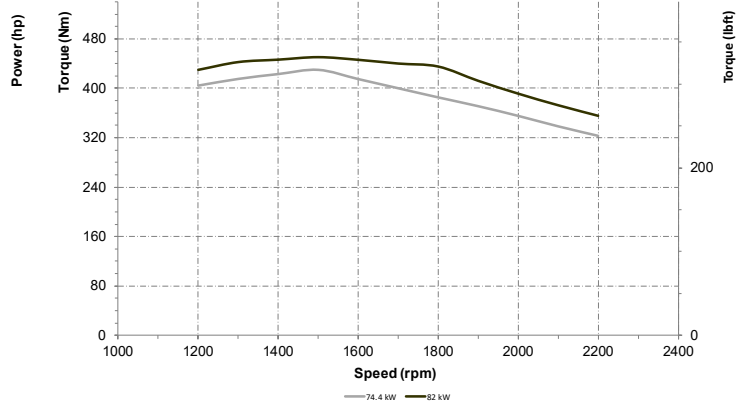
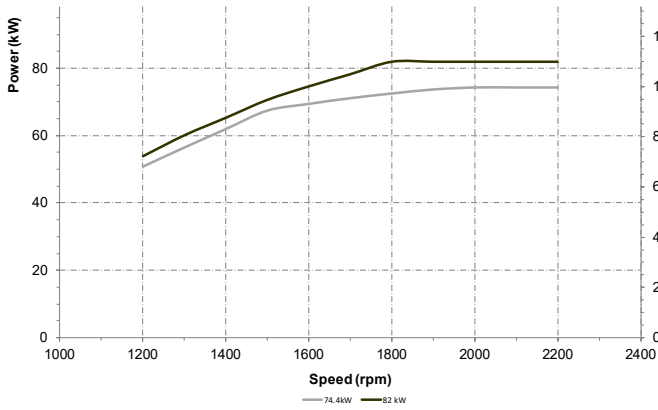

For more information please contact a Perkins distributor: <http://distributorlocator.perkins.com>

All information in this document is substantially correct at time of printing and may be altered subsequently.
Photographs are for illustrative purposes only and may not reflect final specification.
Final weight and dimensions will depend on completed specification.
Information subject to selected configuration, and subject to change without notice.
Engine power measured per ISO 14396:2002
PN3262EN-02 (01-22) Produced in England ©2022 Perkins Engines Company Limited



THE HEART OF EVERY GREAT MACHINE