

403EA-17

Industrial Engine

China Nonroad Stage IV
18.9 kW (25.3 hp)

The 403EA-17 is an indirect injection industrial diesel engine meeting China Nonroad Stage IV emission standards without the need for electronic control, aftertreatment or exhaust gas recirculation. It is available with many factory configurable options to minimise the costs of machine development and of manufacturing.



Features and benefits

Reliable power

The Perkins® 400 Series has been proven to deliver durable power. Manufactured in highly automated, state-of-the-art production facilities, the 400 Series is available in a wide range of factory configurable options.

Tailored for your machines

The 403EA-17 is one of four engine options from Perkins at 18.9 kW (25.3 hp) allowing OEMs to balance different installation, operating and commercial requirements. This model is particularly adapted to machines which need high torque, low speed operation or good cold start capability.

Quiet

The stiff block and indirect injection system make this a quiet engine, minimising operator fatigue and saving money for OEMs in sound attenuation measures.

| Specification | |
|---|----------------------|
| Cylinders | 3 |
| Displacement, litres (in ³) | 1.7 |
| Aspiration | Naturally aspirated |
| Bore and stroke, mm (in) | 84 x 100 (3.3 x 3.9) |
| Maximum power, kW (hp) | 18.9 (25.3) |
| Rated speed, rpm | 2200 |
| Maximum torque, Nm (lb ft) @ rpm | 97.9 (72.2) @ 1400 |
| Combustion system | Indirect injection |
| Weight, kg (lb) | 158 (348) |
| Rotation (viewed from flywheel) | Counterclockwise |

For more information please contact a Perkins distributor: <http://distributorlocator.perkins.com>

All information in this document is substantially correct at time of printing and may be altered subsequently.
Photographs are for illustrative purposes only and may not reflect final specification.
Final weight and dimensions will depend on completed specification.
Information subject to selected configuration, and subject to change without notice.
Engine power measured per ISO 14396:2002
PN3260/08/21 Produced in England ©2021 Perkins Engines Company Limited

 **Perkins**®

THE HEART OF EVERY GREAT MACHINE

403EA-17

Industrial Engine

China Nonroad Stage IV

18.9 kW (25.3 hp)

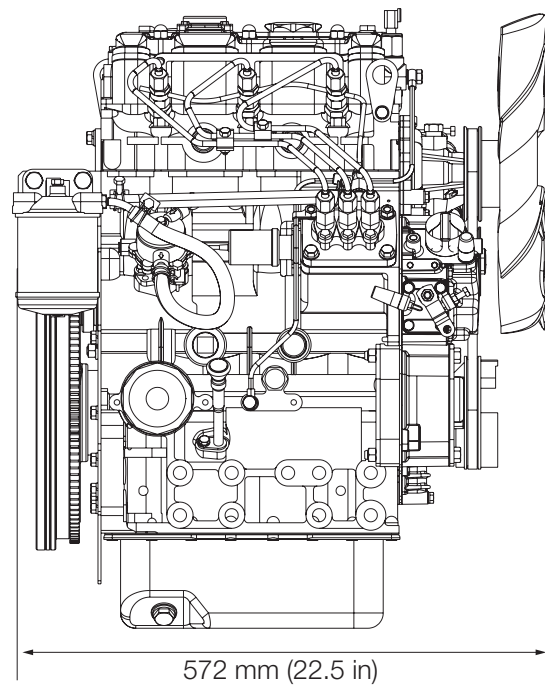
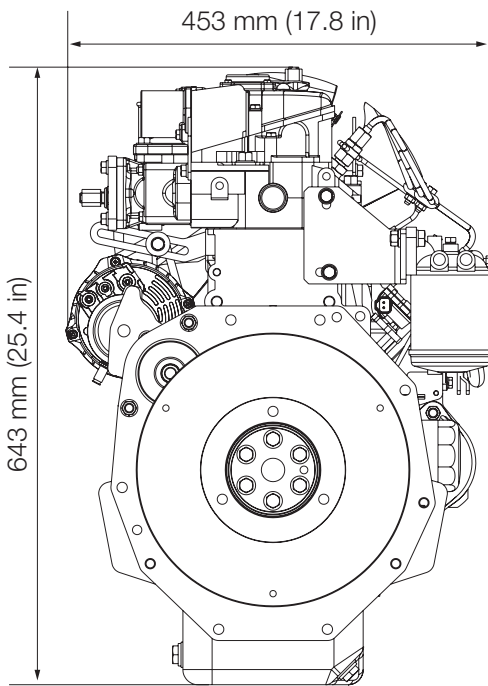
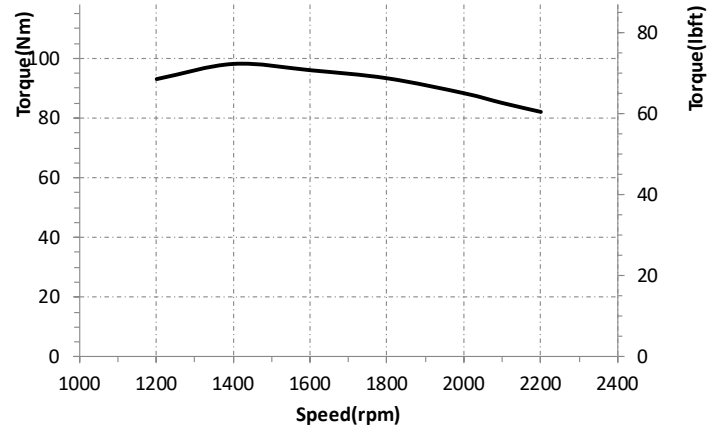
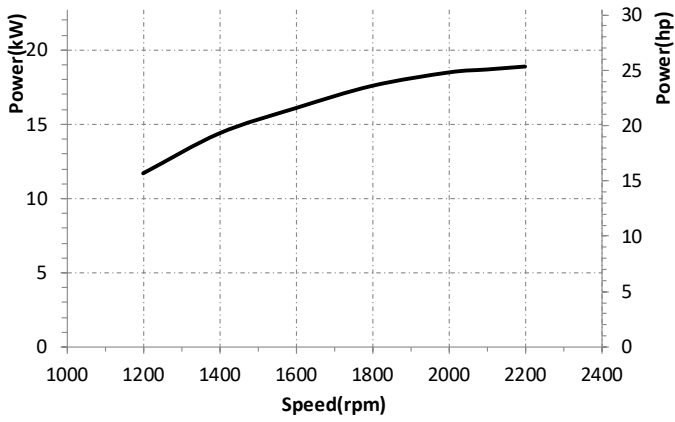

For more information please contact a Perkins distributor: <http://distributorlocator.perkins.com>

All information in this document is substantially correct at time of printing and may be altered subsequently.
Photographs are for illustrative purposes only and may not reflect final specification.
Final weight and dimensions will depend on completed specification.
Information subject to selected configuration, and subject to change without notice.
Engine power measured per ISO 14396:2002
PN3260/08/21 Produced in England ©2021 Perkins Engines Company Limited

 **Perkins**[®]

THE HEART OF EVERY GREAT MACHINE