



Cat[®] 304

MINI EXCAVATOR

FEATURES:

The Cat[®] 304 Mini Excavator delivers power and performance in a compact size to help you work in a wide range of applications.

ALL DAY COMFORT

- Choose either a canopy (not available in some regions) or a sealed and pressurized cab which can be equipped with air conditioning, adjustable wrist rests, and a suspension seat to help keep you working comfortably all day long.

EASY TO OPERATE

- Controls are easy to use and the intuitive Next Generation LCD monitor provides easy to read machine information. An advanced touchscreen monitor can also be equipped as an upgrade option.

STICK STEER TRAVEL MODE

- Moving around the job site is even easier with the Cat Stick Steer option. Easily switch from traditional travel controls with levers and pedals to joystick controls to move the machine and to operate the blade. The benefit of less effort and improved control is in your hands!

BIG PERFORMANCE IN A SMALL MACHINE

- Strong lift and dig performance helps you get the job done faster. The reduced radius tail swing design provides exceptional stability and performance. With a maximum width of 1700 mm (67 in), the 304 can access those hard to get into areas. Dig-to-blade and dozer blade float features allow for easy cleanup. An angle blade is also an option for finished grading and easier backfilling applications.

SAFETY ON THE JOB SITE

- Your safety is our top priority. The Cat mini excavator is designed to help keep you safe on the job. Courtesy work lights and a fluorescent retractable seat belt with optional seat belt reminder system are just a couple of the safety features we've built into the machine.

SIMPLE SERVICE FOR LESS DOWNTIME

- Maintenance is quick and easy on the Cat mini excavator. Routine check points are easy to access at ground level through the side doors.

LOWER OPERATING COSTS

- Equipped with features such as auto idle, auto engine shutdown, and efficient hydraulics with a variable displacement pump, the Cat mini excavator was designed with reducing your operating costs in mind.

UNMATCHED DEALER SUPPORT

- Your Cat dealer is here to help you reach your business goals. From providing equipment solutions to operator training to service needs and beyond, your Cat dealer is ready to help.

Specifications

Engine

Engine Model	C1.7 Turbo	
Net Power		
ISO 9249, 80/1269/EEC	33.6 kW	45.0 hp
Engine Power		
ISO 14396	36.1 kW	48.4 hp
Bore	84.0 mm	3.3 in
Stroke	100.0 mm	3.9 in
Displacement	1.662 L	101 in ³

- Meets U.S. EPA Tier 4 Final and EU Stage V emissions standards.
- Advertised power is tested per the specified standard in effect at the time of manufacture.
- Net power advertised is the power available at the flywheel when the engine is at the rated speed of 2,400 rpm and the engine is installed with the factory configured fan, air intake system, exhaust system and alternator with a minimum alternator load.

Weights

Minimum Operating Weight with Canopy*	3925 kg	8,655 lb
Maximum Operating Weight with Canopy**	4375 kg	9,647 lb
Minimum Operating Weight with Cab*	4025 kg	8,875 lb
Maximum Operating Weight with Cab**	4475 kg	9,867 lb

*Minimum Weight is based on rubber tracks, operator, full fuel tank, standard stick, straight blade, no bucket and no extra counterweight.

**Maximum Weight is based on steel tracks, operator, full fuel tank, long stick, straight blade, extra counterweight and no bucket.

Weight Increase from Minimum Configuration

Counterweight	225 kg	496 lb
Long Stick	30 kg	66 lb
Steel Tracks	195 kg	430 lb
Angle Blade	110 kg	243 lb

Travel System

Travel Speed – High	5.2 km/h	3.2 mph
Travel Speed – Low	3.5 km/h	2.2 mph
Maximum Traction Force – High Speed	19 kN	4,271 lbf
Maximum Traction Force – Low Speed	32.6 kN	7,329 lbf
Ground Pressure – Minimum Weight	28.7 kPa	4.2 psi
Ground Pressure – Maximum Weight	33.8 kPa	4.9 psi
Gradeability (maximum)	30 degrees	

Service Refill Capacities

Cooling System	11.0 L	2.9 gal
Engine Oil	6.0 L	1.6 gal
Fuel Tank	64.0 L	17.0 gal
Hydraulic Tank	52.0 L	14.0 gal
Hydraulic System	65.0 L	17.0 gal

Hydraulic System

Load Sensing Hydraulics with Variable Displacement Piston Pump		
Pump Flow @ 2,400 rpm	96 L/min	25 gal/min
Operating Pressure – Equipment	245 bar	3,553 psi
Operating Pressure – Travel	245 bar	3,553 psi
Operating Pressure – Swing	180 bar	2,611 psi
Auxiliary Circuit – Primary		
Flow*	65 L/min	21 gal/min
Pressure*	245 bar	3,553 psi
Auxiliary Circuit – Secondary		
Flow*	28 L/min	7.0 gal/min
Pressure*	245 bar	3,553 psi
Digging Force – Stick (standard)	21.0 kN	4,721 lbf
Digging Force – Stick (long)	19.2 kN	4,316 lbf
Digging Force – Bucket	38.2 kN	8,588 lbf

*Flow and pressure are not combinable. Under load, as flow rises pressure goes down.

Swing System

Machine Swing Speed	9.0 rpm
Boom Swing – Left	78 Degrees
Boom Swing – Right	50 Degrees

Blade

Width (Straight)	1700 mm	66.9 in
Height (Straight)	360 mm	14.2 in
Width (Angle)	1700 mm	66.9 in
Height (Angle)	360 mm	14.2 in
Angle Blade – Left	25 Degrees	
Angle Blade – Right	25 Degrees	

Certification – Cab and Canopy

Roll Over Protective Structure (ROPS)	ISO 12117-2:2008
Top Guard	ISO 10262:1998 Level I

Specifications (continued)

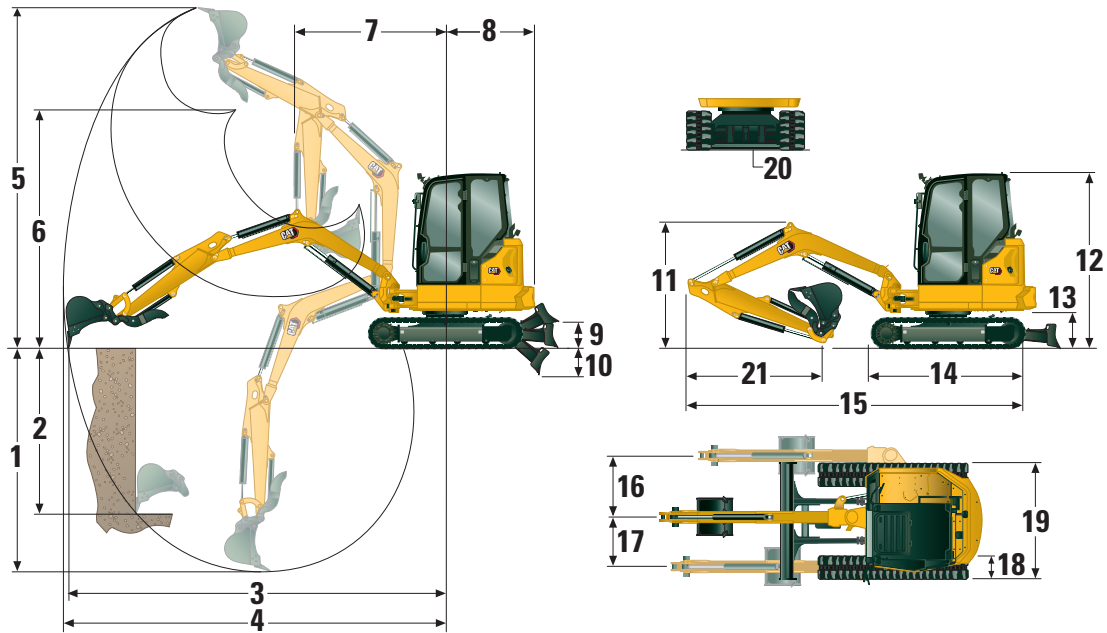

Dimensions

	Standard Stick	Long Stick
1 Dig Depth	3210 mm (126.4 in)	3510 mm (138.2 in)
2 Vertical Wall	2395 mm (94.3 in)	2535 mm (99.8 in)
3 Maximum Reach at Ground Level	5200 mm (204.7 in)	5445 mm (214.4 in)
4 Maximum Reach	5330 mm (209.8 in)	5570 mm (219.3 in)
5 Maximum Dig Height	5040 mm (198.4 in)	5125 mm (201.8 in)
6 Maximum Dump Clearance	3645 mm (143.5 in)	3740 mm (147.2 in)
7 Boom in Reach	2255 mm (88.8 in)	2340 mm (92.1 in)
8 Tail Swing		
without Counterweight	1205 mm (47.4 in)	1205 mm (47.4 in)
with Counterweight	1300 mm (51.2 in)	1300 mm (51.2 in)
9 Maximum Blade Height	420 mm (16.5 in)	420 mm (16.5 in)
10 Maximum Blade Depth	475 mm (18.7 in)	475 mm (18.7 in)
11 Boom Height in Shipping Position	1620 mm (63.8 in)	1910 mm (75.2 in)
12 Overall Shipping Height	2540 mm (100.0 in)	2540 mm (100.0 in)
13 Swing Bearing Height	557 mm (21.9 in)	557 mm (21.9 in)
14 Overall Undercarriage Length	2210 mm (87.0 in)	2210 mm (87.0 in)
15 Overall Shipping Length†	4950 mm (194.9 in)	4950 mm (194.9 in)
16 Boom Swing Right	730 mm (28.7 in)	730 mm (28.7 in)
17 Boom Swing Left	530 mm (20.9 in)	530 mm (20.9 in)
18 Track Belt/Shoe Width	350 mm (13.8 in)	350 mm (13.8 in)
19 Track Width	1700 mm (66.9 in)	1700 mm (66.9 in)
20 Ground Clearance	305 mm (12.0 in)	305 mm (12.0 in)
21 Stick Length	1395 mm (54.9 in)	1695 mm (66.7 in)

†Overall Shipping Length depends on blade position during shipment.

304 Mini Excavator

Cab

Lift Capacities – Minimum Configuration			Lift Point Radius – 3 m (9.8 ft)			Lift Point Radius – 4.5 m (14.8 ft)			Lift Point Radius (Maximum)			m (ft)
			Over Front		Over Side	Over Front		Over Side	Over Front		Over Side	
Lift Point Height			Blade Down	Blade Up		Blade Down	Blade Up		Blade Down	Blade Up		Over Side
3 m (9.8 ft)	Standard Stick	kg (lb)	*941 (*2,075)	*941 (*2,075)	*941 (*2,075)			*698 (*1,539)	*698 (*1,539)	*698 (*1,539)	4.09 (13.4)	
	Long Stick	kg (lb)						*699 (*1,541)	*699 (*1,541)	*699 (*1,541)	4.37 (14.3)	
1.5 m (4.9 ft)	Standard Stick	kg (lb)	*1522 (*3,356)	1213 (2,675)	1031 (2,273)	*1040 (*2,293)	662 (1,460)	573 (1,263)	*698 (*1,539)	*698 (*1,539)	555 (1,224)	4.59 (15.1)
	Long Stick	kg (lb)	*1333 (*2,939)	*1333 (*2,939)	1029 (2,269)	*1008 (*2,223)	652 (1,438)	562 (1,239)	*711 (*1,568)	582 (1,283)	502 (1,107)	4.84 (15.9)
0 m (0 ft)	Standard Stick	kg (lb)	*2006 (*4,423)	1148 (2,531)	969 (2,137)				*846 (*1,865)	656 (1,446)	566 (1,248)	4.46 (14.6)
	Long Stick	kg (lb)	*1933 (*4,262)	1128 (2,487)	950 (2,095)	*1142 (*2,518)	630 (1,389)	541 (1,193)	*861 (*1,899)	591 (1,303)	508 (1,120)	4.71 (15.5)

Minimum Weight includes cab, rubber tracks, no counterweight, operator, full fuel tank and straight blade.

Lift Capacities – Maximum Configuration			Lift Point Radius – 3 m (9.8 ft)			Lift Point Radius – 4.5 m (14.8 ft)			Lift Point Radius (Maximum)			m (ft)
			Over Front		Over Side	Over Front		Over Side	Over Front		Over Side	
Lift Point Height			Blade Down	Blade Up		Blade Down	Blade Up		Blade Down	Blade Up		Over Side
3 m (9.8 ft)	Standard Stick	kg (lb)	*941 (*2,075)	*941 (*2,075)	*941 (*2,075)				*698 (*1,539)	*698 (*1,539)	*698 (*1,539)	4.09 (13.4)
	Long Stick	kg (lb)							*699 (*1,541)	*699 (*1,541)	*699 (*1,541)	4.37 (14.3)
1.5 m (4.9 ft)	Standard Stick	kg (lb)	*1522 (*3,356)	*1522 (*3,356)	1266 (2,792)	*1040 (*2,293)	780 (1,720)	714 (1,574)	*698 (*1,539)	*698 (*1,539)	*698 (*1,539)	4.59 (15.1)
	Long Stick	kg (lb)	*1333 (*2,939)	*1333 (*2,939)	*1333 (*2,939)	*1008 (*2,223)	769 (1,696)	703 (1,550)	*711 (*1,568)	*711 (*1,568)	*711 (*1,568)	4.84 (15.9)
0 m (0 ft)	Standard Stick	kg (lb)	*2006 (*4,423)	1349 (2,975)	1204 (2,655)				*846 (*1,865)	*846 (*1,865)	709 (1,563)	4.46 (14.6)
	Long Stick	kg (lb)	*1933 (*4,262)	1329 (2,930)	1185 (2,613)	*1142 (*2,518)	748 (1,649)	682 (1,504)	*861 (*1,899)	702 (1,548)	641 (1,413)	4.71 (15.5)

Maximum Weight includes cab, steel tracks, counterweight, operator, full fuel tank and angle blade.

Canopy

Lift Capacities – Minimum Configuration			Lift Point Radius – 3 m (9.8 ft)			Lift Point Radius – 4.5 m (14.8 ft)			Lift Point Radius (Maximum)			m (ft)
			Over Front		Over Side	Over Front		Over Side	Over Front		Over Side	
Lift Point Height			Blade Down	Blade Up		Blade Down	Blade Up		Blade Down	Blade Up		Over Side
3 m (9.8 ft)	Standard Stick	kg (lb)	*941 (*2,075)	*941 (*2,075)	*941 (*2,075)				*698 (*1,539)	*698 (*1,539)	*698 (*1,539)	4.09 (13.4)
	Long Stick	kg (lb)							*699 (*1,541)	*699 (*1,541)	585 (1,290)	4.37 (14.3)
1.5 m (4.9 ft)	Standard Stick	kg (lb)	*1522 (*3,356)	1176 (2,593)	1000 (2,205)	*1040 (*2,293)	640 (1,411)	555 (1,224)	*698 (*1,539)	*698 (*1,539)	537 (1,184)	4.59 (15.1)
	Long Stick	kg (lb)	*1333 (*2,939)	*1333 (*2,939)	999 (2,203)	*1008 (*2,223)	630 (1,389)	544 (1,200)	*711 (*1,568)	562 (1,239)	485 (1,069)	4.84 (15.9)
0 m (0 ft)	Standard Stick	kg (lb)	*2006 (*4,423)	1111 (2,450)	939 (2,070)				*846 (*1,865)	634 (1,398)	548 (1,208)	4.46 (14.6)
	Long Stick	kg (lb)	*1933 (*4,262)	1091 (2,406)	919 (2,026)	*1142 (*2,518)	608 (1,341)	523 (1,153)	*861 (*1,899)	570 (1,257)	490 (1,080)	4.71 (15.5)

Minimum Weight includes canopy, rubber tracks, no counterweight, operator, full fuel tank and straight blade.

Lift Capacities – Maximum Configuration			Lift Point Radius – 3 m (9.8 ft)			Lift Point Radius – 4.5 m (14.8 ft)			Lift Point Radius (Maximum)			m (ft)
			Over Front		Over Side	Over Front		Over Side	Over Front		Over Side	
Lift Point Height			Blade Down	Blade Up		Blade Down	Blade Up		Blade Down	Blade Up		Over Side
3 m (9.8 ft)	Standard Stick	kg (lb)	*941 (*2,075)	*941 (*2,075)	*941 (*2,075)				*698 (*1,539)	*698 (*1,539)	*698 (*1,539)	4.09 (13.4)
	Long Stick	kg (lb)							*699 (*1,541)	*699 (*1,541)	*699 (*1,541)	4.37 (14.3)
1.5 m (4.9 ft)	Standard Stick	kg (lb)	*1522 (*3,356)	*1522 (*3,356)	1235 (2,723)	*1040 (*2,293)	758 (1,671)	696 (1,535)	*698 (*1,539)	*698 (*1,539)	*698 (*1,539)	4.59 (15.1)
	Long Stick	kg (lb)	*1333 (*2,939)	*1333 (*2,939)	*1333 (*2,939)	*1008 (*2,223)	748 (1,649)	685 (1,510)	*711 (*1,568)	*711 (*1,568)	*711 (*1,568)	4.84 (15.9)
0 m (0 ft)	Standard Stick	kg (lb)	*2006 (*4,423)	1312 (2,893)	1174 (2,589)				*846 (*1,865)	*846 (*1,865)	691 (1,524)	4.46 (14.6)
	Long Stick	kg (lb)	*1933 (*4,262)	1292 (2,849)	1154 (2,545)	*1142 (*2,518)	726 (1,601)	664 (1,464)	*861 (*1,899)	681 (1,502)	624 (1,376)	4.71 (15.5)

Maximum Weight includes canopy, steel tracks, counterweight, operator, full fuel tank and angle blade.

*The above loads are in compliance with hydraulic excavator lift capacity rating standard ISO 10567:2007 and they do not exceed 87% of hydraulic lifting capacity or 75% of tipping capacity. The excavator bucket weight is not included on this chart.

Standard and Optional Equipment

Standard and optional equipment may vary. Consult your Cat dealer for details.

	Standard	Optional		Standard	Optional
ENGINE			OPERATOR ENVIRONMENT (continued)		
Cat® C1.7 Turbo Engine (U.S. EPA Tier 4 Final/ EU Stage V)	✓		Hydraulic Lockout – All Controls	✓	
Automatic Engine Idle	✓		Retractable High Visibility Seat Belt (75 mm/3 in)	✓	
Automatic Engine Shutdown	✓		Seat Belt Reminder System		✓
Automatic Two Speed Travel	✓		Coat Hook	✓	
Fuel Water Separator	✓		Cup Holder	✓	
Power on Demand (not available in all regions)	✓		Storage Pocket	✓	
Variable Displacement Piston Pump	✓		Skylight	✓	
Load Sensing/Flow Sharing Hydraulics	✓		Mounting Bosses for Front	✓	
HYDRAULICS			Signaling/Warning Horn	✓	
Smart Tech Electronic Pump	✓		Interior Light (Cab only)	✓	
Accumulator	✓		Boom Light, Halogen (not available in all regions)	✓	
Automatic Swing Brake	✓		LED Front Lights	✓	
Auxiliary Hydraulic Lines	✓		LED Front and Rear Lights		✓
One and Two Way Auxiliary Flow	✓		LED Boom Light	✓	
Continuous Auxiliary Flow	✓		Utility Space for Mobile Phone	✓	
Auxiliary Line Quick Disconnects	✓		Mirrors, Left, Right and Rear		✓
OPERATOR ENVIRONMENT			Camera		✓
Canopy or Cab (Canopy not available in some regions)	✓		Radio – Bluetooth®, Auxiliary, Microphone, USB (charging only) (Cab only)		✓
Cab with Air Conditioning		✓	Next Generation Color LCD Monitor (IP66)	✓	
Cab with Heater		✓	– Fuel Level and Coolant Temperature Gauges	✓	
Stick Steer Mode	✓		– Maintenance and Machine Monitoring	✓	
Travel Cruise Control	✓		– Performance and Machine Adjustments	✓	
Control Pattern Changer (optional in some regions)	✓		– Numeric Security Code	✓	
Adjustable Wrist Rests	✓		– Multiple Languages	✓	
Washable Floor Mat	✓		– Hour Meter with Wake Up Switch	✓	
Travel Pedals and Hand Levers	✓		– Jog Dial (cab only)	✓	
No Travel Pedals and Hand Levers (optional in some regions)		✓	Next Generation Advanced Monitor		✓
Machine Security	✓		– Touch Screen		✓
Standard Key with Pass Code	✓		– Site Reference System		✓
Push to Start with Key Fob/Pass Code		✓	– High Definition Camera Capable (IP68 and IP69K)		✓
Fabric Suspension Seat (Cab only)	✓		– Numeric Security Code		✓
Vinyl Suspension Seat (Canopy only)	✓		UNDERCARRIAGE		
			Rubber Belt (350 mm/13.8 in)	✓	
			Steel Track (350 mm/13.8 in)		✓
			Steel Track with Rubber Pads		✓
			Dozer Straight Blade	✓	
			Dozer Blade Float	✓	
			Angle Blade		✓
			Tie Downs on Track Frame	✓	

(continued on next page)

304 Mini Excavator

Standard and Optional Equipment *(continued)*

Standard and optional equipment may vary. Consult your Cat dealer for details.

	Standard	Optional		Standard	Optional
BOOM, STICK AND LINKAGES			GUARDING		
One Piece Boom (2500 mm/98.4 in)	✓		Roll Over Protective Structure (ROPS) ISO 12117-2:2008	✓	
Standard Stick (1395 mm/54.9 in)	✓		Top Guard ISO 10262:1998 (Level I)	✓	
Long Stick (1695 mm/66.7 in)		✓	Top Guard ISO 10262:1998 (Level II)		✓
Front Shovel Capable	✓		Front Guard (Mesh) ISO 10262:1998 (Level I)		✓
Pin-On	✓		Front Guard (Heavy Duty) ISO 10262:1998 (Level II)		✓
Dual Lock Manual Coupler		✓	OTHER		
Hydraulic Coupler		✓	Eco Drain	✓	
Thumb Ready	✓		Bio Oil Capable		✓
Certified Lifting Eye	✓		Water Jacket Heater		✓
Attachments including Couplers, Thumbs, Buckets, Augers and Hammers		✓	Counterweight (225 kg/496 lb)		✓
2nd Auxiliary Hydraulic Lines		✓			
Bucket Divert Lines		✓			
Boom Lowering Check Valve		✓			
Stick Lowering Check Valve		✓			
Hydraulic Quick Coupler Lines		✓			
ELECTRICAL					
12 Volt Battery	✓				
Software (machine and monitor)	✓				
Maintenance Free Battery	✓				
Battery Disconnect	✓				
12 Volt Power Socket	✓				
Product Link™ PL243 (regulations apply)		✓			
Product Link PLE643 (regulations apply)		✓			
Cat Grade Advanced 2D		✓			
Cat Grade 3D		✓			
Travel Alarm (optional in some regions)	✓				

The following information applies to the machine at the time of final manufacture as configured for sale in the regions covered in this document. The content of this declaration is valid as of the date issued; however, content related to machine features and specifications are subject to change without notice. For additional information, please see the machine's Operation and Maintenance Manual.

For more information on sustainability in action and our progress, please visit <https://www.caterpillar.com/en/company/sustainability>.

Engine

- The Cat® C1.7 Turbo engine meets U.S. EPA Tier 4 Final and EU Stage V emission standards.
- Cat diesel engines are required to use ULSD (ultra-low sulfur diesel fuel with 15 ppm of sulfur or less) or ULSD blended with the following lower-carbon intensity fuels** up to:
 - ✓ 20% biodiesel FAME (fatty acid methyl ester)*
 - ✓ 100% renewable diesel, HVO (hydrotreated vegetable oil) and GTL (gas-to-liquid) fuels
 Refer to guidelines for successful application. Please consult your Cat dealer or “Caterpillar Machine Fluids Recommendations” (SEBU6250) for details.

**Engines with no aftertreatment devices can use higher blends, up to 100% biodiesel (for use of blends higher than 20% biodiesel, consult your Cat dealer).*

***Tailpipe greenhouse gas emissions from lower-carbon intensity fuels are essentially the same as traditional fuels.*

Air Conditioning System

- The air conditioning system on this machine contains the fluorinated greenhouse gas refrigerant R134a (Global Warming Potential = 1430). The system contains 1.0 kg (2.2 lb) of refrigerant which has a CO₂ equivalent of 1.430 metric tonnes (1.576 tons).

Paint

- Based on best available knowledge, the maximum allowable concentration, measured in parts per million (PPM), of the following heavy metals in paint are:
 - Barium < 0.01%
 - Cadmium < 0.01%
 - Chromium < 0.01%
 - Lead < 0.01%

Sound Performance

Operator Sound Pressure 76 dB(A) (ISO 6396:2008)*

Exterior Sound Power Level 97 dB(A) (ISO 6395:2008)**

*The declared dynamic operator sound pressure levels per ISO 6396:2008. The measurements were conducted with the cab doors and windows closed.

- **The labeled sound power level for the CE marked configurations when measured according to the test procedure and conditions specified in 2000/14/EC.

Oils and Fluids

- Caterpillar factory fills with ethylene glycol coolants. Cat Diesel Engine Antifreeze/Coolant (DEAC) and Cat Extended Life Coolant (ELC) can be recycled. Consult your Cat dealer for more information.
- Cat Bio HYDO™ Advanced is an EU Ecolabel approved biodegradable hydraulic oil.
- Additional fluids are likely to be present, please consult the Operations and Maintenance Manual or the Application and Installation guide for complete fluid recommendations and maintenance intervals.

Features and Technology

- The following features and technology may contribute to fuel savings and/or carbon reduction. Features may vary. Consult your Cat dealer for details.
 - Advanced hydraulic systems balance power and efficiency
 - Power On Demand provides full time efficiency and power when you need it, and is transparent to the operator
 - Auto idle and auto engine shutdown
 - Extended maintenance intervals reduce fluid and filter consumption
 - Remote Flash and Remote Troubleshoot (if equipped)
 - Mini Hydraulic Excavator Ease of Use features improve operator efficiency minimizing fuel consumption (if equipped)
 - Cat Grade with Advanced 2D and 3D improves operator efficiency minimizing fuel consumption (if equipped)

Recycling

- The materials included in machines are categorized as below with approximate weight percentage. Because of variations of product configurations, the following values in the table may vary.

Material Type	Weight Percentage
Steel	65.52%
Iron	21.19%
Rubber	3.50%
Mixed Metal	2.20%
Other	1.89%
Nonferrous Metal	1.81%
Plastic	1.55%
Fluid	1.47%
Mixed-Metal and Nonmetal	0.85%
Mixed Nonmetallic	0.01%
Uncategorized	0.00%
Total	100.00%

- A machine with higher recyclability rate will ensure more efficient usage of valuable natural resources and enhance End-of-Life value of the product. According to ISO 16714 (Earth-moving machinery – Recyclability and recoverability – Terminology and calculation method), recyclability rate is defined as percentage by mass (mass fraction in percent) of the new machine potentially able to be recycled, reused or both.

All parts in the bill of material are first evaluated by component type based on a list of components defined by the ISO 16714 and Japan CEMA (Construction Equipment Manufacturers Association) standards. Remaining parts are further evaluated for recyclability based on material type.

Because of variations of product configurations, the following values in the table may vary.

Recyclability – 96%

304 Mini Excavator

For more complete information on Cat products, dealer services, and industry solutions, visit us on the web at www.cat.com

© 2024 Caterpillar
All rights reserved

Materials and specifications are subject to change without notice. Featured machines in photos may include additional equipment. See your Cat dealer for available options.

CAT, CATERPILLAR, LET'S DO THE WORK, their respective logos, "Caterpillar Corporate Yellow," the "Power Edge" and Cat "Modern Hex" trade dress as well as corporate and product identity used herein, are trademarks of Caterpillar and may not be used without permission.

AEHQ8377-02 (02-2024)
Replaces AEHQ8377-01
Build Number: 07A
(North America, Europe,
Australia/New Zealand)

