

404EA-22 and 404EA-22T

Industrial Engine

China Nonroad Stage IV

34.1-36.4 kW (45.7-48.8 hp)

The 404EA-22 and 404EA-22T are indirect injection industrial diesel engines meeting China Nonroad Stage IV emission standards without the need for electronic control, aftertreatment or exhaust gas recirculation. Available as naturally aspirated or turbocharged for improved low speed torque, we also offer a range of factory configurable options to minimise the cost of machine development and of manufacturing if equipped with e-controller.



Features and benefits

Dependable power

The Perkins® 400 Series has been proven to deliver durable power. Manufactured in highly automated, state-of-the-art production facilities, the 400 Series is available in a wide range of factory configurable options.

Tailored for your machines

The 404EA-22 and 404EA-22T are two of the four engine options available from Perkins at 34.1-36.4 kW (45.7-48.8 hp), enabling OEMs to balance different installation, operating and commercial requirements. These models are particularly suited to machines where power from a small package size is key, while the turbocharged variant also delivers improved altitude performance.

Quiet in service

The stiff block and indirect injection system make this a quiet engine, minimizing operator fatigue and saving money for OEMs in sound attenuation measures.

Specification	
Cylinders	4
Displacement, litres (in ³)	2.2
Aspiration	Naturally aspirated or turbocharged
Bore and stroke, mm (in)	84 x 100 (3.3 x 3.9)
Maximum power, kW (hp)	36.4 (48.8)
Rated speed, rpm	2500-2800
Maximum torque, Nm (lb ft) @ rpm	190 (140) @ 1700
Combustion system	Indirect injection
Weight, kg (lb)	194 (428)
Rotation (viewed from flywheel)	Counterclockwise

For more information please contact your local Perkins distributor: <http://distributorlocator.perkins.com>

All information in this document is substantially correct at time of printing and may be altered subsequently.
Photographs are for illustrative purposes only and may not reflect final specification.
Final weight and dimensions will depend on completed specification.
Information subject to selected configuration, and subject to change without notice.
Performance measured per ISO 14396:2002
PN3261/08/21 Produced in England ©2021 Perkins Engines Company Limited

 **Perkins**®

THE HEART OF EVERY GREAT MACHINE

404EA-22 and 404EA-22T

Industrial Engine

China Nonroad Stage IV

34.1-36.4 kW (45.7-48.8 hp)

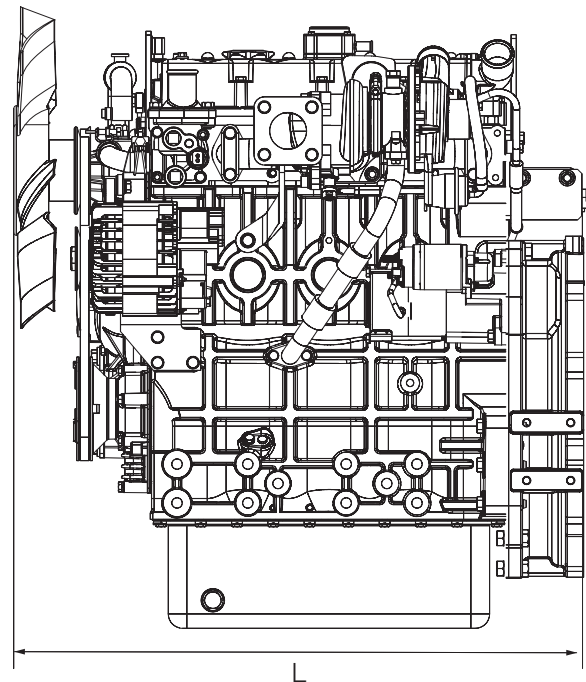
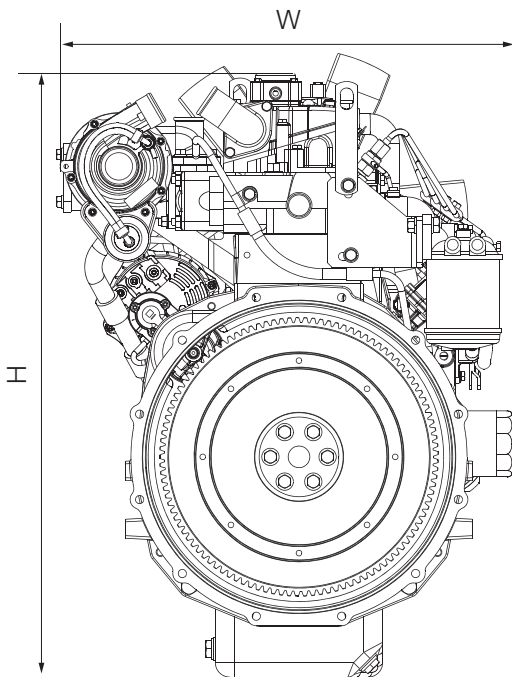
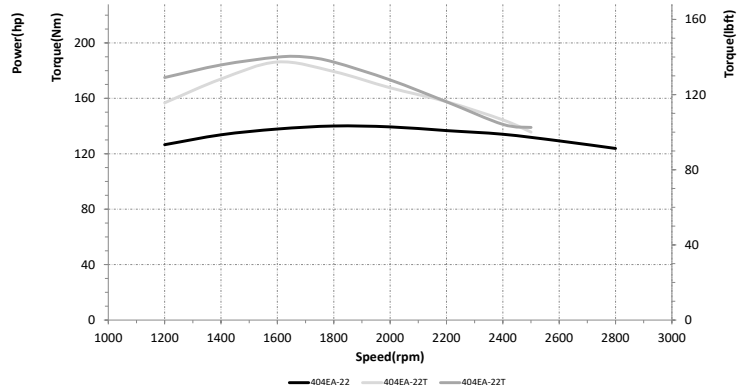
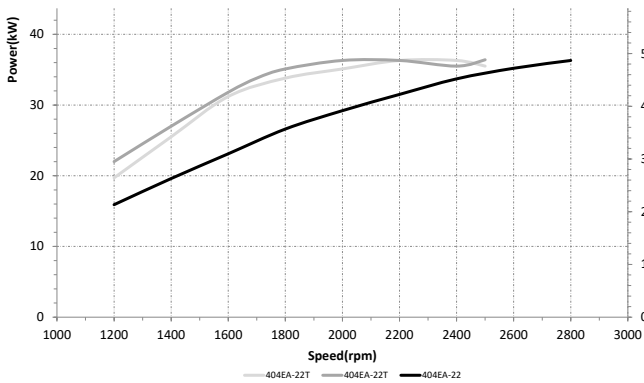

	Naturally aspirated	Turbocharged
Length (including fan), mm (in)	661 (26)	662 (26.1)
Width, mm (in)	464 (18.3)	489 (19.3)
Height, mm (in)	676 (26.6)	698 (27.5)
Weight, kg (lb)	184 (406)	194 (428)

For more information please contact your local Perkins distributor: <http://distributorlocator.perkins.com>

All information in this document is substantially correct at time of printing and may be altered subsequently. Photographs are for illustrative purposes only and may not reflect final specification. Final weight and dimensions will depend on completed specification. Information subject to selected configuration, and subject to change without notice. Performance measured per ISO 14396:2002. PN3261/08/21 Produced in England ©2021 Perkins Engines Company Limited



THE HEART OF EVERY GREAT MACHINE