

CAT[®] ATTACHMENTS

COMPACT WHEEL LOADERS





Get more out of your equipment with Cat® attachments.

Cat® attachments are designed and tested on each model to maximize machine performance.

This brochure consists of work tool offerings for compact wheel loader models:
 903D
 906, 907, 908
 910, 914, 920, 914K, 920K

ABBREVIATIONS

- CWL: Compact Wheel Loader
- BOCE: Bolt-on cutting edge
- WOT: Weld-on teeth
- BOT: Bolt-on teeth
- SSL: Skid Steer Loader
- STD: Standard
- HPL: Horizontal pin lock
- IT: Integrated tool carrier
- EU: Europe
- HF: High flow

INDEX

- COUPLER TYPES** 4
- CHOOSING THE RIGHT COUPLER** 6
- INTERFACE BRACKET SOLUTIONS** 7
- GROUND ENGAGING TOOLS** 8
- 903D ATTACHMENTS**
- BUCKETS**
 - GENERAL PURPOSE – SSL 13
 - LIGHT MATERIAL – SSL 13
 - MATERIAL HANDLING – SSL 14
 - PALLET FORK CARRIAGE AND FORKS – SSL 14
 - OTHER ATTACHMENTS – SSL 15
- 906, 907, 908 ATTACHMENTS**
- AUGERS**
 - DRIVE ASSEMBLIES (SSL) 18
 - ADAPTERS AND EXTENSTIONS 18
 - BITS 19
- BALE GRABS – SSL** 21
- BALE SPEARS – SSL** 21
- BLADES**
 - ANGLE – SSL 22
 - DOZER – SSL 22
- BROOMS**
 - ANGLE – SSL 23
 - PICKUP – SSL 24
 - UTILITY – SSL 25
 - ANGLE 26
 - PICKUP 26
 - BROOM KITS 27
- INDUSTRIAL BRUSHCUTTERS** 28
- BUCKETS**
 - GENERAL PURPOSE – SSL/HPL (L30)/HPL-A (ATLAS) 29
 - GENERAL PURPOSE – SSL/HPL-A (ATLAS) 30
 - INDUSTRIAL GRAPPLE – SSL 30
 - LIGHT MATERIAL – SSL/HPL (L30) 31
 - MULTI-PURPOSE – SSL/HPL (L30)/HPL-A (ATLAS) 32
 - MULTI-PURPOSE HEAVY DUTY – HPL (L30) 33
 - CONCRETE SLAB – SSL 33
 - STUMP – SSL 34
 - MIXING – SSL 34
 - SIDE DISCHARGE – SSL 35

COLD PLANERS

COLD PLANERS – SSL36
 KITS/DRUMS37

FORKS

PALLET FORK CARRIAGES – SSL/HPL/ATLAS38
 PALLET FORKS38
 HEAVY DUTY PALLET FORK CARRIAGE AND FORKS – SSL . 39

MATERIAL HANDLING ARM – SSL40

LANDSCAPE TILLERS – SSL40

LANDSCAPE RAKES – SSL41

POWER BOX RAKES – SSL42

NURSERY ATTACHMENTS

NURSERY FORKS43
 TREE SCOOP BUCKET45

SNOW ATTACHMENTS

SNOW BLOWERS – SSL46
 SNOW PERFORMANCE KIT – SSL46
 MULTI-V-PLOWS – SSL47
 SNOW WINGS – SSL47
 SNOW PLOWS – SSL48
 STRAIGHT SNOW PUSHES – SSL49
 BACK DRAG EDGES – SSL50

STUMP GRINDERS – SSL51

TRENCHERS

TRENCHERS – SSL52
 TRENCHER CHAINS – SSL53
 CRUMBER ARMS/SKID SHOES – SSL53

VIBRATORY DRUM COMPACTORS – SSL54

WHEEL SAW – SSL55

910, 914, 920, 914K, 920K ATTACHMENTS

ADAPTER HOOKS57

BROOMS

ANGLE59
 PICKUP60
 BROOM KITS61

BUCKETS

FLAT FLOOR – HPL – WIDE (L50)62
 GENERAL PURPOSE – IT/PIN ON/HPL (L50)/FUSION.63
 GENERAL PURPOSE – HPL (L50)/FUSION64
 HIGH DUMP – IT/HPL (L50)65
 LIGHT MATERIAL – IT/PIN ON66
 LIGHT MATERIAL – HPL (L50)/FUSION67
 MULTI-PURPOSE EXTREME DUTY – IT68
 MULTI-PURPOSE HEAVY DUTY – IT68

FORKS

PALLET FORK CARRIAGES – IT/HPL (L50)69
 PALLET CARRIAGES – FUSION70
 FORKS – PALLET71
 FORKS – OFFSET71

MATERIAL HANDLING ARM72

SNOW ATTACHMENTS

SNOW PLOWS73
 HEAVY DUTY SNOW PLOWS73
 STRAIGHT SNOW PUSHES74
 BUCKET RECEIVER SNOW PUSHES75

NOTE

Pages with **GRAY** bars at the bottom refer to Model 903D.

Pages with **ORANGE** bars at the bottom refer to Models 906, 907, 908.

Pages with **YELLOW** bars at the bottom refer to Models 910, 914, 920, 914K, 920K.



Indicates EU requires front-facing camera.

COMPACT WHEEL LOADERS ATTACHMENTS | 2021

General Purpose Performance Buckets have been designed to optimize performance of all 3rd Party Compact Wheel Loader applications, ensuring loading, grading and discharge in a wide range of applications and materials.



General Purpose Bucket

Part	Capacity	Weight	Length	Width	Height	Compatibility	Edge Type	Finish
903-001	1,000 (2,200)	1,000 (2,200)	36 (1,118)	36 (1,118)	27 (823)	903-001	903-001	903-001
903-002	1,500 (3,300)	1,500 (3,300)	42 (1,280)	42 (1,280)	33 (1,000)	903-002	903-002	903-002
903-003	2,000 (4,400)	2,000 (4,400)	48 (1,463)	48 (1,463)	39 (1,194)	903-003	903-003	903-003
903-004	2,500 (5,500)	2,500 (5,500)	54 (1,641)	54 (1,641)	45 (1,372)	903-004	903-004	903-004

Light Material Buckets have higher volume capacities. Buckets have been constructed with an ergonomic bucket, and a large end handle.



Light Material Bucket

Part	Capacity	Weight	Length	Width	Height	Compatibility	Edge Type	Finish
903-005	1,500 (3,300)	1,500 (3,300)	42 (1,280)	42 (1,280)	33 (1,000)	903-005	903-005	903-005
903-006	2,000 (4,400)	2,000 (4,400)	48 (1,463)	48 (1,463)	39 (1,194)	903-006	903-006	903-006
903-007	2,500 (5,500)	2,500 (5,500)	54 (1,641)	54 (1,641)	45 (1,372)	903-007	903-007	903-007

COMPACT WHEEL LOADERS ATTACHMENTS | 2021



Multi Purpose Buckets have the same loading capacity as existing buckets, with the added flexibility for digging, grading, dumping, pushing and handling a broad range of applications.



Multi Purpose Bucket

Part	Capacity	Weight	Length	Width	Height	Compatibility	Edge Type	Finish
903-008	1,000 (2,200)	1,000 (2,200)	36 (1,118)	36 (1,118)	27 (823)	903-008	903-008	903-008
903-009	1,500 (3,300)	1,500 (3,300)	42 (1,280)	42 (1,280)	33 (1,000)	903-009	903-009	903-009
903-010	2,000 (4,400)	2,000 (4,400)	48 (1,463)	48 (1,463)	39 (1,194)	903-010	903-010	903-010
903-011	2,500 (5,500)	2,500 (5,500)	54 (1,641)	54 (1,641)	45 (1,372)	903-011	903-011	903-011

COMPACT WHEEL LOADERS ATTACHMENTS | 2021

General Purpose Bucket

Light Material Bucket

Part	Capacity	Weight	Length	Width	Height	Compatibility	Edge Type	Finish
903-012	1,500 (3,300)	1,500 (3,300)	42 (1,280)	42 (1,280)	33 (1,000)	903-012	903-012	903-012
903-013	2,000 (4,400)	2,000 (4,400)	48 (1,463)	48 (1,463)	39 (1,194)	903-013	903-013	903-013
903-014	2,500 (5,500)	2,500 (5,500)	54 (1,641)	54 (1,641)	45 (1,372)	903-014	903-014	903-014

Types of Couplers

Cat Coupler Solutions

SSL

The universal skid steer loader (SSL) coupler allows the use of many Cat skid steer loader work tools. Using either the standard or high flow auxiliary line hydraulic option, this coupler allows compact wheel loaders to work with skid steer loader attachments.

– Also known as Vertical Pin Coupler.

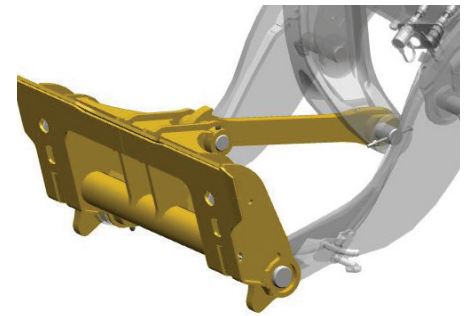

Horizontal Pin Lock (L30)

This coupler is compatible with many work tools from other manufacturers. Yields optimum performance for compatible machines due to zero offset. This optimizes the load capacity and breakout forces.

– Also known as HPL-ISO Coupler Horizontal, HPL-V, L30/L35 coupler on Cat compact wheel loaders.

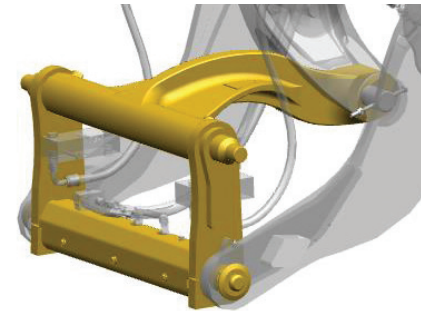

Horizontal Pin Lock-Atlas

This coupler is an evolution of the existing HPL-ISO coupler and thus has the inbuilt durability and robust design that has been in the marketplace for many years. This design gives a zero-offset coupler from the machine, similar to the HPL-ISO which optimizes the load capacity and breakout forces versus some aftermarket equipment manufacturer solutions that are less integrated.

– Also known as Atlas AR60 to AR85 or AR420 to AR480, HPL-A coupler.

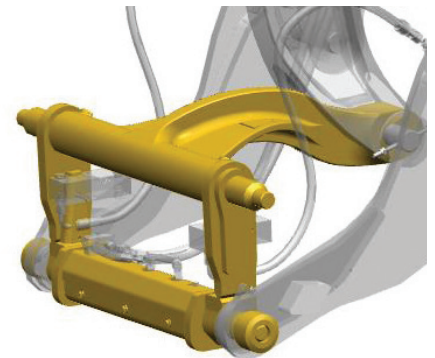

Interface Bracket Solution

Additional HPL (L35) to SSL converter bracket adds even more versatility to these machines, enabling a defined range of SSL interface attachments to be used. An easy solution to maximize machine utilization into different segments and applications.

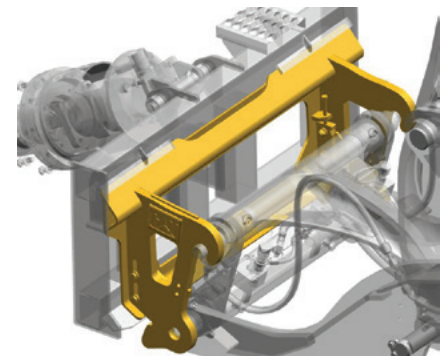

IT

Cat designed coupler for mixed fleets. Combine different machine products (backhoe loader, compact wheel loader and telehandler) with the same coupler for specific attachments. This is the optimized coupler for compact wheel loader performance.

– Also known as Integrated Tool Carrier Coupler, Standard Coupler, IT14/28.

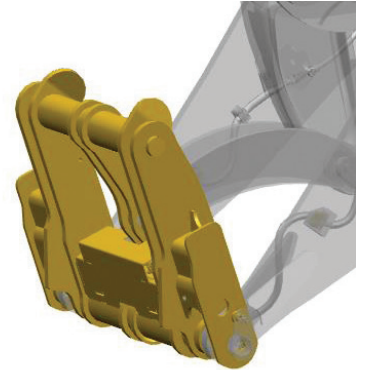

Horizontal Pin Lock – Wide (L50)

This coupler is designed to ISO 23727 international design standards. It will pick up a range of compact wheel loader attachments. It also facilitates sales of compact wheel loaders in mixed fleets. The coupler along with the profiled loader arms have been designed to give maximum visibility to the attachment, making it easier and safer to engage and disengage attachments. A simple joystick function allows for easy engagement and disengagement of the locking pins.

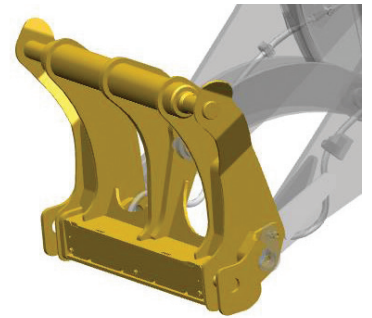

Fusion™

The Cat patented Fusion™ coupler on compact wheel loaders enables use of the Fusion range of attachments shared with the small wheel loader. Optimal visibility in combination with the machine linkage, makes it easier and safer to engage and disengage attachments. The advanced hydraulic vertical wedge lock creates a tight, rattle-free fit, eliminating play and wear resulting in a long service life.

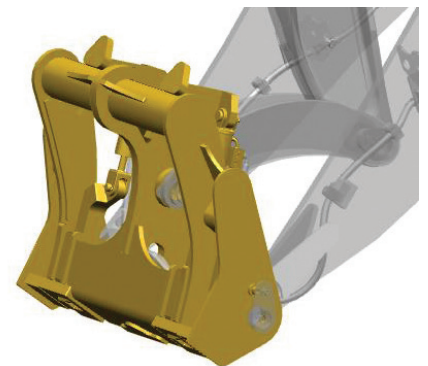

No Coupler Solution – Pin On

No coupler solution. Allows for maximum usage of machine lifting capabilities in the application. Often used when machine is 100% dedicated to the task at hand.



Choose the Right Coupler for Your Machine

903D, 906, 907, 908

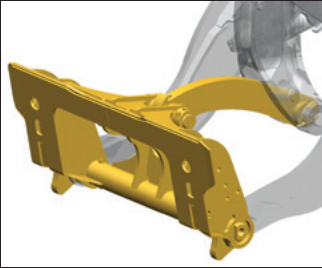

SSL Coupler
903D, 906, 907, 908

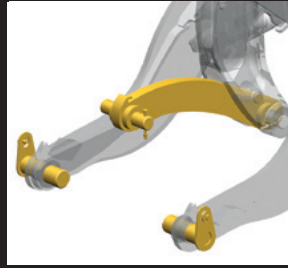

Pin On Solution
907



Horizontal Pin Lock (HPL-A)
Atlas AR60/AR85 Style
906, 907, 908

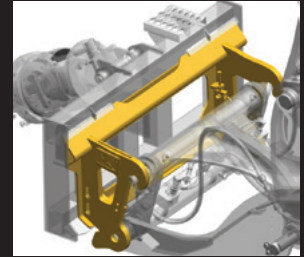

HPL (L35) to SSL
Interface Bracket Solution
906, 907, 908



Horizontal Pin Lock (HPL-V)
L30/L35 Style
906, 907, 908

910, 914, 920, 914K, 920K

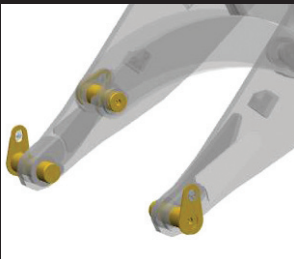

Pin On Solution
910, 914/914K, 920/920K



Fusion Coupler
914/914K, 920/920K

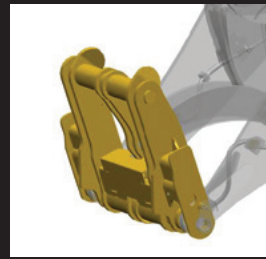

IT Coupler
910, 914/914K, 920/920K

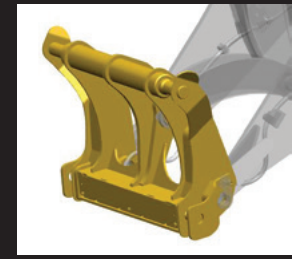

Horizontal Pin Lock
Wide (L50)
910, 914/914K, 920/920K

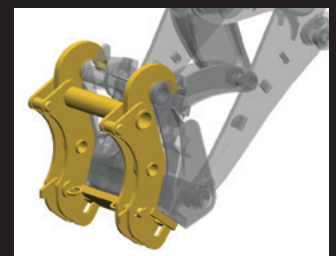

Fusion to IT
Conversion Adapter Solution
91x

Interface Bracket Solutions

Converter brackets add even more versatility to Cat compact wheel loaders, enabling a defined range of IT and SSL interface attachments to be used. Converter brackets are an easy solution to maximize machine utilization within different segments and applications.



**HPL (L35) to SSL
Adapter Interface**

ADAPTER INTERFACE, HPL (L35) TO SSL

Part Number	Weight kg (lb)	Description
471-8330*	65 (143)	Adapter Bracket
494-6852*	2 (5)	Rack Back Stop Kit
377-1579	0.5 (1)	Harness Conversion, 14 Pin to 8 Pin
371-3725	1 (3)	Kit KS, WKTL Conversion to 5-Lines

**Cannot be used with SSL buckets. Conversion kits such as rack back stop and harness are required for certain attachments. See your local Cat dealer for full details.*

CONVERSION ADAPTER (IT TO FUSION)

Part Number	Weight kg (lb)	Description
589-6664	150 (330)	Adapter interface



**Fusion to IT
Conversion Adapter**

**COMPACT WHEEL LOADERS
ATTACHMENTS**

Compact Wheel Loader
Ground Engaging Tools



Ground Engaging Tools (GET)

Cat ground engaging tools feature a variety of wear-resistant solutions to suit all applications.

GET for 903D, 906, 907, 908

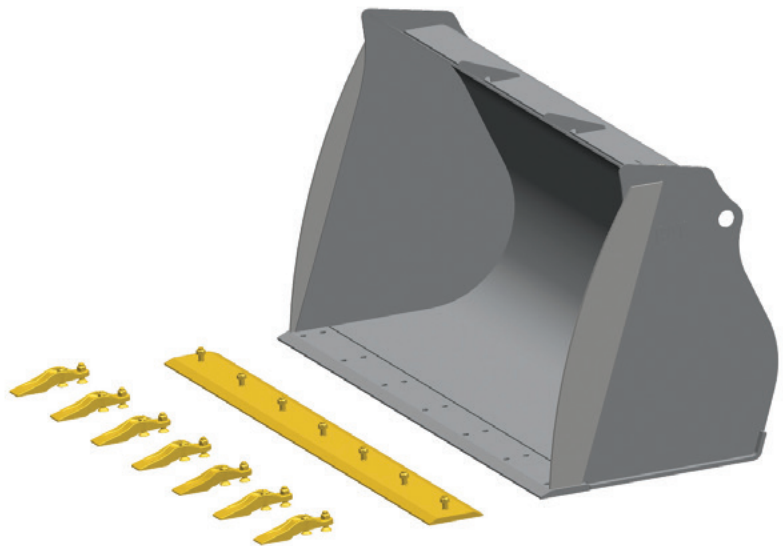

GROUND ENGAGING TOOLS (GET) – CUTTING EDGE 903D

Bucket Width mm (in)	Description	Part Number	Bolts (Qty 13)	Nuts (Qty 13)
1780 (70)	Cutting Edge, bolt-on, 1 piece	132-4723	159-2953	8T-4778
1880 (74)	Cutting Edge, bolt-on, 1 piece	132-4724	159-2953	8T-4778

GROUND ENGAGING TOOLS (GET) – CUTTING EDGE 906, 907, 908

Bucket Width mm (in)	Description	Part Number	Bolts (Qty 13)	Nuts (Qty 13)
1780 (70)	Standard Single Piece Cutting Edge	132-4723	159-2953	8T-4778
1890 (74)	Standard Single Piece Cutting Edge	132-4724	159-2953	8T-4778
2045 (80)	Standard Single Piece Cutting Edge	135-9397	159-2953	8T-4778
2080 (81)	Standard Single Piece Cutting Edge	132-4725	159-2953	8T-4778

TIPS 903D, 906, 907, 908

Part Number	Description	Bolts (Qty 7)	Nuts (Qty 7)
132-4720*	General Duty J200	246-4349	8T-4778

*No adapters required, teeth bolt directly to bucket.



COMPACT WHEEL LOADERS ATTACHMENTS

GROUND ENGAGING TOOLS (GET) – CUTTING EDGES				910, 914, 920
Bucket Width – mm (in)	2300 (91)	2400 (95)	2550 (100)	
Description	Standard Single Piece	Standard Single Piece	Standard Single Piece	
Part Number	521-8053	436-9689	494-5878	
Description	Standard 3 Piece*	Standard 3 Piece*	Standard 3 Piece*	
Center	4T-2911	9W-8620	—	
End	4T-2918 (QTY 2)	4T-2914 (QTY 2)	—	
Description	Segmented**	Segmented**	Segmented**	
Standard	128-2873 (QTY 7)	128-2873 (QTY 7)	—	
Description	Hardware	Hardware	Hardware	
Part Number	4F-7827 (Bolts – QTY 8, 14 for Segmented)	4F-7827 (Bolts – QTY 8, 14 for Segmented)	4F-7827 (Bolts – QTY 8)	
Nuts	2J-3506 (Nuts – QTY 8, 14 for Segmented)	2J-3506 (Nuts – QTY 8, 14 for Segmented)	2J-3506 (Nuts – QTY 8)	
Description	Base Edge	Base Edge	Base Edge	
Part Number	206-2366	5G-8342	492-6828	
Description	BOCE Group (1 piece)	BOCE Group (1 piece)	BOCE Group (1 piece)	
Part Number	527-8510	470-4537	494-5877	
Description	BOCE Group (3 piece)	BOCE Group (3 piece)	BOCE Group (3 piece)	
Part Number	—	9W-8618	—	
Description	Segment Group	Segment Group	Segment Group	
Part Number	—	9W-8619	—	

*Not recommended.

**For use with adapters and tips.

TIPS		910, 914, 920
Part Number	Description	
1U-3202	General Duty (Long) J200	
8E-6208	Pin	
8E-6209	Retainer	
9J-4207 (QTY 6)	Adapter (CTR)	
1U-2208	Adapter (LH)	
1U-2209	Adapter (RH)	
5J-4771 (QTY 12)	Bolt (10 × 2.75)	
6F-0196 (QTY 2)	Bolt (9 × 2.75)	
2J-3505 (QTY 2)	Nut	
2J-3506 (QTY 12)	Nut	
9W-9642	Set of 8 Bolt-on Adapters (Includes Hardware)	
100-7924	Set of 8 Long Tips (Includes Hardware)	
4T-1204	Weld On Adapter	

GET for 910, 914, 918, 920

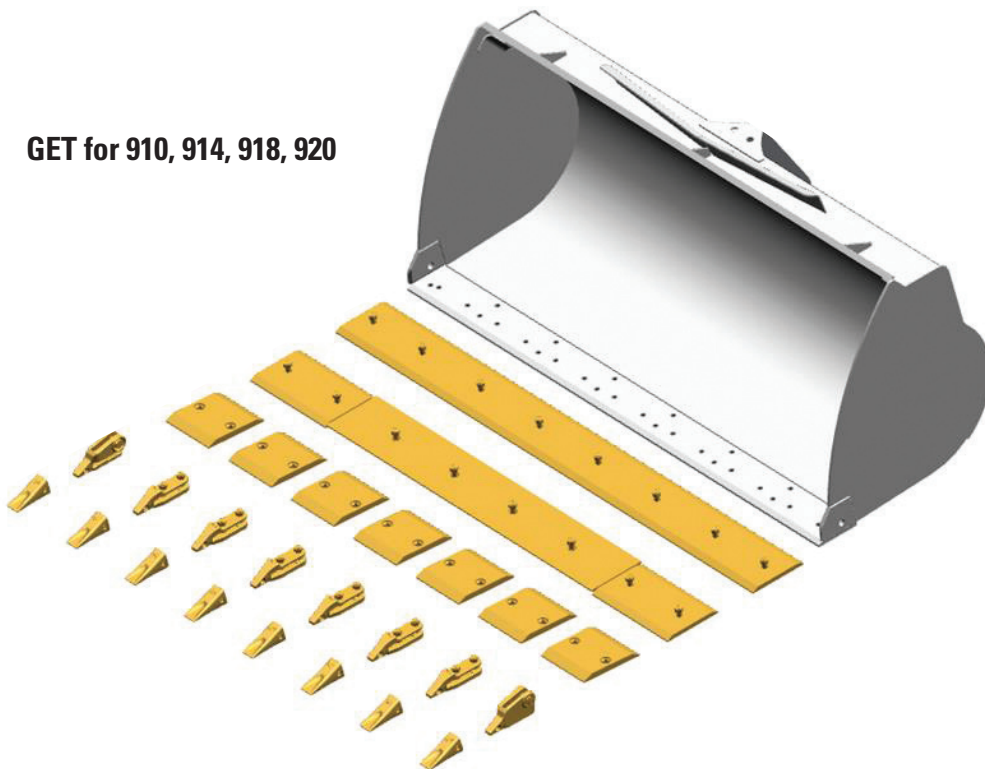

**COMPACT WHEEL LOADERS
ATTACHMENTS**



903D

NORTH AMERICA ONLY

General Purpose Buckets have been designed to optimize performance of the Cat compact wheel loader when loading, carrying, leveling, grading and dumping in a wide variety of applications and materials.



General Purpose Bucket

GENERAL PURPOSE BUCKETS						SSL
Part Number	Capacity <i>m³ (yd³)</i>	Weight <i>kg (lb)</i>	Length <i>mm (in)</i>	Width <i>mm (in)</i>	Height <i>mm (in)</i>	Edge Type
276-5715	0.6 (0.8)	311 (686)	790 (31)	1790 (71)	823 (32)	BOCE

Light Material Buckets have higher volume capacities to handle less dense materials such as topsoil, fertilizer, wood chips and much more.

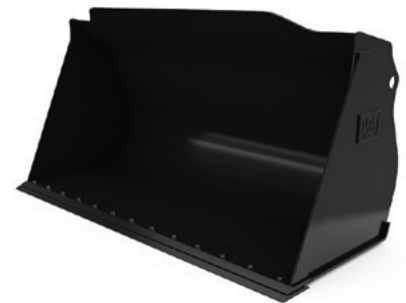

Light Material Bucket

LIGHT MATERIAL BUCKET					SSL
Part Number	Capacity <i>m³ (yd³)</i>	Weight <i>kg (lb)</i>	Length <i>mm (in)</i>	Width <i>mm (in)</i>	Height <i>mm (in)</i>
261-1368	1.0 (1.3)	391 (862)	991 (39)	1890 (74)	1003 (40)

Material Handling Buckets are designed for loading, carrying, dumping and handling light, loosely packed material in agricultural and landscaping applications.

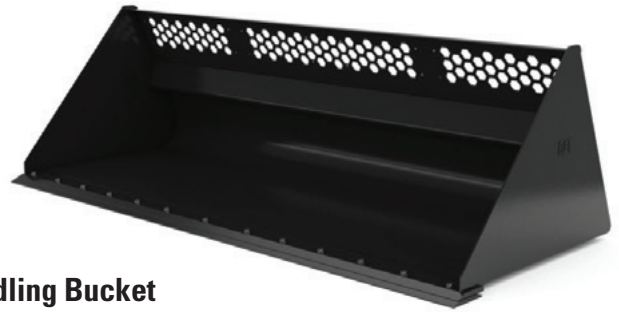

Material Handling Bucket

MATERIAL HANDLING BUCKETS						SSL
Part Number	Capacity <i>m³ (yd³)</i>	Weight <i>kg (lb)</i>	Length <i>mm (in)</i>	Width <i>mm (in)</i>	Height <i>mm (in)</i>	Edge Type
472-2546	1.07 (1.4)	365 (805)	1031 (41)	2185 (86)	757 (30)	BOCE
472-2548	1.25 (1.63)	400 (882)	1031 (41)	2490 (98)	757 (30)	BOCE
469-0774	1.33 (1.74)	418 (922)	1031 (41)	2642 (104)	757 (30)	BOCE

Pallet Fork Carriages are used for moving palletized loads on construction sites, handling bagged fertilizer and seed at landscaping and nursery sites.

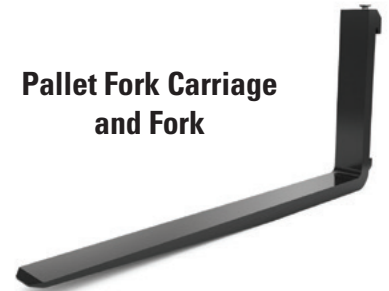

Pallet Fork Carriage and Fork

FORK CARRIAGE – PALLET					SSL
Part Number	Class	Weight <i>kg (lb)</i>	Width <i>mm (in)</i>	Length <i>mm (in)</i>	Height <i>mm (in)</i>
261-1315*	2	86 (190)	1169 (46)	235 (9.3)	488 (19)

*Requires 2× Class 2 Offset forks/tines.

FORKS – CLASS 2						
Part Number	Weight <i>kg (lb)</i>	Tine Length <i>mm (in)</i>	Overall Length <i>mm (in)</i>	Width <i>mm (in)</i>	Thickness <i>mm (in)</i>	Height <i>mm (in)</i>
195-6943*	42 (92)	914 (36)	979 (39)	100 (4)	40 (1.6)	541 (21)
195-6942*	47 (104)	1070 (42)	1139 (45)	100 (4)	40 (1.6)	541 (21)

*Order two forks for a complete set. For use with Class 2 carriage.

Explore More 903D Attachments

SKID STEER LOADER ATTACHMENTS COMPATIBLE WITH 903D

Attachment

Augers, STD Flow

Blades, Angle and Dozer

Brooms, Angle

Brooms, Utility

Brooms, Pickup

Buckets: General Purpose, Light Material,
Multi-Purpose, Industrial, Skeleton

Mixing Buckets

Cold Planers, STD Flow

Carriages and Forks

Grapple Buckets, Grapple Forks, Grapple Rakes

Landscape Rakes

Landscape Tillers

Material Handling Arms

Nursery Forks

Power Box Rakes (PR188 only)

Tree Scoop Bucket

Snow Blower (SR115 only)

Snow Plows

Stump Bucket

Stump Grinders, STD Flow

Trenchers, STD Flow

Vibratory Drum Compactors



For more skid steer loader attachments for the 903D, see the following pages for 906/907/908 models, color-coded **ORANGE** at the bottom.

Please note that some standard flow skid steer loader tools are compatible with 903D. Some attachments may need additional requirements for 903D.

Contact your Cat dealer for full details.

**COMPACT WHEEL LOADERS
ATTACHMENTS**



**COMPACT WHEEL LOADERS
ATTACHMENTS**



906, 907, 908

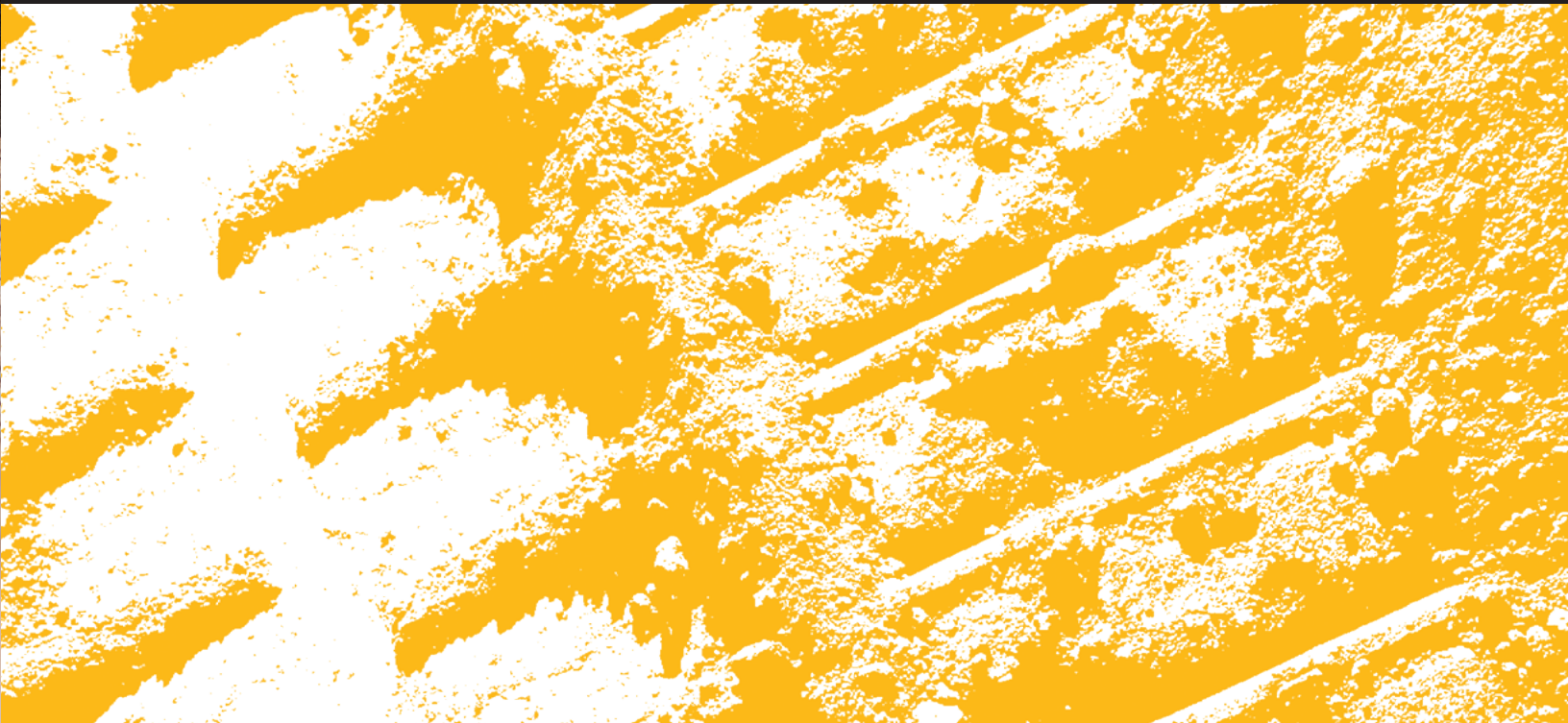

COMPACT WHEEL LOADERS ATTACHMENTS



AUGER DRIVE ASSEMBLIES

MODEL	SSL		
	A23	A41	A68
Overall Height – mm (in)	1020 (40)	934 (37)	978 (39)
Weight – kg (lb)	192 (423)	166 (366)	182 (401)
Drive Shaft Torque at Maximum Pressure – N·m (lbf)	2304 (1699)	4118 (3037)	6826 (5035)
Required Hydraulics	STD Flow	STD Flow	High Flow
Part Number	218-3178	219-7706	424-0440*

*Only compatible on the 908.

ADAPTERS AND EXTENSIONS

Adapter, Hex 50 mm (2 in) to Round 65 mm (2 9/16 in)	156-6329
Adapter, Round 65 mm (2 9/16 in) to Hex 50 mm (2 in)	217-3191
Extension, Telescoping 914 mm (3 ft)	372-0256
Extension, Telescoping 1829 mm (6 ft)	372-0257
Extension, Auger 305 mm (12 in)	156-6328
Extension, Auger 610 mm (24 in)	217-3192
Retention Pin Kit	372-0258



Retention Pin Kit

AUGER BITS – STANDARD DUTY

Diameter – mm (in)	102 (4)	152 (6)	229 (9)	305 (12)	381 (15)	457 (18)	610 (24)	762 (30)	914 (36)
Overall Length – mm (in)	1219 (48)	1238 (49)	1238 (49)	1278 (50)	1289 (51)	1278 (50)	1289 (51)	1278 (50)	1278 (50)
Weight – kg (lb)	18 (40)	23 (51)	34 (75)	46 (101)	50 (111)	65 (143)	92 (203)	128 (282)	173 (381)
Number of Teeth	pilot only	2	4	4	5	6	8	10	12
Part Number	366-7751	153-4083	153-4084	153-4085	366-7752	153-4086	153-4089	217-3194	153-4091

AUGER BITS – INDUSTRIAL

Diameter – mm (in)	152 (6)	229 (9)	305 (12)	406 (16)	457 (18)
Overall Length – mm (in)	1224 (48)	1219 (48)	1219 (48)	1221 (48)	1224 (48)
Weight – kg (lb)	26 (57)	33 (73)	41 (90)	52 (115)	49 (108)
Number of Teeth	2	4	4	6	6
Part Number	372-0260	372-0261	372-0262	372-0263	372-0264

AUGER BITS – INDUSTRIAL (CONTINUED)

Diameter – mm (in)	610 (24)	762 (30)	914 (36)	1067 (42)	1219 (48)
Overall Length – mm (in)	1219 (48)	1219 (48)	1219 (48)	1219 (48)	1220 (48)
Weight – kg (lb)	68 (150)	82 (181)	101 (223)	132 (291)	156 (344)
Number of Teeth	8	10	12	16	18
Part Number	372-0265	372-0266	372-0267	372-0268	372-0269

AUGER BITS – INDUSTRIAL ROCK

Diameter – mm (in)	152 (6)	229 (9)	305 (12)	406 (16)	457 (18)
Overall Length – mm (in)	1222 (48)	1222 (48)	1222 (48)	1221 (48)	1221 (48)
Weight – kg (lb)	36 (79)	49 (108)	61 (135)	76 (168)	87 (192)
Number of Teeth	8	10	12	15	16
Part Number	372-0270	372-0271	372-0272	372-0273	372-0274

AUGER BITS – INDUSTRIAL ROCK (CONTINUED)

Diameter – mm (in)	508 (20)	610 (24)	762 (30)	914 (36)
Overall Length – mm (in)	1221 (48)	1222 (48)	1222 (48)	1222 (48)
Weight – kg (lb)	99 (218)	128 (282)	141 (311)	186 (410)
Number of Teeth	17	20	24	26
Part Number	372-0275	372-0276	372-0277	372-0278



**Auger Bit
Standard Duty**

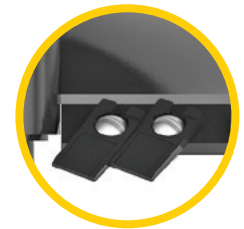

**Auger Bit
Industrial**

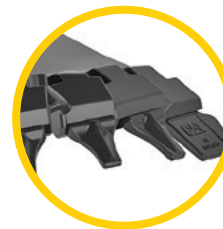

**Auger Bit
Industrial Rock**



COMPACT WHEEL LOADERS ATTACHMENTS

**Auger Bit
Tree**

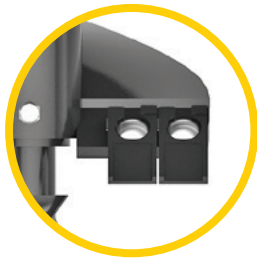

AUGER BITS – TREE

Upper Diameter – mm (in)	610 (24)	914 (36)
Lower Diameter – mm (in)	305 (12)	457 (18)
Overall Length – mm (in)	1289 (51)	1288 (51)
Weight – kg (lb)	74 (163)	140 (309)
Number of Teeth	9	13
Part Number	153-4092	153-4095



**Auger Bit
Rock Head – Bolt On**

AUGER BITS – ROCK HEAD*

Flight Diameter – mm (in)	152 (6)	229 (9)	305 (12)	380 (15)	457 (18)	610 (24)
Cut Diameter – mm (in)	190 (7.5)	266 (10.5)	342 (13.5)	419 (16.5)	495 (19.5)	647 (25.5)
Overall Length – mm (in)	238 (9)	250 (10)	250 (10)	263 (10)	276 (11)	301 (12)
Weight – kg (lb)	11 (23)	15 (33)	19 (41)	21 (47)	25 (55)	36 (79)
Number of Teeth	8	10	12	14	16	20
Part Number	372-0230	372-0231	372-0232	372-0233	372-0234	372-0235

*Bolt-on rock head used with standard flights.

REPLACEMENT TEETH AND HARDWARE (ALL AUGER BITS)*

Part Number	Description
153-4094	Standard Duty Tooth
174-9566	Hard Face Tooth (optional)
174-9567	Carbide Inserted Tooth (optional)
6V-8959	Bolt (1× required)
6V-7687	Locknut (1× required)

*Optional replacement teeth available through Parts only.

AUGER REPLACEMENT PARTS AND HARDWARE*

Part Number	Description
153-4093	Pilot Point/Bit
7X-2549	Bolt (1× required)
6V-7687	Locknut (1× required)

*Available through Parts only.

Bale Grabs safely grab, carry and place square or round baled material.



Bale Grab

Bale Spears are ideal for hay bales, both round and square as well as other baled material in agriculture applications.



Single Bale Spear

Dual Bale Spear



BALE GRABS							SSL
Part Number	Weight kg (lb)	Capacity kg (lb)	Overall Width mm (in)	Overall Depth mm (in)	Working Pressure kPa (psi)	Maximum Opening Width mm (in)	Required Hydraulics
477-9896*	261 (575)	1091 (2405)	1401 (55)	1550 (61)	21000 (3046)	1803 (71)	STD Flow
489-0075*	263 (580)	1091 (2405)	1401 (55)	1631 (64)	21000 (3046)	2133 (84)	STD Flow

*Includes hydraulic lines with 1/2 inch quick disconnects.

BALE SPEARS							SSL
Part Number	Weight kg (lb)	Capacity kg (lb)	Overall Width mm (in)	Overall Depth mm (in)	Usable Tine Length mm (in)	Tine Spacing mm (in)	Tine Configuration
475-6074	70 (154)	909 (2004)	1285 (51)	1186 (47)	890 (35)	800 (32)	Single
475-6079	72 (159)	909 (2004)	1285 (51)	1443 (57)	1140 (45)	800 (32)	Single
475-6070	118 (260)	1364 (3007)	1407 (55)	1100 (43)	890 (35)	720 (28)	Dual
475-6080	121 (267)	1364 (3007)	1407 (55)	1347 (53)	1140 (45)	720 (28)	Dual



Angle Blade

Angle Blades are useful for moving dirt, gravel, waste and more. They are ideal for finish grade work in construction, landscaping and road building applications.

ANGLE BLADES	SSL	
Cutting Edge Width – mm (in)	1893 (75)	2198 (87)
Width Fully Angled – mm (in)	1685 (66)	1949 (77)
Length – mm (in)	753 (30)	753 (30)
Weight – kg (lb)	313 (690)	331 (730)
Required Hydraulics	STD Flow	STD Flow
Part Number	177-1989	177-1990
Kit – Snow and Impact	225-9522	225-9523



Dozer Blade, 6-Way

Dozer Blades are designed for rough and finish grading in dirt, gravel and light dozing.

DOZER BLADES 6-WAY	SSL	
Cutting Edge Width – mm (in)	2007 (79)	2337 (92)
Width (Fully Angled) – mm (in)	1750 (69)	2049 (81)
Length – mm (in)	1028 (41)	1028 (41)
Weight – kg (lb)	471 (1038)	528 (1164)
Required Hydraulics	STD Flow	STD Flow
Part Number	541-0940*	541-0945*

**Requires conversion harness 377-1579 for all models except for H2/K/M with SSL quick coupler and High Flow Hydraulics.*

Angle Brooms are for clearing parking lots, industrial plants, mill yards, airport runways, streets, driveways and lanes.

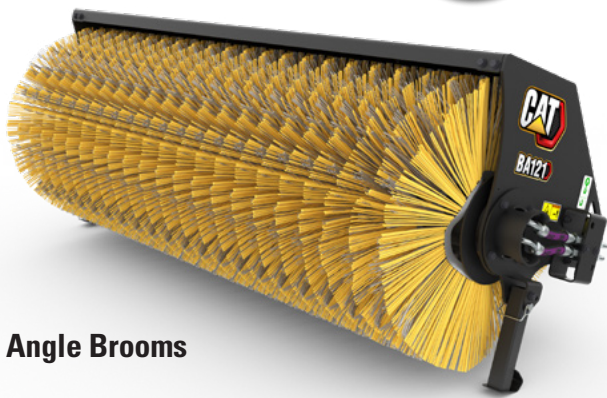

Angle Brooms



ANGLE BROOMS

SSL

MODEL	BA118	BA118	BA118	BA121	BA121	BA121
Bristle Material	Poly/Wire	Poly/Wire	Poly	Poly/Wire	Poly/Wire	Poly
Angling	Manual	Hydraulic	Hydraulic	Manual	Hydraulic	Hydraulic
Overall Width – mm (in)	2036 (80)	2036 (80)	2036 (80)	2336 (92)	2336 (92)	2336 (92)
Sweeping Width – mm (in)	1800 (71)	1800 (71)	1800 (71)	2100 (83)	2100 (83)	2100 (83)
Height – mm (in)	893 (35)	893 (35)	893 (35)	893 (35)	893 (35)	893 (35)
Length – mm (in)	1560 (61)	1560 (61)	1560 (61)	1560 (61)	1560 (61)	1560 (61)
Weight – kg (lb)	372 (820)	388 (855)	378 (833)	400 (882)	417 (919)	405 (893)
Required Hydraulics	STD Flow	STD Flow	STD Flow	STD Flow	STD Flow	STD Flow
Part Number	565-4831	565-4832	565-4833	565-4841	454-4842	565-4843

KITS

Part Number	Model	Description
618-1570	BA118	Deflector Kit
518-0083	BA121	Deflector Kit
619-4526*	BA118/BA121	Water Sprinkler Kit
564-7367	BA118/BA121	Hydraulic Conversion Kit

*Requires cab mounted water tank.

BRISTLES

BROOM	Part Number	POLY	STEEL	Cold Weather
BA118	Part Number	565-4837	565-4839	565-4838
	Quantity	19	18	19
BA121	Part Number	562-7622	562-7624	562-7623
	Quantity	22	21	22

NOTE: Cold weather bristles are blue poly.

*Part number includes quantity listed. Order two sets in any combination for a complete set.

COMPACT WHEEL LOADERS ATTACHMENTS



Pickup Brooms

Pickup Brooms collect dirt and debris from a variety of surfaces.

PICKUP BROOMS		SSL
MODEL	BP115C	BP118C
Overall Width – mm (in)	1990 (78)	2295 (90)
Sweeping Width – mm (in)	1524 (60)	1829 (72)
Height – mm (in)	872 (34)	872 (34)
Length – mm (in)	1837 (72)	1837 (72)
Weight – kg (lb)	526 (1160)	570 (1257)
Required Hydraulics	STD Flow	STD Flow
Part Number	448-5680	448-5690
Kit-Gutter Brush	452-4150	452-4150

KIT		
Part Number	Model	Description
452-4185*	BP115C/BP118C	Water sprinkler

*Requires machine control, electrical, water tank.

BRISTLES				
BROOM	Part Number	POLY	STEEL	Cold Weather
BP115C	Part Number	562-7602	562-7604	562-7603
	Quantity	18	17	18
BP118C	Part Number	562-7612	562-7614	562-7613
	Quantity	21	20	21

NOTE: Yellow poly bristles are standard. Cold weather bristles are blue poly.

*Part number includes quantity listed. Order two sets in any combination for a complete set.

COMPACT WHEEL LOADERS ATTACHMENTS



Utility Brooms

Utility Brooms sweep and collect light debris on smooth surfaces in forward or reverse travel.

UTILITY BROOMS						SSL
MODEL	BU115	BU118	BU121	BU115	BU118	BU121
Bristle Material	Poly	Poly	Poly	Poly/Wire	Poly/Wire	Poly/Wire
Overall Width – mm (in)	1810 (71)	2115 (83)	2420 (95)	1810 (71)	2115 (83)	2420 (95)
Sweeping Width – mm (in)	1500 (59)	1800 (71)	2100 (83)	1500 (59)	1800 (71)	2100 (83)
Height – mm (in)	793 (31)	793 (31)	793 (31)	793 (31)	793 (31)	793 (31)
Length – mm (in)	1530 (60)	1530 (60)	1530 (60)	1530 (60)	1530 (60)	1530 (60)
Weight – kg (lb)	430 (948)	485 (1069)	539 (1188)	433 (955)	488 (1076)	542 (1195)
Required Hydraulics	STD Flow	STD Flow	STD Flow	STD Flow	STD Flow	STD Flow
Part Number	626-4231	626-4232	626-4233	626-4234	626-4235	626-4236

BRISTLES

BROOM	Part Number	POLY	STEEL	Cold Weather
BU115	Part Number	562-7602	562-7604	562-7603
	Quantity	18	17	18
BU118	Part Number	562-7612	562-7614	562-7613
	Quantity	21	20	21
BU121	Part Number	637-4139	637-4141	637-4140
	Quantity	24	23	24

NOTE: Cold weather bristles are blue poly.

*Part number includes quantity listed. Order two sets in any combination for a complete set.

KITS

Part Number	Model	Description
623-4203*	BU115/BU118/BU121	Water Sprinkler Kit
623-4226	BU115/BU118/BU121	Gutter Brush Kit
610-5876	BU115/BU118/BU121	Water Tank Kit

Note: Water tank can be tool or cab mounted.

*Water sprinkler kit requires water tank.

COMPACT WHEEL LOADERS ATTACHMENTS



BA22
Manual Angle Broom

Angle Brooms are used for clearing parking lots, industrial plants, mill yards, airport runways, streets, driveways and lanes. 📷

ANGLE BROOMS

MODEL	BA22
Overall Width – mm (in)	2400 (95)
Sweeping Width – mm (in)	2200 (87)
Brush Diameter – mm (in)	700 (28)
Brush Material (50% Poly/50% Wire)	Yes
Height – mm (in)	1300 (51)
Length – mm (in)	1535 (60)
Weight – kg (lb)	410 (904)
Required Hydraulics	STD Flow
Part Number	600-8977*

*Requires 3rd function hydraulics and hook selection.

BRISTLES

BROOM		POLY	STEEL	SPACER
BA22	Part Number	302-8211	202-8957	421-1549
	Quantity*	28	27	54
BP22	Part Number	157-2556	—	421-1549
	Quantity*	34	—	34

*A quantity of 2 kits must be ordered for a full set.

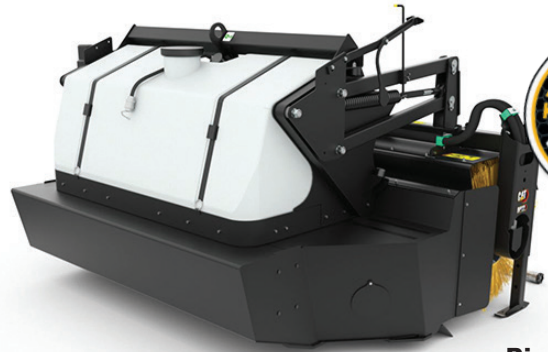

BP22
Pickup Broom

Pickup Brooms

sweep and deposit materials into an integrated hopper for easy removal and dumping. 📷

PICKUP BROOMS

MODEL	BP22
Overall Width – mm (in)	2400 (95)
Sweeping Width – mm (in)	2200 (87)
Brush Diameter – mm (in)	700 (28)
Brush Material (100% Poly)	Yes
Height – mm (in)	1300 (51)
Length – mm (in)	1830 (72)
Weight – kg (lb)	580 (1279)
Required Hydraulics	3rd Function
Part Number	600-8974

*Requires 3rd function hydraulics and hook selection.

HOOK SELECTION

MACHINE	INTERFACE	BA22	BP22
906 – 908	SSL	329-8634	—
906 – 908	HPL (L35)	—	329-8631

BROOM KITS

Part Number	Description
455-7380	Twist to connect (M45) quick disconnects for machine side.
196-4191	Quick Disconnects Kit, Push, Size 12 – Converts a machine using the nipple type quick disconnects to a machine using the flat face type quick disconnects.
497-9461	BA22/BA25 Broom Tank Kit, 105 gallons. (Requires 609-9555 spray kit, 12V/24V)
497-9457	BA22, 12V, Spray Kit – Includes water pump, filter, hoses, fixing materials and spray nozzles. (Requires 497-9461 Broom Tank Kit)
609-9555	Spray Kit – Includes water pump, filter, hoses, fixing materials and spray nozzles. (Requires 497-9461 Broom Tank Kit)
588-4294*	BP22/BP25 Rooding Kit – Locking device to prevent the broom from dropping during rooding.

*Required for rooding in certain parts of the EU. Consult dealer for clarification.

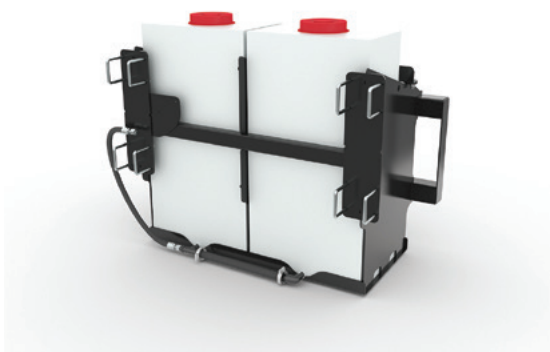

497-9461 Broom Tank Kit

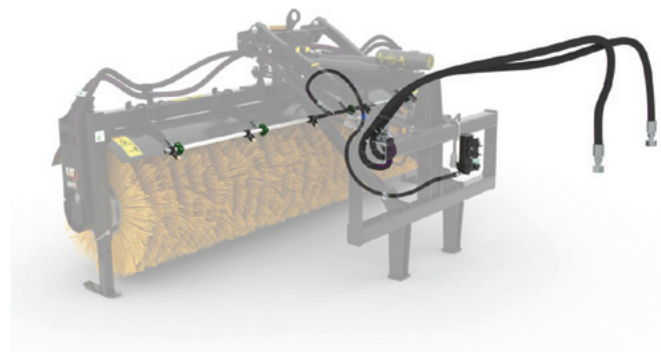

609-9555 Spray Kit

COMPACT WHEEL LOADERS ATTACHMENTS



Industrial Brushcutters are designed for land management, utilities, site prep and maintenance work for brush, small trees, and dense vegetation. These work tools bring unparalleled speed and productivity for clearing overgrowth from highway medians, utility easements and initial land clearing for housing, parks and recreational areas.

INDUSTRIAL BRUSHCUTTERS		
MODEL	BRX118	BRX318
Overall Width – mm (in)	1911 (75)	1911 (75)
Cutting Width – mm (in)	1829 (72)	1829 (72)
Maximum Cutting Diameter – mm (in)	203 (8)	203 (8)
Overall Height – mm (in)	733 (29)	733 (29)
Overall Length – mm (in)	2170 (85)	2170 (85)
Weight – kg (lb)	1072 (2363)	1072 (2363)
Required Hydraulics	STD Flow	High Flow XPS
Part Number	610-2760	610-2770



Brushcutter

General Purpose Buckets have been designed to optimize performance of the Cat compact wheel loader when loading, carrying, leveling, grading and dumping in a wide variety of applications and materials.

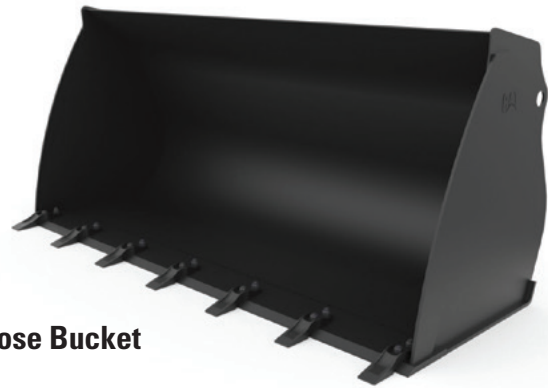

General Purpose Bucket

GENERAL PURPOSE BUCKETS							SSL
Part Number	Capacity <i>m³ (yd³)</i>	Weight <i>kg (lb)</i>	Length <i>mm (in)</i>	Width <i>mm (in)</i>	Height <i>mm (in)</i>	Optimal Compatibility	Edge Type
569-6219	0.8 (1.0)	373 (822)	855 (34)	1890 (74)	923 (36)	906, 907, 908	BOCE
569-6175	0.95 (1.2)	398 (877)	923 (36)	1890 (74)	935 (37)	906	BOCE
569-6185	0.95 (1.2)	376 (829)	993 (39)	1880 (74)	920 (36)	906	BOT
569-6178	1.05 (1.4)	416 (917)	921 (36)	2045 (81)	935 (37)	907	BOCE
569-6188	1.05 (1.4)	395 (871)	991 (39)	2036 (80)	920 (36)	907	BOT
569-6180	1.15 (1.5)	448 (988)	981 (39)	2080 (82)	954 (38)	908	BOCE
569-6190	1.15 (1.5)	422 (930)	1050 (41)	2060 (81)	940 (37)	908	BOT

GENERAL PURPOSE BUCKETS							HPL (L30)
Part Number	Capacity <i>m³ (yd³)</i>	Weight <i>kg (lb)</i>	Length <i>mm (in)</i>	Width <i>mm (in)</i>	Height <i>mm (in)</i>	Optimal Compatibility	Edge Type
569-6176	0.95 (1.2)	399 (880)	903 (36)	1890 (74)	935 (37)	906	BOCE
569-6186	0.95 (1.2)	377 (831)	972 (38)	1880 (74)	920 (36)	906	BOT
569-6179	1.05 (1.4)	417 (919)	900 (35)	2045 (81)	935 (37)	907	BOCE
569-6189	1.05 (1.4)	396 (873)	970 (38)	2036 (80)	920 (36)	907	BOT
569-6181	1.15 (1.5)	449 (990)	960 (38)	2080 (82)	954 (38)	908	BOCE
569-6191	1.15 (1.5)	423 (933)	1030 (41)	2060 (81)	940 (37)	908	BOT
569-6183	1.35 (1.8)	480 (1058)	1066 (42)	2080 (82)	985 (39)	908	BOCE
569-6193	1.35 (1.8)	454 (1001)	1136 (45)	2060 (81)	970 (38)	908	BOT

COMPACT WHEEL LOADERS ATTACHMENTS

GENERAL PURPOSE BUCKETS

HPL-A/ATLAS

Part Number	Capacity <i>m³ (yd³)</i>	Weight <i>(kg) lb</i>	Length <i>(mm) in</i>	Width <i>(mm) in</i>	Height <i>(mm) in</i>	Optimal Compatibility	Edge Type
569-6177	0.95 (1.2)	402 (886)	903 (36)	1890 (74)	935 (37)	906	BOCE
569-6187	0.95 (1.2)	380 (838)	972 (38)	1880 (74)	920 (36)	906	BOT
569-6182	1.15 (1.5)	452 (997)	960 (38)	2080 (82)	954 (38)	907	BOCE
569-6192	1.15 (1.5)	426 (939)	1030 (41)	2060 (81)	940 (37)	907	BOT
569-6184	1.35 (1.8)	484 (1067)	1067 (42)	2080 (82)	985 (39)	908	BOCE
569-6194	1.35 (1.8)	457 (1008)	1136 (45)	2060 (81)	970 (38)	908	BOT

Industrial Grapple Bucket handles bulky, irregularly shaped objects. Ideal for railroad ties, trees, large rocks, brush, industrial and demolition scrap, as well as recycling debris.

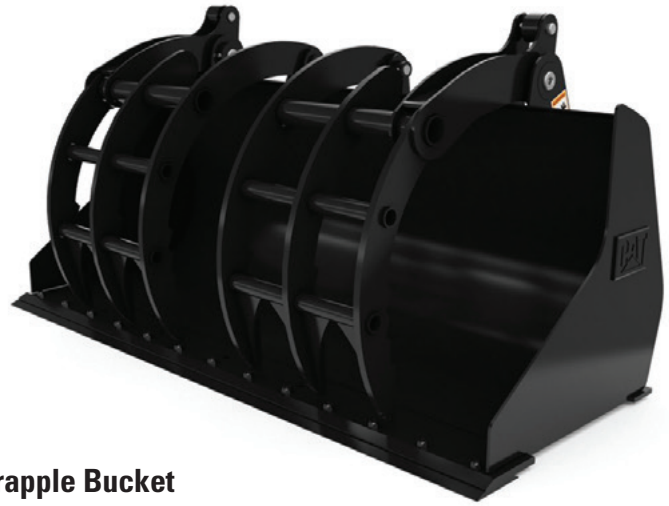

Industrial Grapple Bucket

INDUSTRIAL GRAPPLE BUCKET

SSL

Part Number	Weight <i>kg (lb)</i>	Length <i>mm (in)</i>	Width <i>mm (in)</i>	Height <i>mm (in)</i>	Jaw Opening <i>mm (in)</i>	Optimal Compatibility	Required Hydraulics	Edge Type
368-2500	587 (1295)	1028 (41)	2080 (82)	1054 (42)	1016 (40)	906, 907, 908	3rd Function	BOCE

Light Material Buckets



Light Material Buckets leverage many of the same features found in the general purpose bucket but with higher volume capacities to handle less dense materials such as topsoil, fertilizer, wood chips and many more.



Light Material Bucket

LIGHT MATERIAL BUCKETS							SSL
Part Number	Capacity <i>m³ (yd³)</i>	Weight <i>kg (lb)</i>	Length <i>mm (in)</i>	Width <i>mm (in)</i>	Height <i>mm (in)</i>	Optimal Compatibility	Edge Type
569-6215	1.25 (1.6)	466 (1027)	1035 (41)	2080 (82)	975 (38)	906, 907	BOCE
569-6217	1.55 (2.0)	520 (1146)	1205 (47)	2080 (82)	1015 (40)	908	BOCE

LIGHT MATERIAL BUCKETS						HORIZONTAL PIN LOCK (L30)	
Part Number	Capacity <i>m³ (yd³)</i>	Weight <i>kg (lb)</i>	Length <i>mm (in)</i>	Width <i>mm (in)</i>	Height <i>mm (in)</i>	Optimal Compatibility	Edge Type
569-6216	1.25 (1.6)	467 (1030)	1014 (40)	2080 (82)	975 (38)	906, 907	BOCE
569-6218	1.55 (2.0)	521 (1149)	1185 (47)	2080 (82)	1012 (40)	908	BOCE

COMPACT WHEEL LOADERS

ATTACHMENTS

Multi-Purpose Buckets have the same loading, reliability and durability characteristics as other compact wheel loader buckets, with added versatility for digging, dozing, clamping, grading and leveling in a broad range of applications.

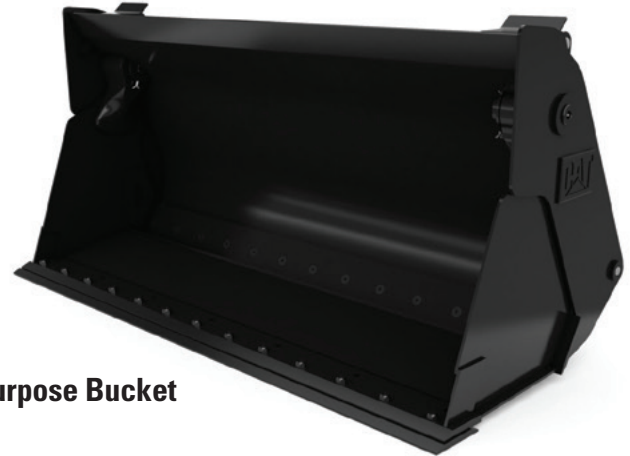

Multi-Purpose Bucket

MULTI-PURPOSE BUCKETS								SSL
Part Number	Capacity <i>m³ (yd³)</i>	Weight <i>kg (lb)</i>	Length <i>mm (in)</i>	Width <i>mm (in)</i>	Height <i>mm (in)</i>	Optimal Compatibility	Required Hydraulics	Edge Type
337-8941	0.75 (1.0)	534 (1177)	892 (35)	1890 (74)	943 (37)	906, 907	3rd Function	BOCE
337-8942	0.75 (1.0)	513 (1131)	962 (38)	1890 (74)	927 (37)	906, 907	3rd Function	BOT
337-8945	0.9 (1.2)	582 (1283)	930 (37)	2080 (82)	949 (37)	908	3rd Function	BOCE
337-8946	0.9 (1.2)	558 (1230)	1000 (39)	2080 (82)	933 (37)	908	3rd Function	BOT

MULTI-PURPOSE BUCKETS						HORIZONTAL PIN LOCK (L30)		
Part Number	Capacity <i>m³ (yd³)</i>	Weight <i>kg (lb)</i>	Length <i>mm (in)</i>	Width <i>mm (in)</i>	Height <i>mm (in)</i>	Optimal Compatibility	Required Hydraulics	Edge Type
337-8943	0.75 (1.0)	589 (1297)	904 (36)	1890 (74)	943 (37)	906, 907	3rd Function	BOCE
337-8944	0.75 (1.0)	576 (1271)	973 (38)	1880 (74)	943 (37)	906, 907	3rd Function	BOT
337-8947	0.9 (1.2)	634 (1398)	926 (37)	2080 (82)	949 (37)	908	3rd Function	BOCE
337-8948	0.9 (1.2)	634 (1398)	996 (39)	2060 (81)	933 (37)	908	3rd Function	BOT

MULTI-PURPOSE BUCKETS						HORIZONTAL PIN LOCK-ATLAS		
Part Number	Capacity <i>m³ (yd³)</i>	Weight <i>kg (lb)</i>	Length <i>mm (in)</i>	Width <i>mm (in)</i>	Height <i>mm (in)</i>	Optimal Compatibility	Required Hydraulics	Edge Type
470-4543	0.75 (0.9)	586 (1292)	916 (36)	1890 (74)	943 (37)	906, 907	3rd Function	BOCE
470-4544	0.75 (0.9)	586 (1292)	986 (39)	1890 (74)	927 (37)	906, 907	3rd Function	BOT
470-4547	0.9 (1.2)	634 (1398)	926 (37)	2060 (81)	949 (37)	908	3rd Function	BOCE
470-4548	0.9 (1.2)	634 (1398)	996 (39)	2060 (81)	933 (37)	908	3rd Function	BOT

Multi-Purpose Heavy Duty Buckets

have additional features compared to standard multi-purpose buckets. For instance, the BOCE on the dozer portion is made from additionally hardened steel compared to standard BOCE. Also, there is an adjustable rectangle profile BOCE on the rear of the clam. Additionally, these buckets have larger capacity.



Multi-Purpose Heavy Duty Bucket

MULTI-PURPOSE HEAVY DUTY BUCKETS						HORIZONTAL PIN LOCK (L30)		
Part Number	Capacity <i>m³ (yd³)</i>	Weight <i>kg (lb)</i>	Length <i>mm (in)</i>	Width <i>mm (in)</i>	Height <i>mm (in)</i>	Required Hydraulics	Compatibility	Edge Type
494-7609	0.90 (1.2)	620 (1367)	1210 (48)	1890 (74)	925 (36)	3rd Function	906, 907	BOT
492-2510	0.90 (1.2)	642 (1415)	1075 (42)	1890 (74)	948 (37)	3rd Function	906, 907	BOCE
494-7610	1.05 (1.4)	657 (1448)	1238 (49)	2080 (82)	938 (37)	3rd Function	908	BOT
492-2511	1.05 (1.4)	683 (1506)	1075 (42)	2080 (82)	954 (38)	3rd Function	908	BOCE

Concrete Slab Bucket

is specially designed for removing and carrying concrete slab sections.



Concrete Slab Bucket

CONCRETE SLAB BUCKET						SSL
Part Number	Weight <i>kg (lb)</i>	Width <i>mm (in)</i>	Overall Width <i>mm (in)</i>	Height <i>mm (in)</i>	Maximum Slab Thickness <i>mm (in)</i>	
598-2232	210 (463)	607 (24)	1150 (45)	460 (18)	202 (8)	

COMPACT WHEEL LOADERS ATTACHMENTS

Stump Bucket is specifically designed for stump removal, the long narrow design allows operators to dig closely around and underneath the root ball for quick and easy displacement. Serrated bucket edges are designed to cut through roots.



STUMP BUCKET						SSL
Part Number	Weight kg (lb)	Length mm (in)	Height mm (in)	Working Width mm (in)	Overall Width mm (in)	Number of Teeth
599-4825	162 (357)	1496 (59)	526 (21)	300 (12)	1168 (46)	3

Mixing Buckets utilize a paddle auger and hydraulically controlled chute door to mix material in a variety of applications.



Mixing Bucket



MIXING BUCKETS			SSL
MODEL	MB200	MB250	
Capacity – m ³ (yd ³)	0.2 (0.26)	0.25 (0.33)	
Overall Width – mm (in)	1602 (63)	1605 (63)	
Height – mm (in)	731 (29)	877 (35)	
Length – mm (in)	694 (27)	814 (32)	
Weight – kg (lb)	290 (639)	430 (948)	
Required Hydraulics	STD Flow	STD Flow	
Part Number	489-2150	489-2200	



Side Discharge Buckets collect and discharge sawdust, mulch, straw and sand into barns, stalls and orchards, backfill topsoil or pea gravel into trenches and spread silage. The left or right discharge design eliminates the need for awkward maneuvering, saving time. 📷 (Sawdust only)

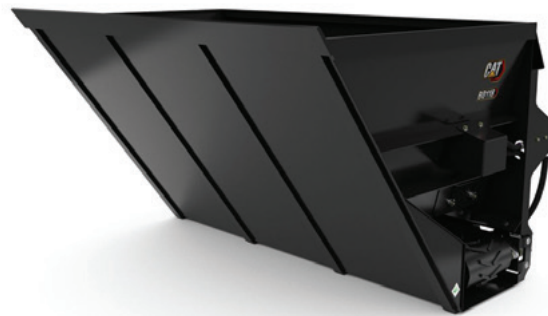
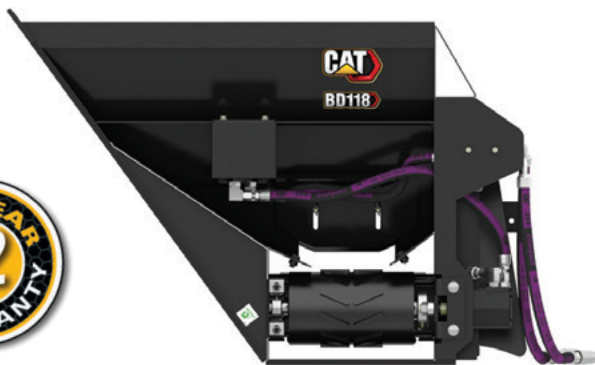

SIDE DISCHARGE BUCKETS

SSL

MODEL	BD118 SAWDUST	BD121 SAWDUST	BD118 SAND	BD121 SAND
Width – mm (in)	1860 (73)	2165 (85)	1860 (73)	2165 (85)
Capacity – m ³ (yd ³)	1.53 (2.0)	1.78 (2.3)	0.76 (1.0)	1.0 (1.3)
Height – mm (in)	1118 (44)	1118 (44)	867 (34)	867 (34)
Length – mm (in)	1451 (57)	1451 (57)	1269 (50)	1269 (50)
Weight – kg (lb)	535 (1180)	579 (1277)	480 (1058)	522 (1151)
Required Hydraulics	STD Flow	STD Flow	STD Flow	STD Flow
Part Number	477-9895*	479-8085*	479-8095	479-8105

COMPACT WHEEL LOADERS ATTACHMENTS

Cold Planers are designed for small paving jobs in residential and commercial applications and are primarily used to economically restore asphalt and concrete surfaces.

COLD PLANERS				SSL
MODEL	PC104	PC105	PC305	PC306
Working Width – mm (in)	350 (14)	450 (18)	450 (18)	600 (24)
Overall Width – mm (in)	1728 (68)	1728 (68)	1858 (73)	1858 (73)
Overall Length – mm (in)	1117 (44)	1182 (47)	1248 (49)	1248 (49)
Overall Height – mm (in)	941 (37)	928 (37)	930 (37)	930 (37)
Maximum Cutting Depth – mm (in)	150 (6)	150 (6)	170 (7)	170 (7)
Required Hydraulics	STD Flow	STD Flow	High Flow	High Flow
Weight – kg (lb)	682 (1504)	739 (1629)	848 (1870)	956 (2108)
Part Number	529-5760	529-5770	529-5780*	529-5790*

COLD PLANERS (CONTINUED)		SSL
MODEL	PC306 Water	PC310
Working Width – mm (in)	600 (24)	1000 (39)
Overall Width – mm (in)	1858 (73)	1858 (73)
Overall Length – mm (in)	1432 (56)	1125 (44)
Overall Height – mm (in)	930 (37)	935 (37)
Maximum Cutting Depth – mm (in)	170 (7)	130 (5)
Required Hydraulics	High Flow	High Flow
Weight – kg (lb)	1218 (2685)	1040 (2293)
Part Number	529-5791*	529-5820*

*Please contact your Cat dealer for more information on work tool performance.



Cold Planer

KITS – WATER TANK

Part Number	Description	Compatibility
591-0703*	PC42 Gallon	PC104, PC105, PC305, PC306, PC310

*Requires water spray kit, 231-2590, 231-2591 or 591-0710.

KITS – WATER SPRAY

Part Number	Description	Compatibility
231-2590*	PCX03/4/5; 2 sprinkler heads	PC104, PC205, PC305
231-2591*	PCX06/8; 3 sprinkler heads	PC306
591-0710*	PC310; 4 sprinkler heads	PC310

*Requires control work tool, electrical and integrated/machine-mounted water tank.

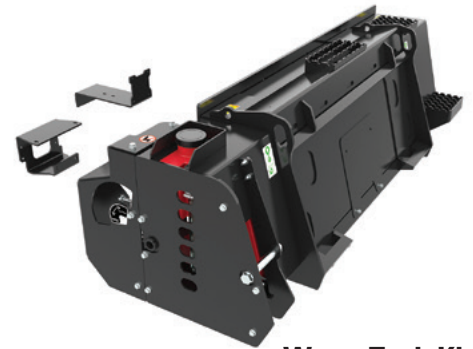

Water Tank Kit

COLD PLANER DRUMS

Part Number	Description/Width mm (in)	Cut Depth Minimum mm (in)	Cut Depth Maximum mm (in)	Bits	Optimal Compatibility
231-2572	Asphalt – (75) 3	50 (2)	200 (8)	24	PC104, PC105
231-2573	Asphalt – (150) 6	50 (2)	200 (8)	24	PC104, PC105
231-2575	Asphalt – (300) 12	50 (2)	200 (8)	42	PC104, PC105
231-2580	Asphalt – (80) 3	50 (2)	200 (8)	24	PC305, PC306
231-2581	Asphalt – (150) 6	50 (2)	200 (8)	28	PC305, PC306
606-2524	Asphalt – (300) 12	50 (2)	200 (8)	36	PC104, PC105
231-2583	Asphalt – (300) 12	50 (2)	200 (8)	42	PC306
224-7360	Asphalt – (450) 18	0 (0)	150 (6)	48	PC105
231-2586	Asphalt – (450) 18	50 (2)	200 (8)	48	PC306
224-7384	Asphalt – (600) 24	0 (0)	170 (7)	60	PC306
467-8067	Fine Tooth Kit – (450) 18	0 (0)	30 (1.2)	208	PC105
467-8068	Fine Tooth Kit – (600) 24	0 (0)	30 (1.2)	308	PC306
467-8069	Fine Tooth Kit – (1000) 40	0 (0)	30 (1.2)	508	PC310



Cold Planer Drum

COMPACT WHEEL LOADERS ATTACHMENTS

Pallet Fork Carriages and Forks are used for moving palletized loads on construction sites, handling bagged fertilizer and seed at landscaping and nursery sites.

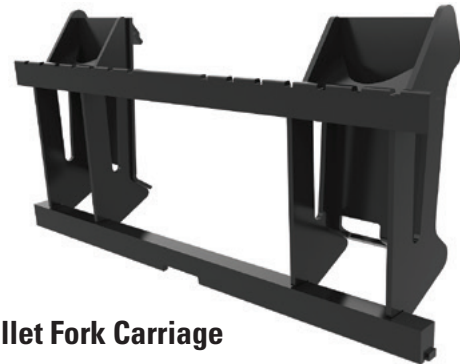

SSL Pallet Fork Carriage

PALLET FORK CARRIAGE					SSL
Part Number	Weight kg (lb)	Width mm (in)	Height mm (in)	Optimal Compatibility	Class
261-1350*	113 (249)	1312 (52)	550 (22)	906, 907	2
583-3909*	110 (242)	1312 (52)	634 (25)	908	3

*Requires 2 forks of same class.

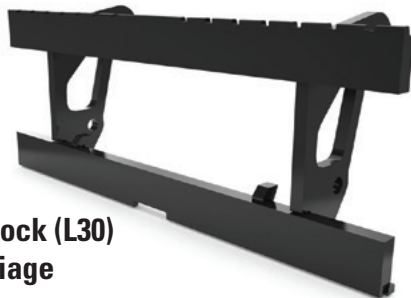

**Horizontal Pin Lock (L30)
Pallet Fork Carriage**

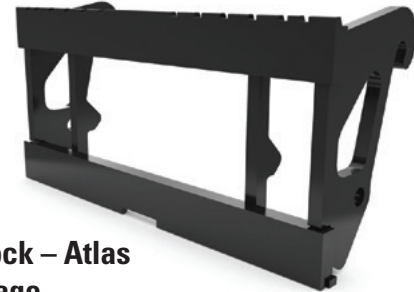

**Horizontal Pin Lock – Atlas
Pallet Fork Carriage**

PALLET FORK CARRIAGE				HORIZONTAL PIN LOCK (L30)	
Part Number	Weight kg (lb)	Width mm (in)	Height mm (in)	Optimal Compatibility	Class
260-1716*	82 (181)	1312 (52)	493 (19)	906, 907	2
261-1413*	122 (269)	1312 (52)	519 (20)	908	3

*Requires 2 forks of same class.

PALLET FORK CARRIAGE				HORIZONTAL PIN LOCK – ATLAS	
Part Number	Weight kg (lb)	Width mm (in)	Height mm (in)	Optimal Compatibility	Class
463-9907*	79 (174)	1042 (41)	493 (19)	906, 907	2
463-9902*	112 (247)	1042 (41)	519 (20)	908	3

*Requires 2 forks of same class.

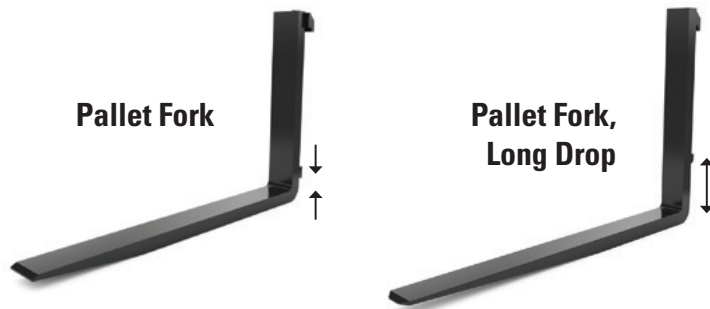

PALLET FORKS

Part Number	Weight kg (lb)	Tine Length mm (in)	Overall Length mm (in)	Width mm (in)	Thickness mm (in)	Height mm (in)	Class
149-7665*	50 (110)	1120 (44)	1194 (47)	100 (4)	50 (2)	541 (21)	2
195-8545*	52 (114)	1220 (48)	1289 (51)	100 (4)	40 (1.6)	541 (21)	2
161-2437*	51 (112)	1220 (48)	1294 (51)	100 (4)	45 (1.8)	541 (21)	2
138-8896*	61 (134)	1120 (44)	1205 (47)	100 (4)	50 (2)	651 (26)	3
202-5483*	65 (142)	1220 (48)	1305 (51)	100 (4)	50 (2)	651 (26)	3
583-3908*#	118 (260)	1220 (48)	1289 (51)	100 (4)	40 (1.6)	690 (27)	2
368-2610*#	71 (157)	1219 (48)	1299 (51)	100 (4)	50 (2)	829 (33)	3

*Order two forks for a complete set.
#Long Drop. Hook type, pull retention.

PALLET FORK CARRIAGE (HEAVY DUTY)

SSL

Part Number	Weight kg (lb)	Width mm (in)	Height mm (in)	Optimal Compatibility	Class
532-7810*	145 (320)	1438 (57)	910 (36)	906, 907	2

PALLET FORKS (HEAVY DUTY)

Part Number	Weight kg (lb)	Tine Length mm (in)	Overall Length mm (in)	Width mm (in)	Thickness mm (in)	Height mm (in)	Class
540-1431	118 (260)	1067 (42)	1141 (45)	122 (4.8)	45 (1.8)	549 (22)	2
540-1432	132 (291)	1219 (48)	1293 (51)	122 (4.8)	45 (1.8)	549 (22)	2
540-1433	158 (348)	1524 (60)	1598 (63)	122 (4.8)	45 (1.8)	549 (22)	2

KIT – HYDRAULIC POSITIONER

SSL

Part Number	Description	Compatibility
556-3173*	Adds hydraulic adjustability to fork tines	For use with heavy duty carriage 532-7810

*Not available in the EU.

Hydraulic
Positioner Kit



COMPACT WHEEL LOADERS ATTACHMENTS

Material Handling Arm is a useful tool for virtually all types of applications, including industrial, construction and agricultural, to pick, carry and load a variety of materials and equipment.

MATERIAL HANDLING ARM	SSL
Overall Height – mm (in)	1473 (58)
Overall Width – mm (in)	1316 (52)
Retracted Length – mm (in)	1016 (40)
Maximum Horizontal Reach – mm (in)	2134 (84)
Maximum Load Rating – kg (lb)	907 (2000)
Weight – kg (lb)	127 (280)
Part Number	216-8756



Material Handling Arm

Landscape Tillers level terrain and break up soil, mixing compost and other materials into existing soil.



Landscape Tiller

LANDSCAPE TILLERS	SSL	
MODEL	LT114	LT118
Working Width – mm (in)	1354 (53)	1848 (73)
Working Depth – mm (in)	152 (6)	152 (6)
Overall Width – mm (in)	1789 (70)	2272 (89)
Length – mm (in)	956 (38)	956 (38)
Height – mm (in)	755 (30)	755 (30)
Weight – kg (lb)	340 (750)	420 (926)
Required Hydraulics	STD Flow	STD Flow
Part Number	219-7165	219-0426

LANDSCAPE RAKES		SSL
MODEL	LR116	LR119
Working Width – mm (in)	1576 (62)	1883 (74)
Raking Width – mm (in)	1384 (55)	1665 (66)
Overall Width – mm (in)	1683 (66)	1990 (78)
Height – mm (in)	989 (39)	989 (39)
Length – mm (in)	1620 (64)	1620 (64)
Weight – kg (lb)	595 (1312)	653 (1440)
Required Hydraulics	STD Flow	STD Flow
Part Number	224-9220	224-9221

Landscape Rakes scarify soil and collect debris for easy removal.



Landscape Rake



COMPACT WHEEL LOADERS ATTACHMENTS



Power Box Rake

Power Box Rakes are designed for clearing and preparing soil in landscape finishing applications.

POWER BOX RAKES			SSL		
MODEL – Future	PR118	PR118	PR121	PR121	PR123
Angle Control	MANUAL	HYDRAULIC	MANUAL	HYDRAULIC	HYDRAULIC
Overall Width – mm (in)	2057 (81)	2057 (81)	2362 (93)	2362 (93)	2515 (99)
Raking Width at Maximum Angle – mm (in)	1727 (68)	1727 (68)	2007 (79)	2007 (79)	2159 (85)
Overall Height – mm (in)	847 (33)	847 (33)	847 (33)	847 (33)	953 (38)
Weight – kg (lb)	408 (900)	427 (941)	465 (1025)	483 (1065)	606 (1336)
Required Hydraulics	STD Flow	STD Flow	STD Flow	STD Flow	STD Flow
Part Number	608-0655	608-0650	608-0665	608-0660	608-0670

Nursery Forks are designed to allow pivoting one fork out for gained maneuverability and handling capabilities in nursery and landscaping applications. Fork tines can be configured with a manually adjusted fork or hydraulically side shifting fork to give greater flexibility when handling multiple or different sized root balls.



Nursery Forks

NURSERY FORKS		SSL
MODEL	Manual	Hydraulic
Overall Height – mm (in)	1427 (56)	1427 (56)
Weight – kg (lb)	338 (745)	358 (789)
Usable Tine Length – mm (in)	1788 (70)	1788 (70)
Fork Opening Maximum at Tip (Angled) – mm (in)	1196 (47)	1196 (47)
Fork Opening Parallel Maximum – mm (in)	617 (24)	617 (24)
Maximum Root Ball Diameter – mm (in)	1372 (54)	1372 (54)
Required Hydraulics	STD Flow	STD Flow
Part Number	604-9810	604-9820*

**Requires 14 pin work tool harness.*

**COMPACT WHEEL LOADERS
ATTACHMENTS**



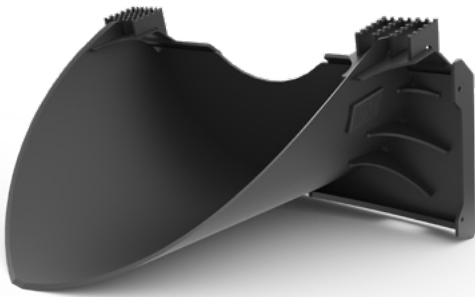

Tree Scoop Buckets are ideal for removal or planting all types of trees and shrubs at nursery sites or in landscaping applications. The spade profile can easily cut through the ground while maintaining a safe buffer zone around the plant roots, making transplanting easy.

SCOOP BUCKET

SSL

Part Number	Weight kg (lb)	Length mm (in)	Overall Width mm (in)	Height mm (in)	Working Width mm (in)
604-4903	143 (314)	983 (39)	1148 (45)	594 (23)	920 (36)

COMPACT WHEEL LOADERS ATTACHMENTS

Snow Blowers are designed for removing snow from streets, parking lots, driveways and sidewalks, making them ideal for various winter cleanup and maintenance applications. 📷



Snow Blower

SNOW BLOWERS					SSL
MODEL	SR115	SR118	SR121	SR318	SR321
Intake Width – mm (in)	1290 (51)	1614 (64)	1942 (77)	1614 (64)	1942 (77)
Cutting Height – mm (in)	867 (34)	867 (34)	867 (34)	867 (34)	867 (34)
Maximum Throw – m (ft)	12 (40)	12 (40)	12 (40)	12 (40)	12 (40)
Overall Width – mm (in)	1572 (62)	1877 (74)	2181 (86)	1877 (74)	2181 (86)
Overall Height – mm (in)	1843 (73)	1843 (73)	1843 (73)	1843 (73)	1843 (73)
Overall Length – mm (in)	951 (37)	951 (37)	951 (37)	951 (37)	951 (37)
Weight – kg (lb)	463 (1021)	478 (1054)	501 (1105)	495 (1091)	518 (1142)
Required Hydraulics	STD Flow	STD Flow	STD Flow	HF XPS	HF XPS
Part Number	580-0607*	546-4485*	545-8977*	546-4509*	546-4504*

*Requires work tool electrical control.

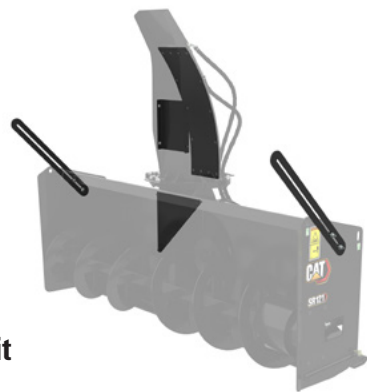

Snow Performance Kit

KIT		
Part Number	Description	Compatibility
546-4522	Snow Performance – 2 side cutters, 1 partial impeller/fan cover, 1 chute front plate, 1 chute non-metallic liner and fixing materials.	All new design snow blowers
599-0316	Truck Chute – Converts existing chute to improve height and distance of thrown snow.	SR318, SR321 Gen 3



Truck Chute Kit

Multi V-Plows have two independently operating blades that can hydraulically angle into five different blade configurations to move snow with maximum efficiency and power.

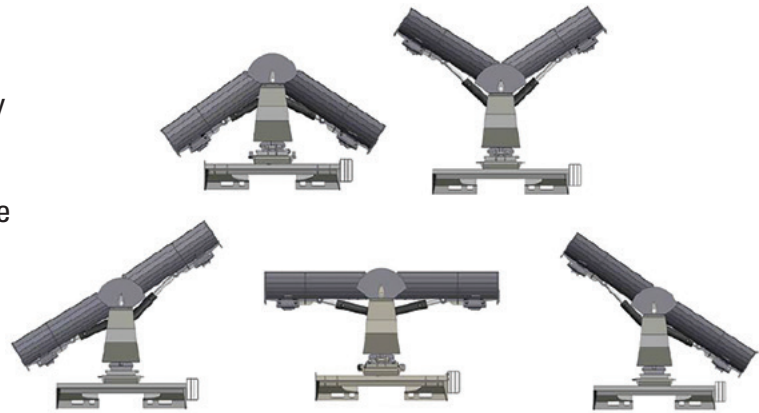

MULTI V-PLOWS		SSL
MODEL	1.5 m (5 ft)	2.1 m (7 ft)
Straight Width – mm (in)	1524 (60)	2134 (84)
Length – mm (in)	1320 (52)	1320 (52)
Overall Height – mm (in)	826 (33)	826 (33)
Weight – kg (lb)	290 (639)	426 (939)
Required Hydraulics	STD Flow	STD Flow
Part Number	542-7309	542-7310



Snow Multi V-Plow

Snow Wings have independently controlled wings and angling capability, the attachment can be configured to suit the needs of any job.

SNOW WINGS		SSL
MODEL	2.4 m (8 ft)	2.8 m (9 ft)
Working Width (Wings Open) – mm (in)	4106 (162)	4411 (174)
Working Width (Wings Closed) – mm (in)	2451 (97)	2756 (109)
Overall Height – mm (in)	915 (36)	915 (36)
Length – mm (in)	1705 (67)	1705 (67)
Weight – kg (lb)	867 (1911)	885 (1951)
Wing Rotation	180°	180°
Angling – Left /Right of Center	35°	35°
Required Hydraulics	STD Flow	STD Flow
Part Number	608-7779	608-7780

Note: Requires work tool harness and wiring (377-1579).



Snow Wing

COMPACT WHEEL LOADERS ATTACHMENTS

Cat Compact Wheel Loader Snow Plows



SNOW PLOWS					SSL
MODEL	1.8 m (6 ft)	2.1 m (7 ft)	2.4 m (8 ft)	2.7 m (9 ft)	3 m (10 ft)
Width – mm (in)	1826 (72)	2134 (84)	2435 (96)	2743 (108)	3045 (120)
Overall Height – mm (in)	800 (32)	800 (32)	800 (32)	800 (32)	800 (32)
Blade Height – mm (in)	797 (31)	797 (31)	797 (31)	797 (31)	797 (31)
Length – mm (in)	1247 (49)	1247 (49)	1247 (49)	1247 (49)	1247 (49)
Weight – kg (lb)	450 (992)	477 (1052)	502 (1107)	527 (1162)	552 (1217)
Required Hydraulics	STD Flow	STD Flow	STD Flow	STD Flow	STD Flow
Part Number	481-3666	481-3667	481-3668	481-3669	481-3670

Snow Plows offer a robust design for moving snow with maximum efficiency and power.

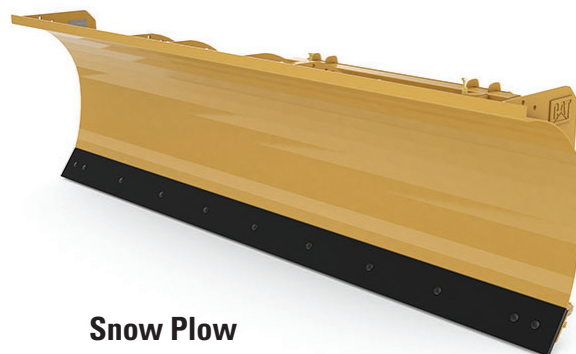

Snow Plow

Straight Snow Pushes unique design efficiently removes snow minimizing passes and reducing salt build up.



Snow Push

STRAIGHT SNOW PUSHES					SSL
MODEL	2.44 m (8 ft)	2.44 m (8 ft)	2.44 m (8 ft)	3.05 m (10 ft)	3.05 m (10 ft)
Working Width – in (mm)	2438 (96)	2438 (96)	2438 (96)	3048 (120)	3048 (120)
Overall Width – in (mm)	2553 (101)	2553 (101)	2553 (101)	3162 (125)	3162 (125)
Trip Edge Height – in (mm)	—	119 (4.7)	119 (4.7)	119 (4.7)	119 (4.7)
Overall Height – in (mm)	914 (36)	994 (39)	994 (39)	914 (36)	854 (34)
Length – in (mm)	1109 (44)	1143 (45)	1143 (45)	1109 (44)	1143 (45)
Weight – lb (kg)	353 (778)	470 (1036)	491 (1083)	393 (866)	523 (1153)
Trip Edge Type	Rubber	Rubber	Steel	Rubber	Rubber
Cutting Edge	—	489-3913	489-3921	—	482-1496
Trip Edge	No	Yes	Yes	No	Yes
Part Number	509-3705	479-8115	479-8120	509-3706	479-8086

STRAIGHT SNOW PUSHES (CONTINUED)					SSL
MODEL	3.05 m (10 ft)	3.66 m (12 ft)	3.66 m (12 ft)	3.66 m (12 ft)	
Working Width – in (mm)	3048 (120)	3658 (144)	3658 (144)	3658 (144)	
Overall Width – in (mm)	3162 (125)	3772 (149)	3772 (149)	3772 (149)	
Trip Edge Height – in (mm)	119 (4.7)	—	119 (4.7)	119 (4.7)	
Overall Height – in (mm)	854 (34)	914 (36)	994 (34)	994 (34)	
Length – in (mm)	1143 (45)	1109 (44)	1143 (45)	1143 (45)	
Weight – lb (kg)	545 (1202)	432 (952)	611 (1347)	636 (1402)	
Trip Edge Type	Steel	Rubber	Rubber	Steel	
Cutting Edge	482-7668	—	489-3929	489-3927	
Trip Edge	Yes	No	Yes	Yes	
Part Number	479-8096	509-3707	479-8089	479-8099	

COMPACT WHEEL LOADERS ATTACHMENTS

Back Drag Edges add versatility to your Cat snow push for even more efficiency.

BACK DRAG EDGES – SNOW PUSH			SSL
MODEL	2.5 m (8 ft)	3.1 m (10 ft)	3.7 m (12 ft)
Steel Edge	481-3680	481-3686	481-3689
Rubber Edge	481-3675	481-3676	481-3679

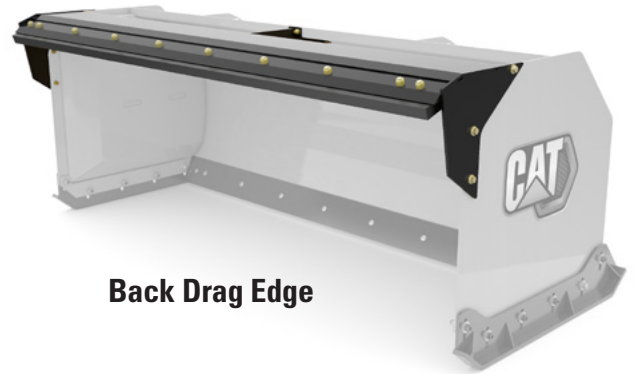

Back Drag Edge



Stump Grinders are designed to economically remove stumps in residential, commercial and agricultural settings.



Stump Grinder

STUMP GRINDERS		SSL
MODEL	SG16	
Cutting Depth (below ground) – mm (in)	521 (21)	
Cutting Height (above ground) – mm (in)	470 (19)	
Overall Height – mm (in)	730 (29)	
Overall Length – mm (in)	1737 (68)	
Overall Width – mm (in)	1175 (46)	
Weight – kg (lb)	379 (836)	
Required Hydraulics	STD Flow	
Part Number	424-0461	

COMPACT WHEEL LOADERS ATTACHMENTS

Trenchers are designed for cutting narrow straight trenches in the soil prior to laying electrical, telephone and cable lines or water and gas pipe. Trenchers are ideal for residential, commercial, agricultural, building construction, lawn care and golf course maintenance.



Standard

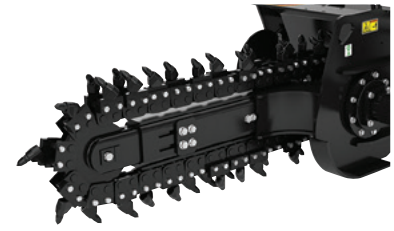

Rockfrost



Combo



Terminator

TRENCHERS							SSL
MODEL	T109	T109	T109	T109	T112	T112	T112
Side Shift Control	Manual	Hydraulic	Manual	Hydraulic	Manual	Hydraulic	Hydraulic
Cutting Width – mm (in)	152 (6)	152 (6)	203 (8)	203 (8)	152 (6)	152 (6)	203 (8)
Overall Width – mm (in)	1426 (56)	1426 (56)	1426 (56)	1426 (56)	1901 (75)	1901 (75)	1901 (75)
Overall Length – mm (in)	2348 (92)	2348 (92)	2348 (92)	2348 (92)	2705 (107)	2705 (107)	2705 (107)
Overall Height – mm (in)	786 (31)	786 (31)	786 (31)	786 (31)	786 (31)	786 (31)	786 (31)
Side Shift Travel – mm (in)	419 (17)	419 (17)	419 (17)	419 (17)	559 (22)	559 (22)	559 (22)
Standard Boom Length – mm (in)	914 (36)	914 (36)	914 (36)	914 (36)	1219 (48)	1219 (48)	1219 (48)
Weight* – kg (lb)	459 (1012)	488 (1076)	466 (1028)	495 (1092)	488 (1076)	509 (1121)	538 (1186)
Required Hydraulics	STD Flow	STD Flow	STD Flow	STD Flow	STD Flow	STD Flow	STD Flow
With Chain							
Standard*	261-4806	261-4859	261-8557	261-8558	233-2346	241-4252	241-4253
Combo	261-8559	261-8560	—	—	233-2350	241-4254	—
Rockfrost	261-8561	261-8562	—	—	241-4251	241-4255	—
Terminator	261-8563	261-8564	—	—	—	—	—

* Weight with Standard Chain.

TRENCHERS (CONTINUED)		SSL	
MODEL	T315	T315	
Side Shift Control	Hydraulic	Hydraulic	
Cutting Width – mm (in)	152 (6)	203 (8)	
Overall Width – mm (in)	1901 (75)	1901 (75)	
Overall Length – mm (in)	3010 (119)	3010 (119)	
Overall Height – mm (in)	786 (31)	786 (31)	
Side Shift Travel – mm (in)	559 (22)	559 (22)	
Standard Boom Length – mm (in)	1524 (60)	1524 (60)	
Weight – kg (lb)	550 (1212)	584 (1287)	
Required Hydraulics	High Flow*	High Flow*	
With Chain			
Standard	424-0471	424-0472	
Combo	424-0473	—	

*Please contact your Cat dealer for more information on work tool performance.

Crumber Arm

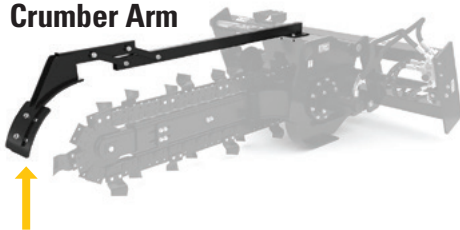

Crumber Arm Shoe

Crumber Arm and Skid Shoes

ensure smooth trench bottom following chain teeth. Formed skid shoes serve as pivot point and maintain proper spoil auger orientation.

TRENCHER CRUMBER ARMS

MODEL	T109	T112	T315
Part number	264-5714*	264-7601*	264-7602*

*Requires 264-7597 or 264-7598 shoe.

CRUMBER ARM SHOES

Shoe	152 mm/202 mm (6 in/8 in)	254 mm/305 mm (10 in/12 in)
Part Number	264-7597	264-7598

TRENCHER CHAINS ONLY			
MODEL	T109	T109	T109
Size – mm (in)	152 (6)	203 (8)	254 (10)
Standard	259-0312	258-8644	263-3431
Combo	261-4860	—	—
Rockfrost	261-4805	—	—
Terminator	243-6349	—	—
50/50 Conical	—	—	—

TRENCHER CHAINS ONLY (CONTINUED)				
MODEL	T109	T112	T112	T112
Size – mm (in)	305 (12)	152 (6)	203 (8)	254 (10)
Standard	263-3430	189-5956	222-7916	208-2678
Combo	—	222-7742	—	—
Rockfrost	—	222-7743	—	—
Terminator	—	262-7624	—	—
Combo Carbide	—	—	208-2694	—
Combo Conical	—	208-2690	208-2693	—

TRENCHER CHAINS ONLY (CONTINUED)			
MODEL	T315	T315	T315
Size – mm (in)	152 (6)	203 (8)	254 (10)
Standard	189-5957	222-8523	208-2679
Combo	222-7747	—	—
Rockfrost	208-2697	—	—
Terminator	262-7623	—	—
Combo Carbide	—	208-2699	—
Combo Conical	208-2695	208-2698	—



Vibratory Drum Compactor

Vibratory Drum Compactors are used for compacting soil, sand or gravel prior to pouring concrete or laying asphalt surfaces. Also ideal for asphalt patch work.

VIBRATORY DRUM COMPACTORS			SSL
MODEL	CV117	CV119	
Drum Width – mm (in)	1676 (66)	1854 (73)	
Overall Width – mm (in)	1854 (73)	2032 (80)	
Weight – kg (lb)	936 (2064)	970 (2139)	
Required Hydraulics	STD Flow	STD Flow	
Part Number	231-8600	231-8601	



Wheel Saws are designed for high performance trench cutting on a variety of hard or compact surfaces such as asphalt, reinforced concrete, and rocky or frozen ground.



WHEEL SAW – 908 ONLY	SSL
MODEL	SW345-80
Overall Width – mm (in)	1655 (65)
Wheel Width – mm (in)	80 (3)
Overall Height – mm (in)	1455 (57)
Length – mm (in)	2165 (85)
Weight – kg (lb)	1126 (2482)
Maximum Cutting Depth – mm (in)	450 (18)
Required Hydraulics	High Flow*
Trench Cleaning Device	No
Part Number	529-5880

**Please contact your Cat dealer for more information on work tool performance.*



Wheel Saw

NOTE: Does not meet EU visibility requirements with a camera; not for use in territories/regions that need to meet ISO5006.

Contact your dealer for assistance to gain ISO5006 compliance.

**COMPACT WHEEL LOADERS
ATTACHMENTS**



**910, 914, 920
914K, 920K**

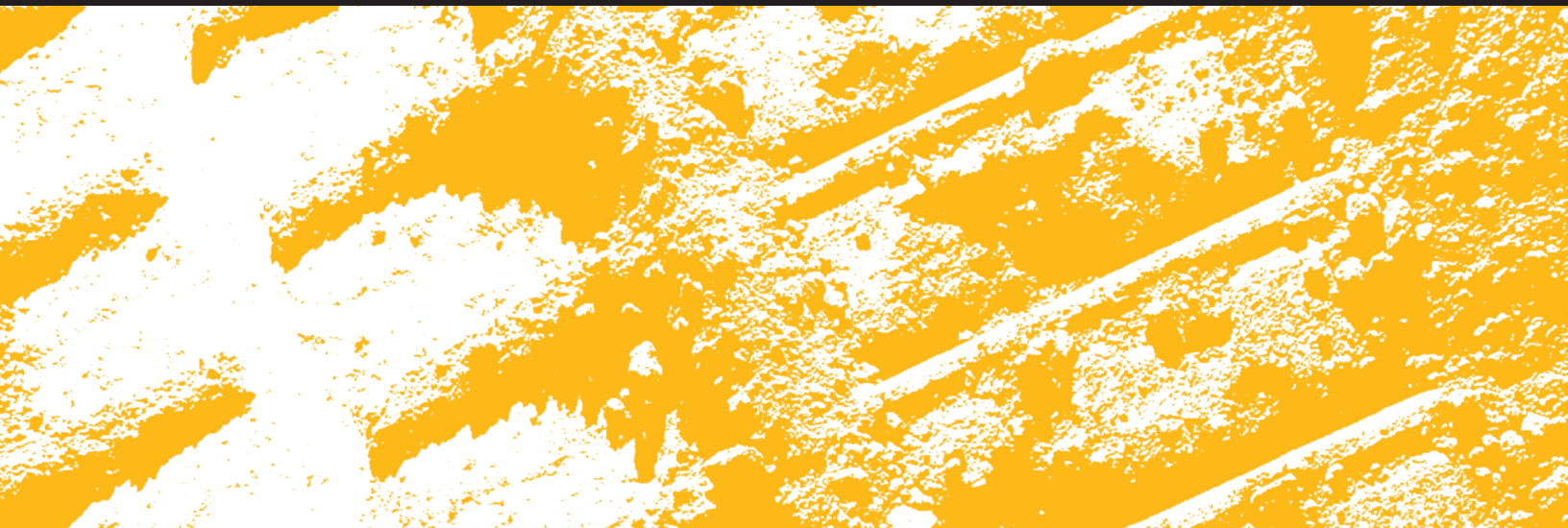

Adapter Hooks

Weld-on conversion hooks. Applicable for attachment modifications allowing connection to IT couplers or picking up IT tools on fusion couplers.

HOOKS (FOR CONVERSION TO FUSION)		
Part Number	Weight kg (lb)	Description
371-2400	150 (330)	Flat back
317-5562	357 (787)	Blank

HOOKS (FOR USE WITH VERTICAL WEDGE LOCK COUPLERS)		
Part Number	Weight kg (lb)	Description
498-4390	224 (493)	Blank, VWL, 4"

HOOKS (FOR CONVERSION TO IT COUPLER)		
Part Number	Weight kg (lb)	Description
109-6712	73 (161)	Blank, IT
113-2677	32 (70)	Flat back, IT

HOOKS (FOR USE WITH SW2003/6 COUPLERS)		
Part Number	Weight kg (lb)	Description
201-1397	69 (152)	Flat back, SA02003/6



Hook, Blank, IT



**Hook, Blank, IT
(Flat Back)**

**COMPACT WHEEL LOADERS
ATTACHMENTS**



Compact Wheel Loader
Angle Brooms



**BA25
Manual Angle Broom**

Angle Brooms are used for clearing parking lots, industrial plants, mill yards, airport runways, streets, driveways and lanes.

ANGLE BROOMS		
MODEL	BA25	BA25
Overall Width – mm (in)	2700 (106)	2700 (106)
Sweeping Width – mm (in)	2500 (98)	2500 (98)
Brush Diameter – mm (in)	700 (28)	700 (28)
Brush Material (50% Poly/50% Wire)	Yes	Yes
Height – mm (in)	1300 (51)	1300 (51)
Length – mm (in)	1535 (60)	1535 (60)
Weight – kg (lb)	430 (948)	440 (970)
Angling	Manual	Hydraulic
Part Number	600-8979*	600-8980*

*Requires 3rd function hydraulics and hook selection.

HOOK SELECTION		
MACHINE	INTERFACE	BA25
910 – 920	IT (IT14/28)	487-8490
910 – 920	HPL-Wide (L50)	487-8480
920	FUSION	497-9469

BRISTLES		SWL		
BROOM		POLY	STEEL	SPACER
BA25	Part Number	302-8211	202-8957	421-1549
	Quantity*	28	27	54

*Quantities are number needed to complete one set of mixed (poly/steel) bristles.

COMPACT WHEEL LOADERS ATTACHMENTS

Pickup Brooms sweep and deposit materials into an integrated hopper for easy removal and dumping. 



**BP25
Pickup Broom**

PICKUP BROOMS	
MODEL	BP25
Overall Width – mm (in)	2700 (106)
Sweeping Width – mm (in)	2500 (98)
Brush Diameter – mm (in)	700 (28)
Brush Material (100% Poly)	Yes
Height – mm (in)	1300 (51)
Length – mm (in)	1830 (72)
Weight – kg (lb)	650 (1433)
Required Hydraulics	3rd Function
Part Number	600-8976

**Requires 3rd function hydraulics and hook selection.*

HOOK SELECTION		
MACHINE	INTERFACE	BP25
910 – 920	IT (IT14/28)	487-8490
910 – 920	HPL-Wide (L50)	487-8480
920	FUSION	497-9469

BRISTLES		SWL		
BROOM		POLY	STEEL	SPACER
BP25	Part Number	157-2556	—	421-1549
	Quantity*	34	—	34

**Quantities are number needed to complete one set of bristles per broom model.*

BROOM KITS

Part Number	Description
455-7380	Twist to connect (M45) quick disconnects for machine side.
196-4191	Quick Disconnects Kit, Push, Size 12 – Converts a machine using the nipple type quick disconnects to a machine using the flat face type quick disconnects.
609-9555	BA22/BA25 Spray Kit – Includes water pump, filter, hoses, fixing materials and spray nozzles. (Requires 497-9461 Broom Tank Kit)
497-9461	BA22/BA25 Broom Tank Kit, 105 gallons (Requires 609-9555 spray kit, 12V/24V)
269-9333	BA25 Shield Extension – Spray protection for BA25.
588-4294*	BP22/BP25 Roding Kit – Locking device to prevent the broom from dropping during roading.

*Required for roading in certain parts of the EU. Consult dealer for clarification.

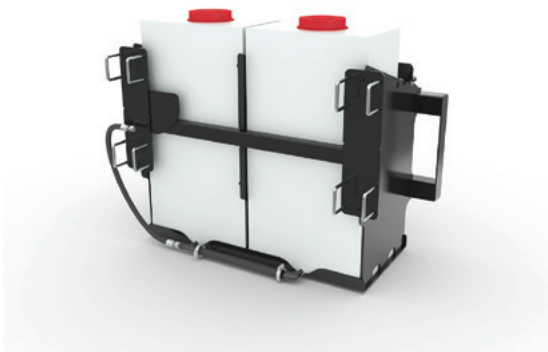

497-9461 Broom Tank Kit

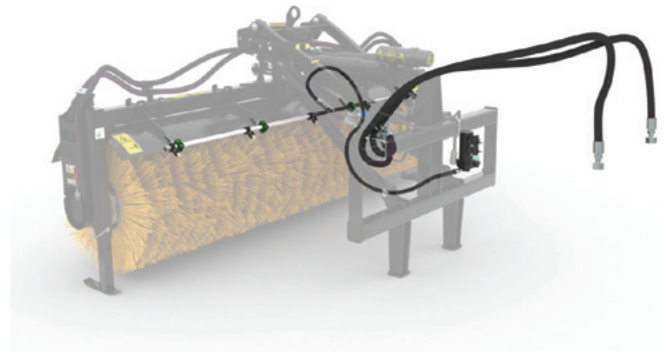

609-9555 Spray Kit

**Flat Floor
Performance Series Buckets**

incorporate a specially designed long floor and a rear cutting edge to provide optimum results and productivity when performing light grading or back-dragging, all while retaining the premium loading characteristics of the performance series.



**Horizontal Pin Lock – Wide (L50)
Flat Floor – Performance Series Bucket**

FLAT FLOOR – PERFORMANCE SERIES BUCKETS				HORIZONTAL PIN LOCK – WIDE (L50)		
Part Number	Capacity <i>m³ (yd³)</i>	Weight <i>kg (lb)</i>	Length <i>mm (in)</i>	Width <i>mm (in)</i>	Height <i>mm (in)</i>	Edge Type
488-7005	1.5 (2.0)	676 (1490)	1146 (45)	2434 (96)	1073 (42)	WOT
468-4749	1.6 (2.1)	677 (1492)	1051 (41)	2401 (95)	1080 (43)	BOCE
488-7006	1.6 (2.1)	625 (1378)	1181 (47)	2434 (96)	1023 (40)	WOT
468-4750	1.7 (2.2)	692 (1525)	1084 (43)	2401 (95)	1080 (43)	BOCE
468-4751	1.9 (2.5)	651 (1436)	1156 (46)	2401 (95)	1159 (46)	BOCE
488-7007	1.8 (2.4)	676 (1490)	1253 (49)	2434 (96)	1152 (45)	WOT



General Purpose Performance

Series Bucket design balances the bucket shape against the machine's linkage, weight, lift and tilt capacities. Benefits of a longer floor, open throat and rounded sidebars increase rack back angles for perfect material loading and increase fill factors up to 115% on top of the specified capacities.



**IT
General Purpose –
Performance Series Bucket**



**Pin On
General Purpose –
Performance Series Bucket**

GENERAL PURPOSE – PERFORMANCE SERIES BUCKETS						IT
Part Number	Capacity <i>m³ (yd³)</i>	Weight <i>kg (lb)</i>	Length <i>mm (in)</i>	Width <i>mm (in)</i>	Height <i>mm (in)</i>	Edge Type
472-6534	1.3 (1.7)	554 (1221)	1020 (40)	(2401) 95	1080 (43)	BOCE
481-9755	1.2 (1.6)	512 (1129)	1125 (44)	(2429) 96	1093 (43)	BOT
472-6539	1.5 (2.0)	574 (1265)	1100 (43)	(2401) 95	1080 (43)	BOCE
481-9760	1.4 (1.8)	532 (1173)	1205 (47)	(2429) 96	1093 (43)	BOT
472-6541	1.6 (2.1)	618 (1362)	1134 (45)	(2401) 95	1080 (43)	BOCE
481-9762	1.5 (2.0)	567 (1250)	1238 (49)	(2429) 96	1093 (43)	BOT
390-8219	1.7 (2.2)	632 (1393)	1172 (46)	(2401) 95	1159 (46)	BOCE
481-9764	1.6 (2.1)	590 (1301)	1275 (50)	(2428) 96	1163 (46)	BOT
492-2491	1.9 (2.5)	667 (1470)	1241 (49)	(2401) 95	1159 (46)	BOCE

GENERAL PURPOSE – PERFORMANCE SERIES BUCKETS						PIN ON
Part Number	Capacity <i>m³ (yd³)</i>	Weight <i>kg (lb)</i>	Length <i>mm (in)</i>	Width <i>mm (in)</i>	Height <i>mm (in)</i>	Edge Type
472-6537	1.4 (1.8)	579 (1276)	1023 (40)	2401 (95)	1080 (43)	BOCE
481-9759	1.3 (1.7)	537 (1184)	1130 (45)	2429 (96)	1093 (43)	BOT
472-6542	1.6 (2.1)	609 (1342)	1099 (43)	2401 (95)	1080 (43)	BOCE
481-9763	1.5 (2.0)	576 (1270)	1203 (47)	2429 (96)	1093 (43)	BOT
415-5961	1.8 (2.4)	658 (1451)	1171 (46)	2401 (95)	1161 (46)	BOCE
481-9766	1.7 (2.2)	616 (1358)	1276 (50)	2428 (96)	1171 (46)	BOT
415-5927	1.9 (2.5)	675 (1488)	1205 (47)	2401 (95)	1161 (46)	BOCE
481-9767	1.8 (2.4)	634 (1398)	1310 (52)	2428 (96)	1171 (46)	BOT
591-1472*	2.0 (2.6)	712 (1570)	—	2388 (94)	—	BOT

*For use with pin-on and only for machines with 20.5" tires.

COMPACT WHEEL LOADERS ATTACHMENTS



**Horizontal Pin Lock – Wide (L50)
General Purpose – Performance Series Bucket**



**Fusion
General Purpose –
Performance Series Bucket**

GENERAL PURPOSE – PERFORMANCE SERIES BUCKETS				HORIZONTAL PIN LOCK – WIDE (L50)		
Part Number	Capacity <i>m³ (yd³)</i>	Weight <i>kg (lb)</i>	Length <i>mm (in)</i>	Width <i>mm (in)</i>	Height <i>mm (in)</i>	Edge Type
472-6535	1.3 (1.7)	572 (1261)	969 (38)	2401 (95)	1080 (43)	BOCE
481-9756	1.2 (1.6)	530 (1169)	1074 (42)	2429 (96)	1093 (43)	BOT
472-6540	1.5 (2.0)	592 (1305)	1049 (41)	2401 (95)	1080 (43)	BOCE
481-9761	1.4 (1.8)	550 (1213)	1155 (46)	2429 (96)	1093 (43)	BOT
415-5957	1.7 (2.2)	650 (1433)	1121 (44)	2401 (95)	1159 (46)	BOCE
481-9765	1.6 (2.1)	608 (1341)	1225 (48)	2428 (96)	1171 (46)	BOT
492-2492	1.9 (2.5)	667 (1470)	1190 (47)	2401 (95)	1159 (46)	BOCE

GENERAL PURPOSE – PERFORMANCE SERIES BUCKETS						FUSION
Part Number	Capacity <i>m³ (yd³)</i>	Weight <i>kg (lb)</i>	Length <i>mm (in)</i>	Width <i>mm (in)</i>	Height <i>mm (in)</i>	Edge Type
550-3488	1.5 (1.9)	657 (1448)	1106 (44)	2401 (95)	1082 (43)	BOCE
559-5194	1.5 (1.9)	596 (1314)	1207 (48)	2428 (96)	1088 (43)	BOT
550-3489	1.6 (2.1)	673 (1484)	1141 (45)	2401 (95)	1082 (43)	BOCE
559-5195	1.6 (2.1)	612 (1349)	1242 (49)	2428 (96)	1089 (43)	BOT
546-4012	1.7 (2.2)	689 (1519)	1114 (44)	2401 (95)	1250 (49)	BOCE
549-6912	1.6 (2.1)	647 (1426)	1230 (48)	2435 (96)	1277 (50)	BOT
546-4014	2.0 (2.6)	734 (1618)	1186 (47)	2401 (95)	1304 (51)	BOCE
549-6913	1.9 (2.5)	734 (1618)	1302 (51)	2435 (96)	1331 (52)	BOT

High Dump Buckets feature an increased dump height over ordinary buckets for better truck loading, feeding compactors or just working the pile. Dedicated and protected dumping cylinders with a bottom hinge roll out material. Rounded sidebars provide higher fill factors and material retention in load and carry applications. 📷



HIGH DUMP BUCKETS – 914K/914, 920K/920							IT
Part Number	Capacity <i>m³ (yd³)</i>	Weight <i>kg (lb)</i>	Length <i>mm (in)</i>	Width <i>mm (in)</i>	Height <i>mm (in)</i>	Required Hydraulics	Edge Type
583-3598	2.1 (2.7)	1432 (3157)	1645 (65)	2366 (93)	1472 (58)	3rd Function	BOCE
583-3597	2.5 (3.3)	1470 (3241)	1698 (67)	2366 (93)	1583 (62)	3rd Function	BOT

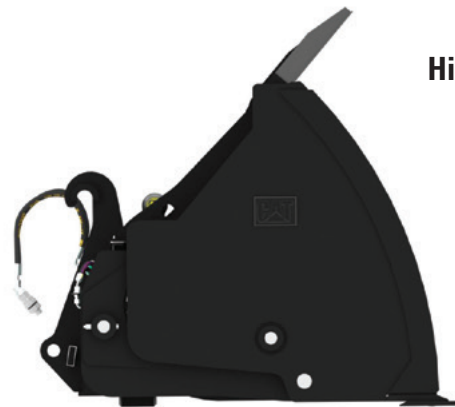

High Dump Bucket

HIGH DUMP BUCKETS – 914K/914, 920K/920				HORIZONTAL PIN LOCK – WIDE (L50)			
Part Number	Capacity <i>m³ (yd³)</i>	Weight <i>kg (lb)</i>	Length <i>mm (in)</i>	Width <i>mm (in)</i>	Height <i>mm (in)</i>	Required Hydraulics	Edge Type
579-5824	2.1 (2.7)	1434 (3161)	1622 (64)	2366 (93)	1472 (58)	3rd Function	BOCE
579-5823	2.5 (3.3)	1472 (3245)	1675 (66)	2366 (93)	1583 (62)	3rd Function	BOCE

Light Material Performance Series Buckets

leverage many of the same features found in the general purpose performance series buckets, but with higher volume capacities to handle less dense materials such as topsoil, fertilizer, wood chips and many more. Fill factors can be increased up to 115% on top of the specified capacities.



IT
Light Material – Performance Series Bucket

LIGHT MATERIAL – PERFORMANCE SERIES BUCKETS						IT
Part Number	Capacity <i>m³ (yd³)</i>	Weight <i>kg (lb)</i>	Length <i>mm (in)</i>	Width <i>mm (in)</i>	Height <i>mm (in)</i>	Edge Type
498-0031	2.5 (3.3)	793 (1748)	1427 (56)	2549 (100)	1267 (50)	BOCE
498-0034	3.0 (3.9)	854 (1883)	1517 (60)	2549 (100)	1404 (55)	BOCE
498-0037	3.5 (4.6)	915 (2017)	1647 (65)	2549 (100)	1486 (59)	BOCE



Pin On
Light Material – Performance Series Bucket

LIGHT MATERIAL – PERFORMANCE SERIES BUCKETS						PIN ON
Part Number	Capacity <i>m³ (yd³)</i>	Weight <i>kg (lb)</i>	Length <i>mm (in)</i>	Width <i>mm (in)</i>	Height <i>mm (in)</i>	Edge Type
498-0033	2.5 (3.3)	816 (1799)	1443 (57)	2549 (100)	1267 (50)	BOCE
498-0036	3.0 (3.9)	878 (1936)	1533 (60)	2549 (100)	1404 (55)	BOCE
498-0039	3.5 (4.6)	938 (2068)	1663 (66)	2549 (100)	1486 (59)	BOCE



**Horizontal Pin Lock – Wide (L50)
Light Material – Performance Series Bucket**

LIGHT MATERIAL – PERFORMANCE SERIES BUCKETS				HORIZONTAL PIN LOCK – WIDE (L50)		
Part Number	Capacity <i>m³ (yd³)</i>	Weight <i>kg (lb)</i>	Length <i>mm (in)</i>	Width <i>mm (in)</i>	Height <i>mm (in)</i>	Edge Type
498-0032	2.5 (3.3)	804 (1773)	1467 (58)	2549 (100)	1267 (50)	BOCE
498-0035	3.0 (3.9)	866 (1909)	1472 (58)	2549 (100)	1404 (55)	BOCE
498-0038	3.5 (4.6)	926 (2042)	1602 (63)	2549 (100)	1486 (59)	BOCE



**Fusion
Light Material – Performance Series Bucket**

LIGHT MATERIAL – PERFORMANCE SERIES BUCKETS						FUSION
Part Number	Capacity <i>m³ (yd³)</i>	Weight <i>kg (lb)</i>	Length <i>mm (in)</i>	Width <i>mm (in)</i>	Height <i>mm (in)</i>	Edge Type
560-0128	2.5 (3.3)	816 (1799)	1381 (54)	2549 (100)	1267 (50)	BOCE
560-0129	3.0 (3.9)	884 (1949)	1471 (58)	2549 (100)	1402 (55)	BOCE
560-0130	3.5 (4.6)	944 (2081)	1601 (63)	2549 (100)	1483 (58)	BOCE

Extreme Duty and Heavy Duty Multi-Purpose Buckets offer excellent versatility by enabling one work tool to do the job of many. This bucket is ideal for material handling, clamping, grading, leveling and grasping irregularly shaped objects.



Multi-Purpose Extreme Duty Bucket



Multi-Purpose Heavy Duty Bucket

MULTI-PURPOSE BUCKETS								IT
Part Number	Capacity <i>m³ (yd³)</i>	Weight <i>kg (lb)</i>	Length <i>mm (in)</i>	Width <i>mm (in)</i>	Height <i>mm (in)</i>	Required Hydraulics	Designation	Edge Type
506-1011	1.34 (1.75)	1169 (2577)	1262 (50)	2457 (97)	1054 (42)	3rd Function	Extreme Duty	BOCE
506-1010	1.34 (1.75)	1095 (2414)	1072 (42)	2457 (97)	1054 (42)	3rd Function	Heavy Duty	BOCE

KIT – LINES, MULTI-PURPOSE	
Part Number	Description
590-1140	For use with multi-purpose buckets to connect hydraulics.

Pallet Fork Carriages and Forks are used for moving palletized loads on construction sites, handling bagged fertilizer and seed at landscaping and nursery sites.



IT Pallet Fork Carriage

FORK CARRIAGE – PALLET					IT
Part Number	Class	Weight kg (lb)	Width kg (in)	Length kg (in)	Height kg (in)
390-8288*	3	245 (539)	1550 (61)	332 (13)	935 (37)

**Requires 2x Class 3 Offset forks/tines.*

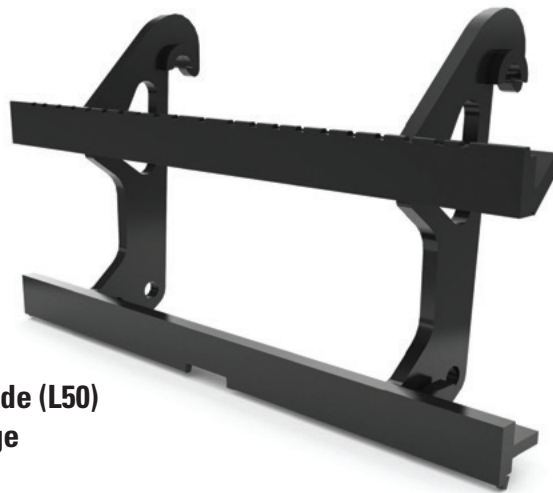

**Horizontal Pin Lock – Wide (L50)
Pallet Fork Carriage**

FORK CARRIAGE – PALLET			HORIZONTAL PIN LOCK – WIDE (L50)		
Part Number	Class	Weight kg (lb)	Width kg (in)	Length kg (in)	Height kg (in)
428-2109*	3	243 (536)	1550 (61)	428 (17)	837 (33)

**Requires 2x Class 3 Offset forks/tines.*

COMPACT WHEEL LOADERS ATTACHMENTS



Fusion Pallet Fork Carriage

FORK CARRIAGE – PALLET – 920K/920 ONLY					FUSION
Part Number	Class	Weight kg (lb)	Width mm (in)	Length mm (in)	Height mm (in)
532-8222*	3/4	712 (1570)	1566 (62)	610 (24)	1006 (40)

*Requires 2x Class 3/4 forks/tines.

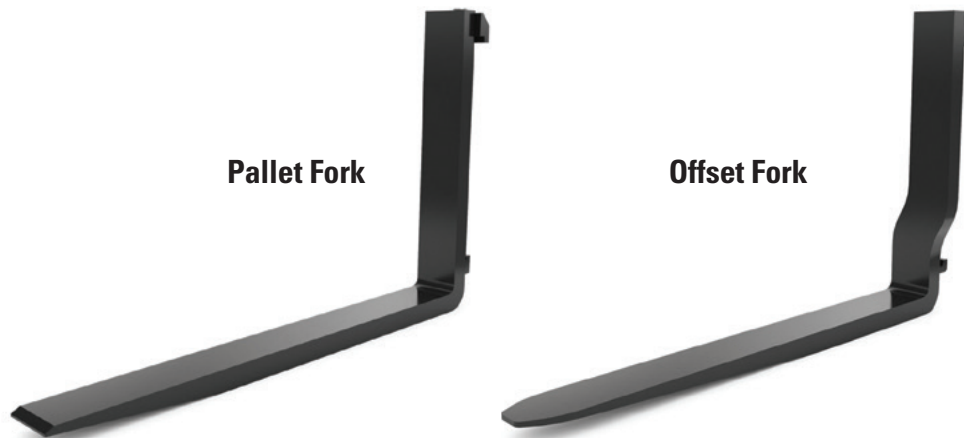

PALLET FORKS

Part Number	Weight kg (lb)	Tine Length mm (in)	Overall Length mm (in)	Width mm (in)	Thickness mm (in)	Height mm (in)	Class
6W-8933*	87 (191)	1050 (41)	1140 (45)	130 (5)	50 (2)	800 (32)	3
195-6937*	90 (198)	1070 (42)	1160 (46)	122 (4.8)	50 (2)	793 (31)	3
6W-8900	93 (206)	1200 (47)	1290 (51)	130 (5)	50 (2)	600 (24)	3
195-6938*	128 (283)	1370 (54)	1475 (58)	122 (5)	65 (2.6)	793 (31)	3
6W-9739*	101 (223)	1350 (53)	1440 (57)	130 (5)	50 (2)	800 (32)	3
195-6935*	98 (216)	1220 (48)	1310 (52)	122 (4.8)	50 (2)	793 (32)	3
553-3872*#	84 (185)	1200 (47)	1291 (51)	125 (4.9)	50 (2)	800 (32)	3
553-3873*#	95 (209)	1350 (53)	1441 (57)	125 (4.9)	50 (2)	750 (30)	3

*Order two forks for a complete set.

#For use with 532-8222 carriage only.

OFFSET FORKS

Part Number	Weight kg (lb)	Tine Length mm (in)	Overall Length mm (in)	Width mm (in)	Thickness mm (in)	Height mm (in)	Class
241-0921*	94 (207)	1220 (48)	1310 (52)	125 (4.9)	50 (2)	800 (32)	3
241-0922*	94 (207)	1220 (48)	1310 (52)	125 (4.9)	50 (2)	800 (32)	3

*Order one right and one left fork for a complete set

COMPACT WHEEL LOADERS ATTACHMENTS

Material Handling Arms move pipe, concrete blocks, highway dividers and other construction materials quickly and easily with an Extendable Material Handling Arm. Length of the arm is manually adjustable to match load and reach requirements.



**Fusion
Material Handling Arm**

MATERIAL HANDLING ARM – 914K/914, 920K, 920	FUSION
Overall Height – mm (in)	829 (33)
Overall Width – mm (in)	646 (25)
Retracted Length – mm (in)	2007 (79)
Maximum Horizontal Reach – mm (in)	3941 (155)
Maximum Load Rating – kg (lb)	2095 (4619)
Weight – kg (lb)	408 (900)
Part Number	510-5071



**ISO
Material Handling Arm**

MATERIAL HANDLING ARM	ISO
Overall Height – mm (in)	1035 (41)
Overall Width – mm (in)	758 (30)
Retracted Length – mm (in)	2603 (103)
Maximum Horizontal Reach – mm (in)	4208 (166)
Maximum Load Rating – kg (lb)	2432 (5362)
Weight – kg (lb)	488 (1076)
Part Number	510-5092



**IT
Material Handling Arm**

MATERIAL HANDLING ARM	IT
Overall Height – mm (in)	827 (33)
Overall Width – mm (in)	660 (26)
Retracted Length – mm (in)	2007 (79)
Maximum Horizontal Reach – mm (in)	3941 (155)
Maximum Load Rating – kg (lb)	2095 (4619)
Weight – kg (lb)	408 (900)
Part Number	229-9714

Snow Plows are designed for snow removal applications in parking lots, driveways, airport runways and storage lots. The trip edge system protects your machine and tool from unseen obstacles by retracting when contacting objects such as manhole covers or parking features.

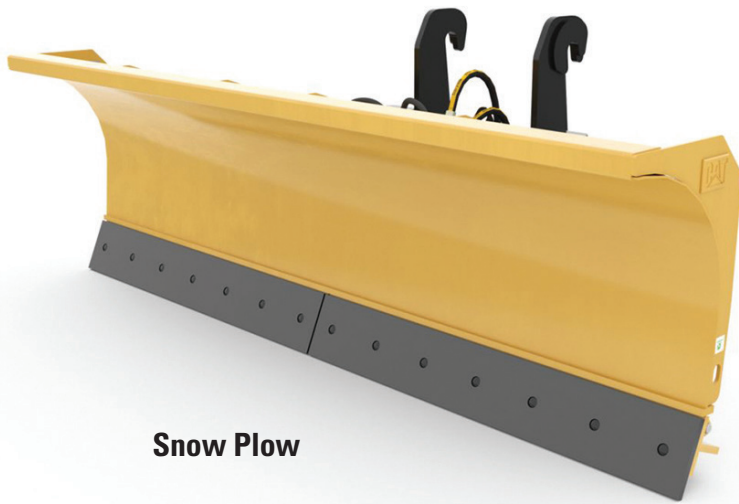

Snow Plow

SNOW PLOWS			IT
MODEL	2.7 m (9 ft)	3 m (10 ft)	3.7 m (12 ft)
Width – mm (in)	2743 (108)	3048 (120)	3658 (144)
Overall Height – mm (in)	1051 (41)	1051 (41)	1051 (41)
Blade Height – mm (in)	888 (35)	888 (35)	888 (35)
Length – mm (in)	1385 (55)	1385 (55)	1385 (55)
Weight – kg (lb)	855 (1885)	902 (1989)	989 (2180)
Trip Edge Type	Steel	Steel	Steel
Trip Edge Height – mm (in)	194 (7.6)	194 (7.6)	194 (7.6)
Hydraulic Angling (left or right of center)	+/- 35°	+/- 35°	+/- 35°
Required Hydraulics	3rd Function	3rd Function	3rd Function
Part Number	481-3671	481-3672	481-3673

SNOW PLOWS – HEAVY DUTY		IT
MODEL	3.1 m (10 ft)	
Width – mm (in)	3106 (122)	
Overall Height – mm (in)	1173 (46)	
Blade Height – mm (in)	1020 (40)	
Length – mm (in)	1073 (42)	
Weight – kg (lb)	930 (2050)	
Trip Edge	No	
Edge Type	Steel	
Hydraulic Angling (left or right of center)	+/- 35°	
Required Hydraulics	3rd Function	
Part Number	396-2548	

Straight Snow Pushes

are designed to roll and fold snow with a profiled mold board and maximize the amount of snow being pushed. Streamlined box supports ensure that snow does not cling to the tool, increasing productivity. The Cat straight snow push features a standard trip edge system which protects your machine and tool from unseen obstacles.

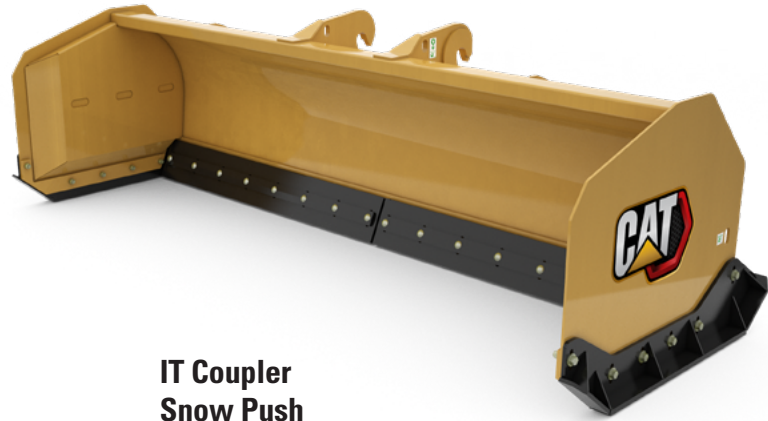

**IT Coupler
Snow Push**

STRAIGHT SNOW PUSHES				IT
MODEL	3.05 m (10 ft)	3.66 m (12 ft)	3.05 m (10 ft)	3.66 m (12 ft)
Working Width – mm (in)	3048 (120)	3658 (144)	3048 (120)	3658 (144)
Overall Width – mm (in)	3220 (127)	3829 (151)	3220 (127)	3829 (151)
Overall Height – mm (in)	975 (38)	975 (38)	975 (38)	975 (38)
Length – mm (in)	1279 (50)	1279 (50)	1279 (50)	1279 (50)
Weight – kg (lb)	818 (1803)	905 (1995)	761 (1678)	846 (1865)
Trip Edge	Yes	Yes	Yes	Yes
Trip Edge Height – mm (in)	137 (5)	137 (5)	137 (5)	137 (5)
Edge Type	Steel	Steel	Rubber	Rubber
Part Number	479-8087	479-8091	508-8290	508-8295
Cutting Edge	492-2966	482-7664	499-3626	499-3627

Straight Snow Pushes with bucket receivers mount without having to remove the machine bucket. Ideal for machines not equipped with a quick coupler option, the bucket receiver snow push is secured by sliding the cutting edge of the bucket into the receiver arms, then fastening chains around the bucket.



Straight Snow Push with Bucket Receiver

BUCKET RECEIVER SNOW PUSHES				
MODEL	3.05 m (10 ft)	3.66 m (12 ft)	3.05 m (10 ft)	3.66 m (12 ft)
Working Width – mm (in)	3048 (120)	3658 (144)	3048 (120)	3658 (144)
Overall Width – mm (in)	3220 (127)	3829 (151)	3220 (127)	3829 (151)
Overall Height – mm (in)	975 (38)	975 (38)	975 (38)	975 (38)
Length – mm (in)	1755 (69)	1755 (69)	1755 (69)	1755 (69)
Weight – kg (lb)	905 (1995)	991 (2185)	846 (1865)	932 (2055)
Trip Edge	Yes	Yes	Yes	Yes
Trip Edge Height – mm (in)	137 (5)	137 (5)	137 (5)	137 (5)
Trip Edge Type	Steel	Steel	Rubber	Rubber
Part Number	479-8088	479-8092	508-8300	508-8305
Cutting Edge	482-7618	489-3927	482-1496	489-3929



© 2023 Caterpillar. All Rights Reserved. CAT, CATERPILLAR, LET'S DO THE WORK, their respective logos, "Caterpillar Corporate Yellow", the "Power Edge" and Cat "Modern Hex" trade dress as well as corporate and product identity used herein, are trademarks of Caterpillar and may not be used without permission

AEXQ3282-02
Replaces AEXQ3282-01
(Global)

