



Cat[®] CP74B

Padfoot Drum Vibratory Soil Compactor

The Cat[®] CP74B features a padfoot drum and is ideally suited for cohesive and semi-cohesive soil applications.

Comfortable and Ergonomic Operator Station

- Features pivoting seat with integrated multifunction LCD display and control console
- Outstanding visibility to the front and rear of machine
- Low sound levels and vibration for greater operator comfort and productivity

Rear Vision Camera

- The rear vision camera enhances visibility for more complete operator control and safety

Exceptional Propel System

- Built around the exclusive Cat[®] dual pump propel system, two pumps provide separate dedicated flow to drum drive motor and rear axle motor for exceptional gradeability and traction in forward and reverse
- Electronic propel control provides more precise machine control

Virtually Maintenance Free

- Maintenance-free hitch bearings
- Extended maintenance intervals for vibratory system and hydraulic system, providing more uptime and lower maintenance costs

Enhanced Compaction Performance

- More weight at the drum and greater amplitude
- Automated speed control and vibratory system functions make it easy to ensure consistent, high quality compaction

Technologies that Enhance Quality and Productivity

- Exclusive semi-autonomous Command for Compaction technology automates compaction to offer complete process control and help promote more uniform results
- Measurement and documentation technologies help the operator determine when compaction has been completed to specification for greater productivity and uniform compaction quality
- Exclusive Machine Drive Power (MDP) measurement technology available



Cat® CP74B Padfoot Drum Vibratory Soil Compactor

Standard and Optional Equipment

Standard and optional equipment may vary. Consult your Cat dealer for details.

	Standard	Optional
OPERATOR ENVIRONMENT		
ROPS/FOPS Cab with Climate Control, External Rear View Mirrors	✓	
Cloth Adjustable Pivoting Seat with Integrated Console and LCD Display	✓	
Adjustable Tilting Steering Column with Integrated Cup Holders	✓	
Rear Vision Camera with Color Touchscreen Display	✓	
Seat Belt – 50 mm (2 in) high visibility orange	✓	
12-volt Power Outlet	✓	
Horn, Backup Alarm	✓	
Sun Visor		✓
Cab Internal Roll-down Sun Screen		✓
Seat Belt – 76 mm (3 in) high visibility orange		✓
VIBRATORY SYSTEM		
Padfoot Drum	✓	
Dual Amplitude, Single Frequency	✓	
Dual Pod-Style Eccentric Weight Housings	✓	
Auto-vibe Function	✓	
Dual Adjustable Steel Scrapers	✓	
Leveling Blade		✓
Variable Frequency		✓
TECHNOLOGY SOLUTIONS		
Measure - Machine Drive Power		✓
Map - SBAS GNSS Mapping		✓
Connect - Cloud and Machine Connectivity		✓
Command for Compaction		✓
POWERTRAIN		
Cat® C4.4 Diesel Engine		✓
Air Cleaner, Dual Element		✓
Three-Speed Throttle Switch, Eco-mode and Automatic Speed Control		✓
Dual Propel Pumps; One for Drum Drive, One for Rear Axle		✓
Fuel Filter, Water Separator, Priming Pump, Water Indicator		✓
Tilting Radiator/Hydraulic Oil Cooler		✓
Dual Braking System		✓
Two-speed Hydrostatic Transmission		✓
Transmission Guard		✓
ELECTRICAL		
24 volt Electrical System		✓
100 ampere Alternator		✓
750 Cold-cranking Amps Battery Capacity		✓
OTHER		
Product Link™		✓
Sight Gauges for Hydraulic Oil Level and Radiator Coolant Level		✓
S-O-S SM Sampling Valves: Engine Oil, Hydraulic Oil and Coolant		✓
Machine tie downs - front and rear (meet ISO 15818)		✓
Recording Module		✓
Factory Filled Bio Hydraulic Oil		✓
Fast Fill Fuel Tank		✓
Upgraded Halogen Light Package		✓
Upgraded LED light package		✓
Amber Rotating Beacon		✓
Fuel Fill Access Door		✓

Cat® CP74B Padfoot Drum Vibratory Soil Compactor

Vibratory Soil Compactor Selection Guide

16 - 20 T

Assumes density specification is 95% of Standard Proctor and can vary substantially due to different soil conditions.

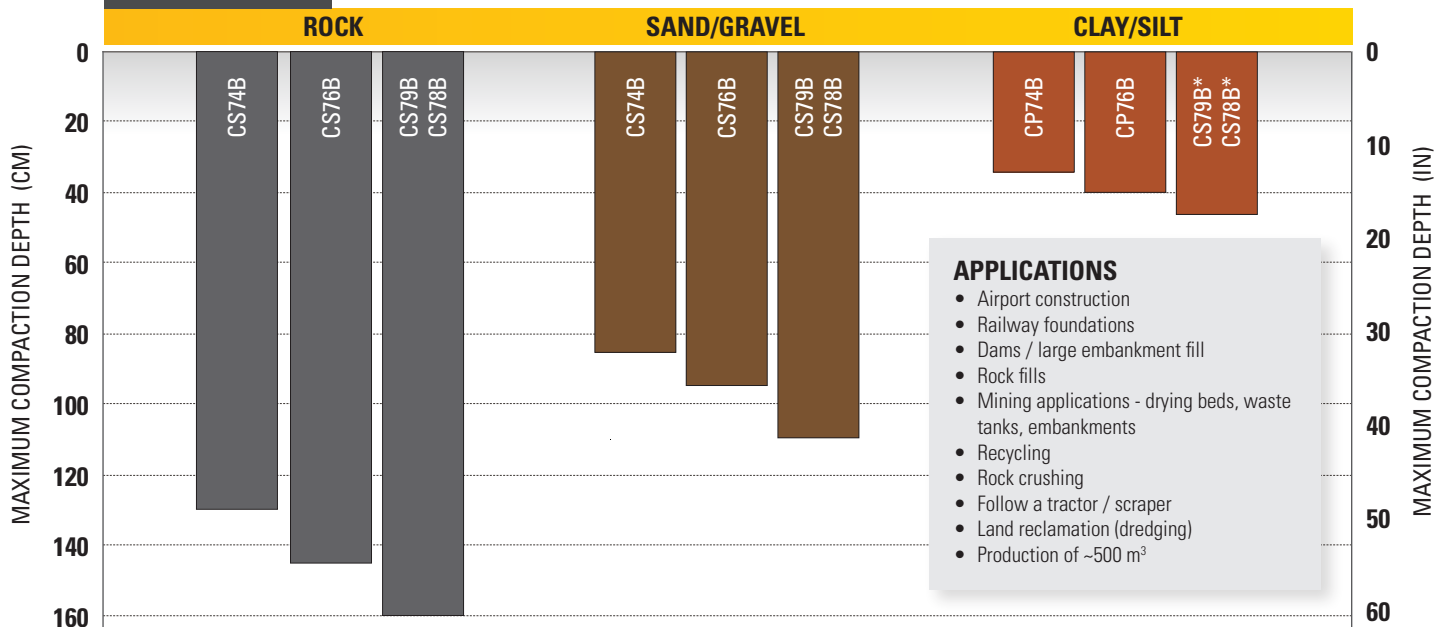

APPLICATIONS

- Airport construction
- Railway foundations
- Dams / large embankment fill
- Rock fills
- Mining applications - drying beds, waste tanks, embankments
- Recycling
- Rock crushing
- Follow a tractor / scraper
- Land reclamation (dredging)
- Production of ~500 m³

Rock

Smooth drum, high amplitude moving to low amplitude when approaching compaction, 4-8 passes

Size: Less than 50 mm (2 in) diameter

Sand/Gravel

Smooth drum, high amplitude moving to low amplitude when approaching compaction, 4-6 passes

Clay/Silt

Padfoot and smooth drum application (for smoothing), 4-10 passes. Compaction in cohesive soils strongly depends on moisture content.

* Smooth drum model equipped with padfoot shell kit

Cat® CP74B Padfoot Drum Vibratory Soil Compactor

Technical Specifications

Engine - Powertrain

Engine Model	Cat C4.4	
Emissions	EU Stage V	
Gross Power ISO 14396	129.4 kW	173.5 hp
Gross Power SAE J1995	130.4 kW	174.9 hp
Net Power ISO 9249*	108.7 kW	145.8 hp
Net Power SAE J1349*	108.2 kW	145.1 hp
Displacement	4.4 L	268.5 in ³
Stroke	127 mm	5 in
Bore	105 mm	4.1 in
Max. Travel Speed (Forward or Reverse)	11.4 km/h	7 mph
Theoretical Gradeability, no vibration**	59%	

Vibratory System Specifications

Frequency		
Standard	28 Hz	1680 vpm
During Eco-mode Operation	25.5 Hz	1527 vpm
Optional Variable Frequency	23.3-28 Hz	1400-1680 vpm
Nominal Amplitude @ 30.5 Hz (1830 vpm)		
High	2.1 mm	0.083 in
Low	0.98 mm	0.039 in
Centrifugal Force @ 30.5 Hz (1830 vpm)		
Maximum	335 kN	75,234 lb
Minimum	166 kN	37,300 lb
VM Class at High Amplitude	VM5	

Weights

Operating Weight w/ ROPS/FOPS cab***	16 355 kg	36,048 lb
w/ Leveling Blade	17 015 kg	37,503 lb
Weight at Drum w/ ROPS/FOPS cab	10 725 kg	23,633 lb
w/ Leveling Blade	11 695 kg	25,771 lb

Service Refill Capacities

Fuel Tank, total capacity	332 L	88 gal
Diesel Exhaust Fuel refill capacity	19 L	5 gal
Cooling System	28.2 L	7.5 gal
Engine Oil w/ Filter	11.6 L	3.1 gal
Eccentric Weight Housings (combined)	26 L	6.9 gal
Axle and Final Drives	18 L	4.8 gal
Hydraulic Tank (service refill)	50 L	13.2 gal

* Net power advertised is the power available at the engine flywheel when equipped with a fan at maximum speed, air cleaner, clean emissions module, and alternator.

** Actual gradeability may vary based on site conditions and machine configuration. Refer to the Operation and Maintenance Manual for more information.

*** Standard operating weight considers full fuel tank, 75 kg operator, traction tires, oval pad drum, and cab with A/C.

Cat® CP74B Padfoot Drum Vibratory Soil Compactor

Technical Specifications

Dimensions

1	Overall Length	6.05 m	19.9 ft
2	Overall Length w/ optional Leveling Blade	6.55 m	21.5 ft
3	Overall Width	2.33 m	7.64 ft
4	Overall Width w/ optional Leveling Blade	2.50 m	8.25 ft
5	Drum Width	2134 mm	84 in
6	Drum Shell Thickness	40 mm	1.6 in
7	Drum Diameter	1550 mm	61.0 in
8	Overall Height	3.11 m	10.2 ft
9	Wheelbase	2.9 m	9.5 ft
10	Ground Clearance	445 mm	17.5 in
11	Curb Clearance	497 mm	19.6 in
12	Optional Leveling Blade Height	688 mm	27.1 in
	Inside Turning Radius	3.68 m	12.07 ft
	Hitch Articulation Angle	34°	
	Hitch Oscillation Angle	15°	

Padfoot Specifications

Number of Pads	140	
Pad Height, oval pads	127 mm	5 in
Pad Face Area, oval pads	74.4 cm ²	11.5 in ²
Pad Height, optional square pads	100 mm	3.9 in
Pad Face Area, optional square pads	123 cm ²	19.1 in ²
Number of Chevrons	14	

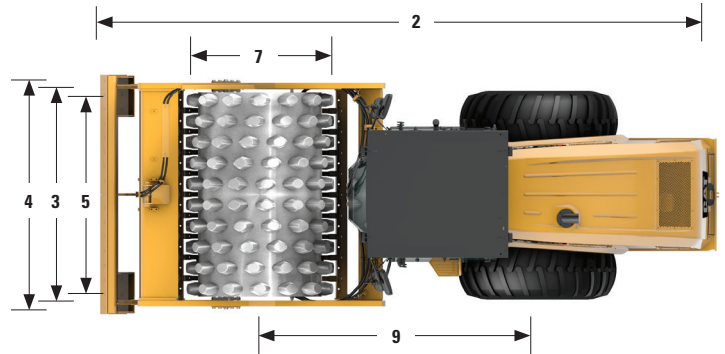
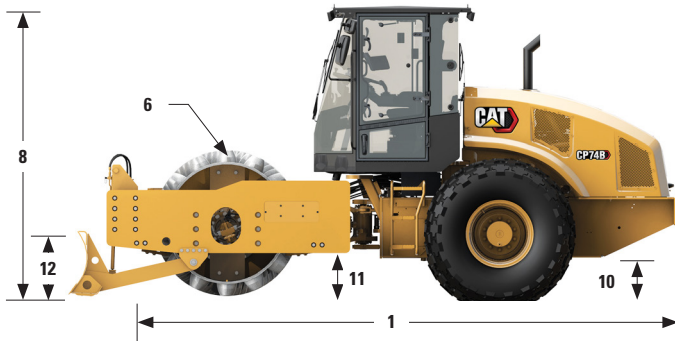

Cat® CP74B Padfoot Drum Vibratory Soil Compactor

Environmental Declaration

The following information applies to the machine at the time of final manufacture as configured for sale in the regions covered in this document. The content of this declaration is valid as of the date issued; however, content related to machine features and specifications are subject to change without notice. For additional information, please see the machine's Operation and Maintenance Manual.

For more information on sustainability in action and our progress, please visit www.caterpillar.com/en/company/sustainability.html.

ENGINE

- The Cat C4.4 engine is available in configurations that meet EU Stage V emission standards.
- Cat diesel engines are required to use ULSD (ultra-low sulfur diesel fuel with 15 ppm of sulfur or less) or ULSD blended with the following lower-carbon intensity fuels up to:
 - ✓ 20% biodiesel FAME (fatty acid methyl ester)*
 - ✓ 100% renewable diesel, HVO (hydro-treated vegetable oil) and GTL (gas-to-liquid) fuels

Refer to guidelines for successful application. Please consult your Cat dealer or "Caterpillar Machine Fluids Recommendations" (SEBU6250) for details.

**Engines with no aftertreatment devices can use higher blends, up to 100% biodiesel.*

AIR CONDITIONING SYSTEM

The air conditioning system on this machine contains the fluorinated greenhouse gas refrigerant R134a (Global Warming Potential = 1430). The system contains 0.8 kg (1.8 lb) of refrigerant, which has a CO₂ equivalent of 1.144 metric tonnes (1.261 tons).

PAINT

- Based on best available knowledge, the maximum allowable concentration, measured in parts per million (PPM), of the following heavy metals in paint are:
 - Barium < 0.01%
 - Cadmium < 0.01%
 - Chromium < 0.01%
 - Lead < 0.01%

SOUND PERFORMANCE

With cooling fan speed at maximum value:

Exterior Sound Power Level (ISO 6395:2008) – 109 dB(A)

With cooling fan speed at 70% of maximum value:

Operator Sound Pressure Level (ISO 6396:2008) – 79 dB(A)

- When properly installed and maintained, the cab offered by Caterpillar, when tested with doors and windows closed according to ANSI/SAE J1166 OCT98, meets OSHA and MSHA requirements for operator sound exposure limits in effect at time of manufacture.
- Hearing protection may be needed when operating with an open operator station and cab (when not properly maintained or doors/windows open) for extended periods or in a noisy environment.

OILS AND FLUIDS

- Caterpillar factory fills with ethylene glycol coolants. Cat Diesel Engine Antifreeze/Coolant (DEAC) and Cat Extended Life Coolant (ELC) can be recycled. Consult your Cat dealer for more information.
- Cat BIO HYDO™ Advanced is an EU Ecolabel approved biodegradable hydraulic oil.
- Additional fluids are likely to be present, please consult the Operations and Maintenance Manual or the Application and Installation guide for complete fluid recommendations and maintenance intervals.

FEATURES AND TECHNOLOGY

- The following features and technology may contribute to fuel savings and/or carbon reduction. Features may vary. Consult your Cat dealer for details.
 - Standard eco-mode limits engine RPM, lowering overall fuel consumption compared to high idle
 - Optional compaction control reduces unnecessary passes, contributing to lower overall fuel consumption
 - Extended maintenance intervals reduce fluid and filter consumption
 - Auto idle shutdown reduces unproductive hours and fuel burned
 - Hydraulic on demand fan changes speed with temperature

Cat® CP74B Padfoot Drum Vibratory Soil Compactor

For more information on Cat products, dealer services, and industry solutions visit us on the web at www.cat.com.

© 2022 Caterpillar
All rights reserved.

Materials and specifications are subject to change without notice. Featured machines in photos may include additional equipment. See your Cat dealer for available options.

CAT, CATERPILLAR, LET'S DO THE WORK, their respective logos, "Caterpillar Corporate Yellow," the "Power Edge" and Cat "Modern Hex" trade dress as well as corporate and product identity used herein, are trademarks of Caterpillar and may not be used without permission.

QEHQ2870-01 (09-2022)
Build Number 01A
Europe

