

» CAT® REMAN HEAVY-DUTY LONG BLOCK ENGINES

CAT REMAN LONG BLOCKS
SAVE YOU TIME AND MONEY
ON REPAIRS

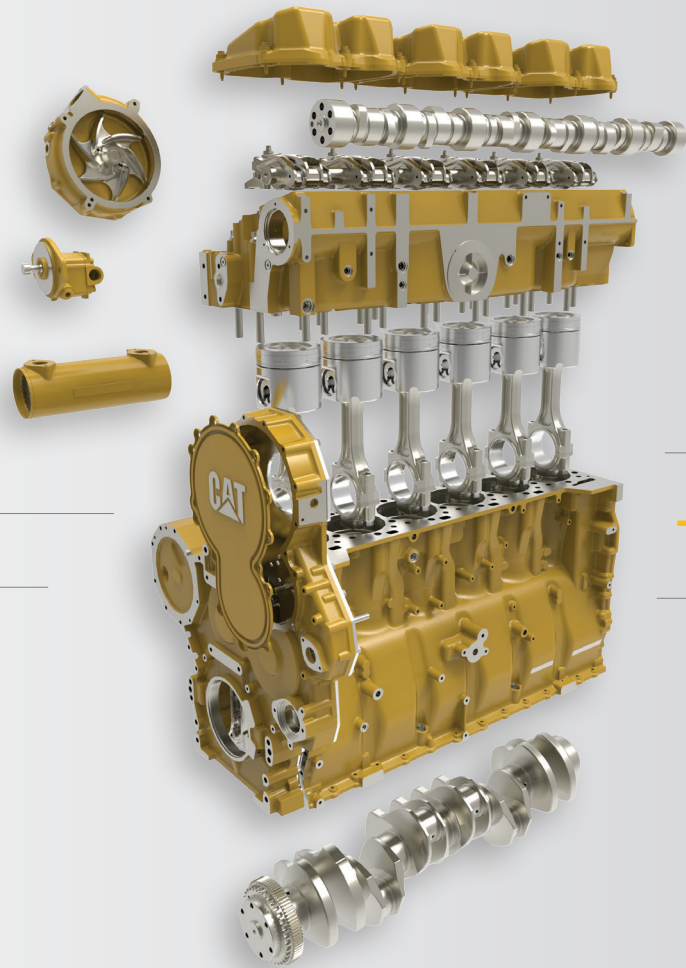

NOT ALL OVERHAULS ARE CREATED EQUAL

Getting ready for the second, third or even fourth overhaul on your Cat® heavy-duty on-highway truck engine? A standard overhaul that includes reusing the block, crank and other components may not be the best choice. As those components enter successive overhaul cycles, the chances that they'll need to be replaced or machined increase greatly — turning an in-frame rebuild into a more time-consuming and costly out-of-frame rebuild.

The solution? Cat heavy-duty long blocks. Available in two options to fit different needs, Cat Reman long blocks and Cat Reman long blocks with new content come fully assembled with all the parts you need for a quick, quality repair—parts that add up to big savings in downtime, labor and overhaul costs.



**BIG SAVINGS IN ADDED PARTS
THAT ARE ALREADY INCLUDED**



**2 REPAIR OPTIONS
TO FIT YOUR NEEDS**



**IDEAL FOR 2ND, 3RD
AND 4TH OVERHAULS**



WHICH REPAIR OPTION IS RIGHT FOR YOU?

1

CAT REMAN LONG BLOCKS: WHEN YOUR CORE IS IN GOOD CONDITION

Cat Reman long blocks are completely disassembled, thoroughly cleaned, fully inspected for damage, remanufactured to original Caterpillar specifications with the latest engineering updates and tested to ensure they deliver same-as-new performance. Choose Reman if your existing core is still in good condition — you'll get the quality you want at a more cost-effective price.

2

CAT REMAN LONG BLOCKS WITH NEW CONTENT: WHEN YOUR CORE DESERVES A RESET

Cat Reman long blocks with new content give you the chance to repower your truck without starting from scratch. They contain 100% new cylinder blocks, crankshafts and cylinder heads, giving you maximum life expectancy, enhanced overhaul potential and peace of mind. With this option you don't need to worry if your core is damaged as it gives full value for most cores, even rusted and corroded ones. It's like resetting your engine and giving the heart of your truck a jump-start.

» BOTH REPAIR OPTIONS SAVE YOU TIME AND MONEY

- No need for reusability determination
- No dealing with broken bolts
- No need to measure liner projection
- No need to outsource machining work

Plus, Cat Reman long blocks with new content eliminate the risk of reusing key components during an overhaul.

» CORE CREDIT FOR CAT REMAN LONG BLOCKS WITH NEW CONTENT

IF YOU EXPERIENCE THESE CATASTROPHIC ENGINE ISSUES, YOU QUALIFY FOR CORE CREDIT:

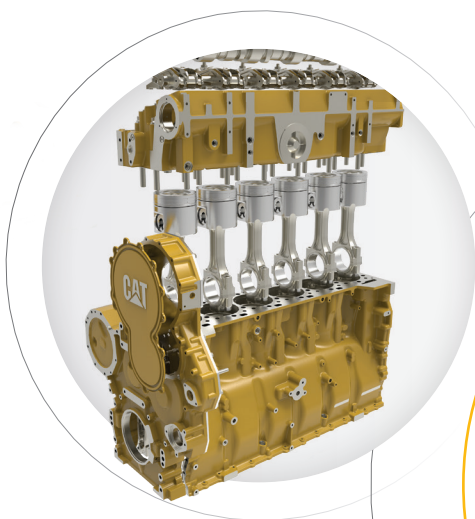

BROKEN
CRANKSHAFT



DAMAGED AND/OR
VENTILATED BLOCK



EXCESSIVE RUST
AND CORROSION



FIRE
DAMAGE

EVEN THESE
GET YOU
- CORE
CREDIT -

MORE VALUE, NO MATTER WHICH REPAIR OPTION YOU CHOOSE

CAT REMAN LONG BLOCKS AND CAT REMAN LONG BLOCKS WITH NEW CONTENT WILL GET YOU MORE WITH ADDED PARTS AND SAVE YOU MORE WITH BUILT-IN VALUE. TAKE A LOOK AT WHAT'S INCLUDED IN EVERY BLOCK.

	C9	C-10 C-12	C11 C13		C-15 3406E	C-15, 3406E with New Content	C15 ACERT	C15 ACERT with New Content
ASSEMBLED PARTS				ASSEMBLED PARTS				
Cylinder Block Group	•	•	•	Cylinder Block Group	•	100% New	•	100% New
Rod & Piston & Liner Group	•	•	•	Rod & Piston & Liner Group	•	•	•	•
Crankshaft Group	•	•	•	Crankshaft Group	•	100% New	•	100% New
Cylinder Head	•	•	•	Cylinder Head	•	100% New	•	100% New
Camshaft Group	•	•	•	Camshaft Group	•	•	•	•
Valve Mechanism Group	•	•	•	Valve Mechanism Group	•	•	•	•
Lifting Eye Group	•	•	•	Lifting Eye Group	•	•	•	•
Front Gear Group	•	•	•	Front Gear Group	•	•	•	•
Front Housing Group	•	•	•	Front Housing Group	•	•	•	•
Cover Group	•	•	•	Cover Group	•	•	•	•
Variable Valve Assembly (VVA)	N/A	N/A	•	Variable Valve Assembly (VVA)	N/A	N/A	•	•
HEUI Pump & Fuel Transfer Pump	•	N/A	N/A	Valve Mechanism Cover Group	•	•	•	•
SHIP LOOSE PARTS				SHIP LOOSE PARTS				
Oil Cooler Core Assembly	•	•	•	Oil Cooler Core Assembly	•	•	•	•
Fuel Transfer Pump Group	N/A	•	•	Pump Group – Fuel Transfer	•	•	•	•
Engine Oil Pump Group	•	•	•	Water Pump Group	•	•	•	•
Water Pump Group	N/A	•	•					
Breather Assembly	•	N/A	N/A					

SAVING YOU TIME AND MONEY

FIND YOUR CAT LONG BLOCK REPAIR SOLUTION

Engine Sales Model	Engine Serial Number	Horsepower Range	Cat Reman Long Block Part Number	Cat Reman Long Block with new content **
C-9 ACERT	9DG	275 – 400 hp	10R-9964	–
C-10	MBJ	305 – 335 hp	10R-1383	–
C-11 ACERT	KCA	305 – 370 hp	10R-6462	–
C-12	2KS	335 – 455 hp	10R-1406*	–
	MBL		10R-1384	–
C-13 ACERT	KCB	335 – 430 hp	10R-6464	–
	LEE		10R-9376	–
3406E	5EK	435 – 550 hp	0R-7961	20R-9111
	6TS			
	1LW		0R-1097	20R-9110
	2WS		10R-1512	20R-9112
C-15	6NZ	435 – 550 hp	10R-1061	20R-9108
	MBN	435 – 525 hp	10R-1372	20R-9109
C-15 ACERT	BXS	435 – 550 hp	10R-4411	20R-9105
	MXS		10R-4412	20R-9106
	NXS			
	MXS	600 – 625 hp	10R-4413	20R-9107
	NXS			
SDP	435 – 550 hp	10R-9486	–	

*When using 10R-1406 for 2KS 1-39999 use software for 2KS-40000-UP
 **Includes 100% new cylinder blocks, crankshafts and cylinder heads.

» PEACE-OF-MIND COVERAGE

Cat Reman long blocks come standard with an unlimited-mileage, 12-month parts warranty covering parts, labor and resultant damage. For even more protection, you can add Extended Service Coverage for 24, 36 or 48 months — no mileage or hour limitations.

» YOUR DEALER IS STANDING BY

The Cat dealer network stocks a broad line of new and remanufactured parts and components, supported by the Caterpillar worldwide inventory and distribution system. With more than 2,000 authorized Cat dealers in North America, your Cat dealer will have the components you need ready to install, minimizing your downtime and maintaining productivity. Contact your local dealer today.