

Cat® DE400S GC

Diesel Generator Sets



Standby: 60 Hz



Image shown may not reflect actual configuration.

Engine Model	Cat® C9.3B In-line 6, 4-cycle diesel
Bore x Stroke	115 mm x 149 mm
Displacement	9.3 L
Compression Ratio	16.5:1
Aspiration	Turbocharged Air-to-Air Aftercooled
Fuel Injection System	Common Rail
Governor	Electronic ADEM A6

Model	Standby	Emission Strategy
DE400S GC	500 kVA	Low BSFC

PACKAGE PERFORMANCE

Performance	Standby
	60 Hz
Genset power rating	500
Genset power rating with fan @ 1.0 power factor	400
Emissions	Low BSFC
Performance number	EM5662
Fuel Consumption	
100% load with fan, L/hr (gal/hr)	103.5 (27.3)
75% load with fan, L/hr (gal/hr)	77.7 (20.5)
50% load with fan, L/hr (gal/hr)	54.6 (14.4)
25% load with fan, L/hr (gal/hr)	31.9 (8.4)
Cooling System¹	
Radiator air flow restriction (system), kPa (in. water)	0.125 (0.5)
Radiator air flow, m ³ /min (cfm)	561.4 (19825.7)
Total coolant capacity, L (gal)	34 (8.98)
Inlet Air	
Combustion air inlet flow rate, m ³ /min (kg/hr)	26.0 (920)
Max. combustion air intake restriction, kPa (in. water)	6.2 (24.9)
Exhaust System	
Exhaust stack gas temperature, °C (°F)	512 (954)
Exhaust gas flow rate, m ³ /min (cfm)	52.8 (1864.6)
Exhaust system backpressure (minimum allowable) kPa (in. water)	8 (32.1)
Exhaust system backpressure (maximum allowable), kPa (in. water)	12 (48.2)
Heat Rejection	
Heat rejection to jacket water, kW (Btu/min)	156 (8857)
Heat rejection to exhaust (total) kW (Btu/min)	387 (22008)
Heat rejection to aftercooler, kW (Btu/min)	96.6 (5496)
Heat rejection to atmosphere from engine, kW (Btu/min)	27.4 (1561)
Heat Rejection	
NOx, mg/Nm ³ (g/hp-hr)	3223.3 (6.50)
CO, mg/Nm ³ (g/hp-hr)	534.4 (1.08)
HC, mg/Nm ³ (g/hp-hr)	36.8 (0.09)
PM, mg/Nm ³ (g/hp-hr)	12.0 (0.03)

DE400S GC Diesel Generator Sets Electric Power



Alternator ²	50 Hz				
	Voltages	480V	440V	220V	380V
Motor starting capability @ 30% Voltage Dip, skVA	1356	1138	1138	852	1356
Current, amps	601	656	1312	681	1203
Genset Rating ekW	400	400	400	358.8	400
Frame Size	A2955L41				
Excitation	S.E				

WEIGHTS & DIMENSIONS

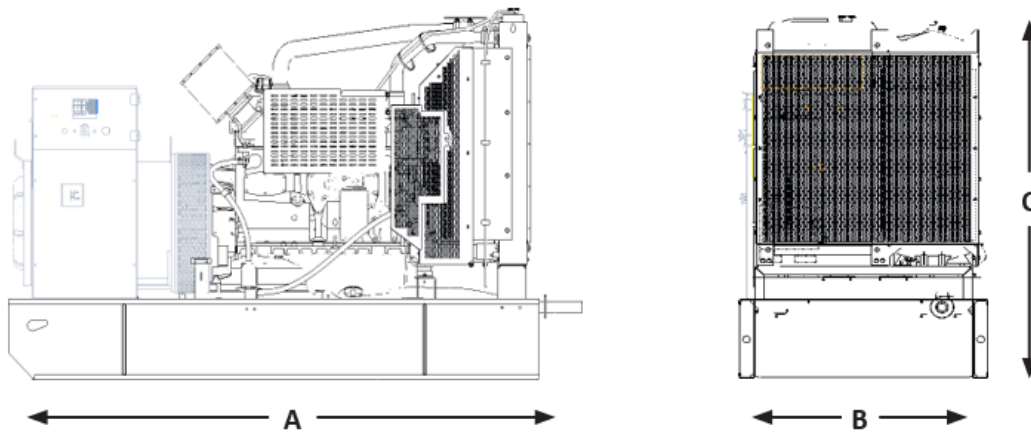

Length "A" mm (in)	Width "B" mm (in)	Height "C" mm (in)	Dry Weight kg (lb)
2670 (105.1)	1160 (45.6)	1770 (69.6)	2448 (5396.9)

Note: General configuration not to be used for installation. See general dimension drawings for detail.

APPLICABLE CODES AND STANDARDS:

AS1359, CSA C22.2 No100-04, NFPA37, NFPA70, NFPA99, NFPA110, IEC60034-1, ISO3046, ISO8528, 2006/95/EC, 2006/42/EC, 2004/108/EC.

Note: Codes may not be available in all model configurations. Please consult your local Cat Dealer representative for availability.

STANDBY: Output available with varying load for the duration of the interruption of the normal source power. Average power output is 70% of the standby power rating. Typical operation is 200 hours per year, with maximum expected usage of 500 hours per year.

RATINGS: Ratings are based on SAE J1349 standard conditions. These ratings also apply at ISO3046 standard conditions

DEFINITIONS AND CONDITIONS

¹ For ambient and altitude capabilities consult your Cat dealer. Air flow restriction (system) is added to existing restriction from factory.

² Emissions data measurement procedures are consistent with those described in EPA CFR 40 Part 89, Subpart D & E and ISO8178-1 for measuring HC, CO, PM, NOx. Data shown is based on steady state operating conditions of 77°F, 28.42 in HG and number 2 diesel fuel with 35° API and LHV of 18,390 BTU/lb. The nominal emissions data shown is subject to instrumentation, measurement, facility and engine to engine variations. Emissions data is based on 100% load and thus cannot be used to compare to EPA / EU regulations which use values based on a weighted cycle.

LET'S DO THE WORK.™

www.cat.com/electricpower

©2021 Caterpillar
All rights reserved.

Materials and specifications are subject to change without notice.

The International System of Units (SI) is used in this publication. CAT, CATERPILLAR, LET'S DO THE WORK, their respective logos, "Caterpillar Corporate Yellow" the "Power Edge" and Cat "Modern Hex" trade dress as well as corporate and product identity used herein, are trademarks of Caterpillar and may not be used without permission.