



Cat[®] 303 CR

MINI EXCAVATOR

FEATURES:

The Cat[®] 303 CR Mini Excavator delivers power and performance in a compact size to help you work in a wide range of applications.

ALL DAY COMFORT

- Choose either a canopy or a sealed and pressurized cab which can be equipped with air conditioning, adjustable wrist rests, and a suspension seat option to help keep you working comfortably all day long.

EASY TO OPERATE

- Controls are easy to use and the intuitive Next Generation LCD monitor provides easy to read machine information. An advanced touchscreen monitor can also be equipped.

STICK STEER TRAVEL MODE

- Moving around the job site is even easier with the Cat Stick Steer option. Easily switch from traditional travel controls with levers and pedals to joystick controls to move the machine and to operate the blade. The benefit of less effort and improved control is in your hands!

BIG PERFORMANCE IN A COMPACT DESIGN

- Strong lift and dig performance helps you get the job done faster. The compact radius design lets you access and work in the tightest areas. Dig-to-blade and dozer blade float features allow for easy cleanup.

SAFETY ON THE JOB SITE

- Your safety is our top priority. The Cat mini excavator is designed to help keep you safe on the job. Courtesy work lights and a fluorescent retractable seat belt with optional seat belt reminder system are just a couple of the safety features we've built into the machine.

SIMPLE SERVICE FOR LESS DOWNTIME

- Maintenance is quick and easy on the Cat mini excavator. Routine check points are easy to access at ground level through the side doors. The unique tilt up cab or canopy lets you reach additional service areas when needed.

LOWER OPERATING COSTS

- Equipped with features such as auto idle, auto engine shutdown, and efficient hydraulics with a variable displacement pump, the Cat mini excavator was designed with reducing your operating costs in mind.

UNMATCHED DEALER SUPPORT

- Your Cat dealer is here to help you reach your business goals. From providing equipment solutions to operator training to service needs and beyond, your Cat dealer is ready to help.



303 CR Mini Excavator

Specifications

Engine

Engine Model	C1.1 Turbo	
Net Power		
ISO 9249, 80/1269/EEC	17.6 kW	23.6 hp
Engine Power		
ISO 14396	18.4 kW	24.7 hp
Bore	77.0 mm	3.0 in
Stroke	81.0 mm	3.2 in
Displacement	1.1 L	69.0 in ³

- Meets U.S. EPA Tier 4 Final and EU Stage V emissions standards.
- Advertised power is tested per the specified standard in effect at the time of manufacture.
- Net power advertised is the power available at the flywheel when the engine is at the rated speed of 2,400 rpm and the engine is installed with the factory configured fan, air intake system, exhaust system and alternator with a minimum alternator load.

Weights

Minimum Operating Weight with Canopy*	3025 kg	6,670 lb
Maximum Operating Weight with Canopy**	3425 kg	7,552 lb
Minimum Operating Weight with Cab*	3140 kg	6,924 lb
Maximum Operating Weight with Cab**	3545 kg	7,817 lb
EU: CE Plate Weight with Canopy***	3080 kg	6,791 lb
EU: CE Plate Weight with Cab***	3180 kg	7,012 lb

*Minimum Weight is based on fixed rubber tracks, operator, full fuel tank, standard stick, blade, no bucket and no extra counterweight.

**Maximum Weight is based on steel tracks, operator, full fuel tank, long stick, blade, no bucket and extra counterweight.

***CE Plate Weight is based on the most common EU configuration. Includes 75 kg (165 lb) operator and full fuel tank and excludes bucket.

Weight Increase from Minimum Configuration

Cab	115 kg	254 lb
Counterweight (light)	100 kg	221 lb
Counterweight (extra)	250 kg	551 lb
Long Stick	25 kg	55 lb
Steel Tracks	125 kg	276 lb

Travel System

Travel Speed – High	4.5 km/h	2.8 mph
Travel Speed – Low	2.6 km/h	1.6 mph
Maximum Traction Force – High Speed	14.7 kN	3,305 lbf
Maximum Traction Force – Low Speed	31.4 kN	7,059 lbf
Ground Pressure – Minimum Weight	27.6 kPa	4.0 psi
Ground Pressure – Maximum Weight	32.3 kPa	4.7 psi
Gradeability (maximum)	30 degrees	

Service Refill Capacities

Cooling System	4.0 L	1.1 gal
Engine Oil	4.0 L	1.1 gal
Fuel Tank	45.0 L	11.9 gal
Hydraulic Tank	18.0 L	4.8 gal
Hydraulic System	35.0 L	9.2 gal

Hydraulic System

Load Sensing Hydraulics with Variable Displacement Piston Pump		
Pump Flow @ 2,400 rpm	100 L/min	26 gal/min
Operating Pressure – Equipment	245 bar	3,553 psi
Operating Pressure – Travel	245 bar	3,553 psi
Operating Pressure – Swing	176 bar	2,553 psi
Auxiliary Circuit – Primary		
Flow*	65 L/min	17 gal/min
Pressure*	245 bar	3,553 psi
Auxiliary Circuit – Secondary		
Flow*	25 L/min	7.0 gal/min
Pressure*	245 bar	3,553 psi
Digging Force – Stick (standard)	16.6 kN	3,732 lbf
Digging Force – Stick (long)	14.8 kN	3,327 lbf
Digging Force – Bucket	28.4 kN	6,385 lbf

*Flow and pressure are not combinable. Under load, as flow rises pressure goes down.

Swing System

Machine Swing Speed	9.0 rpm
Boom Swing – Left	75 Degrees
Boom Swing – Right	50 Degrees

Blade

Width	1550 mm	61.0 in
Height	350 mm	13.8 in

Certification – Cab and Canopy

Roll Over Protective Structure (ROPS)	ISO 12117-2:2008
Tip Over Protective Structure (TOPS)	ISO 12117:1997
Top Guard	ISO 10262:1998 (Level I)

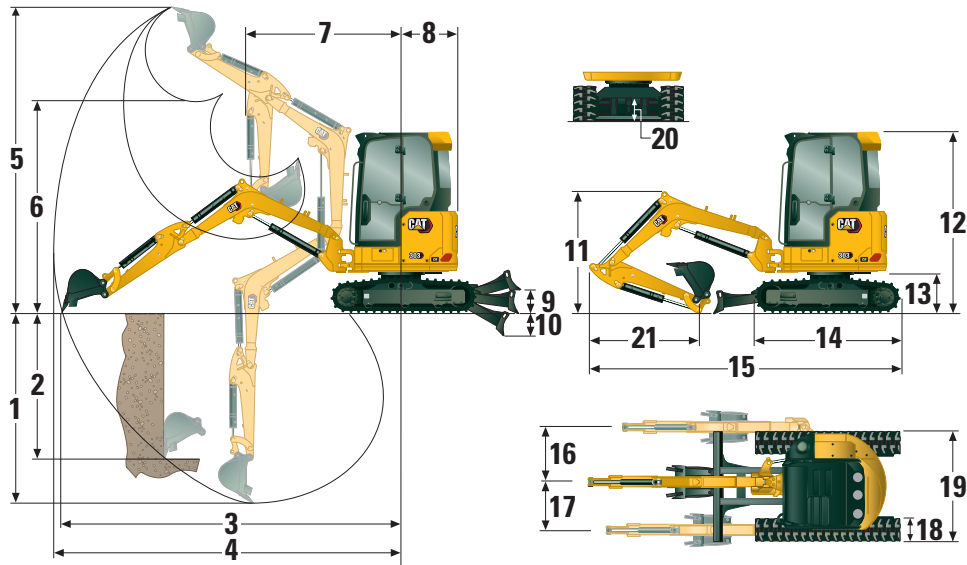

Dimensions

	Standard Stick	Long Stick
1 Dig Depth	2650 mm (104.3 in)	2950 mm (116.1 in)
2 Vertical Wall	1820 mm (71.7 in)	2070 mm (81.5 in)
3 Maximum Reach at Ground Level	4830 mm (190.2 in)	5110 mm (201.2 in)
4 Maximum Reach	4980 mm (196.1 in)	5240 mm (206.3 in)
5 Maximum Dig Height	4510 mm (177.6 in)	4650 mm (183.1 in)
6 Maximum Dump Clearance	3170 mm (124.8 in)	3310 mm (130.3 in)
7 Boom in Reach	1750 mm (68.9 in)	1910 mm (75.2 in)
8 Tail Swing		
without Counterweight	775 mm (30.5 in)	775 mm (30.5 in)
with Counterweight (light)	845 mm (33.3 in)	845 mm (33.3 in)
with Counterweight (extra)	890 mm (35.0 in)	890 mm (35.0 in)
9 Maximum Blade Height	385 mm (15.2 in)	385 mm (15.2 in)
10 Maximum Blade Depth	535 mm (21.1 in)	535 mm (21.1 in)
11 Boom Height in Shipping Position	1600 mm (63.0 in)	1920 mm (75.6 in)
12 Overall Shipping Height	2480 mm (97.6 in)	2480 mm (97.6 in)
13 Swing Bearing Height	570 mm (22.4 in)	570 mm (22.4 in)
14 Overall Undercarriage Length	2070 mm (81.5 in)	2070 mm (81.5 in)
15 Overall Shipping Length†	4510 mm (177.6 in)	4560 mm (179.5 in)
16 Boom Swing Right	870 mm (34.3 in)	870 mm (34.3 in)
17 Boom Swing Left	640 mm (25.2 in)	640 mm (25.2 in)
18 Track Belt/Shoe Width	300 mm (11.8 in)	300 mm (11.8 in)
19 Track Width	1550 mm (61.0 in)	1550 mm (61.0 in)
20 Ground Clearance	310 mm (12.2 in)	310 mm (12.2 in)
21 Stick Length	1260 mm (49.6 in)	1560 mm (61.4 in)

†Overall Shipping Length depends on blade position during shipment.

303 CR Mini Excavator

Cab

Lift Capacities – Minimum Configuration			Lift Point Radius – 2 m (6.6 ft)			Lift Point Radius – 3 m (9.8 ft)			Lift Point Radius (Maximum)			
			Over Front			Over Side	Over Front			Over Side	m (ft)	
			Blade Down	Blade Up	Blade Down		Blade Up					
3 m (9.8 ft)	Standard Stick	kg (lb)				*792 (*1,746)	630 (1,389)	548 (1,208)	*848 (*1,870)	441 (972)	385 (849)	3.67 (12.0)
	Long Stick	kg (lb)							*741 (*1,634)	376 (829)	327 (721)	3.99 (13.1)
2 m (6.6 ft)	Standard Stick	kg (lb)				*998 (*2,200)	601 (1,325)	520 (1,146)	*864 (*1,905)	349 (769)	303 (668)	4.16 (13.6)
	Long Stick	kg (lb)				*839 (*1,850)	604 (1,332)	522 (1,151)	*767 (*1,691)	304 (670)	263 (580)	4.43 (14.5)
1 m (3.3 ft)	Standard Stick	kg (lb)				*1352 (*2,981)	553 (1,219)	475 (1,047)	*903 (*1,991)	321 (708)	278 (613)	4.29 (14.1)
	Long Stick	kg (lb)				*1227 (*2,705)	549 (1,210)	470 (1,036)	*808 (*1,781)	281 (619)	242 (534)	4.55 (14.9)
0 m (0 ft)	Standard Stick	kg (lb)	*1280 (*2,822)	1003 (2,211)	823 (1,814)	*1522 (*3,355)	525 (1,157)	448 (988)	*955 (*2,105)	335 (739)	289 (637)	4.11 (13.5)
	Long Stick	kg (lb)	*1277 (*2,815)	974 (2,147)	795 (1,753)	*1480 (*3,263)	511 (1,127)	433 (955)	*862 (*1,900)	290 (639)	249 (546)	4.39 (14.4)

Minimum Weight includes cab, rubber tracks, no extra counterweight, operator, full fuel tank and blade.

Lift Capacities – Maximum Configuration			Lift Point Radius – 2 m (6.6 ft)			Lift Point Radius – 3 m (9.8 ft)			Lift Point Radius (Maximum)			
			Over Front			Over Side	Over Front			Over Side	m (ft)	
			Blade Down	Blade Up	Blade Down		Blade Up					
3 m (9.8 ft)	Standard Stick	kg (lb)				*792 (*1,746)	*792 (*1,746)	647 (1,426)	*848 (*1,870)	573 (1,263)	464 (1,023)	3.67 (12.0)
	Long Stick	kg (lb)							*741 (*1,634)	495 (1,091)	399 (880)	3.99 (13.1)
2 m (6.6 ft)	Standard Stick	kg (lb)				*998 (*2,200)	773 (1,704)	620 (1,367)	*864 (*1,905)	461 (1,016)	372 (820)	4.16 (13.6)
	Long Stick	kg (lb)				*839 (*1,850)	776 (1,711)	622 (1,371)	*767 (*1,691)	408 (899)	328 (723)	4.43 (14.5)
1 m (3.3 ft)	Standard Stick	kg (lb)				*1352 (*2,981)	725 (1,598)	576 (1,270)	*903 (*1,991)	429 (946)	345 (761)	4.29 (14.1)
	Long Stick	kg (lb)				*1227 (*2,705)	721 (1,590)	571 (1,259)	*808 (*1,781)	381 (840)	304 (670)	4.55 (14.9)
0 m (0 ft)	Standard Stick	kg (lb)	*1280 (*2,822)	*1280 (*2,822)	990 (2,183)	*1522 (*3,355)	697 (1,537)	549 (1,210)	*955 (*2,105)	449 (990)	360 (794)	4.11 (13.5)
	Long Stick	kg (lb)	*1277 (*2,815)	*1277 (*2,815)	962 (2,121)	*1480 (*3,263)	683 (1,506)	535 (1,179)	*862 (*1,900)	395 (871)	314 (692)	4.39 (14.4)

Maximum Weight includes cab, steel tracks, extra counterweight, operator, full fuel tank and blade.

Canopy

Lift Capacities – Minimum Configuration			Lift Point Radius – 2 m (6.6 ft)			Lift Point Radius – 3 m (9.8 ft)			Lift Point Radius (Maximum)			
			Over Front			Over Side	Over Front			Over Side	m (ft)	
			Blade Down	Blade Up	Blade Down		Blade Up					
3 m (9.8 ft)	Standard Stick	kg (lb)				*792 (*1,746)	603 (1,329)	526 (1,160)	*848 (*1,870)	420 (926)	368 (811)	3.67 (12.0)
	Long Stick	kg (lb)							*741 (*1,634)	357 (787)	312 (688)	3.99 (13.1)
2 m (6.6 ft)	Standard Stick	kg (lb)				*998 (*2,200)	574 (1,265)	498 (1,098)	*864 (*1,905)	331 (730)	289 (637)	4.16 (13.6)
	Long Stick	kg (lb)				*839 (*1,850)	576 (1,270)	500 (1,102)	*767 (*1,691)	288 (635)	250 (551)	4.43 (14.5)
1 m (3.3 ft)	Standard Stick	kg (lb)				*1352 (*2,981)	526 (1,160)	453 (999)	*903 (*1,991)	304 (670)	264 (582)	4.29 (14.1)
	Long Stick	kg (lb)				*1227 (*2,705)	522 (1,151)	448 (988)	*808 (*1,781)	264 (582)	228 (503)	4.55 (14.9)
0 m (0 ft)	Standard Stick	kg (lb)	*1280 (*2,822)	952 (2,099)	784 (1,728)	*1522 (*3,355)	498 (1,098)	426 (939)	*955 (*2,105)	317 (699)	275 (606)	4.11 (13.5)
	Long Stick	kg (lb)	*1277 (*2,815)	923 (2,035)	756 (1,667)	*1480 (*3,263)	483 (1,065)	411 (906)	*862 (*1,900)	273 (602)	235 (518)	4.39 (14.4)

Minimum Weight includes canopy, rubber tracks, no extra counterweight, operator, full fuel tank and blade.

Lift Capacities – Maximum Configuration			Lift Point Radius – 2 m (6.6 ft)			Lift Point Radius – 3 m (9.8 ft)			Lift Point Radius (Maximum)			
			Over Front			Over Side	Over Front			Over Side	m (ft)	
			Blade Down	Blade Up	Blade Down		Blade Up					
3 m (9.8 ft)	Standard Stick	kg (lb)				*792 (*1,746)	774 (1,706)	627 (1,382)	*848 (*1,870)	552 (1,217)	449 (990)	3.67 (12.0)
	Long Stick	kg (lb)							*741 (*1,634)	476 (1,049)	385 (849)	3.99 (13.1)
2 m (6.6 ft)	Standard Stick	kg (lb)				*998 (*2,200)	746 (1,645)	600 (1,323)	*864 (*1,905)	443 (977)	359 (791)	4.16 (13.6)
	Long Stick	kg (lb)				*839 (*1,850)	748 (1,649)	601 (1,325)	*767 (*1,691)	391 (862)	315 (694)	4.43 (14.5)
1 m (3.3 ft)	Standard Stick	kg (lb)				*1352 (*2,981)	698 (1,539)	555 (1,224)	*903 (*1,991)	412 (908)	332 (732)	4.29 (14.1)
	Long Stick	kg (lb)				*1227 (*2,705)	694 (1,530)	550 (1,213)	*808 (*1,781)	365 (805)	292 (644)	4.55 (14.9)
0 m (0 ft)	Standard Stick	kg (lb)	*1280 (*2,822)	1269 (2,798)	954 (2,103)	*1522 (*3,355)	670 (1,477)	529 (1,166)	*955 (*2,105)	431 (950)	346 (763)	4.11 (13.5)
	Long Stick	kg (lb)	*1277 (*2,815)	1240 (2,734)	927 (2,044)	*1480 (*3,263)	655 (1,444)	514 (1,133)	*862 (*1,900)	378 (833)	301 (664)	4.39 (14.4)

Maximum Weight includes canopy, steel tracks, extra counterweight, operator, full fuel tank and blade.

*The above loads are in compliance with hydraulic excavator lift capacity rating standard ISO 10567:2007 and they do not exceed 87% of hydraulic lifting capacity or 75% of tipping capacity. The excavator bucket weight is not included on this chart. Lifting capacities are for standard stick.

Standard and Optional Equipment

Standard and optional equipment may vary. Consult your Cat dealer for details.

	Standard	Optional		Standard	Optional
ENGINE			OPERATOR ENVIRONMENT (continued)		
Cat® C1.1 Turbo Engine (U.S. EPA Tier 4 Final/ EU Stage V)	✓		Fabric Suspension Seat (Cab only)	✓	
Automatic Engine Idle	✓		Vinyl Suspension Seat (Canopy only)	✓	
Automatic Engine Shutdown	✓		Vinyl Non-Suspension Seat (Canopy only) (not available in all regions)		✓
Automatic Two Speed Travel	✓		Hydraulic Lockout – All Controls	✓	
Fuel Water Separator	✓		Retractable High Visibility Seat Belt (75 mm/3 in)	✓	
Power on Demand (not available in all regions)	✓		Seat Belt Reminder System		✓
Variable Displacement Piston Pump	✓		Coat Hook	✓	
Load Sensing/Flow Sharing Hydraulics	✓		Cup Holder	✓	
HYDRAULICS			Storage Pocket	✓	
Smart Tech Electronic Pump	✓		Skylight	✓	
Accumulator	✓		Mounting Bosses for Front	✓	
Automatic Swing Brake	✓		Signaling/Warning Horn	✓	
Auxiliary Hydraulic Lines	✓		Interior Light (Cab only)	✓	
One and Two Way Auxiliary Flow	✓		Boom Light, Halogen (not available in all regions)	✓	
Continuous Auxiliary Flow	✓		LED Front Lights		✓
Auxiliary Line Quick Disconnects	✓		LED Front and Rear Lights		✓
OPERATOR ENVIRONMENT			LED Boom Light		✓
Tilt-up Canopy or Tilt-Up Cab	✓		Utility Space for Mobile Phone	✓	
Cab with Air Conditioning		✓	Mirrors Left and Right		✓
Cab with Heater		✓	Radio – Bluetooth®, Auxiliary, Microphone, USB (charging only) (Cab only)		✓
ROPS – ISO 12117-2:2008	✓		Next Generation Color LCD Monitor (IP66)	✓	
TOPS – ISO 12117:1997	✓		– Fuel Level and Coolant Temperature Gauges	✓	
Stick Steer Mode	✓		– Maintenance and Machine Monitoring	✓	
Travel Cruise Control	✓		– Performance and Machine Adjustments	✓	
Control Pattern Changer (optional in some regions)	✓		– Numeric Security Code	✓	
Adjustable Wrist Rests	✓		– Multiple Languages	✓	
Washable Floor Mat	✓		– Hour Meter with Wake Up Switch	✓	
Travel Pedals and Hand Levers	✓		– Jog Dial (cab only)	✓	
No Travel Pedals and Hand Levers (optional in some regions)		✓	Next Generation Advanced Monitor		✓
Machine Security	✓		– Touch Screen		✓
Standard Key with Pass Code	✓		– Site Reference System		✓
Push to Start with Key Fob/Pass Code		✓	– High Definition Camera Capable (IP68 and IP69K)		✓
			– Numeric Security Code		✓

(continued on next page)

303 CR Mini Excavator

Standard and Optional Equipment *(continued)*

Standard and optional equipment may vary. Consult your Cat dealer for details.

	Standard	Optional		Standard	Optional
UNDERCARRIAGE			ELECTRICAL		
Rubber Belt (300 mm/11.8 in wide)	✓		12 Volt Battery	✓	
Steel Track (300 mm/11.8 in wide)		✓	Software (machine and monitor)	✓	
Dozer Blade	✓		Maintenance Free Battery	✓	
Dozer Blade Float	✓		Battery Disconnect	✓	
Tie Downs on Track Frame	✓		Signaling/Warning Horn	✓	
BOOM, STICK AND LINKAGES			12 Volt Power Socket	✓	
One Piece Boom (2200 mm/86.6 in)	✓		Product Link™ PL243 (regulations apply)		✓
Standard Stick (1260 mm/49.6 in)	✓		Product Link PLE643 (regulations apply)		✓
Long Stick (1560 mm/61.4 in)		✓	Travel Alarm (standard in some regions)		✓
Front Shovel Capable	✓		GUARDING		
Pin-On	✓		Top Guard ISO 10262:1998 Level I	✓	
Dual Lock Manual Coupler		✓	Polycarbonate Half Height Front Guard (Canopy only)		✓
Hydraulic Coupler		✓	Polycarbonate Front Guard (ISO 10262:1998 Level I and EN356 P5A)		✓
Thumb Ready (not available in all regions)	✓		OTHER		
Certified Lifting Eye (optional in some regions)	✓		Bio Oil Capable		✓
Attachments including Couplers, Thumbs, Buckets, Augers and Hammers		✓	Eco Drain		✓
2nd Auxiliary Hydraulic Lines		✓	Water Jacket Heater		✓
Bucket Divert Lines		✓	Extra Counterweight (250 kg/551 lb)		✓
Boom Lowering Check Valve		✓			
Stick Lowering Check Valve		✓			
Hydraulic Quick Coupler Lines (not available in all regions)		✓			

The following information applies to the machine at the time of final manufacture as configured for sale in the regions covered in this document. The content of this declaration is valid as of the date issued; however, content related to machine features and specifications are subject to change without notice. For additional information, please see the machine's Operation and Maintenance Manual.

For more information on sustainability in action and our progress, please visit <https://www.caterpillar.com/en/company/sustainability>.

Engine

- The Cat® C1.1 engine meets U.S. EPA Tier 4 Final and EU Stage V emission standards.
- Cat diesel engines are required to use ULSD (ultra-low sulfur diesel fuel with 15 ppm of sulfur or less) or ULSD blended with the following lower-carbon intensity fuels** up to:
 - ✓ 20% biodiesel FAME (fatty acid methyl ester)*
 - ✓ 100% renewable diesel, HVO (hydrotreated vegetable oil) and GTL (gas-to-liquid) fuels

Refer to guidelines for successful application. Please consult your Cat dealer or "Caterpillar Machine Fluids Recommendations" (SEBU6250) for details.

**Engines with no aftertreatment devices can use higher blends, up to 100% biodiesel (for use of blends higher than 20% biodiesel, consult your Cat dealer).*

***Tailpipe greenhouse gas emissions from lower-carbon intensity fuels are essentially the same as traditional fuels.*

Air Conditioning System

- The air conditioning system on this machine contains the fluorinated greenhouse gas refrigerant R134a (Global Warming Potential = 1430). The system contains 1.0 kg (2.20 lb) of refrigerant which has a CO₂ equivalent of 1.430 metric tonnes (1.58 tons).

Paint

- Based on best available knowledge, the maximum allowable concentration, measured in parts per million (PPM), of the following heavy metals in paint are:
 - Barium < 0.01%
 - Cadmium < 0.01%
 - Chromium < 0.01%
 - Lead < 0.01%

Sound Performance

Operator Sound Pressure* 72 dB(A) (ISO 6396:2008)

Exterior Sound Power Level** 99 dB(A) (ISO 6395:2008)

*The declared dynamic operator sound pressure levels per ISO 6396:2008. The measurements were conducted with the cab doors and windows closed.

- **The labeled sound power level for the CE marked configurations when measured according to the test procedure and conditions specified in 2000/14/EC.

Oils and Fluids

- Caterpillar factory fills with ethylene glycol coolants. Cat Diesel Engine Antifreeze/Coolant (DEAC) and Cat Extended Life Coolant (ELC) can be recycled. Consult your Cat dealer for more information.
- Cat Bio HYDO™ Advanced is an EU Ecolabel approved biodegradable hydraulic oil.
- Additional fluids are likely to be present, please consult the Operations and Maintenance Manual or the Application and Installation guide for complete fluid recommendations and maintenance intervals.

Features and Technology

- The following features and technology may contribute to fuel savings and/or carbon reduction. Features may vary. Consult your Cat dealer for details.
 - Advanced hydraulic systems balance power and efficiency
 - Power On Demand provides full time efficiency and power when you need it, and is transparent to the operator
 - Auto idle and auto engine shutdown
 - Extended maintenance intervals reduce fluid and filter consumption
 - Remote Flash and Remote Troubleshoot (if equipped)

Recycling

- The materials included in machines are categorized as below with approximate weight percentage. Because of variations of product configurations, the following values in the table may vary.

Material Type	
Steel	65.26%
Iron	13.07%
Rubber	8.59%
Other	3.04%
Nonferrous Metal	2.93%
Plastic	2.67%
Fluid	2.35%
Uncategorized	0.85%
Mixed-Metal and Nonmetal	0.68%
Mixed-Metal	0.54%
Mixed-Nonmetallic	0.02%
Total	100%

- A machine with higher recyclability rate will ensure more efficient usage of valuable natural resources and enhance End-of-Life value of the product. According to ISO 16714 (Earth-moving machinery – Recyclability and recoverability – Terminology and calculation method), recyclability rate is defined as percentage by mass (mass fraction in percent) of the new machine potentially able to be recycled, reused or both.

All parts in the bill of material are first evaluated by component type based on a list of components defined by the ISO 16714 and Japan CEMA (Construction Equipment Manufacturers Association) standards. Remaining parts are further evaluated for recyclability based on material type.

Because of variations of product configurations, the following values in the table may vary.

Recyclability	95%
---------------	-----

- The data provided above was based on the product configuration as provided by the individual product group.

303 CR Mini Excavator

For more complete information on Cat products, dealer services, and industry solutions, visit us on the web at www.cat.com

© 2024 Caterpillar
All rights reserved

Materials and specifications are subject to change without notice. Featured machines in photos may include additional equipment. See your Cat dealer for available options.

CAT, CATERPILLAR, LET'S DO THE WORK, their respective logos, "Caterpillar Corporate Yellow," the "Power Edge" and Cat "Modern Hex" trade dress as well as corporate and product identity used herein, are trademarks of Caterpillar and may not be used without permission.

AEHQ8350-02 (03-2024)
Replaces AEHQ8350-01
Build Number: 07A
(Global excluding
China and Japan)

